

Product availability: Stock - Normally stocked in distribution facility



Main

Range of product	Modicon M241
Product or component type	Logic controller
[Us] rated supply voltage	100...240 V AC
Discrete input number	14, discrete input 8 fast input IEC 61131-2 Type 1
Discrete output type	Transistor Relay
Discrete output number	6 relay 4 transistor 4 fast output
Discrete output voltage	5...125 V DC relay output 5...250 V AC relay output 24 V DC transistor output
Discrete output current	2 A relay output Q4...Q9) 0.1 A fast output (PTO mode) TR0...TR3) 0.5 A transistor output TR0...TR3)

Complementary

Discrete I/O number	24
Maximum number of I/O expansion module	7 local 14 remote
Supply voltage limits	85...264 V
Network frequency	50/60 Hz
Discrete input logic	Sink or source
Discrete input voltage	24 V
Discrete input voltage type	DC
Voltage state 1 guaranteed	>= 15 V input
Voltage state 0 guaranteed	<= 5 V input
Discrete input current	5 mA input
Input impedance	4.7 kOhm input
Response time	50 µs turn-on, I0...I13 input
Configurable filtering time	1 µs fast input
Discrete output logic	Positive logic (source)
Output voltage limits	125 V DC relay output 30 V DC transistor output 277 V AC relay output
Maximum output frequency	1 KHz transistor output 20 KHz fast output (PWM mode) 100 kHz fast output (PLS mode)
Accuracy	+/- 0.1 % 0.02...0.1 kHz fast output +/- 1 % 0.1...1 kHz fast output
Protection type	Short-circuit protection transistor output Short-circuit and overload protection with automatic reset transistor output Reverse polarity protection transistor output Without protection relay output
Reset time	10 Ms automatic reset output 12 s automatic reset fast output
Memory capacity	8 MB program 64 MB system memory RAM
Data backed up	128 MB built-in flash memory backup of user programs
Data storage equipment	<= 16 GB SD card optional)

Battery type	BR2032 lithium non-rechargeable 4 year(s)
Backup time	2 years 77 °F (25 °C)
Execution time for 1 KInstruction	0.3 Ms event and periodic task 0.7 ms other instruction
Application structure	4 cyclic master tasks 8 external event tasks 8 event tasks 3 cyclic master tasks + 1 freewheeling task
Realtime clock	With
Clock drift	<= 60 s/month 77 °F (25 °C)
Positioning functions	PTO 4 100 kHz)
Counting input number	4 fast input (HSC mode) 200 kHz 14 standard input 1 kHz
Control signal type	A/B 100 kHz fast input (HSC mode) Pulse/Direction 200 kHz fast input (HSC mode) Single phase 200 kHz fast input (HSC mode)
Integrated connection type	Non isolated serial link serial 1 RJ45 RS232/RS485 Non isolated serial link serial 2 removable screw terminal block RS485 USB port mini B USB 2.0 Ethernet RJ45 CANopen J1939 male SUB-D 9
Supply	Serial 1)serial link supply 5 V, <200 mA
Transmission rate	1.2...115.2 kbit/s (115.2 kbit/s by default) 49.21 ft (15 m) RS485 1.2...115.2 kbit/s (115.2 kbit/s by default) 9.84 ft (3 m) RS232 480 Mbit/s 9.84 ft (3 m) USB 10/100 Mbit/s Ethernet 1000 kbit/s 65.62 ft (20 m) CANopen 800 kbit/s 131.23 ft (40 m) CANopen 500 kbit/s 328.08 ft (100 m) CANopen 250 kbit/s 820.21 ft (250 m) CANopen 125 kbit/s 1640.42 ft (500 m) CANopen 50 kbit/s 3280.84 ft (1000 m) CANopen 20 kbit/s 8202.10 ft (2500 m) CANopen
Communication port protocol	Non isolated serial link Modbus master/slave
Port Ethernet	10BASE-T/100BASE-TX - 1 copper cable
Ethernet services	SNMP client/server Modbus TCP slave device Modbus TCP server Modbus TCP client IEC VAR ACCESS FTP client/server SQL client DHCP client Ethernet/IP adapter Send and receive email from the controller based on TCP/UDP library Web server (WebVisu & XWeb system) OPC UA server DNS client
Local signalling	PWR 1 LED green) RUN 1 LED green) Module error (ERR) 1 LED red) I/O error (I/O) 1 LED red) SD card access (SD) 1 LED green) BAT 1 LED red) SL1 1 LED green) SL2 1 LED green) Bus fault on TM4 (TM4) 1 LED red) I/O state 1 LED per channel green) Ethernet port activity 1 LED green) CANopen run 1 LED green) CANopen error 1 LED green)
Electrical connection	Removable screw terminal block for inputs and outputs pitch 5.08 mm) Removable screw terminal block for connecting the 24 V DC power supply pitch 5.08 mm)
Maximum cable distance between devices	Unshielded cable <164.04 ft (50 m) input Shielded cable <32.81 ft (10 m) fast input Unshielded cable <164.04 ft (50 m) output Shielded cable <9.84 ft (3 m) fast output
Insulation	Between supply and internal logic 500 V AC Non-insulated between supply and ground
Marking	CE
Sensor power supply	24 V DC 400 mA supplied by the controller

Surge withstand	2 KV power lines (AC) common mode EN/IEC 61000-4-5 2 KV relay output common mode EN/IEC 61000-4-5 1 KV shielded cable common mode EN/IEC 61000-4-5 1 KV power lines (AC) differential mode EN/IEC 61000-4-5 1 KV relay output differential mode EN/IEC 61000-4-5 1 KV input common mode EN/IEC 61000-4-5 1 kV transistor output common mode EN/IEC 61000-4-5
Web services	Web server
Maximum number of connections	16 Ethernet/IP device 8 Modbus server
CANopen feature profile	DR 303-1 DS 301 V4.02
Number of slave	63 CANopen
Mounting support	Top hat type TH35-15 rail IEC 60715 Top hat type TH35-7.5 rail IEC 60715 Plate or panel with fixing kit
Height	3.54 in (90 mm)
Depth	3.74 in (95 mm)
Width	5.91 in (150 mm)
Net weight	1.17 lb(US) (0.53 kg)

Environment

Standards	ANSI/ISA 12-12-01 CSA C22.2 No 142 CSA C22.2 No 213 EN/IEC 61131-2:2007 Marine specification (LR, ABS, DNV, GL) UL 1604 UL 508
Product certifications	CSA IACS E10 RCM CULus
Resistance to electrostatic discharge	8 KV in air EN/IEC 61000-4-2 4 kV on contact EN/IEC 61000-4-2
Resistance to electromagnetic fields	9.14 V/m (10 V/m) 80 MHz...1 GHz EN/IEC 61000-4-3 2.74 V/m (3 V/m) 1.4 GHz...2 GHz EN/IEC 61000-4-3 0.91 V/m (1 V/m) 2 GHz...3 GHz EN/IEC 61000-4-3
Resistance to fast transients	2 KV EN/IEC 61000-4-4 power lines) 2 KV EN/IEC 61000-4-4 relay output) 1 KV EN/IEC 61000-4-4 Ethernet line) 1 KV EN/IEC 61000-4-4 serial link) 1 KV EN/IEC 61000-4-4 input) 1 kV EN/IEC 61000-4-4 transistor output)
Resistance to conducted disturbances	10 V 0.15...80 MHz EN/IEC 61000-4-6 3 V 0.1...80 MHz Marine specification (LR, ABS, DNV, GL) 10 V spot frequency (2, 3, 4, 6.2, 8.2, 12.6, 16.5, 18.8, 22, 25 MHz) Marine specification (LR, ABS, DNV, GL)
Electromagnetic emission	Conducted emissions 120...69 dB μ V/m QP power lines)10...150 kHz EN/IEC 55011 Conducted emissions 63 dB μ V/m QP power lines)1.5...30 MHz EN/IEC 55011 Conducted emissions 79 dB μ V/m QP/66 dB μ V/m AV power lines)0.15...0.5 MHz EN/IEC 55011 Conducted emissions 73 dB μ V/m QP/60 dB μ V/m AV power lines)0.5...300 MHz EN/IEC 55011 Radiated emissions 40 dB μ V/m QP class A 10 m)30...230 MHz EN/IEC 55011 Conducted emissions 79...63 dB μ V/m QP power lines)150...1500 kHz EN/IEC 55011 Radiated emissions 47 dB μ V/m QP class A 10 m)230...1000 MHz EN/IEC 55011
Immunity to microbreaks	10 ms
Ambient air temperature for operation	14...122 °F (-10...50 °C) vertical installation) 14...131 °F (-10...55 °C) horizontal installation)
Ambient air temperature for storage	-13...158 °F (-25...70 °C)
Relative humidity	10...95 %, without condensation in operation) 10...95 %, without condensation in storage)
IP degree of protection	IP20 with protective cover in place
Pollution degree	2
Operating altitude	0...6561.68 ft (0...2000 m)

Storage altitude	0.00...9842.52 ft (0...3000 m)
Vibration resistance	3.5 mm 5...8.4 Hz symmetrical rail 3 gn 8.4...150 Hz symmetrical rail 3.5 mm 5...8.4 Hz panel mounting 3 gn 8.4...150 Hz panel mounting
Shock resistance	15 gn 11 ms

Ordering and shipping details

Category	22533 - M2XX PLC & ACCESSORIES
Discount Schedule	MSX
GTIN	00785901306788
Package weight(Lbs)	0.78 kg (1.71 lb(US))
Returnability	Yes
Country of origin	ID

Offer Sustainability

Sustainable offer status	Green Premium product
California proposition 65	WARNING: This product can expose you to chemicals including: Lead and lead compounds which is known to the State of California to cause Carcinogen & Reproductive harm. For more information go to www.p65warnings.ca.gov
REACH Regulation	REACH Declaration
EU RoHS Directive	Pro-active compliance (Product out of EU RoHS legal scope) EU RoHS Declaration
Mercury free	Yes
RoHS exemption information	Yes
China RoHS Regulation	China RoHS Declaration
Environmental Disclosure	Product Environmental Profile
Circularity Profile	End Of Life Information
WEEE	The product must be disposed on European Union markets following specific waste collection and never end up in rubbish bins.
PVC free	Yes

Dimensions

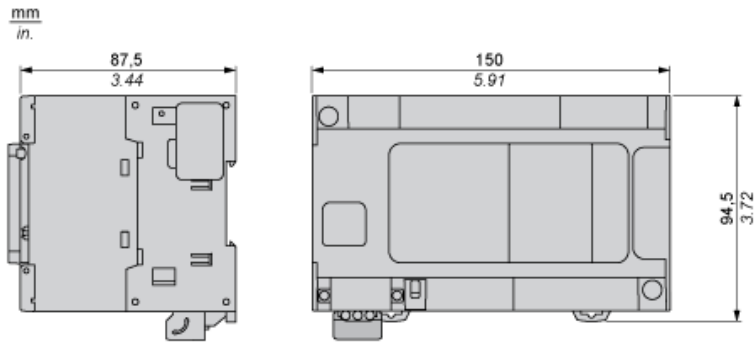

Clearance

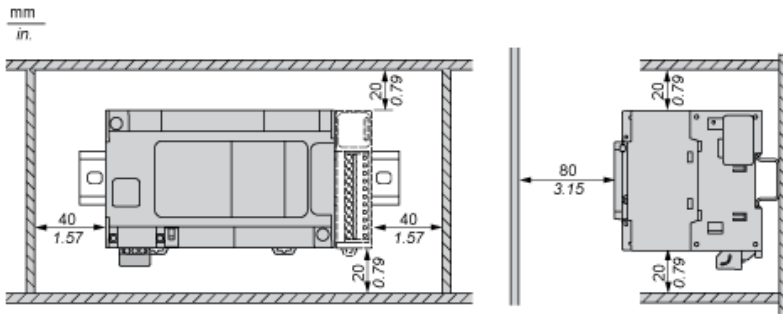

Mounting Position

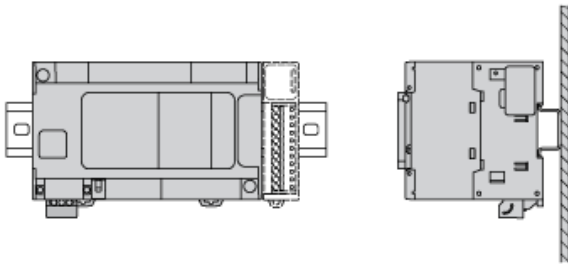

Acceptable Mounting

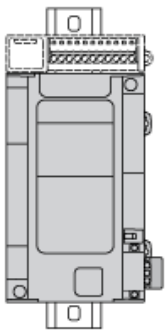

NOTE: Expansion modules must be mounted above the logic controller.

Incorrect Mounting

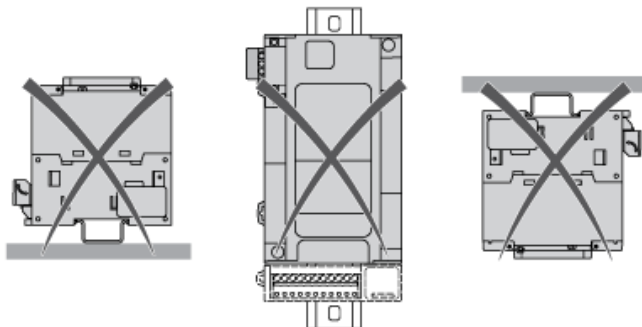

Direct Mounting On a Panel Surface

Mounting Hole Layout

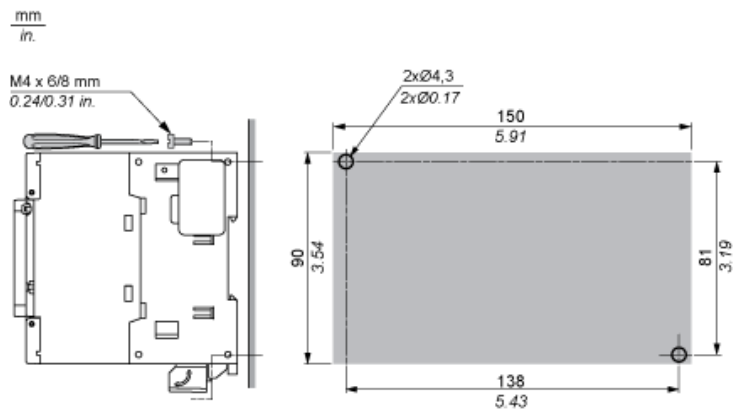

Digital Inputs

Wiring Diagram (Positive Logic)

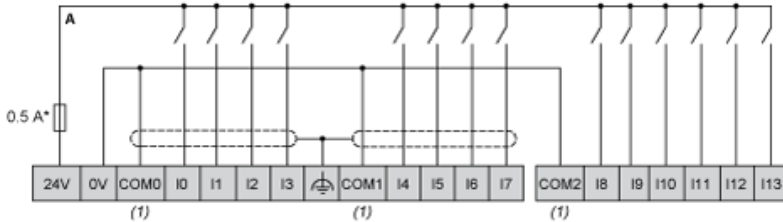

- (*) : Type T fuse
- (1) : The COM0, COM1 and COM2 terminals are not connected internally.

Wiring Diagram (Negative Logic)

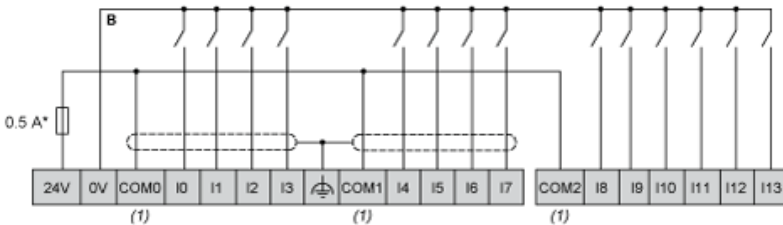

- (*) : Type T fuse
- (1) : The COM0, COM1 and COM2 terminals are not connected internally.

Fast Transistor Outputs

Wiring Diagram

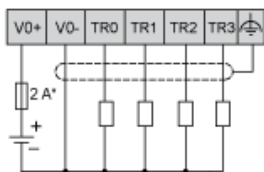

- (*) : 2 A fast-blow fuse

Relay Outputs

Wiring Diagram

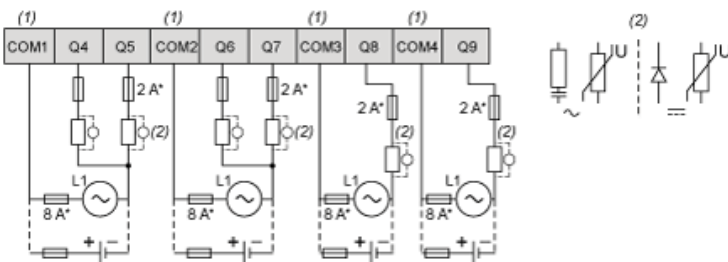

- (*) : Type T fuse
- (1) : The terminals COM1 to COM4 are not connected internally.
- (2) : To improve the life time of the contacts, and to protect from potential inductive load damage, you must connect a free wheeling diode in parallel to each inductive DC load or an RC snubber in parallel of each inductive AC load

USB Mini-B Connection

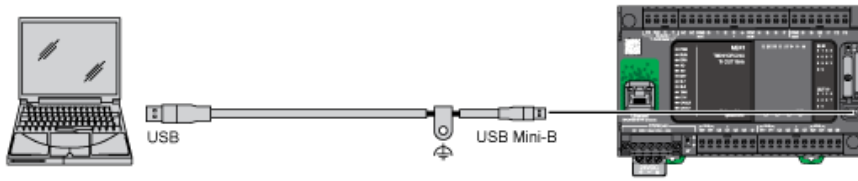

Ethernet Connection to a PC

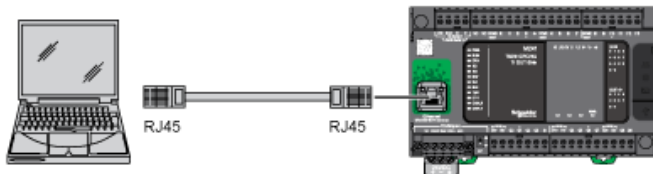

CANopen Connection

Wiring Diagram

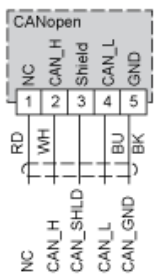

Pin	Signal	Description	Marking	Color of Cable
1	Not used	Reserved	NC	red
2	CAN_H	CAN_H bus line (dominant high)	CAN_H	white
3	CAN_SHLD	Optional CAN shield	Shield	-
4	CAN_L	CAN_L bus line (dominant low)	CAN_L	blue
5	CAN_GND	CAN Ground	GND	black