

0.9-V to 6.5-V, Nanopower Comparator

Check for Samples: [TLV3691](#)

FEATURES

- **Low Quiescent Current: 75 nA**
- **Wide Supply:**
 - +0.9 V to +6.5 V
 - ±0.45 V to ±3.25 V
- **microPackages: DFN-6 (1 mm × 1 mm), SC70-5**
- **Input Common-Mode Range Extends 100 mV Beyond Both Rails**
- **Response Time: 24 μs**
- **Low Input Offset Voltage: ±3 mV**
- **Push-Pull Output**
- **Industrial Temperature Range: –40°C to +125°C**

APPLICATIONS

- **Over- and Undervoltage Detection**
- **Window Comparators**
- **Overcurrent Detection**
- **Zero-Crossing Detection**
- **System Monitoring:**
 - Smart Phones
 - Tablets
 - Industrial Sensors
 - Portable Medical

DESCRIPTION

The TLV3691 offers a wide supply range, low quiescent current, and rail-to-rail inputs. All of these features come in industry-standard and extremely small packages, making this device an excellent choice for low-voltage and low-power applications.

Available as a single channel, the low-power, wide supply and temperature range makes this device flexible enough to handle almost any application from consumer to industrial. The TLV3691 is available in SC70-5 and 1-mm × 1-mm DFN-6 packages. This device is specified for operation across the expanded industrial temperature range of –40°C to +125°C.

RELATED PRODUCTS

FEATURES	DEVICE
40-ns, 40-μA, push-pull comparator	TLV3201
	TLV3202
4.5-ns, rail-to-rail, high-speed comparator	TLV3501
	TLV3502
Nanopower push-pull output comparator	TLV3491
	TLV3492
	TLV3494
3.9-μA, SC70-3 voltage reference	REF3312
	REF3318
	REF3320
	REF3325
	REF3330
	REF3333

Package Footprint Comparison (To Scale)

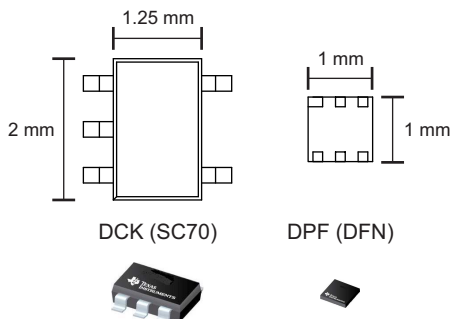

Package Height Comparison (To Scale)

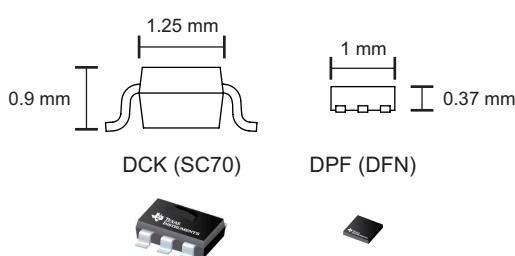

Please be aware that an important notice concerning availability, standard warranty, and use in critical applications of Texas Instruments semiconductor products and disclaimers thereto appears at the end of this data sheet.



This integrated circuit can be damaged by ESD. Texas Instruments recommends that all integrated circuits be handled with appropriate precautions. Failure to observe proper handling and installation procedures can cause damage.

ESD damage can range from subtle performance degradation to complete device failure. Precision integrated circuits may be more susceptible to damage because very small parametric changes could cause the device not to meet its published specifications.

ORDERING INFORMATION⁽¹⁾

- (1) For the most current package and ordering information, see the Package Option Addendum at the end of this document, or visit the device product folder at www.ti.com.

ABSOLUTE MAXIMUM RATINGS⁽¹⁾

		MIN	MAX	UNIT
Supply voltage			+7	V
Signal input terminals	Voltage ⁽²⁾	(V ₋) – 0.5	(V ₊) + 0.5	V
	Current ⁽²⁾		±10	mA
Output short-circuit ⁽³⁾		continuous		mA
Temperature	Operating, T _A	–55	+150	°C
	Storage, T _{stg}	–65	+150	°C
	Junction, T _J		+150	°C
Electrostatic discharge (ESD) ratings	Human body model (HBM)		2.5	kV
	Charged-device model (CDM)		1	kV

- (1) Stresses beyond those listed under *Absolute Maximum Ratings* may cause permanent damage to the device. These are stress ratings only, and do not imply functional operation of the device at these or any other conditions. Exposure to absolute-maximum-rated conditions for extended periods may affect device reliability.
- (2) Input terminals are diode-clamped to the power-supply rails. Input signals that can swing more than 0.5 V beyond the supply rails should be current-limited to 10 mA or less.
- (3) Short-circuit to ground, one comparator per package.

THERMAL INFORMATION

THERMAL METRIC ⁽¹⁾		TLV3691		UNITS
		DCK (SC70)	DPF (DFN)	
		5 PINS	6 PINS	
θ _{JA}	Junction-to-ambient thermal resistance	297.4	252.4	°C/W
θ _{JCtop}	Junction-to-case (top) thermal resistance	109.3	93.9	
θ _{JB}	Junction-to-board thermal resistance	74.4	192.8	
ψ _{JT}	Junction-to-top characterization parameter	3.0	3.0	
ψ _{JB}	Junction-to-board characterization parameter	73.6	203.8	
θ _{JCbot}	Junction-to-case (bottom) thermal resistance	N/A	N/A	

- (1) For more information about traditional and new thermal metrics, see the *IC Package Thermal Metrics* application report, [SPRA953](http://www.ti.com/lit/zip/spra953).

ELECTRICAL CHARACTERISTICS: $V_S = +0.9\text{ V to }+6.5\text{ V}$

At $T_A = +25^\circ\text{C}$, $V_S = +0.9\text{ V to }+6.5\text{ V}$, $V_{CM} = V_S/2$ and $C_L = 15\text{ pF}$, unless otherwise noted.

PARAMETER		TEST CONDITIONS	MIN	TYP	MAX	UNIT
OFFSET VOLTAGE						
V_{OS}	Input offset voltage			±3	±15	mV
		$T_A = -40^\circ\text{C to }+125^\circ\text{C}$			±22	mV
dV_{OS}/dT	Input offset voltage drift	$T_A = -40^\circ\text{C to }+125^\circ\text{C}$			±70	$\mu\text{V}/^\circ\text{C}$
PSRR	Power-supply rejection ratio	$T_A = -40^\circ\text{C to }+125^\circ\text{C}$			2000	$\mu\text{V}/\text{V}$
INPUT VOLTAGE RANGE						
V_{CM}	Common-mode voltage range	$T_A = -40^\circ\text{C to }+125^\circ\text{C}$	(V-) - 0.1		(V+) + 0.1	V
	Hysteresis			±17		mV
INPUT BIAS CURRENT						
I_B	Input bias current			30	100	pA
		$T_A = -40^\circ\text{C to }+125^\circ\text{C}$			20	nA
I_{OS}	Input offset current			8		pA
C_{LOAD}	Capacitive load drive		See Typical Characteristics			
OUTPUT						
V_{OH}	Voltage output swing from upper rail	$I_O = 2.5\text{ mA}$, input overdrive $\geq 50\text{ mV}$, $V_S = 6.5\text{ V}$		155	165	mV
		$I_O = 2.5\text{ mA}$, input overdrive $\geq 50\text{ mV}$, $V_S = 6.5\text{ V}$, $T_A = -40^\circ\text{C to }+125^\circ\text{C}$			220	mV
		$I_O \leq 100\ \mu\text{A}$, input overdrive $\geq 50\text{ mV}$, $V_S = 6.5\text{ V}$		6	10	mV
		$I_O \leq 100\ \mu\text{A}$, input overdrive $\geq 50\text{ mV}$, $V_S = 6.5\text{ V}$, $T_A = -40^\circ\text{C to }+125^\circ\text{C}$			20	mV
		$I_O \leq 100\ \mu\text{A}$, input overdrive $\geq 50\text{ mV}$, $V_S = 0.9\text{ V}$		70	75	mV
		$I_O \leq 100\ \mu\text{A}$, input overdrive $\geq 50\text{ mV}$, $V_S = 0.9\text{ V}$, $T_A = -40^\circ\text{C to }+125^\circ\text{C}$			80	mV
V_{OL}	Voltage output swing from lower rail	$I_O = 2.5\text{ mA}$, input overdrive $\geq 50\text{ mV}$, $V_S = 6.5\text{ V}$		155	165	mV
		$I_O = 2.5\text{ mA}$, input overdrive $\geq 50\text{ mV}$, $V_S = 6.5\text{ V}$, $T_A = -40^\circ\text{C to }+125^\circ\text{C}$			220	mV
		$I_O \leq 100\ \mu\text{A}$, input overdrive $\geq 50\text{ mV}$, $V_S = 6.5\text{ V}$		6	10	mV
		$I_O \leq 100\ \mu\text{A}$, input overdrive $\geq 50\text{ mV}$, $V_S = 6.5\text{ V}$, $T_A = -40^\circ\text{C to }+125^\circ\text{C}$			20	mV
		$I_O \leq 100\ \mu\text{A}$, input overdrive $\geq 50\text{ mV}$, $V_S = 0.9\text{ V}$		35	40	mV
		$I_O \leq 100\ \mu\text{A}$, input overdrive $\geq 50\text{ mV}$, $V_S = 0.9\text{ V}$, $T_A = -40^\circ\text{C to }+125^\circ\text{C}$			45	mV
I_{SC}	Short circuit sink current	$V_S = 6.5\text{ V}$, see Typical Characteristics		42		mA
	Short circuit source current	$V_S = 6.5\text{ V}$, see Typical Characteristics		35		mA

ELECTRICAL CHARACTERISTICS: $V_S = +0.9\text{ V to }+6.5\text{ V}$ (continued)

At $T_A = +25^\circ\text{C}$, $V_S = +0.9\text{ V to }+6.5\text{ V}$, $V_{CM} = V_S/2$ and $C_L = 15\text{ pF}$, unless otherwise noted.

PARAMETER		TEST CONDITIONS	MIN	TYP	MAX	UNIT
SWITCHING CHARACTERISTICS						
t_{PHL}	Propagation delay time	High to low	$V_S = 6.5\text{ V}$, Input overdrive = 50 mV		32	μs
			$V_S = 0.9\text{ V}$, Input overdrive = 50 mV		45	μs
			$V_S = 6.5\text{ V}$, Input overdrive = 100 mV		24	μs
			$V_S = 0.9\text{ V}$, Input overdrive = 100 mV		35	μs
t_{PLH}		Low to high	$V_S = 6.5\text{ V}$, Input overdrive = 50 mV		32	μs
			$V_S = 0.9\text{ V}$, Input overdrive = 50 mV		40	μs
			$V_S = 6.5\text{ V}$, Input overdrive = 100 mV		24	μs
			$V_S = 0.9\text{ V}$, Input overdrive = 100 mV		28	μs
t_R	Rise time	Input overdrive = 100 mV		330	ns	
t_F	Fall time	Input overdrive = 100 mV		330	ns	
POWER SUPPLY						
V_S	Specified voltage range			0.9	6.5	V
I_Q	Quiescent current (per channel)			75	150	nA
		$T_A = -40^\circ\text{C to }+125^\circ\text{C}$			200	nA
TEMPERATURE RANGE						
Specified range				-40	+125	$^\circ\text{C}$
Operating range				-55	+150	$^\circ\text{C}$
Storage range				-65	+150	$^\circ\text{C}$

PIN CONFIGURATIONS

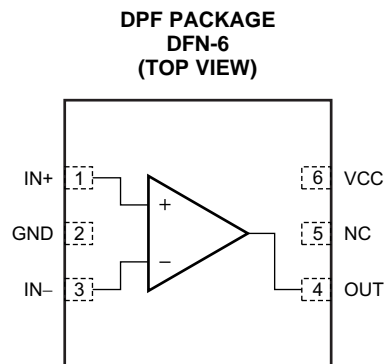
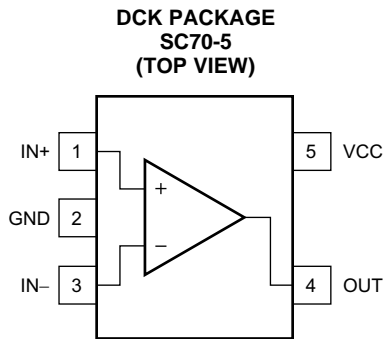

NOTE: NC = no connection.

TYPICAL CHARACTERISTICS

At $T_A = +25^\circ\text{C}$, $V_S = +0.9\text{ V}$ to $+6.5\text{ V}$, and input overdrive = 100 mV, unless otherwise noted.

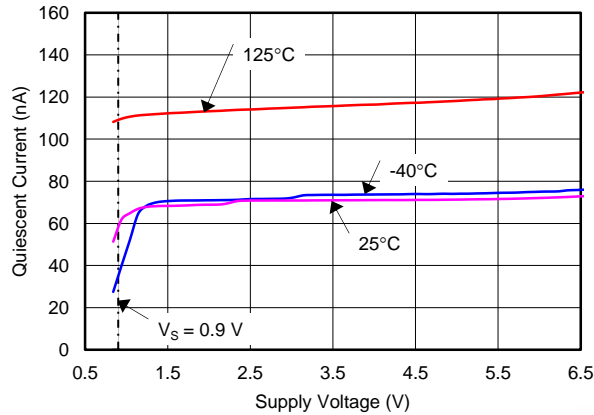

Figure 1. QUIESCENT CURRENT vs SUPPLY VOLTAGE

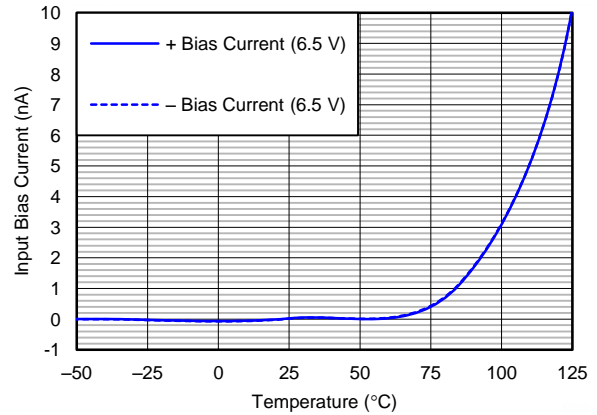

Figure 2. INPUT BIAS CURRENT vs TEMPERATURE

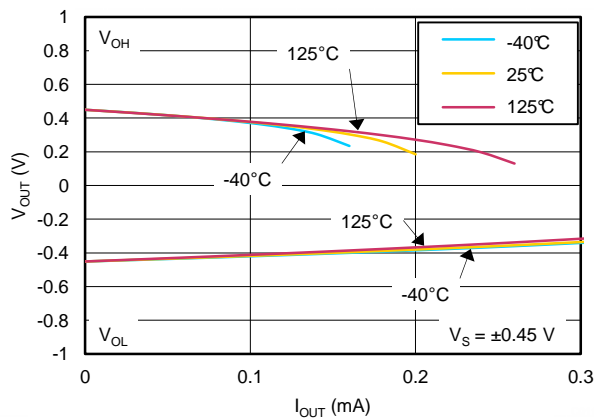

Figure 3. OUTPUT VOLTAGE vs OUTPUT CURRENT ($V_S = 0.9\text{ V}$)

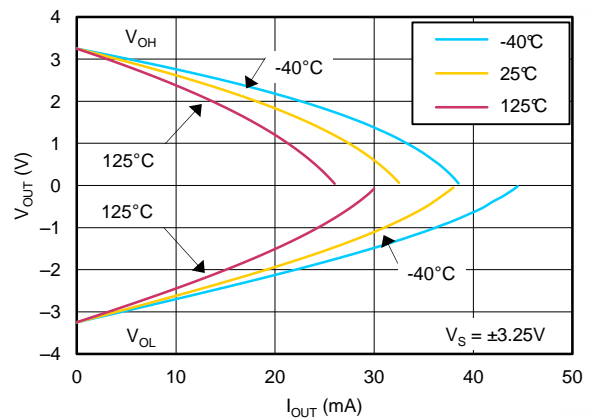

Figure 4. OUTPUT VOLTAGE vs OUTPUT CURRENT ($V_S = \pm 3.25\text{ V}$)

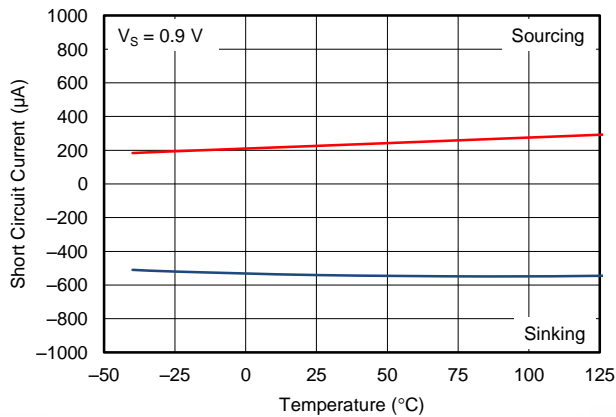

Figure 5. SHORT-CIRCUIT CURRENT vs TEMPERATURE ($V_S = 0.9\text{ V}$)

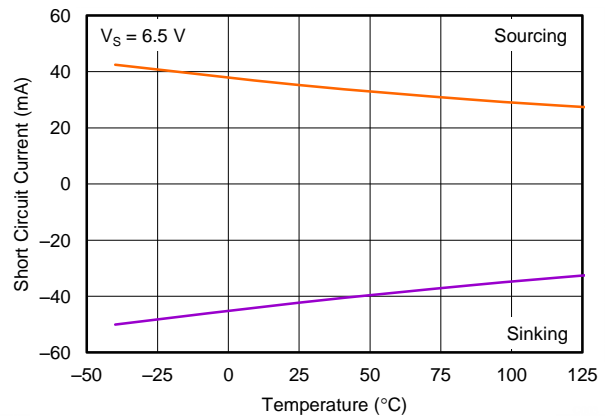

Figure 6. SHORT-CIRCUIT CURRENT vs TEMPERATURE ($V_S = 6.5\text{ V}$)

TYPICAL CHARACTERISTICS (continued)

At $T_A = +25^\circ\text{C}$, $V_S = +0.9\text{ V}$ to $+6.5\text{ V}$, and input overdrive = 100 mV, unless otherwise noted.

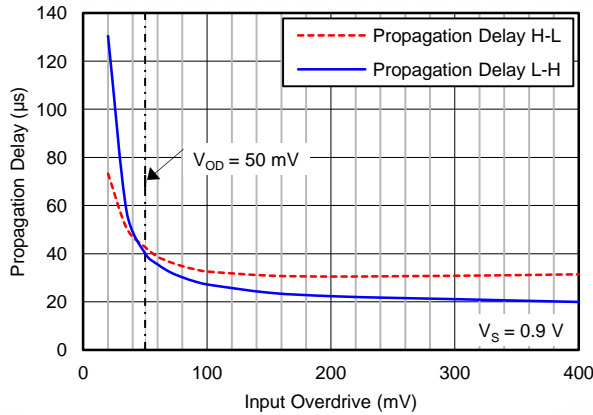

Figure 7. PROPAGATION DELAY vs INPUT OVERDRIVE ($V_S = 0.9\text{ V}$)

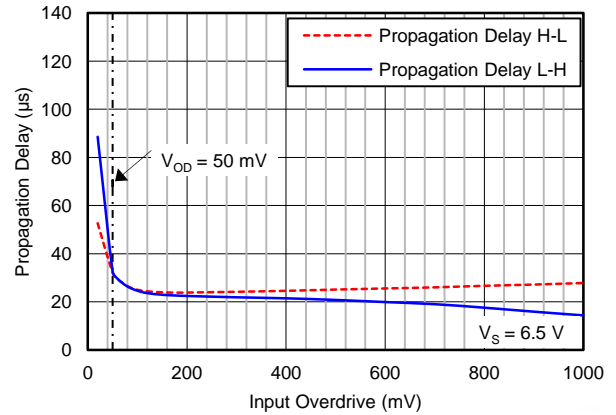

Figure 8. PROPAGATION DELAY vs INPUT OVERDRIVE ($V_S = 6.5\text{ V}$)

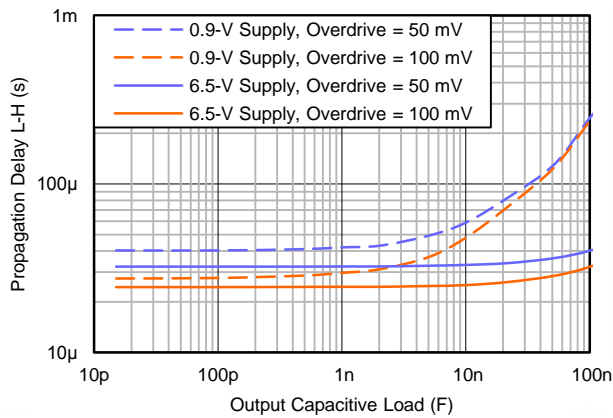

Figure 9. PROPAGATION DELAY (t_{PLH}) vs CAPACITIVE LOAD

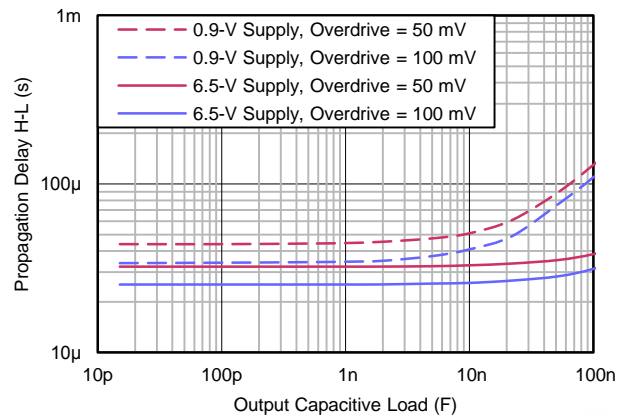

Figure 10. PROPAGATION DELAY (t_{PHL}) vs CAPACITIVE LOAD

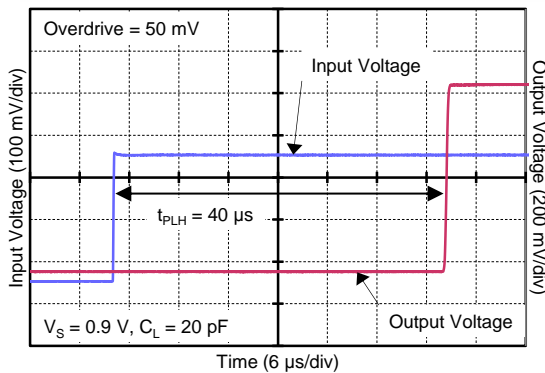

Figure 11. PROPAGATION DELAY (t_{PLH}) ($V_S = 0.9\text{ V}$, Overdrive = 50 mV)

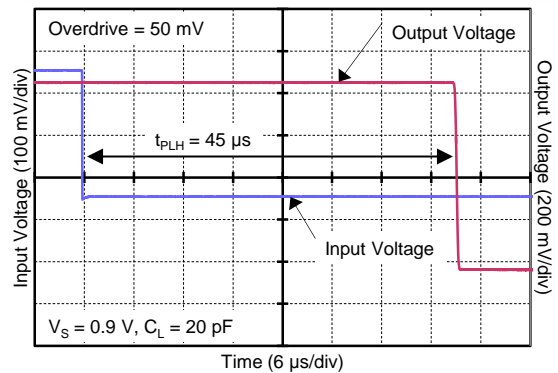

Figure 12. PROPAGATION DELAY (t_{PHL}) ($V_S = 0.9\text{ V}$, Overdrive = 50 mV)

TYPICAL CHARACTERISTICS (continued)

At $T_A = +25^\circ\text{C}$, $V_S = +0.9\text{ V}$ to $+6.5\text{ V}$, and input overdrive = 100 mV, unless otherwise noted.

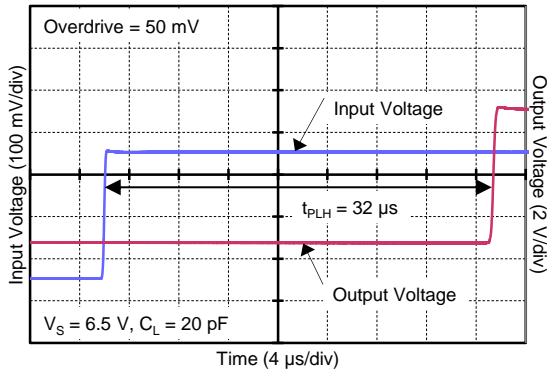

Figure 13. PROPAGATION DELAY (t_{PLH})
($V_S = 6.5\text{ V}$, Overdrive = 50 mV)

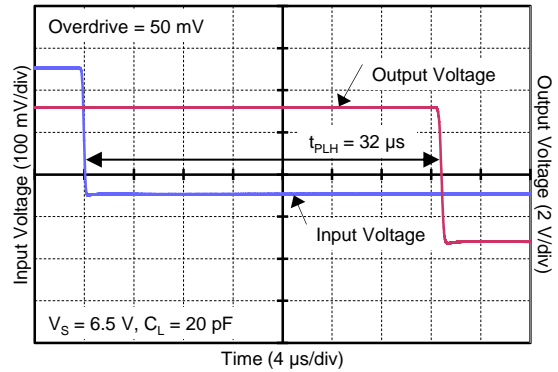

Figure 14. PROPAGATION DELAY (t_{PHL})
($V_S = 6.5\text{ V}$, Overdrive = 50 mV)

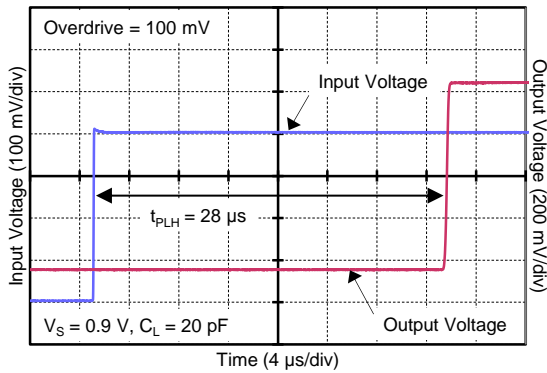

Figure 15. PROPAGATION DELAY (t_{PLH})
($V_S = 0.9\text{ V}$, Overdrive = 100 mV)

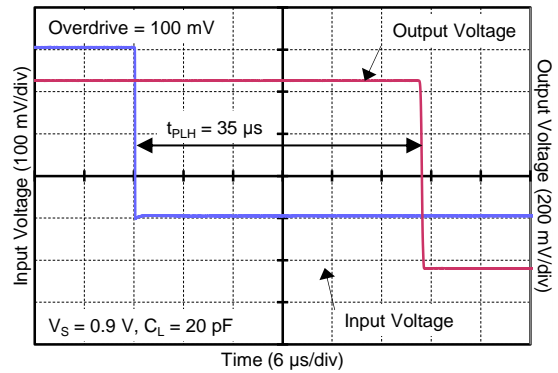

Figure 16. PROPAGATION DELAY (t_{PHL})
($V_S = 0.9\text{ V}$, Overdrive = 100 mV)

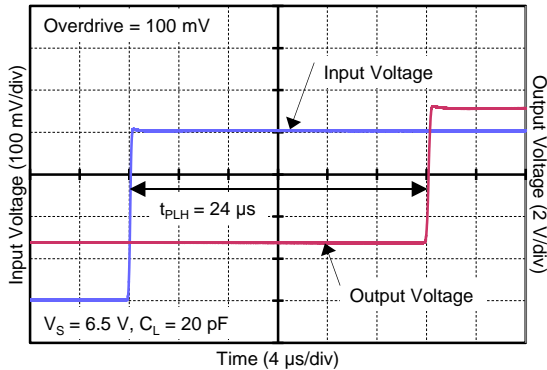

Figure 17. PROPAGATION DELAY (t_{PLH})
($V_S = 6.5\text{ V}$, Overdrive = 100 mV)

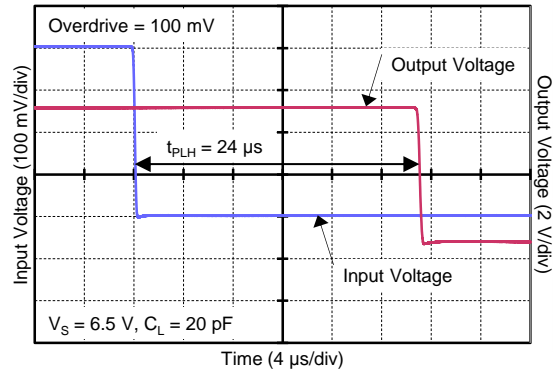

Figure 18. PROPAGATION DELAY (t_{PHL})
($V_S = 6.5\text{ V}$, Overdrive = 100 mV)

TYPICAL CHARACTERISTICS (continued)

At $T_A = +25^\circ\text{C}$, $V_S = +0.9\text{ V}$ to $+6.5\text{ V}$, and input overdrive = 100 mV, unless otherwise noted.

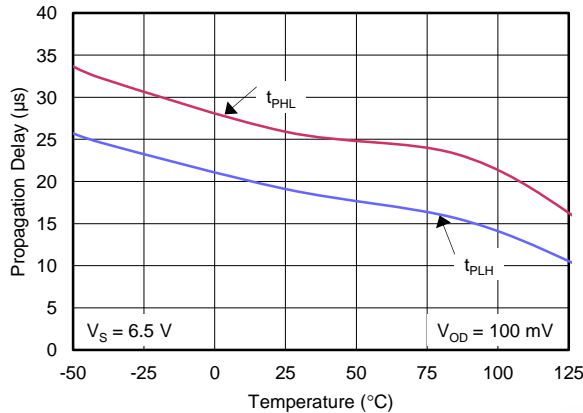

Figure 19. PROPAGATION DELAY vs TEMPERATURE

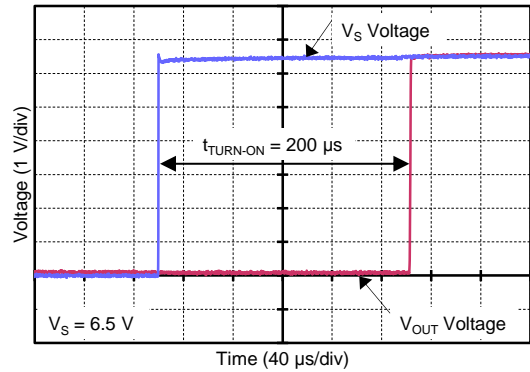

Figure 20. START-UP TIME

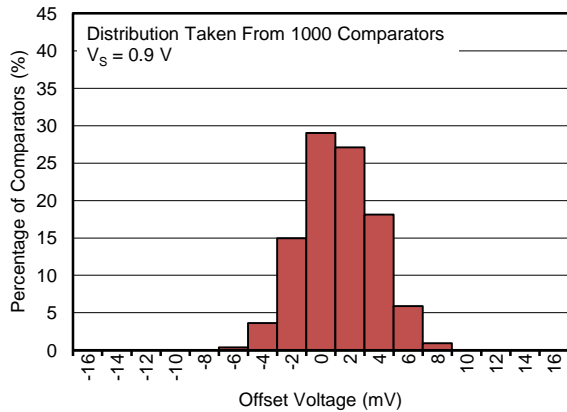

Figure 21. OFFSET VOLTAGE PRODUCTION DISTRIBUTION ($V_S = 0.9\text{ V}$)

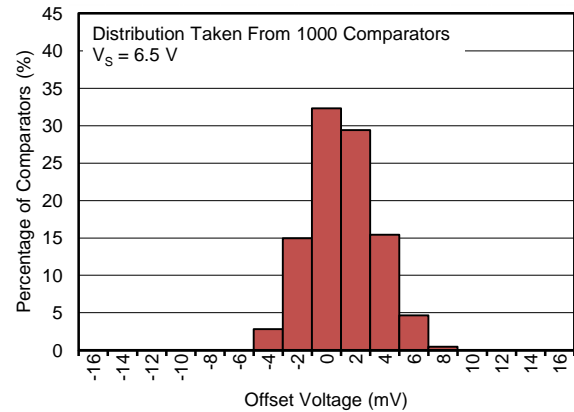

Figure 22. OFFSET VOLTAGE PRODUCTION DISTRIBUTION ($V_S = 6.5\text{ V}$)

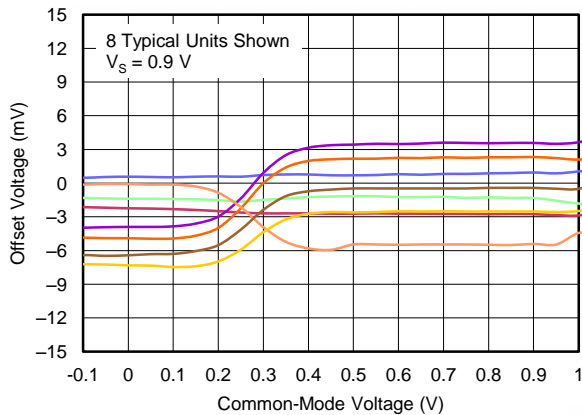

Figure 23. OFFSET VOLTAGE vs COMMON-MODE VOLTAGE ($V_S = 0.9\text{ V}$)

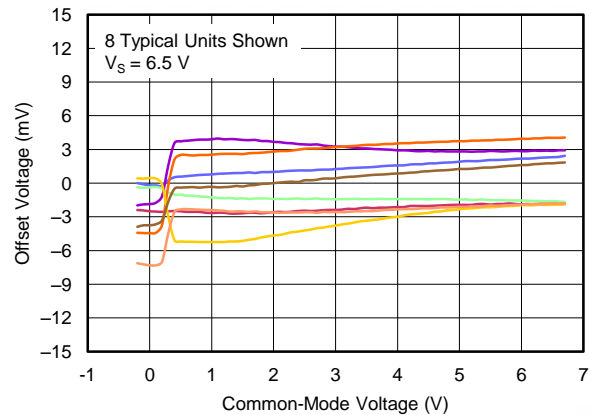
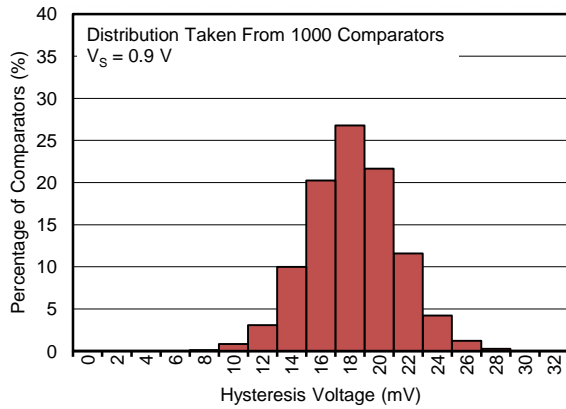

Figure 24. OFFSET VOLTAGE vs COMMON-MODE VOLTAGE ($V_S = 6.5\text{ V}$)

TYPICAL CHARACTERISTICS (continued)

At $T_A = +25^\circ\text{C}$, $V_S = +0.9\text{ V}$ to $+6.5\text{ V}$, and input overdrive = 100 mV, unless otherwise noted.



**Figure 25. HYSTERESIS PRODUCTION DISTRIBUTION
($V_S = 0.9\text{ V}$)**

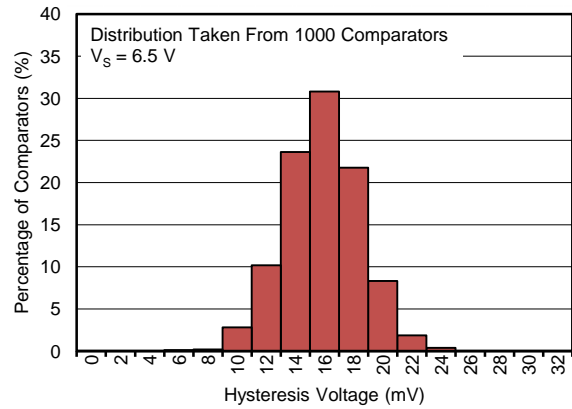

**Figure 26. HYSTERESIS PRODUCTION DISTRIBUTION
($V_S = 6.5\text{ V}$)**

APPLICATION INFORMATION

The TLV3691 comparators feature rail-to-rail inputs and outputs on supply voltages as low as 0.9 V. The push-pull output stage is optimal for reduced power budget applications and features no shoot-through current. Low minimum supply voltages, common-mode input range beyond supply rails, and a typical supply current of 75 nA make the TLV3691 an excellent candidate for battery-operated and portable, handheld designs.

COMPARATOR INPUTS

The TLV3691 is a rail-to-rail input comparator, with an input common-mode range that exceeds the supply rails by 100 mV for both positive and negative supplies. The device is designed to prevent phase inversion when the input pins exceed the supply voltage. Figure 27 shows the device response when input voltages exceed the supply, resulting in no phase inversion.

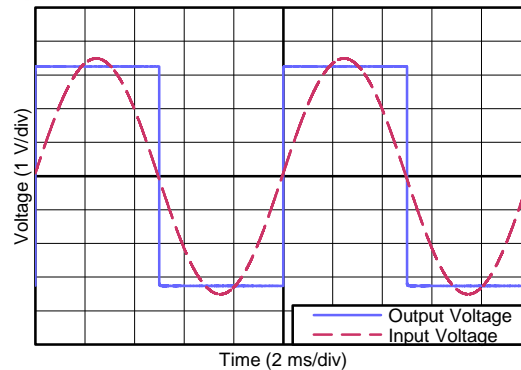

Figure 27. No Phase Inversion: Comparator Response to Input Voltage (Propagation Delay Included)

EXTERNAL HYSTERESIS

The device hysteresis transfer curve is shown in Figure 28. This curve is a function of three components: V_{TH} , V_{OS} , and V_{HYST} .

- V_{TH} is the actual set voltage or threshold trip voltage.
- V_{OS} is the internal offset voltage between V_{IN+} and V_{IN-} . This voltage is added to V_{TH} to form the actual trip point at which the comparator must respond in order to change output states.
- V_{HYST} is the internal hysteresis (or trip window) that is designed to reduce comparator sensitivity to noise (17 mV for the TLV3691).

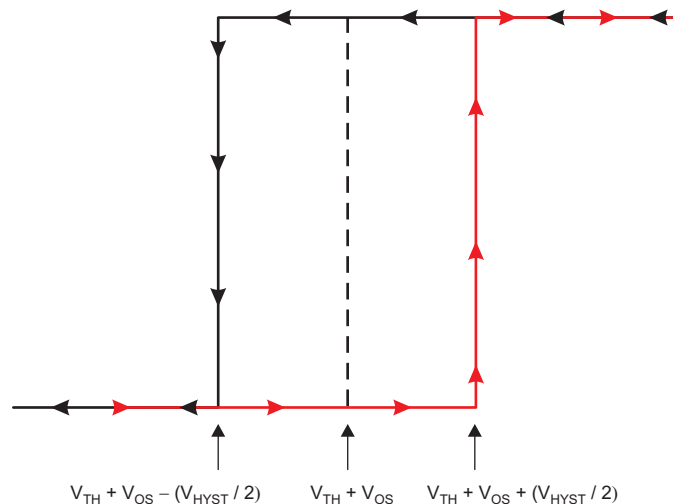

Figure 28. Hysteresis Transfer Curve

Inverting Comparator With Hysteresis

The inverting comparator with hysteresis requires a three-resistor network that is referenced to the comparator supply voltage (V_{CC}), as shown in [Figure 29](#). When V_{IN} at the inverting input is less than V_A , the output voltage is high (for simplicity, assume V_O switches as high as V_{CC}). The three network resistors can be represented as $R1 \parallel R3$ in series with $R2$. The high to low trip voltage (V_{A1}) is defined by [Equation 1](#):

$$V_{A1} = V_{CC} \times \frac{R2}{(R1 \parallel R3) + R2} \tag{1}$$

When V_{IN} is greater than V_A , the output voltage is low, very close to ground. In this case, the three network resistors can be presented as $R2 \parallel R3$ in series with $R1$. The low to high trip voltage (V_{A2}) is defined by [Equation 2](#):

$$V_{A2} = V_{CC} \times \frac{R2 \parallel R3}{R1 + (R2 \parallel R3)} \tag{2}$$

The total hysteresis provided by the network is defined by [Equation 3](#):

$$\Delta V_A = V_{A1} - V_{A2} \tag{3}$$

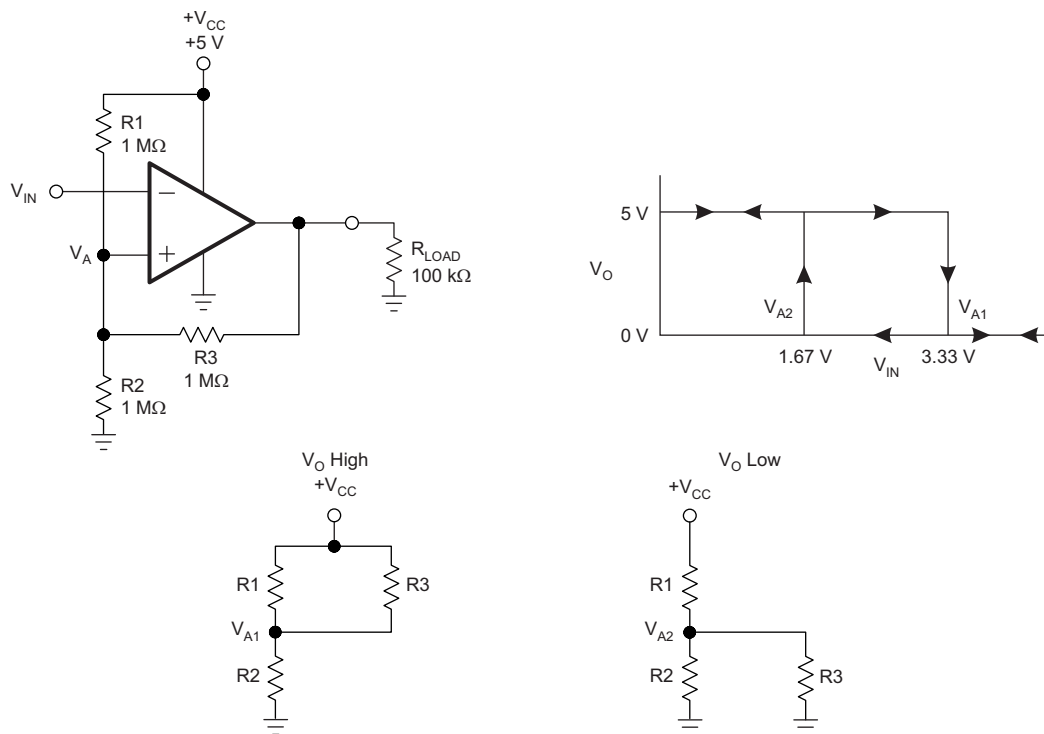

Figure 29. TLV3691 in an Inverting Configuration with Hysteresis

Noninverting Comparator with Hysteresis

A noninverting comparator with hysteresis requires a two-resistor network, as shown in Figure 30, and a voltage reference (V_{REF}) at the inverting input. When V_{IN} is low, the output is also low. For the output to switch from low to high, V_{IN} must rise to V_{IN1} . V_{IN1} is calculated by Equation 4:

$$V_{IN1} = R1 \times \frac{V_{REF}}{R2} + V_{REF} \quad (4)$$

When V_{IN} is high, the output is also high. In order for the comparator to switch back to a low state, V_{IN} must drop to V_{IN2} such that V_A is equal to V_{REF} . V_{IN2} can be calculated by Equation 5:

$$V_{IN2} = \frac{V_{REF} (R1 + R2) - V_{CC} \times R1}{R2} \quad (5)$$

The hysteresis of this circuit is the difference between V_{IN1} and V_{IN2} , as defined by Equation 6.

$$\Delta V_{IN} = V_{CC} \times \frac{R1}{R2} \quad (6)$$

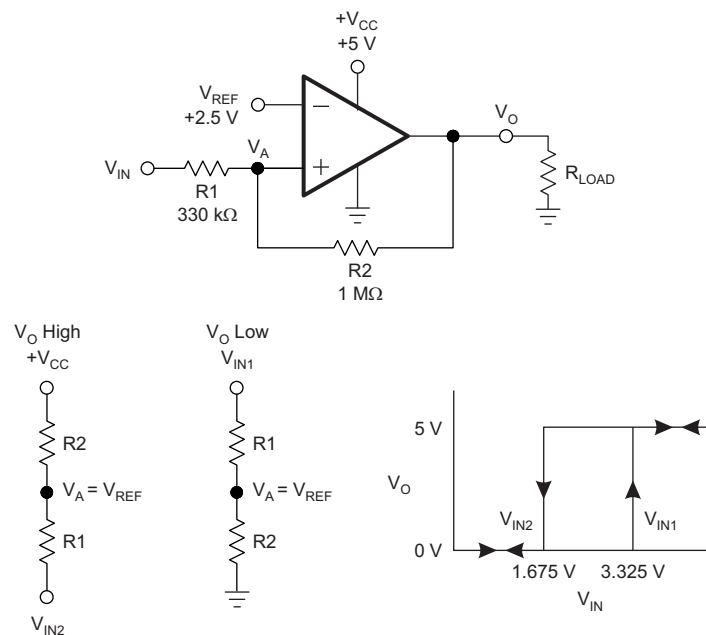

Figure 30. TLV3691 in a Noninverting Configuration with Hysteresis

CAPACITIVE LOADS

Under reasonable capacitive loads, the device maintains specified propagation delay (see the [Typical Characteristics](#)). However, excessive capacitive loading under high switching frequencies may increase supply current, propagation delay, or induce decreased slew rate.

CIRCUIT LAYOUT

Comparators are very sensitive to input noise. For best results, the following layout guidelines should be maintained:

1. Use a printed circuit board (PCB) with a good, unbroken, low-inductance ground plane. Proper grounding (use of a ground plane) helps maintain specified device performance.
2. To minimize supply noise, place a decoupling capacitor (0.1- μF ceramic, surface-mount capacitor) as close as possible to V_{CC} .
3. On the inputs and the output, keep lead lengths as short as possible to avoid unwanted parasitic feedback around the comparator. Keep inputs away from the output.
4. Solder the device directly to the PCB rather than using a socket.
5. For slow-moving input signals, take care to prevent parasitic feedback. A small capacitor (1000 pF or less) placed between the inputs can help eliminate oscillations in the transition region. This capacitor causes some degradation to propagation delay when impedance is low. The topside ground plane runs between the output and inputs.
6. The ground pin ground trace runs under the device up to the bypass capacitor, shielding the inputs from the outputs.

SETTING THE REFERENCE VOLTAGE

Using a stable reference when setting the transition point for the device is important. The [REF3312](#), as shown in [Figure 31](#), provides a 1.25-V reference voltage with low drift and only 3.9 μA of quiescent current.

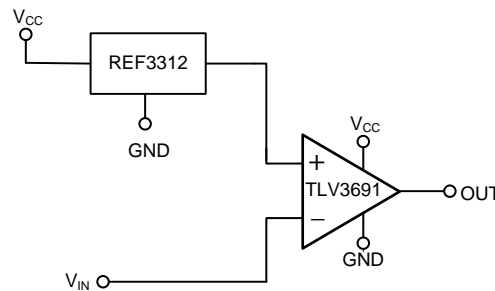

Figure 31. Reference Voltage for the TLV3691

APPLICATIONS

This section provides several example applications for the TLV3691.

Over- and Undervoltage Detection

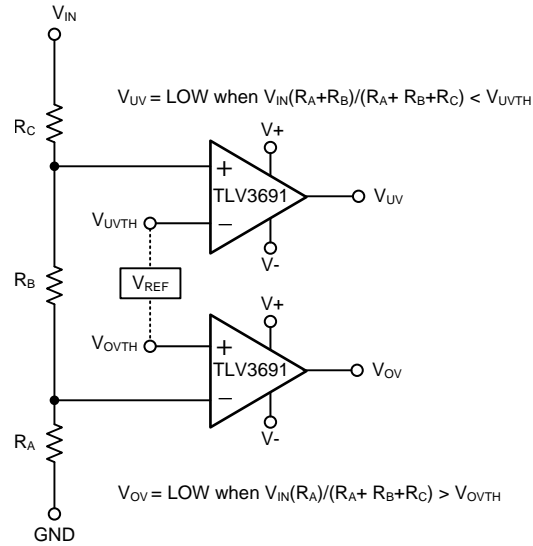

Figure 32. Over- and Undervoltage Detection

System Monitoring

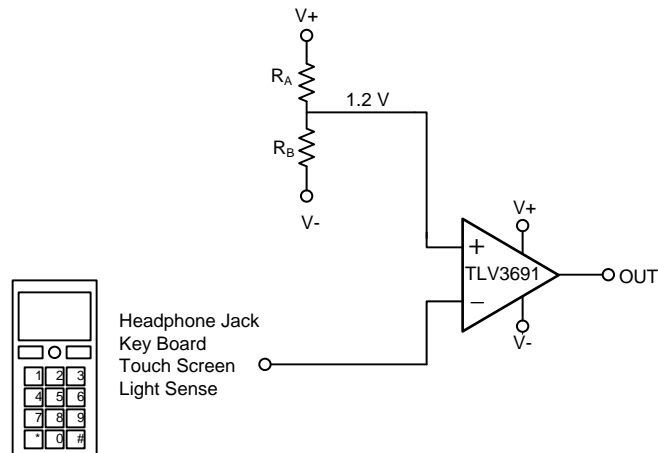

Figure 33. System Monitoring

Window Comparator

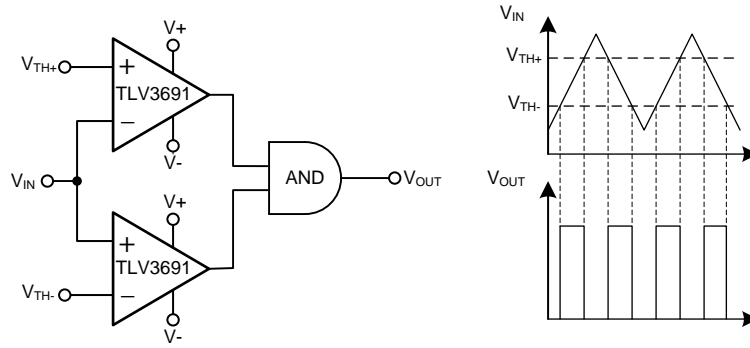

Figure 34. Window Comparator

PACKAGING INFORMATION

Orderable Device	Status (1)	Package Type	Package Drawing	Pins	Package Qty	Eco Plan (2)	Lead/Ball Finish (6)	MSL Peak Temp (3)	Op Temp (°C)	Device Marking (4/5)	Samples
TLV3691IDCKR	ACTIVE	SC70	DCK	5	3000	Green (RoHS & no Sb/Br)	CU NIPDAU	Level-2-260C-1 YEAR	-40 to 125	SIV	Samples
TLV3691IDCKT	ACTIVE	SC70	DCK	5	250	Green (RoHS & no Sb/Br)	CU NIPDAU	Level-2-260C-1 YEAR	-40 to 125	SIV	Samples
TLV3691IDPFR	ACTIVE	X2SON	DPF	6	5000	Green (RoHS & no Sb/Br)	CU NIPDAU	Level-1-260C-UNLIM	-40 to 125	EW	Samples
TLV3691IDPFT	ACTIVE	X2SON	DPF	6	250	Green (RoHS & no Sb/Br)	CU NIPDAU	Level-1-260C-UNLIM	-40 to 125	EW	Samples

(1) The marketing status values are defined as follows:

ACTIVE: Product device recommended for new designs.

LIFEBUY: TI has announced that the device will be discontinued, and a lifetime-buy period is in effect.

NRND: Not recommended for new designs. Device is in production to support existing customers, but TI does not recommend using this part in a new design.

PREVIEW: Device has been announced but is not in production. Samples may or may not be available.

OBSOLETE: TI has discontinued the production of the device.

(2) Eco Plan - The planned eco-friendly classification: Pb-Free (RoHS), Pb-Free (RoHS Exempt), or Green (RoHS & no Sb/Br) - please check <http://www.ti.com/productcontent> for the latest availability information and additional product content details.

TBD: The Pb-Free/Green conversion plan has not been defined.

Pb-Free (RoHS): TI's terms "Lead-Free" or "Pb-Free" mean semiconductor products that are compatible with the current RoHS requirements for all 6 substances, including the requirement that lead not exceed 0.1% by weight in homogeneous materials. Where designed to be soldered at high temperatures, TI Pb-Free products are suitable for use in specified lead-free processes.

Pb-Free (RoHS Exempt): This component has a RoHS exemption for either 1) lead-based flip-chip solder bumps used between the die and package, or 2) lead-based die adhesive used between the die and leadframe. The component is otherwise considered Pb-Free (RoHS compatible) as defined above.

Green (RoHS & no Sb/Br): TI defines "Green" to mean Pb-Free (RoHS compatible), and free of Bromine (Br) and Antimony (Sb) based flame retardants (Br or Sb do not exceed 0.1% by weight in homogeneous material)

(3) MSL, Peak Temp. - The Moisture Sensitivity Level rating according to the JEDEC industry standard classifications, and peak solder temperature.

(4) There may be additional marking, which relates to the logo, the lot trace code information, or the environmental category on the device.

(5) Multiple Device Markings will be inside parentheses. Only one Device Marking contained in parentheses and separated by a "~" will appear on a device. If a line is indented then it is a continuation of the previous line and the two combined represent the entire Device Marking for that device.

(6) Lead/Ball Finish - Orderable Devices may have multiple material finish options. Finish options are separated by a vertical ruled line. Lead/Ball Finish values may wrap to two lines if the finish value exceeds the maximum column width.

Important Information and Disclaimer: The information provided on this page represents TI's knowledge and belief as of the date that it is provided. TI bases its knowledge and belief on information provided by third parties, and makes no representation or warranty as to the accuracy of such information. Efforts are underway to better integrate information from third parties. TI has taken and continues to take reasonable steps to provide representative and accurate information but may not have conducted destructive testing or chemical analysis on incoming materials and chemicals. TI and TI suppliers consider certain information to be proprietary, and thus CAS numbers and other limited information may not be available for release.

In no event shall TI's liability arising out of such information exceed the total purchase price of the TI part(s) at issue in this document sold by TI to Customer on an annual basis.

TAPE AND REEL INFORMATION



QUADRANT ASSIGNMENTS FOR PIN 1 ORIENTATION IN TAPE



*All dimensions are nominal

Device	Package Type	Package Drawing	Pins	SPQ	Reel Diameter (mm)	Reel Width W1 (mm)	A0 (mm)	B0 (mm)	K0 (mm)	P1 (mm)	W (mm)	Pin1 Quadrant
TLV3691IDCKR	SC70	DCK	5	3000	178.0	9.0	2.4	2.5	1.2	4.0	8.0	Q3
TLV3691IDCKT	SC70	DCK	5	250	178.0	8.4	2.4	2.5	1.2	4.0	8.0	Q3
TLV3691IDPFR	X2SON	DPF	6	5000	180.0	9.5	1.16	1.16	0.63	4.0	8.0	Q2
TLV3691IDPFT	X2SON	DPF	6	250	180.0	9.5	1.16	1.16	0.63	4.0	8.0	Q2

TAPE AND REEL BOX DIMENSIONS

*All dimensions are nominal

Device	Package Type	Package Drawing	Pins	SPQ	Length (mm)	Width (mm)	Height (mm)
TLV3691IDCKR	SC70	DCK	5	3000	190.0	190.0	30.0
TLV3691IDCKT	SC70	DCK	5	250	190.0	190.0	30.0
TLV3691IDPFR	X2SON	DPF	6	5000	184.0	184.0	19.0
TLV3691IDPFT	X2SON	DPF	6	250	184.0	184.0	19.0

DCK (R-PDSO-G5)

PLASTIC SMALL OUTLINE

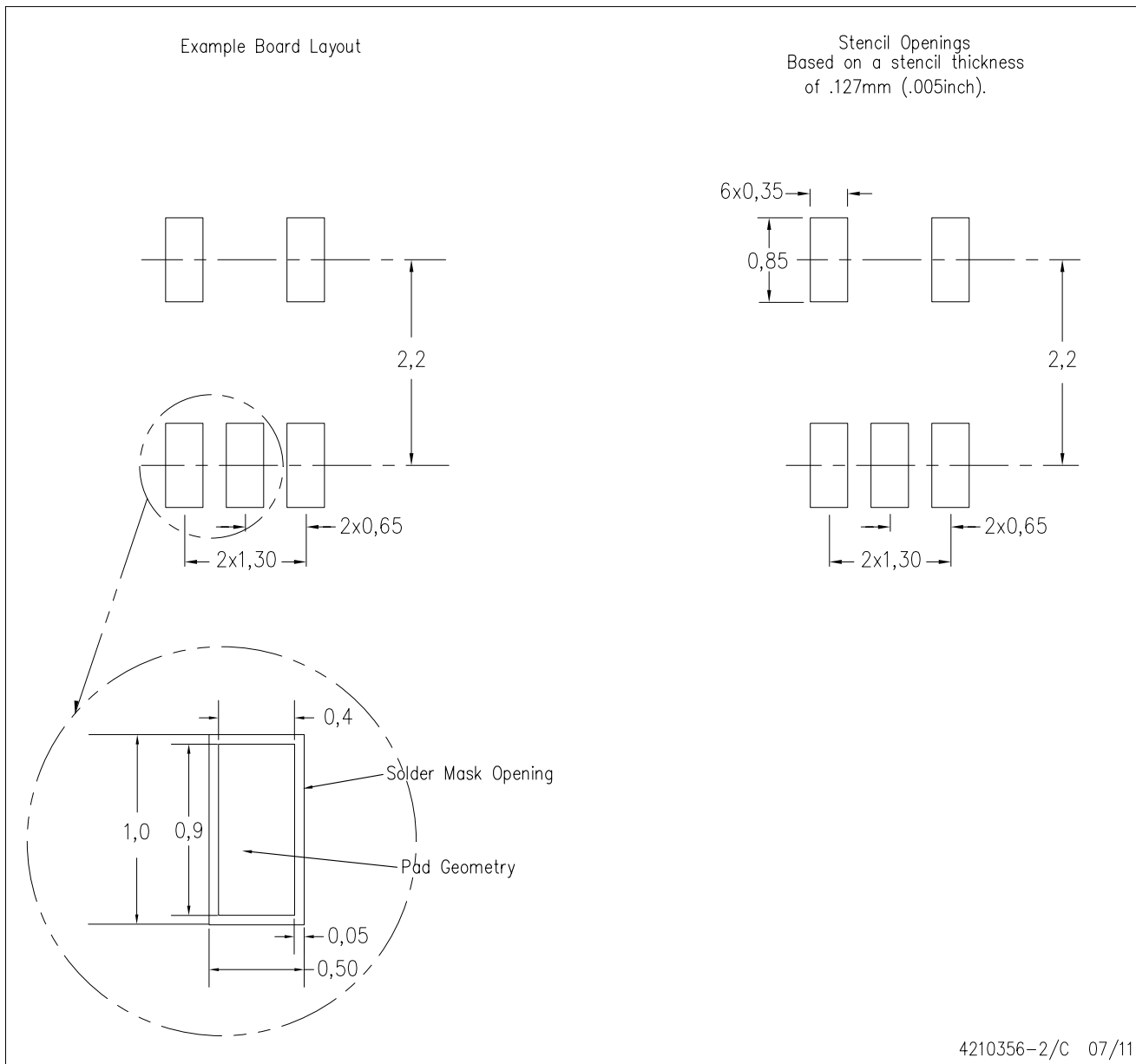

- NOTES:
- A. All linear dimensions are in millimeters.
 - B. This drawing is subject to change without notice.
 - C. Customers should place a note on the circuit board fabrication drawing not to alter the center solder mask defined pad.
 - D. Publication IPC-7351 is recommended for alternate designs.
 - E. Laser cutting apertures with trapezoidal walls and also rounding corners will offer better paste release. Customers should contact their board assembly site for stencil design recommendations. Example stencil design based on a 50% volumetric metal load solder paste. Refer to IPC-7525 for other stencil recommendations.

DPF (S-PX2SON-N6)

PLASTIC SMALL OUTLINE NO-LEAD

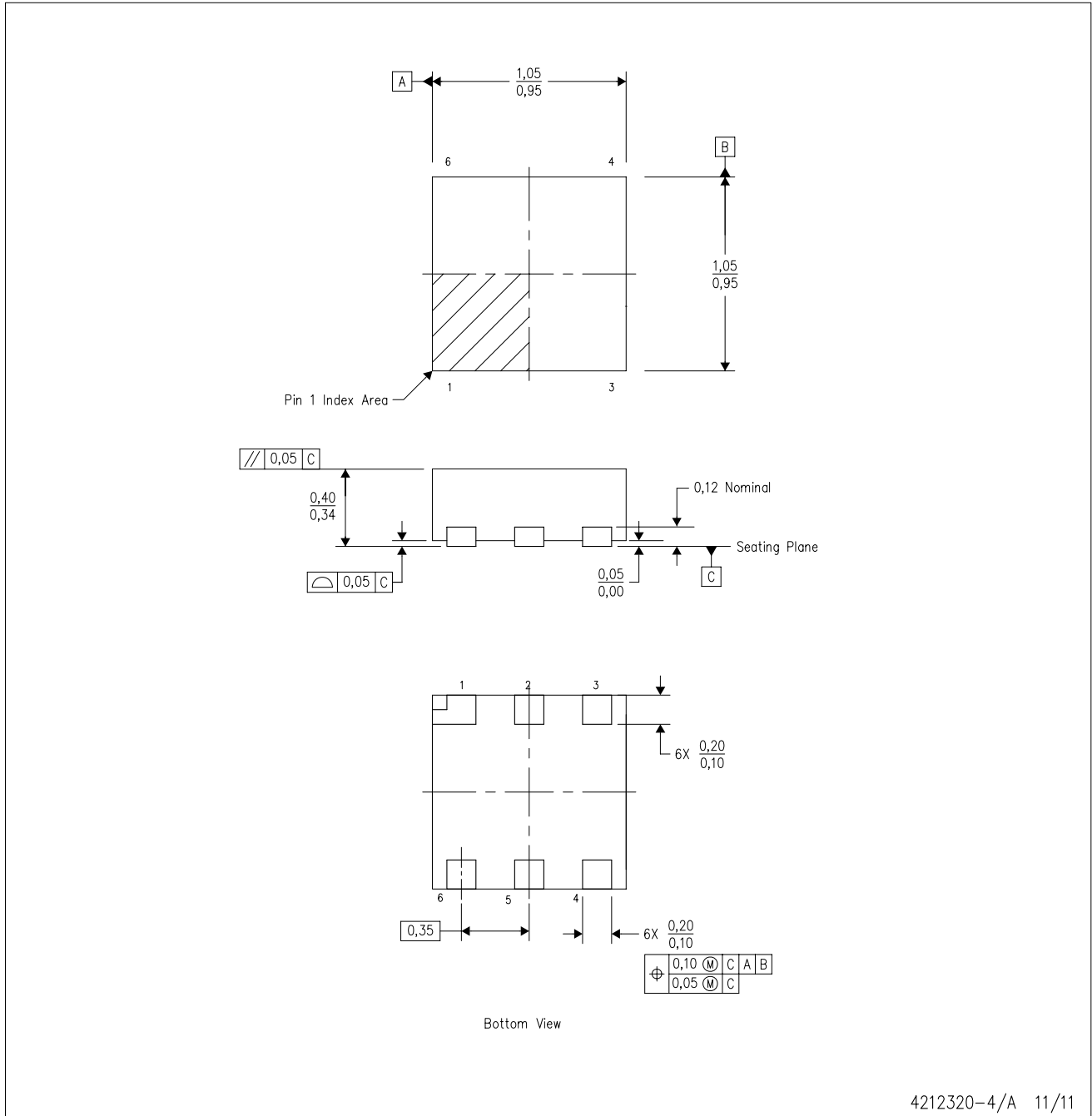

4212320-4/A 11/11

- NOTES:
- A. All linear dimensions are in millimeters. Dimensioning and tolerancing per ASME Y14.5M-1994.
 - B. This drawing is subject to change without notice.
 - C. SON (Small Outline No-Lead) package configuration.

IMPORTANT NOTICE

Texas Instruments Incorporated and its subsidiaries (TI) reserve the right to make corrections, enhancements, improvements and other changes to its semiconductor products and services per JESD46, latest issue, and to discontinue any product or service per JESD48, latest issue. Buyers should obtain the latest relevant information before placing orders and should verify that such information is current and complete. All semiconductor products (also referred to herein as "components") are sold subject to TI's terms and conditions of sale supplied at the time of order acknowledgment.

TI warrants performance of its components to the specifications applicable at the time of sale, in accordance with the warranty in TI's terms and conditions of sale of semiconductor products. Testing and other quality control techniques are used to the extent TI deems necessary to support this warranty. Except where mandated by applicable law, testing of all parameters of each component is not necessarily performed.

TI assumes no liability for applications assistance or the design of Buyers' products. Buyers are responsible for their products and applications using TI components. To minimize the risks associated with Buyers' products and applications, Buyers should provide adequate design and operating safeguards.

TI does not warrant or represent that any license, either express or implied, is granted under any patent right, copyright, mask work right, or other intellectual property right relating to any combination, machine, or process in which TI components or services are used. Information published by TI regarding third-party products or services does not constitute a license to use such products or services or a warranty or endorsement thereof. Use of such information may require a license from a third party under the patents or other intellectual property of the third party, or a license from TI under the patents or other intellectual property of TI.

Reproduction of significant portions of TI information in TI data books or data sheets is permissible only if reproduction is without alteration and is accompanied by all associated warranties, conditions, limitations, and notices. TI is not responsible or liable for such altered documentation. Information of third parties may be subject to additional restrictions.

Resale of TI components or services with statements different from or beyond the parameters stated by TI for that component or service voids all express and any implied warranties for the associated TI component or service and is an unfair and deceptive business practice. TI is not responsible or liable for any such statements.

Buyer acknowledges and agrees that it is solely responsible for compliance with all legal, regulatory and safety-related requirements concerning its products, and any use of TI components in its applications, notwithstanding any applications-related information or support that may be provided by TI. Buyer represents and agrees that it has all the necessary expertise to create and implement safeguards which anticipate dangerous consequences of failures, monitor failures and their consequences, lessen the likelihood of failures that might cause harm and take appropriate remedial actions. Buyer will fully indemnify TI and its representatives against any damages arising out of the use of any TI components in safety-critical applications.

In some cases, TI components may be promoted specifically to facilitate safety-related applications. With such components, TI's goal is to help enable customers to design and create their own end-product solutions that meet applicable functional safety standards and requirements. Nonetheless, such components are subject to these terms.

No TI components are authorized for use in FDA Class III (or similar life-critical medical equipment) unless authorized officers of the parties have executed a special agreement specifically governing such use.

Only those TI components which TI has specifically designated as military grade or "enhanced plastic" are designed and intended for use in military/aerospace applications or environments. Buyer acknowledges and agrees that any military or aerospace use of TI components which have **not** been so designated is solely at the Buyer's risk, and that Buyer is solely responsible for compliance with all legal and regulatory requirements in connection with such use.

TI has specifically designated certain components as meeting ISO/TS16949 requirements, mainly for automotive use. In any case of use of non-designated products, TI will not be responsible for any failure to meet ISO/TS16949.

Products

Audio	www.ti.com/audio
Amplifiers	amplifier.ti.com
Data Converters	dataconverter.ti.com
DLP® Products	www.dlp.com
DSP	dsp.ti.com
Clocks and Timers	www.ti.com/clocks
Interface	interface.ti.com
Logic	logic.ti.com
Power Mgmt	power.ti.com
Microcontrollers	microcontroller.ti.com
RFID	www.ti-rfid.com
OMAP Applications Processors	www.ti.com/omap
Wireless Connectivity	www.ti.com/wirelessconnectivity

Applications

Automotive and Transportation	www.ti.com/automotive
Communications and Telecom	www.ti.com/communications
Computers and Peripherals	www.ti.com/computers
Consumer Electronics	www.ti.com/consumer-apps
Energy and Lighting	www.ti.com/energy
Industrial	www.ti.com/industrial
Medical	www.ti.com/medical
Security	www.ti.com/security
Space, Avionics and Defense	www.ti.com/space-avionics-defense
Video and Imaging	www.ti.com/video

TI E2E Community

e2e.ti.com