

TLK2711-SP 1.6-Gbps to 2.5-Gbps Class V Transceiver

1 Features

- 1.6- to 2.5-Gbps (Gigabits Per Second) Serializer/Deserializer
- Hot-Plug Protection
- High-Performance 68-Pin Ceramic Quad Flat Pack Package (HFG)
- Low-Power Operation
- Programmable Preemphasis Levels on Serial Output
- Interfaces to Backplane, Copper Cables, or Optical Converters
- On-Chip 8-Bit/10-Bit Encoding/Decoding, Comma Detect
- On-Chip PLL Provides Clock Synthesis From Low-Speed Reference
- Low Power: <500 mW
- 3-V Tolerance on Parallel Data Input Signals
- 16-Bit Parallel TTL-Compatible Data Interface
- Ideal for High-Speed Backplane Interconnect and Point-to-Point Data Link
- Military Temperature Range (–55°C to 125°C T_{case})
- Loss of Signal (LOS) Detection
- Integrated 50-Ω Termination Resistors on RX
- Engineering Evaluation (EM) Samples are Available ⁽¹⁾

2 Applications

- Point-to-Point High Speed I/O
- Data Acquisition
- Data Processing

- (1) These units are intended for engineering evaluation only. They are processed to a non-compliant flow (for example, no burn-in, and so forth) and are tested to temperature rating of 25°C only. These units are not suitable for qualification, production, radiation testing, or flight use. Parts are not warranted for performance on full MIL specified temperature range of –55°C to 125°C or operating life.

3 Description

The TLK2711-SP is a member of the WizardLink transceiver family of multigigabit transceivers, intended for use in ultra-high-speed bidirectional point-to-point data transmission systems. The TLK2711-SP supports an effective serial interface speed of 1.6 Gbps to 2.5 Gbps, providing up to 2 Gbps of data bandwidth.

The primary application of the TLK2711-SP is to provide high-speed I/O data channels for point-to-point baseband data transmission over controlled impedance media of approximately 50 Ω. The transmission media can be printed circuit board, copper cables, or fiber-optic cable. The maximum rate and distance of data transfer is dependent upon the attenuation characteristics of the media and the noise coupling to the environment.

Device Information⁽¹⁾

PART NUMBER	PACKAGE	BODY SIZE (NOM)
TLK2711-SP	CFP (68)	13.97 mm x 13.97 mm

(1) For all available packages, see the orderable addendum at the end of the data sheet.

External Component Interconnection

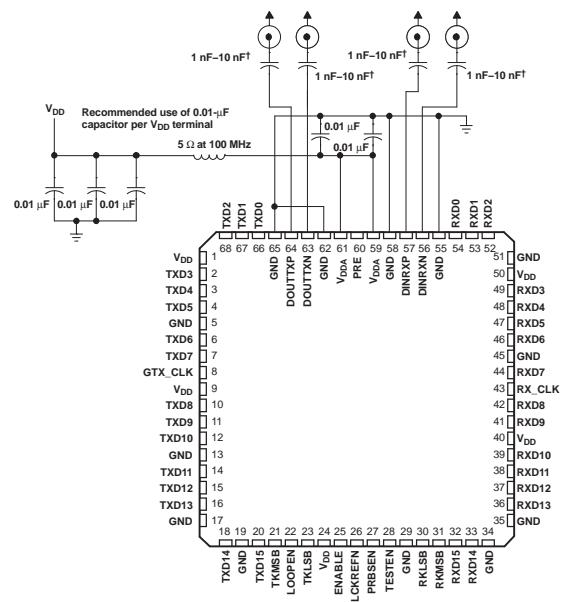

Table of Contents

1 Features 1 2 Applications 1 3 Description 1 4 Revision History 2 5 Description (continued) 3 6 Pin Configuration and Functions 4 7 Specifications 6 7.1 Absolute Maximum Ratings 6 7.2 Handling Ratings 6 7.3 Recommended Operating Conditions 7 7.4 Thermal Information 7 7.5 TTL Input Electrical Characteristics 7 7.6 Transmitter/Receiver Electrical Characteristics 8 7.7 Reference Clock (TXCLK) Timing Requirements 9 7.8 TTL Output Switching Characteristics 9 7.9 Typical Characteristics 11 8 Detailed Description 12	8.1 Overview 12 8.2 Functional Block Diagram 12 8.3 Feature Description 13 8.4 Device Functional Modes 20 9 Application and Implementation 21 9.1 Application Information 21 9.2 Typical Application 21 10 Power Supply Recommendations 23 11 Layout 23 11.1 Layout Guidelines 23 11.2 Layout Example 23 12 Device and Documentation Support 24 12.1 Trademarks 24 12.2 Electrostatic Discharge Caution 24 12.3 Glossary 24 13 Mechanical, Packaging, and Orderable Information 24
---	--

4 Revision History

NOTE: Page numbers for previous revisions may differ from page numbers in the current version.

Changes from Revision K (July 2014) to Revision L	Page
• Updated Power-On/Reset Timing Diagram options	18

Changes from Revision J (May 2014) to Revision K	Page
• Updated pin description for ENABLE	4
• Updated pin voltages in <i>Absolute Maximum Ratings</i>	6
• Added more information to <i>Power-On Reset</i> detailing two power-on/reset timing options	18
• Added Figure 13	19

Changes from Revision I (January 2014) to Revision J	Page
• Changed format to meet latest data sheet standards; added new sections and moved existing sections	1
• Changed Description	3
• Changed paragraph for LCKREFN in <i>Description (continued)</i>	3
• Changed Description of LCKREFN in	4
• Changed <i>Power-On Reset</i> section	17

Changes from Revision H (December 2013) to Revision I	Page
• Added /EM bullet to <i>Features</i>	1
• Deleted Ordering Information table	12

5 Description (continued)

This device can also be used to replace parallel data transmission architectures by providing a reduction in the number of traces, connector pins, and transmit/receive pins. Parallel data loaded into the transmitter is delivered to the receiver over a serial channel, which can be a coaxial copper cable, a controlled impedance backplane, or an optical link. It is then reconstructed into its original parallel format. It offers significant power and cost savings over parallel solutions, as well as scalability for higher data rates in the future.

The TLK2711-SP performs parallel-to-serial and serial-to-parallel data conversion. The clock extraction functions as a physical layer (PHY) interface device. The serial transceiver interface operates at a maximum speed of 2.5 Gbps. The transmitter latches 16-bit parallel data at a rate based on the supplied reference clock (TXCLK). The 16-bit parallel data is internally encoded into 20 bits using an 8-bit/10-bit (8b/10b) encoding format. The resulting 20-bit word is then transmitted differentially at 20× the reference clock (TXCLK) rate. The receiver section performs the serial-to-parallel conversion on the input data, synchronizing the resulting 20-bit wide parallel data to the recovered clock (RXCLK). It then decodes the 20-bit wide data using the 8-bit/10-bit decoding format resulting in 16 bits of parallel data at the receive data pins (RXD0–RXD15). The outcome is an effective data payload of 1.28 to 2 Gbps (16 bits data × the frequency).

The TLK2711-SP is available in a 68-pin ceramic nonconductive tie-bar package (HFG).

NOTE

The errata noted in the commercial TLK2711 device titled *Errata to the TLK2711, 1.6-to-2.7 GBPS Transceiver Data Sheet– PLL False Lock Problem* does not apply to the TLK2711-SP device. The TLK2711-SP is functionally equivalent to the TLK2711A commercial device.

The TLK2711-SP provides an internal loopback capability for self-test purposes. Serial data from the serializer is passed directly to the deserializer, providing the protocol device with a functional self-check of the physical interface.

The TLK2711-SP has a LOS detection circuit for conditions where the incoming signal no longer has a sufficient voltage amplitude to keep the clock recovery circuit in lock.

The TLK2711-SP allows users to implement redundant ports by connecting receive data bus pins from two TLK2711-SP devices together. Asserting the LCKREFN to a low state causes the receive data bus pins (RXD0 - RXD15, RXCLK, RKLSB, and RKMSB) to go to a high-impedance state if device is enabled (ENABLE = H). This places the device in a transmit-only mode, because the receiver is not tracking the data. LCKREFN must be de-asserted to a high state during power-on reset (see [Power-On Reset](#)). If the device is disabled (ENABLE = L), then RKMSB will output the status of the LOS detector (active low = LOS). All other receive outputs will remain high-impedance.

The TLK2711-SP I/Os are 3-V compatible. The TLK2711-SP is characterized for operation from –55°C to 125°C T_{case} .

The TLK2711-SP is designed to be hot-plug capable. An on-chip power-on reset circuit holds the RXCLK low, and goes to high impedance on the parallel-side output signal pins, as well as TXP and TXN during power up.

6 Pin Configuration and Functions

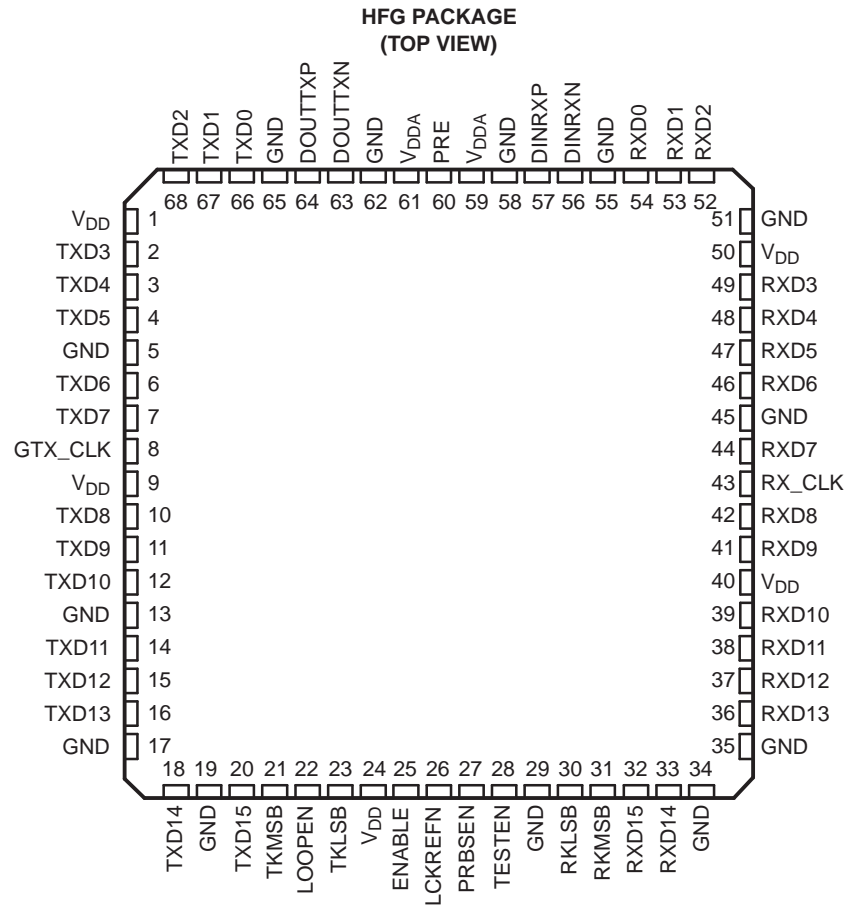

Pin Functions

PIN		I/O	DESCRIPTION
NAME	NO.		
DOUPTXN DOUPTXP	63 64	O	Serial transmit outputs. TXP and TXN are differential serial outputs that interface to copper or an optical I/F module. These pins transmit NRZ data at a rate of 20x the TXCLK value. TXP and TXN are put in a high-impedance state when LOOPEN is high and are active when LOOPEN is low. During power-on reset, these pins are high impedance.
ENABLE	25	I ⁽¹⁾	Device enable. When this pin is held low, the device is placed in power-down mode. Only the signal detect circuit on the serial receive pair is active. When in power-down mode, RKMSB will output the status of signal detect circuit (LOS). When asserted high while the device is in power-down mode, the transceiver is reset before beginning normal operation.
GND	5, 13, 17, 19, 29, 34, 35, 45, 51, 55, 58, 62, 65	—	Analog and digital logic ground. Provides a ground for the logic circuits, digital I/O buffers, and the high-speed analog circuits.
LCKREFN	26	I ⁽¹⁾	Lock to reference. When LCKREFN is low, the receiver clock is frequency locked to TXCLK. This places the device in a transmit-only mode since the receiver is not tracking the data. When LCKREFN is asserted low, the receive data bus pins (RXD0 through RXD15, RXCLK, RKLSB, and RKMSB) are in a high-impedance state if device is enabled (ENABLE = H). If device is disabled (ENABLE = L), then RKMSB will output the status of the LOS detector (active low = LOS). All other receive outputs will remain high-impedance. When LCKREFN is deasserted high, the receiver is locked to the received data stream. LCKREFN must be deasserted to a high state during power-on reset. See Power-On Reset .

(1) Internal 10-kΩ pullup

Pin Functions (continued)

PIN		I/O	DESCRIPTION
NAME	NO.		
LOOPEN	22	I ⁽²⁾	Loop enable. When LOOPEN is active high, the internal loopback path is activated. The transmitted serial data is directly routed internally to the inputs of the receiver. This provides a self-test capability in conjunction with the protocol device. The TXP and TXN outputs are held in a high-impedance state during the loopback test. LOOPEN is held low during standard operational state, with external serial outputs and inputs active.
PRE	60	I ⁽²⁾	Preemphasis control. Selects the amount of preemphasis to be added to the high-speed serial output drivers. Left low or unconnected, 5% preemphasis is added. Pulled high, 20% preemphasis is added.
PRBSEN	27	I ⁽²⁾	PRBS test enable. When asserted high, results of pseudo-random bit stream (PRBS) tests can be monitored on the RKLSB pin. A high on RKLSB indicates that valid PRBS is being received.
RKLSB	30	O	K-code indicator/PRBS test results. When RKLSB is asserted high, an 8-bit/10-bit K code was received and is indicated by data bits RXD0 through RXD7. When RKLSB is asserted low, an 8-bit/10-bit D code is received and is presented on data bits RXD0 through RXD7. When PRBSEN is asserted high, this pin is used to indicate status of the PRBS test results (high = pass).
RKMSB	31	O	K-code indicator. When RKMSB is asserted high an 8-bit/10-bit K code was received and is indicated by data bits RXD8 through RXD15. When RKMSB is asserted low an 8-bit/10-bit D code was received and is presented on data bits RXD8 through RXD15. If the differential signal on RXN and RXP drops below 200 mV, RXD0–RXD15, RKLSB, and RKMSB are all asserted high. When device is disabled (ENABLE = L), RKMSB will output the status of LOS. Active low = LOS detected.
RXCLK RX_CLK	43	O	Recovered clock. Output clock that is synchronized to RXD0 through RXD9, RKLSB, and RKMSB. RXCLK is the recovered serial data rate clock divided by 20. RXCLK is held low during power-on reset.
RXD0 RXD1 RXD2 RXD3 RXD4 RXD5 RXD6 RXD7 RXD8 RXD9 RXD10 RXD11 RXD12 RXD13 RXD14 RXD15	54 53 52 49 48 47 46 44 42 41 39 38 37 36 33 32	O	Receive data bus. These outputs carry 16-bit parallel data output from the transceiver to the protocol device, synchronized to RXCLK. The data is valid on the rising edge of RXCLK as shown in Figure 10 . These pins are in high-impedance state during power-on reset.
DINRXN DINRXP	56 57	I	Serial receive inputs. RXP and RXN together are the differential serial input interface from a copper or an optical I/F module.
TESTEN	28	I ⁽²⁾	Test mode enable. This pin should be left unconnected or tied low.
TKLSB	23	I ⁽³⁾	K-code generator (LSB). When TKLSB is high, an 8-bit/10-bit K code is transmitted as controlled by data bits TXD0 through TXD7. When TKLSB is low, an 8-bit/10-bit D code is transmitted as controlled by data bits TXD0 through TXD7.
TKMSB	21	I ⁽³⁾	K-code generator (MSB). When TKMSB is high, an 8-bit/10-bit K code is transmitted as controlled by data bits TXD8 through TXD15. When TKMSB is low, an 8-bit/10-bit D code is transmitted as controlled by data bits TXD8 through TXD15.
TXCLK GTX_CLK	8	I	Reference clock. TXCLK is a continuous external input clock that synchronizes the transmitter interface signals TKMSB, TKLSB, and TXD0–TXD15. The frequency range of TXCLK is 80 to 135 MHz. The transmitter uses the rising edge of this clock to register the 16-bit input data TXD0 through TXD15 for serialization.

(2) Internal 10-kΩ pulldown

(3) Internal 10-kΩ pullup

Pin Functions (continued)

PIN		I/O	DESCRIPTION
NAME	NO.		
TXD0	66	I	Transmit data bus. These inputs carry the 16-bit parallel data output from a protocol device to the transceiver for encoding, serialization, and transmission. This 16-bit parallel data is clocked into the transceiver on the rising edge of TXCLK as shown in Figure 7 .
TXD1	67		
TXD2	68		
TXD3	2		
TXD4	3		
TXD5	4		
TXD6	6		
TXD7	7		
TXD8	10		
TXD9	11		
TXD10	12		
TXD11	14		
TXD12	15		
TXD13	16		
TXD14	18		
TXD15	20		
VDD	1, 9, 24, 40, 50		Digital logic power. Provides power for all digital circuitry and digital I/O buffers.
VDDA	59, 61		Analog power. VDDA provides a supply reference for the high-speed analog circuits, receiver, and transmitter.

7 Specifications

7.1 Absolute Maximum Ratings

 over operating temperature (unless otherwise noted)⁽¹⁾

		MIN	MAX	UNIT
V _{DD}	Supply voltage ⁽²⁾	-0.3	3	V
Voltage	TXD0 to TXD15, ENABLE, TXCLK, TKMSB, TKLSB, LOOPEN, PRBSEN, LCKREFN, PRE, TESTEN	-0.3	4	V
	RXD0 to RXD15, RKMSB, RKLSB, RXCLK	-0.3	V _{DD} + 0.35	V
	DINRXP, DINRXN, DOUETXP, DOUETXN	-0.35	V _{DDA} + 0.35	V
T _c	Characterized case operating temperature	-55	125	°C
	Maximum cumulative exposure of unpowered receiver to external inputs ⁽³⁾		10	hours

- (1) Stresses beyond those listed under *Absolute Maximum Ratings* may cause permanent damage to the device. These are stress ratings only, and functional operation of the device at these or any other conditions beyond those indicated under *Recommended Operating Conditions* is not implied. Exposure to absolute-maximum-rated conditions for extended periods may affect device reliability.
- (2) All voltage values, except differential I/O bus voltages, are stated with respect to network ground.
- (3) The TLK2711-SP shows no performance degradation when an external powered transmitter sends a signal to an unpowered receiver for short periods of time (up to 10 hours of lifetime of the device). Characterization was performed using maximum V_{OD}, minimum frequency and typical V_{CM} from recommended operating conditions for the specified period of time.

7.2 Handling Ratings

		MIN	MAX	UNIT	
T _{stg}	Storage temperature range	-65	150	°C	
V _(ESD)	Electrostatic discharge	Human body model (HBM), per ANSI/ESDA/JEDEC JS-001, all pins ⁽¹⁾	-2000	2000	V

- (1) JEDEC document JEP155 states that 500-V HBM allows safe manufacturing with a standard ESD control process.

7.3 Recommended Operating Conditions

over operating free-air temperature range (unless otherwise noted)

			MIN	NOM	MAX	UNIT	
V _{DD}	Supply voltage	Frequency range 1.6 Gbps to 2 Gbps	2.375	2.5	2.625	V	
		Frequency range 1.6 Gbps to 2.5 Gbps	2.5	2.6	2.7		
I _{CC}	Supply current	Frequency = 1.6 Gbps, PRBS pattern	110			mA	
		Frequency = 2.5 Gbps, PRBS pattern	160				
P _D	Power dissipation	Frequency = 1.6 Gbps, PRBS pattern	275			mW	
		Frequency = 2.5 Gbps, PRBS pattern	400				
		Frequency = 2.5 Gbps, PRBS pattern	550				
	Shutdown current	Enable = 0, V _{DDA} , V _{DD} pins, V _{DD} = MAX	3			mA	
	PLL startup lock time	V _{DD} , V _{DDC} = 2.375 V	0.1			0.4	ms
	Data acquisition time		1024			bits	
T _c	Operating case temperature		-55		125	°C	

7.4 Thermal Information⁽¹⁾

THERMAL METRIC ⁽²⁾		TLK2711-SP	UNIT
		HFG	
		68 PINS	
R _{θJA}	Junction-to-ambient thermal resistance	31.5	°C/W
R _{θJC}	Junction-to-case thermal resistance	2.96	

- (1) This CFP package has built-in vias that electrically and thermally connect the bottom of the die to a pad on the bottom of the package. To efficiently remove heat and provide a low-impedance ground path, a thermal land is required on the surface of the PCB directly underneath the body of the package. During normal surface mount flow solder operations, the heat pad on the underside of the package is soldered to this thermal land creating an efficient thermal path. Normally, the PCB thermal land has a number of thermal vias within it that provide a thermal path to internal copper areas (or to the opposite side of the PCB) that provide for more efficient heat removal. TI typically recommends an 11.9-mm × 11.9-mm board-mount thermal pad with a 4.2-mm × 4.2-mm solder mask defined pad attach opening. This allows maximum area for thermal dissipation, while allowing leads pad to solder pad clearance. A sufficient quantity of thermal or electrical vias must be included to keep the device within *Recommended Operating Conditions*. This pad must be electrically ground potential.
- (2) For more information about traditional and new thermal metrics, see the *IC Package Thermal Metrics* application report, [SPRA953](#).

7.5 TTL Input Electrical Characteristics

over recommended operating conditions (unless otherwise noted),

TTL signals: TXD0–TXD15, TXCLK, LOOPEN, LCKREFN, ENABLE, PRBS_EN, TKLSB, TKMSB, PRE

PARAMETER	TEST CONDITIONS	MIN	TYP	MAX	UNIT	
V _{IH}	High-level input voltage	See Figure 1			V	
V _{IL}	Low-level input voltage	See Figure 1			0.8	V
I _{IH}	Input high current	V _{DD} = MAX, V _{IN} = 2 V			40	μA
I _{IL}	Input low current	V _{DD} = MAX, V _{IN} = 0.4 V			-40	μA
C _I	Receiver input capacitance				6	pF
t _r	Rise time, TXCLK, TKMSB, TKLSB, TXD0 to TXD15	0.7 to 1.9 V, C = 5 pF, See Figure 1			1	ns
t _f	Fall time, TXCLK, TKMSB, TKLSB, TXD0 to TXD15	1.9 to 0.7 V, C = 5 pF, See Figure 1			1	ns
t _{su}	TXD0 to TXD15, TKMSB, TKLSB setup to ↑ TXCLK	See Figure 1 ⁽¹⁾			1.5	ns
t _h	TXD, TKMSB, TKLSB hold to ↑ TXCLKS	See Figure 1 ⁽¹⁾			0.4	ns

- (1) Nonproduction tested parameters

7.6 Transmitter/Receiver Electrical Characteristics

PARAMETER		TEST CONDITIONS	MIN	TYP	MAX	UNIT
$V_{OD(p)}$	Preemphasis VOD, direct, $V_{OD(p)} = VTXP - VTXN $	$R_t = 50 \Omega$, PREM = high, DC coupled, See Figure 3	655	800	1100	mV
		$R_t = 50 \Omega$, PREM = low, DC coupled, See Figure 3	590	740	1050	
$V_{OD(pp,p)}$	Differential, peak-to-peak output voltage with preemphasis	$R_t = 50 \Omega$, PREM = high, DC coupled, See Figure 3	1310	1600	2200	mV _{pp}
		$R_t = 50 \Omega$, PREM = low, DC coupled, See Figure 3	1180	1480	2100	
$V_{OD(d)}$	Deemphasis output voltage, $ VTXP - VTXN $	$R_t = 50 \Omega$, DC coupled, See Figure 3	540	650	950	mV
$V_{OD(pp,d)}$	Differential, peak-to-peak output voltage with deemphasis	$R_t = 50 \Omega$, DC coupled, See Figure 3	1080	1300	1900	mV _{pp}
$V_{(cm)}$	Transmit common mode voltage range, $(VTXP + VTXN) / 2$	$R_t = 50 \Omega$, See Figure 3	1000	1250	1450	mV
V_{ID}	Receiver input voltage differential, $ VRXP - VRXN $	See ⁽¹⁾	220		1600	mV
$V_{(cmr)}$	Receiver common mode voltage range, $(VRXP + VRXN) / 2$	See ⁽¹⁾	1000	1250	2250	mV
I_{ikg}	Receiver input leakage current		-10		10	μ A
C_i	Receiver input capacitance			4		pF
	Serial data total jitter (peak to peak)	Differential output jitter at 2.5 Gbps, Random + deterministic, PRBS pattern		0.28		UI ⁽²⁾
		Differential output jitter at 1.6 Gbps, Random + deterministic, PRBS pattern		0.32		
t_r, t_f	Differential output signal rise, fall time (20% to 80%)	$R_L = 50 \Omega$, $C_L = 5$ pF, See Figure 3		150		ps
	Jitter tolerance eye closure	Differential input jitter, random + deterministic, PRBS pattern at zero crossing ⁽³⁾	0.4			UI
$t_{d(Tx \text{ latency})}$	Tx latency	See Figure 8	34		38	bits
$t_{d(Rx \text{ latency})}$	Rx latency	See Figure 11	76		107	bits

- (1) Nonproduction tested parameters
 (2) UI is the time interval of one serialized bit.
 (3) Nonproduction tested parameters

7.7 Reference Clock (TXCLK) Timing Requirements

over recommended operating conditions (unless otherwise noted)

PARAMETER	TEST CONDITIONS	MIN	TYP	MAX	UNIT
Frequency	Receiver data rate / 20	-100		100	ppm
Frequency tolerance		-100		100	ppm
Duty cycle		40%	50%	60%	
Jitter	Peak to peak			40	ps

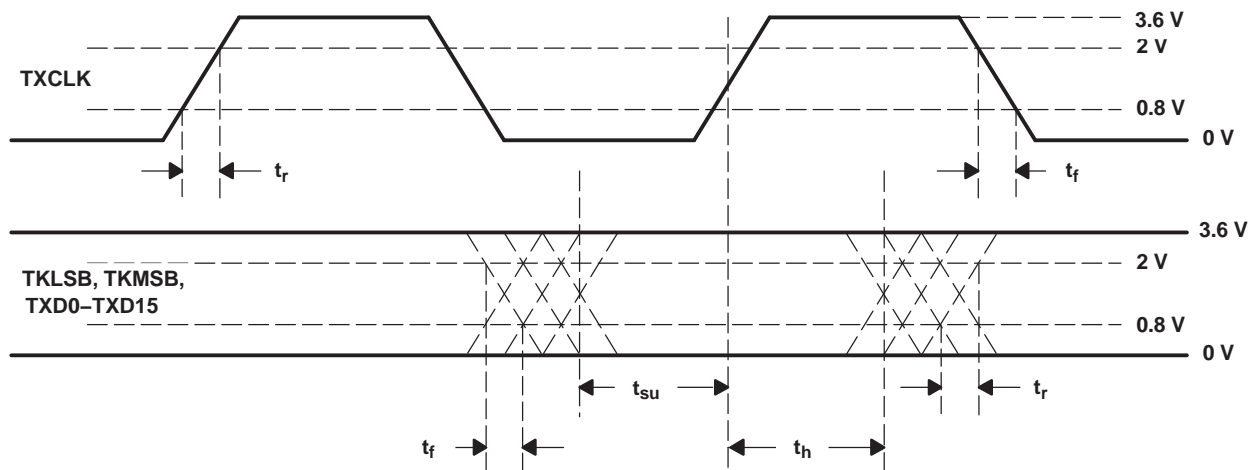

Figure 1. TTL Data Input Valid Levels for AC Measurements

7.8 TTL Output Switching Characteristics

over recommended operating conditions (unless otherwise noted)

PARAMETER	TEST CONDITIONS	MIN	TYP	MAX	UNIT
V_{OH} High-level output voltage	$I_{OH} = -2\text{ mA}$, $V_{DD} = \text{MIN}$	2.1	2.3		V
V_{OL} Low-level output voltage	$I_{OL} = 2\text{ mA}$, $V_{DD} = \text{MIN}$		0.25	0.5	V
$t_{r(\text{slew})}$ Slew rate (rising), magnitude of RXCLK, RKLSB, RKMSB, RXD0 to RXD15	0.8 V to 2 V, $C = 5\text{ pF}$, See Figure 2	0.5			V/ns
$t_{f(\text{slew})}$ Slew rate (falling), magnitude of RXCLK, RKLSB, RKMSB, RXD0 to RXD15	0.8 V to 2 V, $C = 5\text{ pF}$, See Figure 2	0.5			V/ns
t_{su} RXD0 to RXD15, RKMSB, RKLSB setup to \uparrow RXCLK	50% voltage swing, TXCLK = 80 MHz, See Figure 2 ⁽¹⁾	3			ns
	50% voltage swing, TXCLK = 125 MHz, See Figure 2 ⁽¹⁾	2.5			
t_h RXD0 to RXD15, RKMSB, RKLSB hold to \uparrow RXCLK	50% voltage swing, TXCLK = 80 MHz, See Figure 2 ⁽¹⁾	3			ns
	50% voltage swing, TXCLK = 125 MHz, See Figure 2 ⁽¹⁾	2			

(1) Nonproduction tested parameters

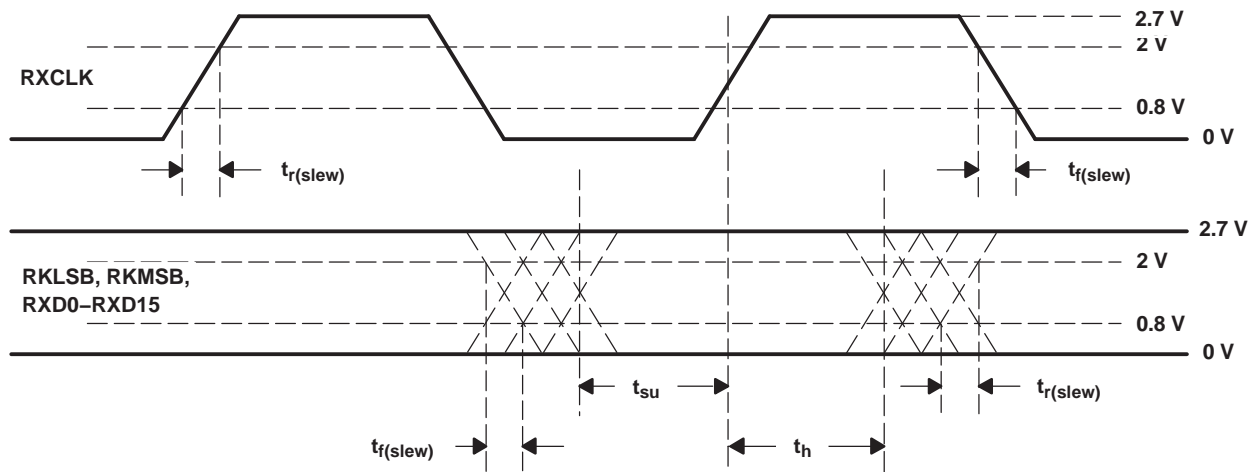
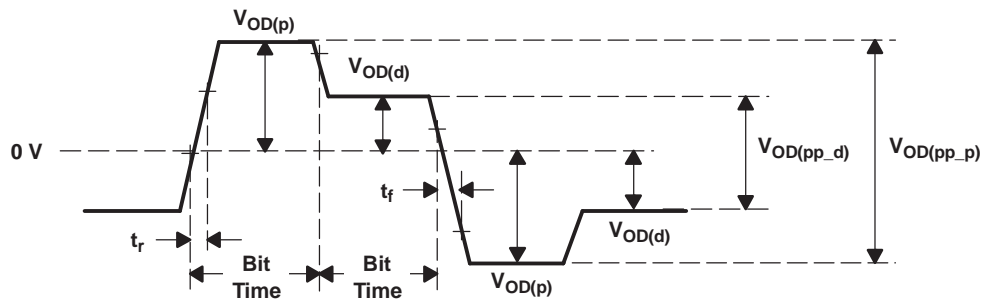
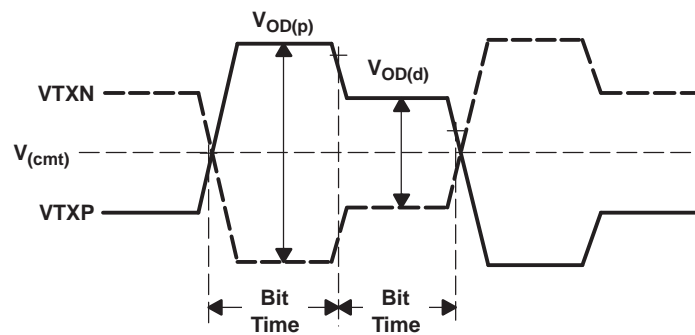
Figure 2. TTL Data Output Valid Levels for AC Measurements

Figure 3. Differential and Common-Mode Output Voltage

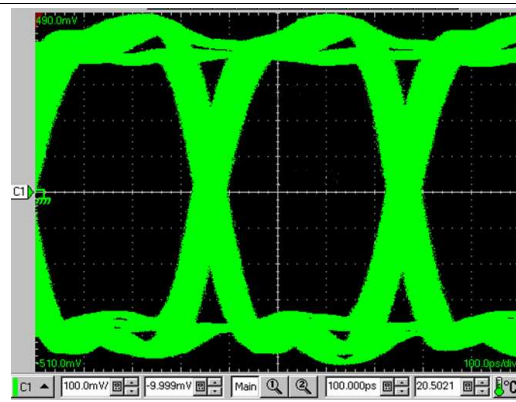
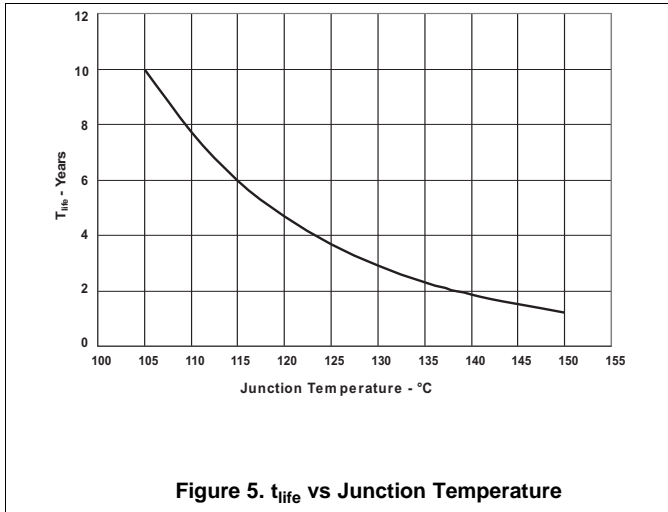
Figure 4. Common-Mode Output Voltage Definitions

7.9 Typical Characteristics



8 Detailed Description

8.1 Overview

The TLK2711-SP is a member of the WizardLink transceiver family of multigigabit transceivers, intended for use in ultra-high-speed bidirectional point-to-point data transmission systems. The TLK2711-SP supports an effective serial interface speed of 1.6 Gbps to 2.5 Gbps, providing up to 2 Gbps of data bandwidth.

The following sections describe block-by-block features and operation of the TLK2711-SP transceiver.

8.2 Functional Block Diagram

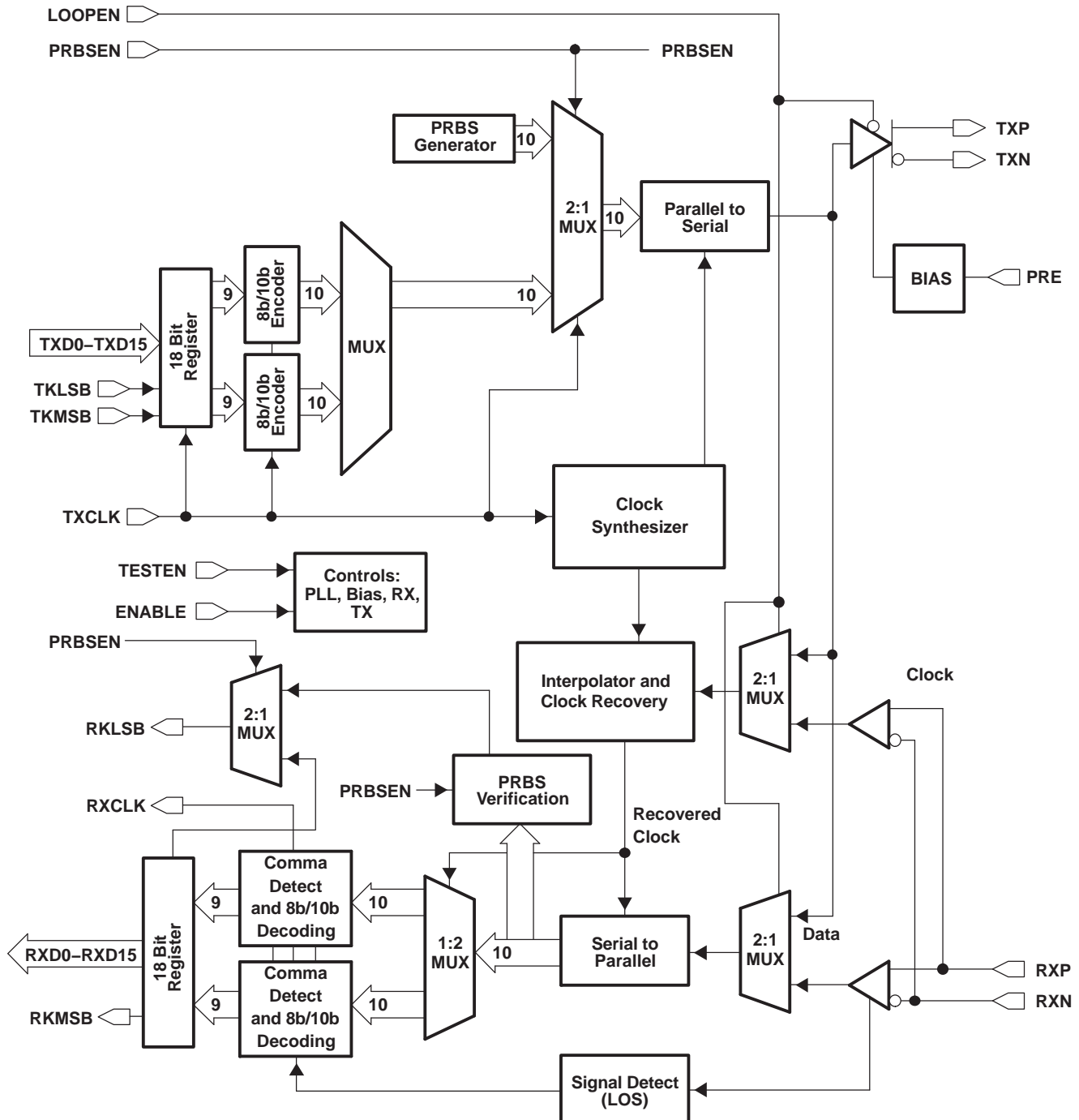

8.3 Feature Description

8.3.1 Transmit Interface

The transmitter interface registers valid incoming 16-bit-wide data (TXD0 to TXD15) on the rising edge of the TXCLK. The data is then 8-bit/10-bit encoded, serialized, and transmitted sequentially over the differential high-speed I/O channel. The clock multiplier multiplies the reference clock (TXCLK) by a factor of 10x, creating a bit clock. This internal bit clock is fed to the parallel-to-serial shift register, which transmits data on both the rising and falling edges of the bit clock, providing a serial data rate that is 20x the reference clock. Data is transmitted least significant bit (LSB) (TXD0) first.

8.3.2 Transmit Data Bus

The transmit data bus interface accepts 16-bit single-ended TTL parallel data at the TXD0–TXD15 pins. Data and K-code control is valid on the rising edge of the TXCLK. The TXCLK is used as the word clock. The data, K-code, and clock signals must be properly aligned as shown in Figure 7. Detailed timing information can be found in the *Transmitter/Receiver Electrical Characteristics*.

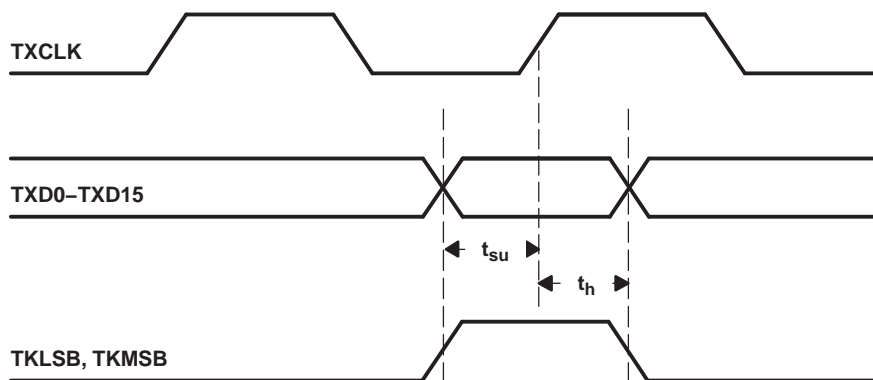

Figure 7. Transmit Timing Waveform

8.3.3 Data Transmission Latency

The data transmission latency of the TLK2711-SP is defined as the delay from the initial 16-bit word load to the serial transmission of bit 0. The transmit latency is fixed after the link is established. However, due to silicon process variations and implementation variables such as supply voltage and temperature, the exact delay varies slightly. The minimum transmit latency $t_{d(Tx \text{ latency})}$ is 34 bit times; the maximum is 38 bit times. Figure 8 shows the timing relationship between the transmit data bus, TXCLK, and serial transmit pins.

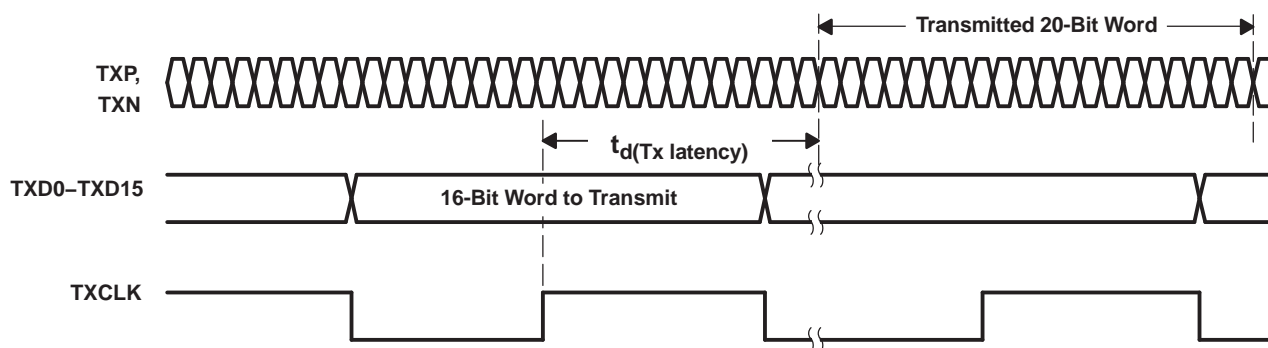

Figure 8. Transmitter Latency

Feature Description (continued)

8.3.4 8-Bit/10-Bit Encoder

All true serial interfaces require a method of encoding to ensure minimum transition density, so that the receiving phase-locked loop (PLL) has a minimal number of transitions to stay locked on. The encoding scheme maintains the signal DC balance by keeping the number of 1s and 0s the same. This provides good transition density for clock recovery and improves error checking. The TLK2711-SP uses the 8-bit/10-bit encoding algorithm that is used by fibre channel and gigabit ethernet. This is transparent to the user, as the TLK2711-SP internally encodes and decodes the data such that the user reads and writes actual 16-bit data.

The 8-bit/10-bit encoder converts 8-bit-wide data to a 10-bit-wide encoded data character to improve its transmission characteristics. Because the TLK2711-SP is a 16-bit-wide interface, the data is split into two 8-bit-wide bytes for encoding. Each byte is fed into a separate encoder. The encoding is dependent upon two additional input signals, TKMSB and TKLSB.

Table 1. Transmit Data Controls

TKLSB	TKMSB	16 BIT PARALLEL INPUT	
0	0	Valid data on TXD0 to TXD7	Valid data TXD8 to TXD15
0	1	Valid data on TXD0 to TXD7	K code on TXD8 to TXD15
1	0	K code on TXD0 to TXD7	Valid data on TXD8 to TXD15
1	1	K code on TXD0 to TXD7	K code on TXD8 to TXD15

8.3.5 Pseudo-Random Bit Stream (PRBS) Generator

The TLK2711-SP has a built-in $2^7 - 1$ PRBS function. When the PRBSEN pin is forced high, the PRBS test is enabled. A PRBS is generated and fed into the 10-bit parallel-to-serial converter input register. Data from the normal input source is ignored during the PRBS mode. The PRBS pattern is then fed through the transmit circuitry as if it were normal data and sent out to the transmitter. The output can be sent to a bit error rate tester (BERT), the receiver of another TLK2711-SP, or looped back to the receive input. Because the PRBS is not really random, but a predetermined sequence of 1s and 0s, the data can be captured and checked for errors by a BERT.

8.3.6 Parallel to Serial

The parallel-to-serial shift register takes in the 20-bit-wide data word multiplexed from the two parallel 8-bit/10-bit encoders and converts it to a serial stream. The shift register is clocked on both the rising and falling edge of the internally generated bit clock, which is 10x the TXCLK input frequency. The LSB (TXD0) is transmitted first.

8.3.7 High-Speed Data Output

The high-speed data output driver consists of a voltage mode logic (VML) differential pair optimized for a 50-Ω impedance environment. The magnitude of the differential-pair signal swing is compatible with pseudo emitter coupled logic (PECL) levels when AC coupled. The line can be directly coupled or AC coupled. See [Figure 14](#) and [Figure 15](#) for termination details. The outputs also provide preemphasis to compensate for AC loss when driving a cable or PCB backplane trace over a long distance (see [Figure 9](#)). The level of preemphasis is controlled by PRE (see [Table 2](#)).

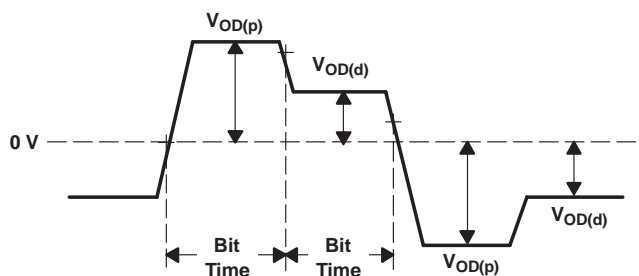
Figure 9. Output Voltage Under Preemphasis (V_{TXP} to V_{TXN})
Table 2. Programmable Preemphasis

PRE	PREEMPHASIS LEVEL (%) V _{OD(P)} , V _{OD(D)} ⁽¹⁾
0	5%
1	20%

- (1) V_{OD(p)}: Voltage swing when there is a transition in the data stream.
V_{OD(d)}: Voltage swing when there is no transition in the data stream.

8.3.8 Receive Interface

The receiver interface of the TLK2711-SP accepts 8-bit/10-bit encoded differential serial data. The interpolator and clock recovery circuit locks to the data stream and extracts the bit-rate clock. This recovered clock is used to retiming the input data stream. The serial data is then aligned to two separate 10-bit word boundaries, 8-bit/10-bit decoded, and output on a 16-bit-wide parallel bus synchronized to the extracted receive clock. The data is received LSB (RXD0) first.

8.3.9 Receive Data Bus

The receive bus interface drives 16-bit-wide single-ended TTL parallel data at the RXD0 to RXD15 pins. Data is valid on the rising edge of the RXCLK. The RXCLK is used as the recovered word clock. The data, RKLSB, RKMSB, and clock signals are aligned as shown in Figure 10. Detailed timing information can be found in the [TTL Output Switching Characteristics](#).

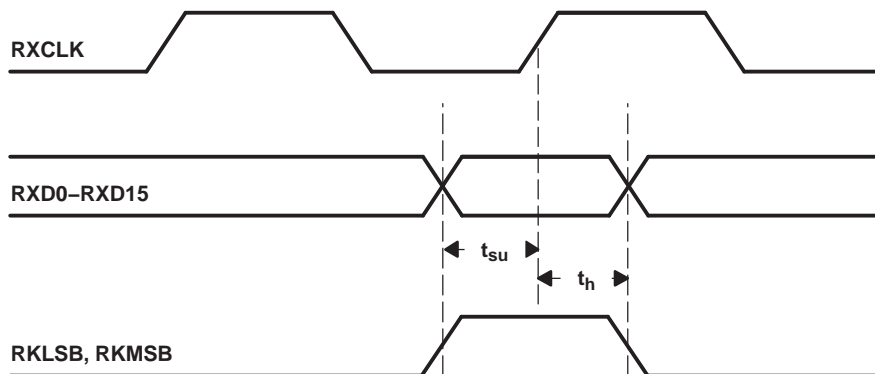

Figure 10. Receive Timing Waveform

8.3.10 Data Reception Latency

The serial-to-parallel data receive latency is the time from when the first bit arrives at the receiver until it is output in the aligned parallel word. The receive latency is fixed after the link is established. However, due to silicon process variations and implementation variables such as supply voltage and temperature, the exact delay varies slightly. The minimum receive latency $t_{d(Rx \text{ latency})}$ is 76 bit times; the maximum is 107 bit times. Figure 11 shows the timing relationship between the serial receive pins, the recovered word clock (RXCLK), and the receive data bus.

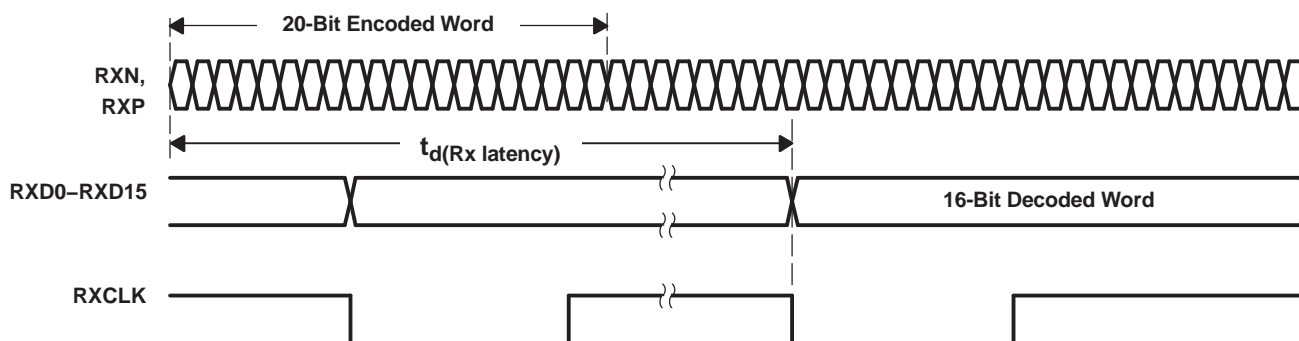

Figure 11. Receiver Latency

8.3.11 Serial to Parallel

Serial data is received on the RXP and RXN pins. The interpolator and clock recovery circuit locks to the data stream if the clock to be recovered is within 200 PPM of the internally generated bit rate clock. The recovered clock is used to retiming the input data stream. The serial data is then clocked into the serial-to-parallel shift registers. The 10-bit-wide parallel data is then multiplexed and fed into two separate 8-bit/10-bit decoders, where the data is then synchronized to the incoming data stream word boundary by detection of the comma 8-bit/10-bit synchronization pattern.

8.3.12 Comma Detect and 8-Bit/10-Bit Decoding

The TLK2711-SP has two parallel 8-bit/10-bit decode circuits. Each 8-bit/10-bit decoder converts 10-bit encoded data (half of the 20-bit received word) back into 8 bits. The comma-detect circuit is designed to provide for byte synchronization to an 8-bit/10-bit transmission code. When parallel data is clocked into a parallel-to-serial converter, the byte boundary that was associated with the parallel data is now lost in the serialization of the data. When the serial data is received and converted to parallel format again, a method is needed to recognize the byte boundary. Typically, this is accomplished through the use of a synchronization pattern. This is typically a unique pattern of 1s and 0s that either cannot occur as part of valid data or is a pattern that repeats at defined intervals. The 8-bit/10-bit encoding contains a character called the comma (b0011111 or b1100000), which is used by the comma-detect circuit on the TLK2711-SP to align the received serial data back to its original byte boundary. The decoder detects the comma, generating a synchronization signal aligning the data to their 10-bit boundaries for decoding; the comma is mapped into the LSB. The decoder then converts the data back into 8-bit data. The output from the two decoders is latched into the 16-bit register synchronized to the recovered parallel data clock (RXCLK) and output valid on the rising edge of the RXCLK.

NOTE

The TLK2711-SP only achieves byte alignment on the 0011111 comma.

Decoding provides two additional status signals, RKLSB and RKMSB. When RKLSB is asserted, an 8-bit/10-bit K code is received and the specific K code is presented on the data bits RXD0 to RXD7; otherwise, an 8-bit/10-bit D code is received. When RKMSB is asserted, an 8-bit/10-bit K code is received and the specific K-code is presented on data bits RXD8 to RXD15; otherwise, an 8-bit/10-bit D code is received (see [Table 3](#)). The valid K codes the TLK2711-SP; decodes are provided in [Table 4](#). An error detected on either byte, including K codes not in [Table 4](#), causes that byte only to indicate a K0.0 code on the RKxSB and associated data pins, where K0.0 is known to be an invalid 8-bit/10-bit code. A loss of input signal causes a K31.7 code to be presented on both bytes, where K31.7 is also known to be an invalid 8-bit/10-bit code.

Table 3. Receive Status Signals

RKLSB	RKMSB	DECODED 20-BIT OUTPUT	
0	0	Valid data on RXD0 to RXD7	Valid data RXD8 to RXD15
0	1	Valid data on RXD0 to RXD7	K code on RXD8 to RXD15
1	0	K code on RXD0 to RXD7	Valid data on RXD8 to RXD15
1	1	K code on RXD0 to RXD7	K code on RXD8 to RXD15

Table 4. Valid K Characters

K CHARACTER	RECEIVE DATA BUS RXD0 to RXD7 OR RXD8 to RXD15
K28.0	000 11100
K28.1 ⁽¹⁾	001 11100
K28.2	010 11100
K28.3	011 11100
K28.4	100 11100
K28.5 ⁽¹⁾	101 11100
K28.6	110 11100
K28.7 ⁽¹⁾	111 11100
K23.7	111 10111
K27.7	111 11011
K29.7	111 11101
K30.7	111 11110

(1) Should only be present on RXD0 to RXD7 when in running disparity <0

8.3.13 LOS Detection

The TLK2711-SP has a LOS detection circuit for conditions where the incoming signal no longer has a sufficient voltage level to keep the clock recovery circuit in lock. The signal detection circuit is intended to be an indication of gross signal error conditions, such as a detached cable or no signal being transmitted, and not an indication of signal coding health. The TLK2711-SP reports this condition by asserting RKLSB, RKMSB, and RXD0 to RXD15 pins to a high state. As long as the differential signal is above 200 mV in differential magnitude, the LOS circuit does not signal an error condition. When the device is disabled (ENABLE = L), RKMSB will output the status of LOS. Active low = LOS detected.

8.3.14 PRBS Verification

The TLK2711-SP also has a built-in BERT function in the receiver side that is enabled by the PRBSEN. It can check for errors and report the errors by forcing the RKLSB pin low.

8.3.15 Reference Clock Input

The reference clock (TXCLK) is an external input clock that synchronizes the transmitter interface. The reference clock is then multiplied in frequency 10x to produce the internal serialization bit clock. The internal serialization bit clock is frequency locked to the reference clock and used to clock out the serial transmit data on both its rising and falling edges, providing a serial data rate that is 20x the reference clock.

8.3.16 Operating Frequency Range

The TLK2711-SP operates at a serial data rate from 1.6 to 2.5 Gbps. To achieve these serial rates, TXCLK must be within 80 to 125 MHz. The TXCLK must be within ± 100 PPM of the desired parallel data rate clock.

8.3.17 Testability

The TLK2711-SP has a comprehensive suite of built-in self-tests. The loopback function provides for at-speed testing of the transmit/receive portions of the circuitry. The enable pin allows for all circuitry to be disabled so that a quiescent current test can be performed. The PRBS function allows for built-in self-test (BIST).

8.3.18 Loopback Testing

The transceiver can provide a self-test function by enabling (LOOPEN) the internal loopback path. Enabling this pin causes serial-transmitted data to be routed internally to the receiver. The parallel data output can be compared to the parallel input data for functional verification. The external differential output is held in a high-impedance state during the loopback testing.

8.3.19 BIST

The TLK2711-SP has a BIST function. By combining PRBS with loopback, an effective self-test of all the circuitry running at full speed can be realized. The successful completion of the BIST is reported on the RKLSB pin.

8.3.20 Power-On Reset

Upon application of minimum valid power and valid GTX_CLK with device enabled (ENABLE = HIGH), the TLK2711-SP generates a power-on reset. During the power-on reset the RXD0 to RXD15, RKLSB, and RKMSB signal pins go to a high-impedance state. The RXCLK is held low. LCKREFN must be deasserted (logic high state) with active transitions on the receiver during the power-on reset period. Active transitions on receiver can be accomplished with transitions on RXP/N or by assertion of LOOPEN. For TX-only applications, LOOPEN and LCKREFN can be driven logic high together. The receiver circuit requires this to properly reset. After power-up reset period, LCKREFN can be asserted for transmit only applications. The length of the power-on reset cycle depends on the TXCLK frequency, but is less than 1 ms. See [Figure 12](#) for power up option 1. Option 1 shows timing requirements when ENABLE = HIGH at power up. See [Figure 13](#) for power up option 2. Option 2 resets the receiver circuit immediately at power up without enabling complete device with ENABLE = LOW. The complete reset of device occurs after ENABLE is asserted HIGH. LCKREFN does not need to continue to be logic high after the initial 1-ms reset period. TI recommends that the receiver be reset immediately after power up using options 1 or 2. In some conditions, it is possible for the receiver circuit to power up in state with internal contention.

If LCKREFN cannot be deasserted high during or for the complete power-on reset period, it can be deasserted high at the end of or after the power-on reset period for minimum of 1 μ S with active transitions on receiver to properly complete reset of receiver.

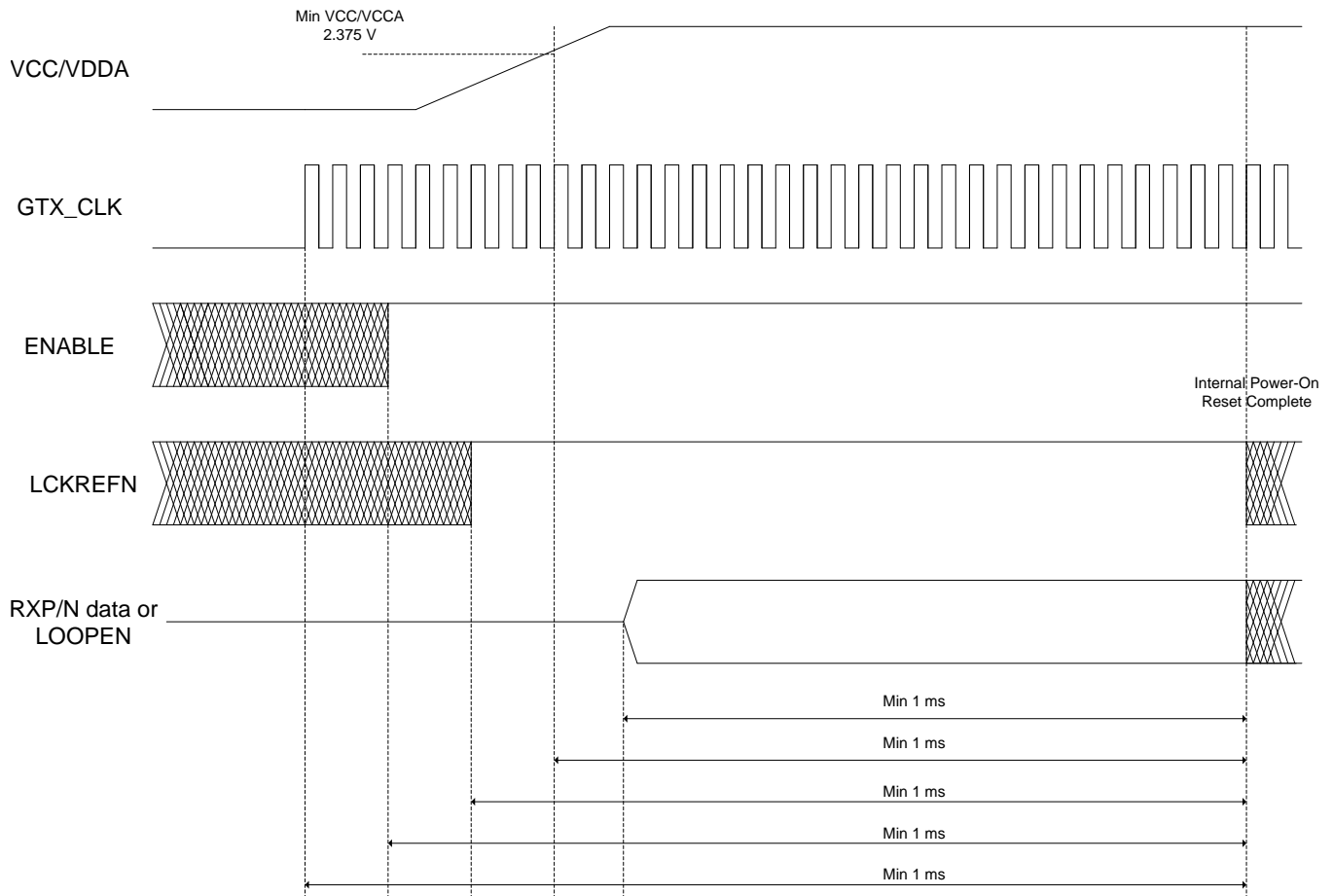

Figure 12. Power-On/Reset Timing Diagram (Option 1)

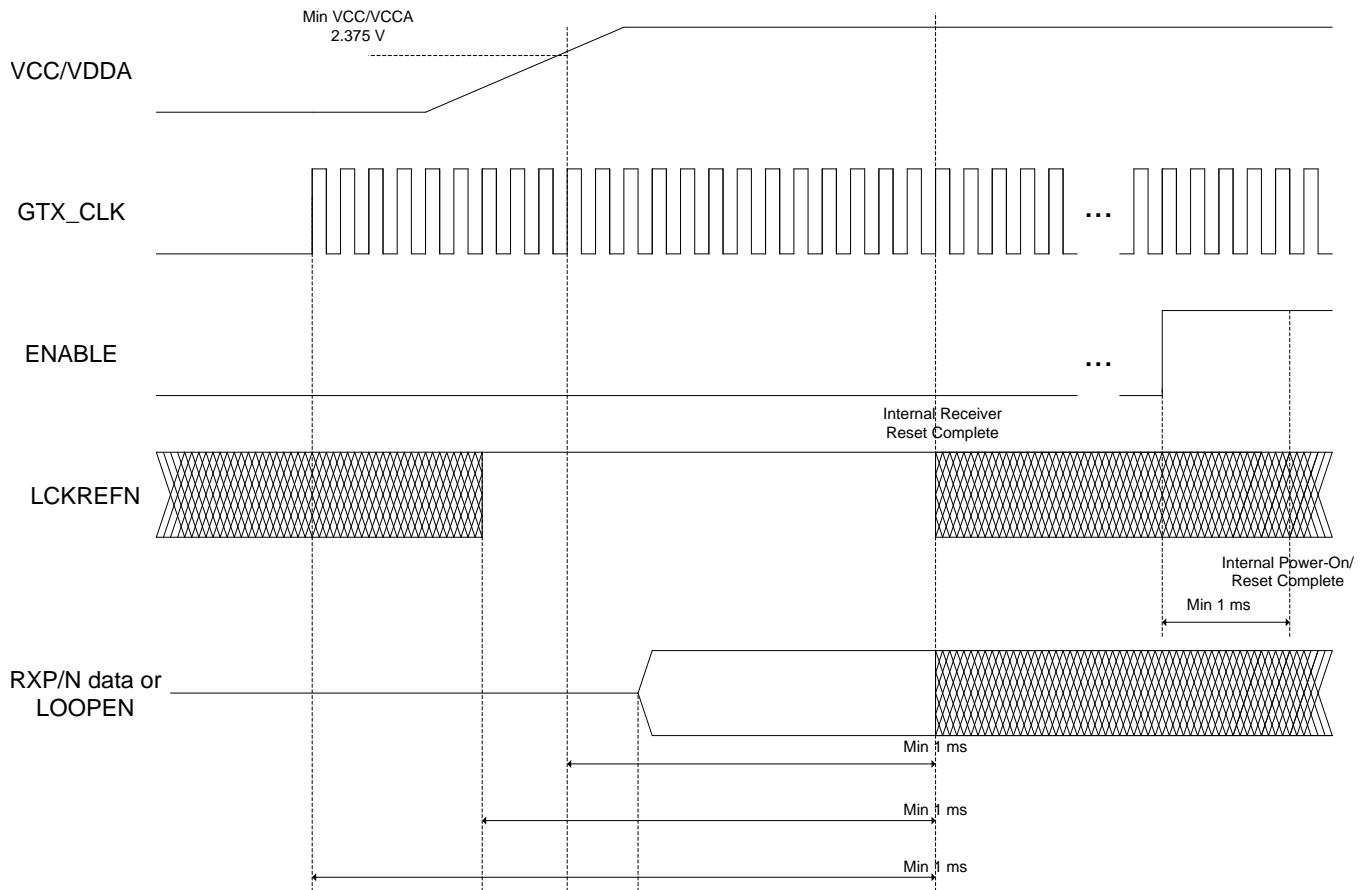

Figure 13. Power-On/Reset Timing Diagram (Option 2)

8.4 Device Functional Modes

8.4.1 Power-Down Mode

The TLK2711-SP goes into power-down mode when the ENABLE pin is pulled low. In the power-down mode, the serial transmit pins (TXN), the receive data bus pins (RXD0 to RXD15), and RKL5B goes into a high-impedance state. In the power-down condition, the signal detection circuit draws less than 15 mW. When the TLK2711-SP is in the power-down mode, the clock signal on the TXCLK pin must be provided if LOS functionality is needed.

8.4.2 High-Speed I/O Directly-Coupled Mode

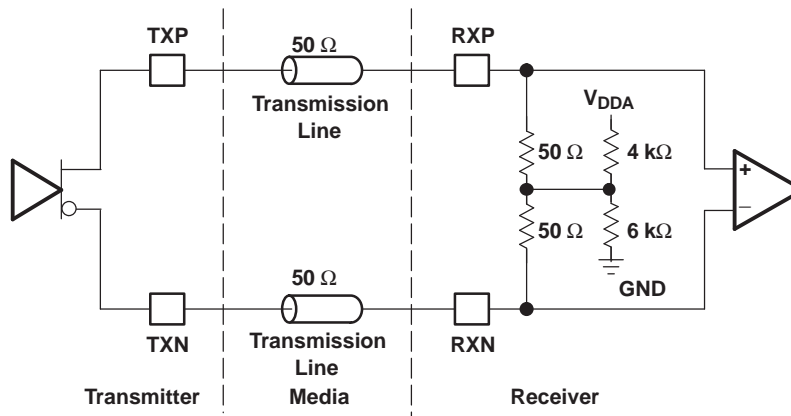

Figure 14. High-Speed I/O Directly-Coupled Mode Schematic

8.4.3 High-Speed I/O AC-Coupled Mode

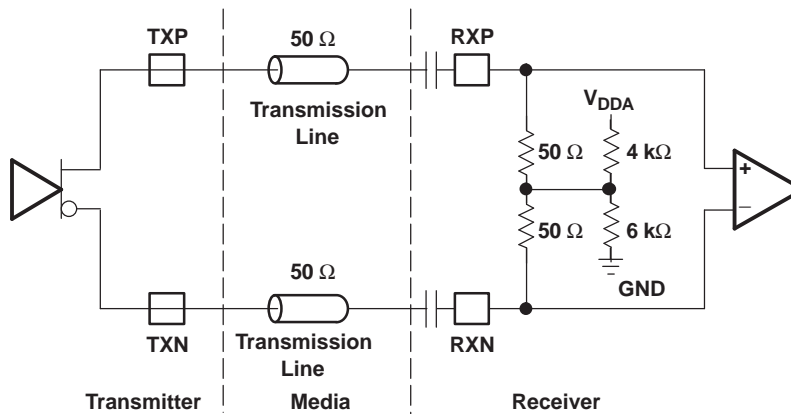

Figure 15. High-Speed I/O AC-Coupled Mode Schematic

9 Application and Implementation

9.1 Application Information

The TLK2711-SP may be operated as full link with send/receive functions or each end of link may be transmit only or receive only.

The transmitter is always operational in either case as GTX_CLK is required to source the PLL. In transmit only cases, LCKREFN can be pulled low to disable the RX interface. See [Power-On Reset](#) for requirements.

9.2 Typical Application

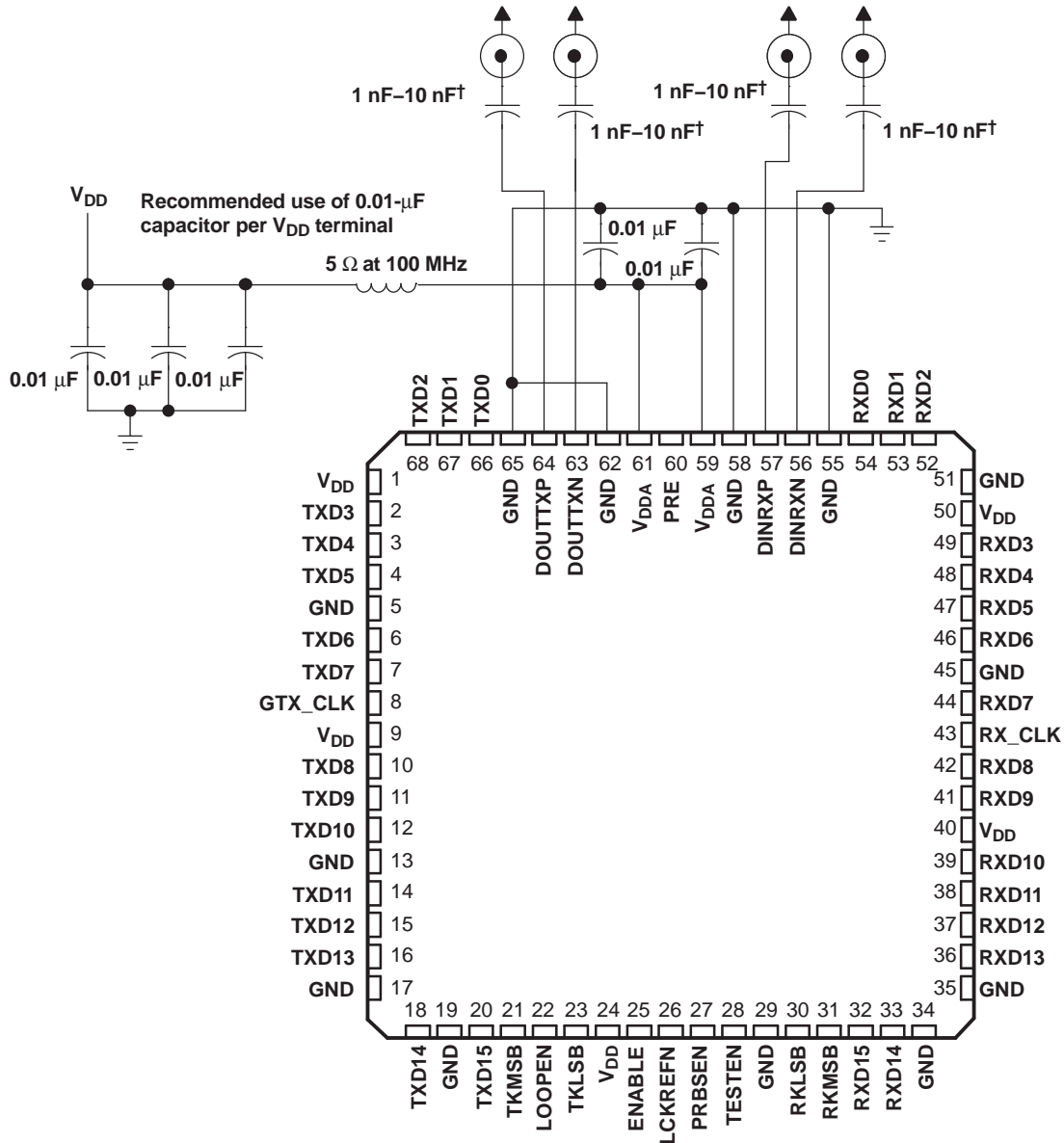

† For ac coupling

Figure 16. External Component Interconnection

Typical Application (continued)

9.2.1 Design Requirements

Input conditions in the data sheet were created and validated to achieve a bit error rate (BER) of 1 error in 1E12 bits or better. Other aspects that affect BER are power supply noise, quality (loss), and matching of 50-Ω controlled impedance for transmit and receive differential pins.

9.2.2 Detailed Design Procedure

Detailed design procedures involve careful examination of system properties, design, and error rate goals. Understanding these properties allows for creation of jitter budget to ensure design BER goals are achieved. Application note [SLLA071](#) is based on the TLK2500. The TLK2500 shares the same architecture and similar jitter properties.

9.2.3 Application Curves

[Figure 17](#) shows typical TTL output voltage characteristics at maximum 2-mA load at minimum $V_{CC} = 2.375$ V. [Figure 18](#) shows typical differential output voltage $V_{OD}(p)$ across temperature for each preemphasis condition at minimum $V_{CC} = 2.375$ V. $V_{OD}(1)$ represents 20% emphasis enabled. $V_{OD}(0)$ represents 5% emphasis enabled.

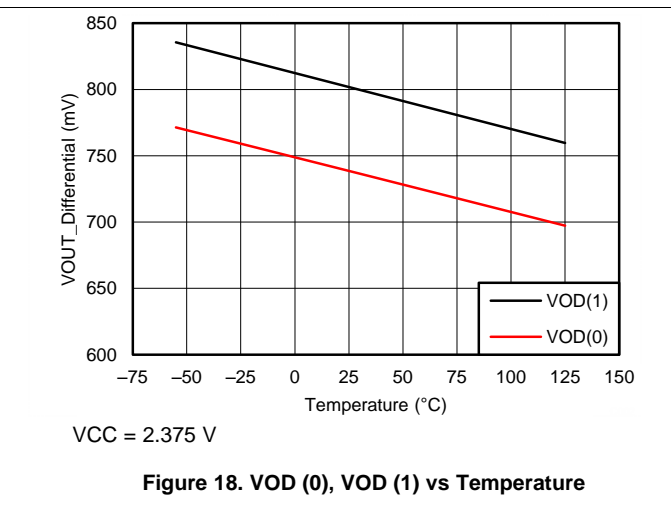
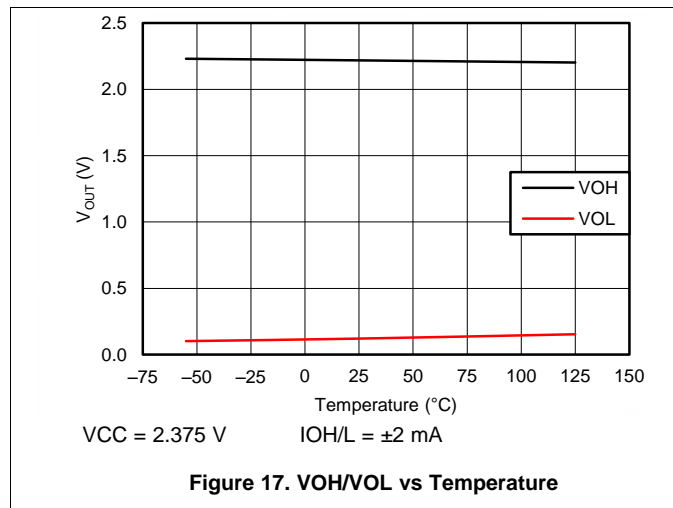

10 Power Supply Recommendations

Power supplies must be within recommended operating range and should have less than 100 mV of ripple. Exceeding 100-mV ripple can impact transmitted jitter and receiver jitter tolerance.

VDDA should be filtered from VDD. Filter values should be set to minimize any frequency components from power supply and/or digital logic that may exist in the system in the range of the PLL jitter transfer characteristics. The PLL is sensitive to noise in the range of 300 kHz to 3 MHz.

11 Layout

11.1 Layout Guidelines

Standard high-speed differential routing best practices must be employed. Routing should be 50-Ω matched impedance and length for differential transmit and receive. Minimize layer transitions and stubs to reduce any impedance mismatches. Connecting the thermal pad to board ground improves device performance by supplying lower impedance path to ground minimizing ground bounce and improves thermal dissipation.

11.2 Layout Example

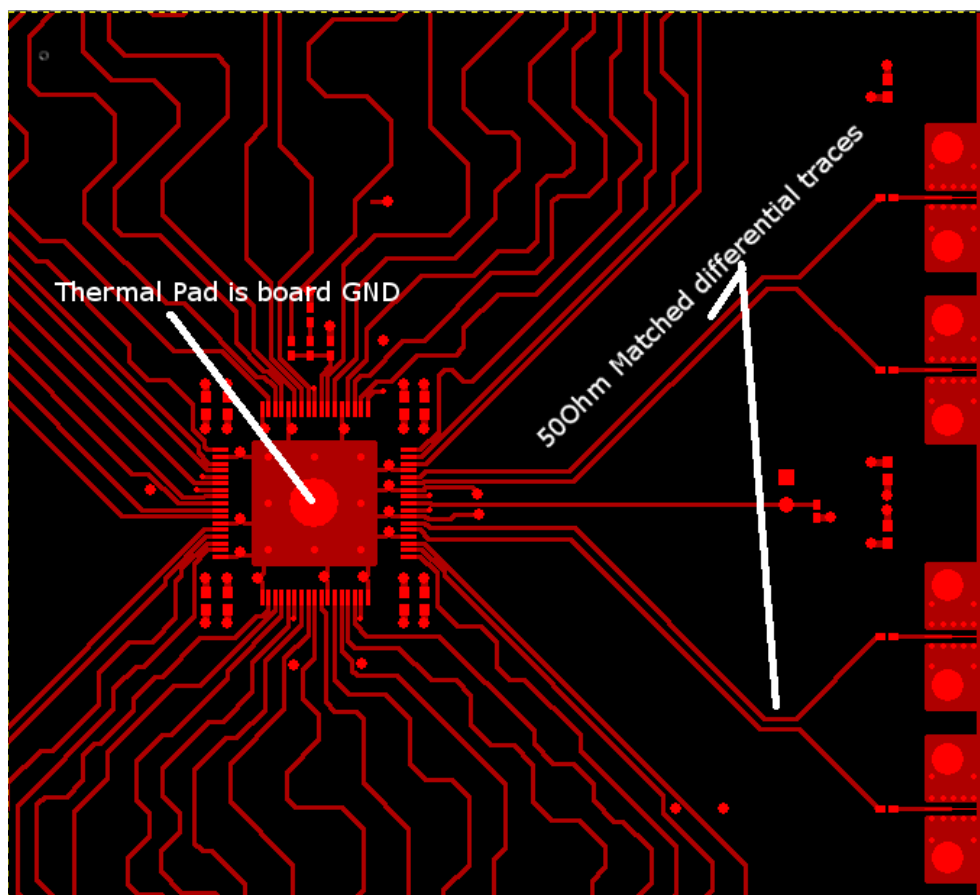

12 Device and Documentation Support

12.1 Trademarks

All trademarks are the property of their respective owners.

12.2 Electrostatic Discharge Caution



These devices have limited built-in ESD protection. The leads should be shorted together or the device placed in conductive foam during storage or handling to prevent electrostatic damage to the MOS gates.

12.3 Glossary



[SLYZ022](#) — *TI Glossary*.

This glossary lists and explains terms, acronyms, and definitions.

13 Mechanical, Packaging, and Orderable Information

The following pages include mechanical, packaging, and orderable information. This information is the most current data available for the designated devices. This data is subject to change without notice and revision of this document. For browser-based versions of this data sheet, refer to the left-hand navigation.

PACKAGING INFORMATION

Orderable Device	Status (1)	Package Type	Package Drawing	Pins	Package Qty	Eco Plan (2)	Lead/Ball Finish (6)	MSL Peak Temp (3)	Op Temp (°C)	Device Marking (4/5)	Samples
5962-0522101VXC	ACTIVE	CFP	HFG	68	1	TBD	Call TI	N / A for Pkg Type	-55 to 125	5962-0522101VXC TLK2711HFGQMLV	
TLK2711HFG/EM	ACTIVE	CFP	HFG	68	1	TBD	Call TI	N / A for Pkg Type	25 Only	TLK2711HFG/EM EVAL ONLY	

(1) The marketing status values are defined as follows:

ACTIVE: Product device recommended for new designs.

LIFEBUY: TI has announced that the device will be discontinued, and a lifetime-buy period is in effect.

NRND: Not recommended for new designs. Device is in production to support existing customers, but TI does not recommend using this part in a new design.

PREVIEW: Device has been announced but is not in production. Samples may or may not be available.

OBSOLETE: TI has discontinued the production of the device.

(2) Eco Plan - The planned eco-friendly classification: Pb-Free (RoHS), Pb-Free (RoHS Exempt), or Green (RoHS & no Sb/Br) - please check <http://www.ti.com/productcontent> for the latest availability information and additional product content details.

TBD: The Pb-Free/Green conversion plan has not been defined.

Pb-Free (RoHS): TI's terms "Lead-Free" or "Pb-Free" mean semiconductor products that are compatible with the current RoHS requirements for all 6 substances, including the requirement that lead not exceed 0.1% by weight in homogeneous materials. Where designed to be soldered at high temperatures, TI Pb-Free products are suitable for use in specified lead-free processes.

Pb-Free (RoHS Exempt): This component has a RoHS exemption for either 1) lead-based flip-chip solder bumps used between the die and package, or 2) lead-based die adhesive used between the die and leadframe. The component is otherwise considered Pb-Free (RoHS compatible) as defined above.

Green (RoHS & no Sb/Br): TI defines "Green" to mean Pb-Free (RoHS compatible), and free of Bromine (Br) and Antimony (Sb) based flame retardants (Br or Sb do not exceed 0.1% by weight in homogeneous material)

(3) MSL, Peak Temp. - The Moisture Sensitivity Level rating according to the JEDEC industry standard classifications, and peak solder temperature.

(4) There may be additional marking, which relates to the logo, the lot trace code information, or the environmental category on the device.

(5) Multiple Device Markings will be inside parentheses. Only one Device Marking contained in parentheses and separated by a "~" will appear on a device. If a line is indented then it is a continuation of the previous line and the two combined represent the entire Device Marking for that device.

(6) Lead/Ball Finish - Orderable Devices may have multiple material finish options. Finish options are separated by a vertical ruled line. Lead/Ball Finish values may wrap to two lines if the finish value exceeds the maximum column width.

Important Information and Disclaimer: The information provided on this page represents TI's knowledge and belief as of the date that it is provided. TI bases its knowledge and belief on information provided by third parties, and makes no representation or warranty as to the accuracy of such information. Efforts are underway to better integrate information from third parties. TI has taken and

continues to take reasonable steps to provide representative and accurate information but may not have conducted destructive testing or chemical analysis on incoming materials and chemicals. TI and TI suppliers consider certain information to be proprietary, and thus CAS numbers and other limited information may not be available for release.

In no event shall TI's liability arising out of such information exceed the total purchase price of the TI part(s) at issue in this document sold by TI to Customer on an annual basis.

OTHER QUALIFIED VERSIONS OF TLK2711-SP :

- Catalog: [TLK2711](#)

NOTE: Qualified Version Definitions:

- Catalog - TI's standard catalog product

HFG (S-CQFP-F68)

CERAMIC QUAD FLATPACK WITH NCTB

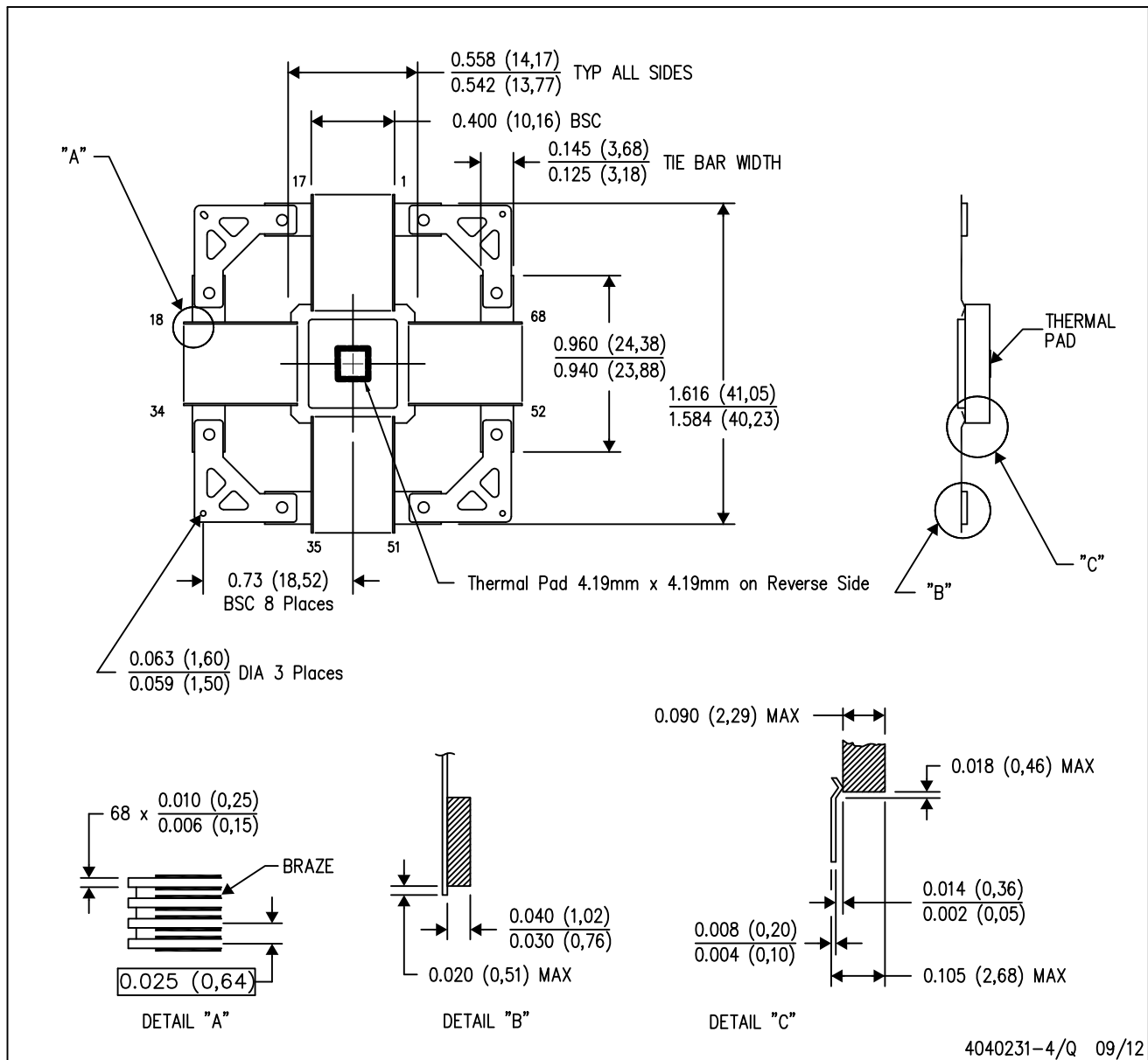

- NOTES:
- All linear dimensions are in inches (millimeters).
 - This drawing is subject to change without notice.
 - Ceramic quad flatpack with flat leads brazed to non-conductive tie bar carrier.
 - This package is hermetically sealed with a metal lid.
 - The leads are gold plated and can be solderdipped.
 - Leads not shown for clarity purposes.
 - Thermal dissipation enhancement provided by vias to external bottom pad.
 - Lid and Thermal pad are connected to GND leads.

IMPORTANT NOTICE

Texas Instruments Incorporated and its subsidiaries (TI) reserve the right to make corrections, enhancements, improvements and other changes to its semiconductor products and services per JESD46, latest issue, and to discontinue any product or service per JESD48, latest issue. Buyers should obtain the latest relevant information before placing orders and should verify that such information is current and complete. All semiconductor products (also referred to herein as "components") are sold subject to TI's terms and conditions of sale supplied at the time of order acknowledgment.

TI warrants performance of its components to the specifications applicable at the time of sale, in accordance with the warranty in TI's terms and conditions of sale of semiconductor products. Testing and other quality control techniques are used to the extent TI deems necessary to support this warranty. Except where mandated by applicable law, testing of all parameters of each component is not necessarily performed.

TI assumes no liability for applications assistance or the design of Buyers' products. Buyers are responsible for their products and applications using TI components. To minimize the risks associated with Buyers' products and applications, Buyers should provide adequate design and operating safeguards.

TI does not warrant or represent that any license, either express or implied, is granted under any patent right, copyright, mask work right, or other intellectual property right relating to any combination, machine, or process in which TI components or services are used. Information published by TI regarding third-party products or services does not constitute a license to use such products or services or a warranty or endorsement thereof. Use of such information may require a license from a third party under the patents or other intellectual property of the third party, or a license from TI under the patents or other intellectual property of TI.

Reproduction of significant portions of TI information in TI data books or data sheets is permissible only if reproduction is without alteration and is accompanied by all associated warranties, conditions, limitations, and notices. TI is not responsible or liable for such altered documentation. Information of third parties may be subject to additional restrictions.

Resale of TI components or services with statements different from or beyond the parameters stated by TI for that component or service voids all express and any implied warranties for the associated TI component or service and is an unfair and deceptive business practice. TI is not responsible or liable for any such statements.

Buyer acknowledges and agrees that it is solely responsible for compliance with all legal, regulatory and safety-related requirements concerning its products, and any use of TI components in its applications, notwithstanding any applications-related information or support that may be provided by TI. Buyer represents and agrees that it has all the necessary expertise to create and implement safeguards which anticipate dangerous consequences of failures, monitor failures and their consequences, lessen the likelihood of failures that might cause harm and take appropriate remedial actions. Buyer will fully indemnify TI and its representatives against any damages arising out of the use of any TI components in safety-critical applications.

In some cases, TI components may be promoted specifically to facilitate safety-related applications. With such components, TI's goal is to help enable customers to design and create their own end-product solutions that meet applicable functional safety standards and requirements. Nonetheless, such components are subject to these terms.

No TI components are authorized for use in FDA Class III (or similar life-critical medical equipment) unless authorized officers of the parties have executed a special agreement specifically governing such use.

Only those TI components which TI has specifically designated as military grade or "enhanced plastic" are designed and intended for use in military/aerospace applications or environments. Buyer acknowledges and agrees that any military or aerospace use of TI components which have **not** been so designated is solely at the Buyer's risk, and that Buyer is solely responsible for compliance with all legal and regulatory requirements in connection with such use.

TI has specifically designated certain components as meeting ISO/TS16949 requirements, mainly for automotive use. In any case of use of non-designated products, TI will not be responsible for any failure to meet ISO/TS16949.

Products

Audio	www.ti.com/audio
Amplifiers	amplifier.ti.com
Data Converters	dataconverter.ti.com
DLP® Products	www.dlp.com
DSP	dsp.ti.com
Clocks and Timers	www.ti.com/clocks
Interface	interface.ti.com
Logic	logic.ti.com
Power Mgmt	power.ti.com
Microcontrollers	microcontroller.ti.com
RFID	www.ti-rfid.com
OMAP Applications Processors	www.ti.com/omap
Wireless Connectivity	www.ti.com/wirelessconnectivity

Applications

Automotive and Transportation	www.ti.com/automotive
Communications and Telecom	www.ti.com/communications
Computers and Peripherals	www.ti.com/computers
Consumer Electronics	www.ti.com/consumer-apps
Energy and Lighting	www.ti.com/energy
Industrial	www.ti.com/industrial
Medical	www.ti.com/medical
Security	www.ti.com/security
Space, Avionics and Defense	www.ti.com/space-avionics-defense
Video and Imaging	www.ti.com/video

TI E2E Community

e2e.ti.com