

TLE5309D

Dual GMR/AMR Angle Sensor



Features

- Separate supply pins for AMR and GMR sensor
- Low current consumption and quick start up
- 360° contactless angle measurement
- Output amplitude optimized for circuits with 3.3 V or 5 V supply voltage
- Immune to airgap variations due to MR based sensing principle
- Operating temperature: -40°C to 125°C (ambient temperature)
- Pre-amplified output signals for differential or single-ended applications
- Diverse redundance design with one GMR sensor (top die) and one AMR sensor (bottom die) in one package
- Green product (RoHS compliant)

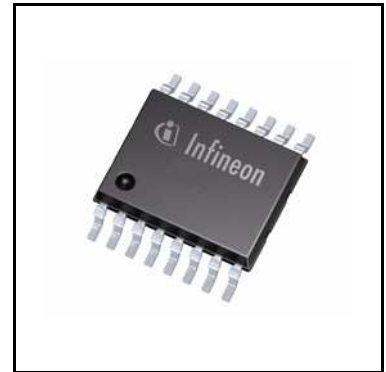

Product Validation

Developed for automotive applications. Product qualification according to AEC-Q100.

Potential Applications

The TLE5309D angle sensor is designed for angular position sensing in safety critical automotive and non-automotive applications. Its high accuracy and 360° measurement range combined with short propagation delay makes it suitable for systems with high speeds and high accuracy demands such as brush-less DC (BLDC) motors for actuators and electric power steering systems (EPS). At the same time its fast start-up time and low overall power consumption enables the device to be employed for low-power turn counting. Extremely low power consumption can be achieved with power cycling, where the advantage of fast power on time reduces the average power consumption.

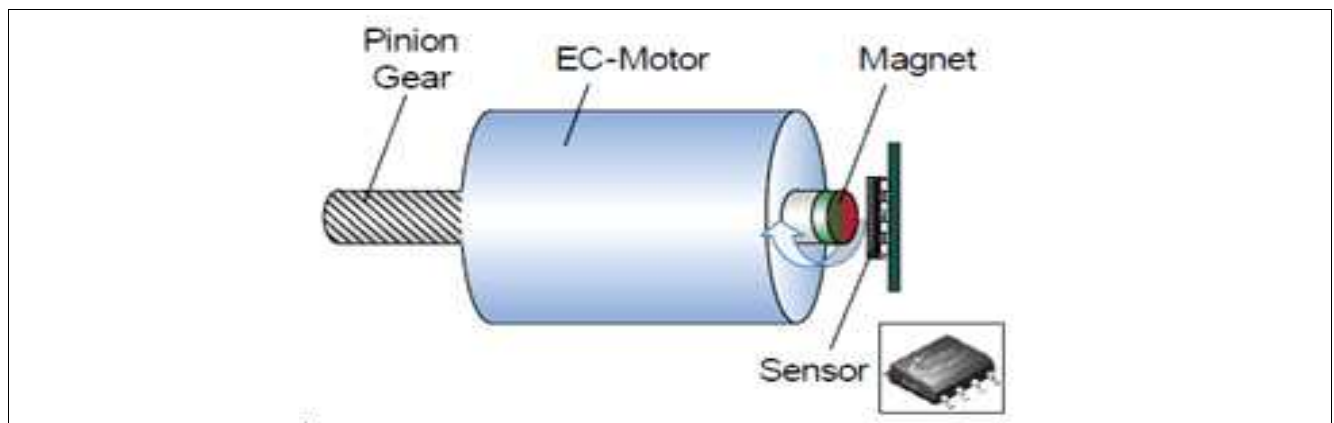

Figure 1 A usual application for TLE5309D is the electrically commutated motor

Description

The TLE5309D is a diverse redundant angle sensor with analog outputs. It combines a **Giant Magneto Resistance (GMR)** sensor for full 360° angle range with an **Anisotropic Magneto Resistance (AMR)** sensor for high precision in a flipped configuration in one package. Sine and cosine angle components of a rotating magnetic field are measured by **Magneto Resistive (MR)** elements. The sensors provide analog sine and cosine output voltages that describe the magnetic angle in a range of 0 to 180° (AMR sensor), and 0 to 360° (GMR sensor), respectively.

The differential MR bridge signals are independent of the magnetic field strength, and the analog output is designed for differential or single-ended applications.

The output voltages are designed to use the dynamic range of an A/D-converter using the same supply as the sensor as voltage reference. Both sensor ICs are supplied independently by separate supply and ground pins.

Table 1 Derivate ordering codes

Product Type	Marking	Ordering Code	Package	Description
TLE5309D E1211	309D1211	SP001227880	PG-TDSO-16	Dual Die AMR and GMR 3.3 V supply With TCO ¹⁾ Grade 1 ²⁾
TLE5309D E2211	309D2211	SP001227888	PG-TDSO-16	Dual Die AMR and GMR 5.0 V supply With TCO ¹⁾ Grade 1 ²⁾
TLE5309D E5201	309D5201	SP001227884	PG-TDSO-16	Dual Die AMR 5.0 V supply, GMR 3.3 V Without TCO ¹⁾ Grade 1 ²⁾

1) Temperature Compensation Offset

2) Part Operating Temperature Grades according to AEC-Q100

Table of Contents

	Features	1
	Product Validation	1
	Potential Applications	1
	Description	2
	Table of Contents	3
1	Functional description	4
1.1	General	4
1.2	Pin configuration	7
1.3	Pin description	7
1.4	Block diagram	8
1.5	Dual die angle output	9
2	Specification	10
2.1	Application circuit	10
2.2	Absolute maximum ratings	14
2.3	Sensor specification	15
2.3.1	Operating range	15
2.3.2	Electrical parameters	16
2.3.3	Output parameters	16
2.4	Error diagnosis	21
2.5	Angle performance	21
2.6	Electrostatic discharge protection	24
2.7	Electro magnetic compatibility (EMC)	24
3	Package information	25
3.1	Package parameters	25
3.2	Package outlines	25
3.3	Footprint	27
3.4	Packing	27
3.5	Marking	28
4	Revision history	29

1 Functional description

1.1 General

The TLE5309D comprises one GMR-based angle sensor IC mounted on the top and one AMR-based angle sensor IC mounted on the bottom of a package lead frame in a flipped configuration, so the positions of the sensitive elements in the package-plane coincide. This mounting technique ensures a minimum deviation of the magnetic field orientation sensed by the two chips.

The Magneto Resistive (MR) sensors are implemented using vertical integration. This means that the MR sensitive areas are integrated above the analog portion of the ICs. These MR elements change their resistance depending on the direction of the magnetic field.

On each sensor, four individual MR elements are connected in a Wheatstone bridge arrangement. Each MR element senses one of two components of the applied magnetic field:

- X component, V_x (cosine) or the
- Y component, V_y (sine)

The advantage of a full-bridge structure is that the amplitude of the MR signal is doubled and temperature effects cancel out.

GMR Sensor

The output signal of a GMR bridge is unambiguous in a range of 180°. Therefore two bridges are oriented orthogonally to each other to measure 360°.

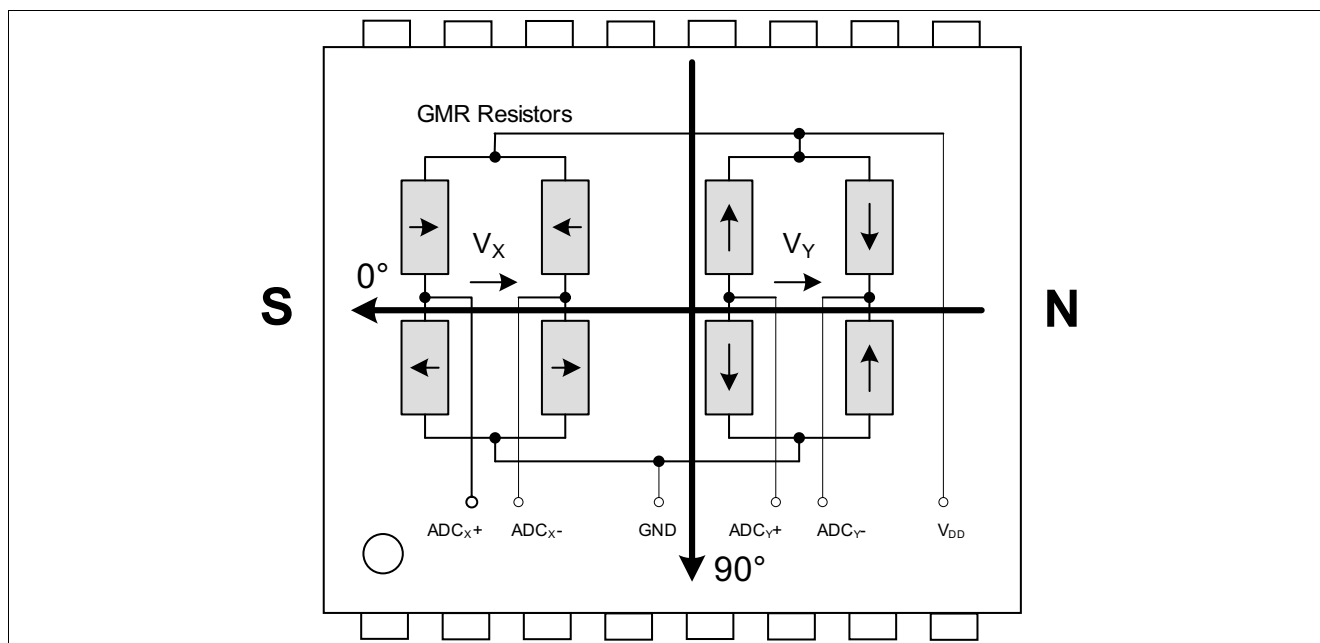

Figure 2 Sensitive bridges of the GMR sensor (top die)

Note: In Figure 2, the arrows in the resistors symbolize the direction of the reference layer. Size of the sensitive areas is greatly exaggerated for better visualization.

Functional description

With the trigonometric function ARCTAN2, the true 360° angle value that is represented by the relation of X and Y signals can be calculated according to [Equation \(1\)](#).

$$\alpha = \arctan2(V_x, V_y) \tag{1}$$

The ARCTAN2 function is a microcontroller library function which resolves an angle within 360° using the x and y coordinates on a unit circle.

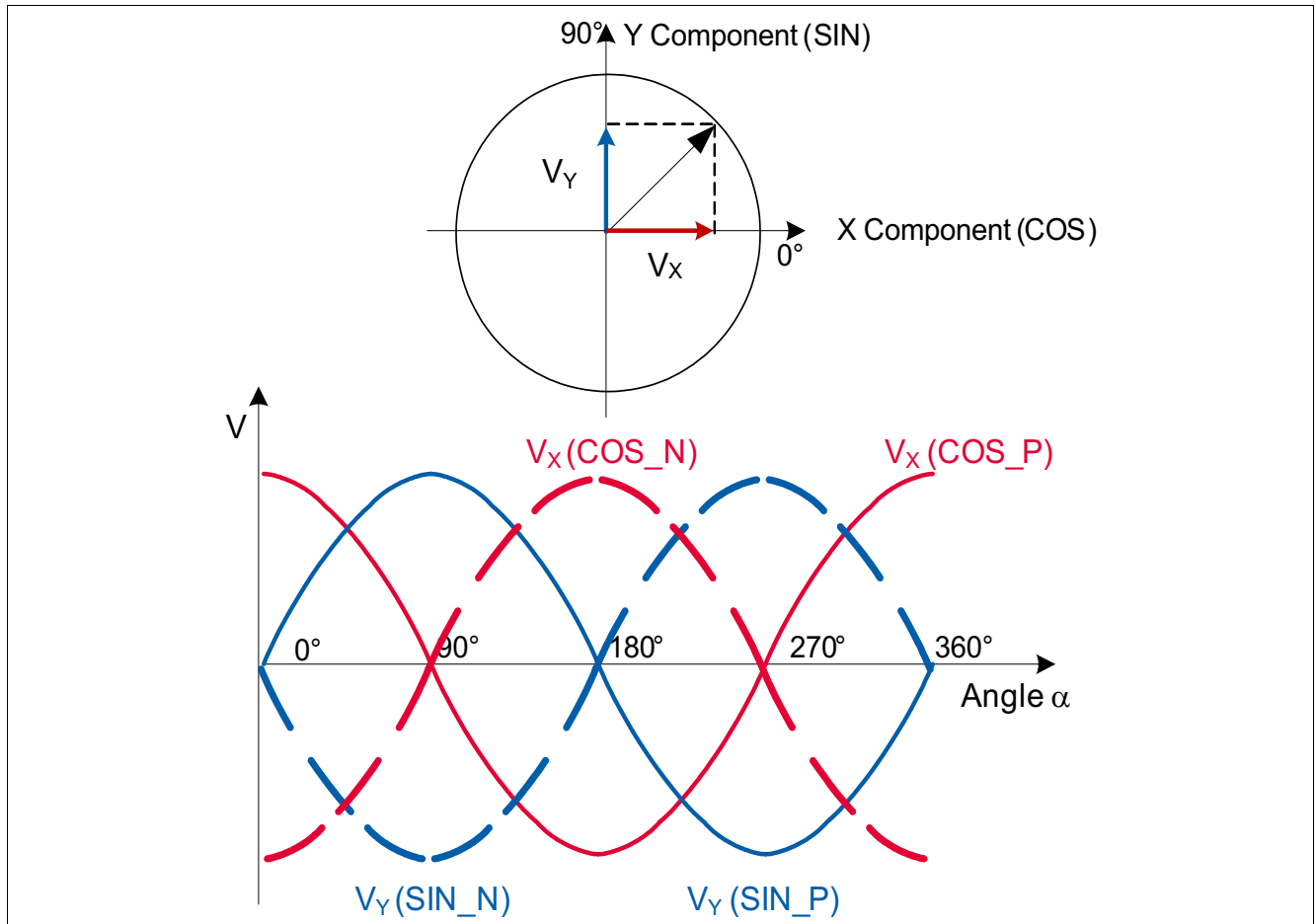

Figure 3 Ideal output of the GMR sensor bridges

Functional description

AMR sensor

The output signal of an AMR bridge is unambiguous in a range of 90°. Therefore two bridges are oriented at an angle of 45° to each other to measure 180°.

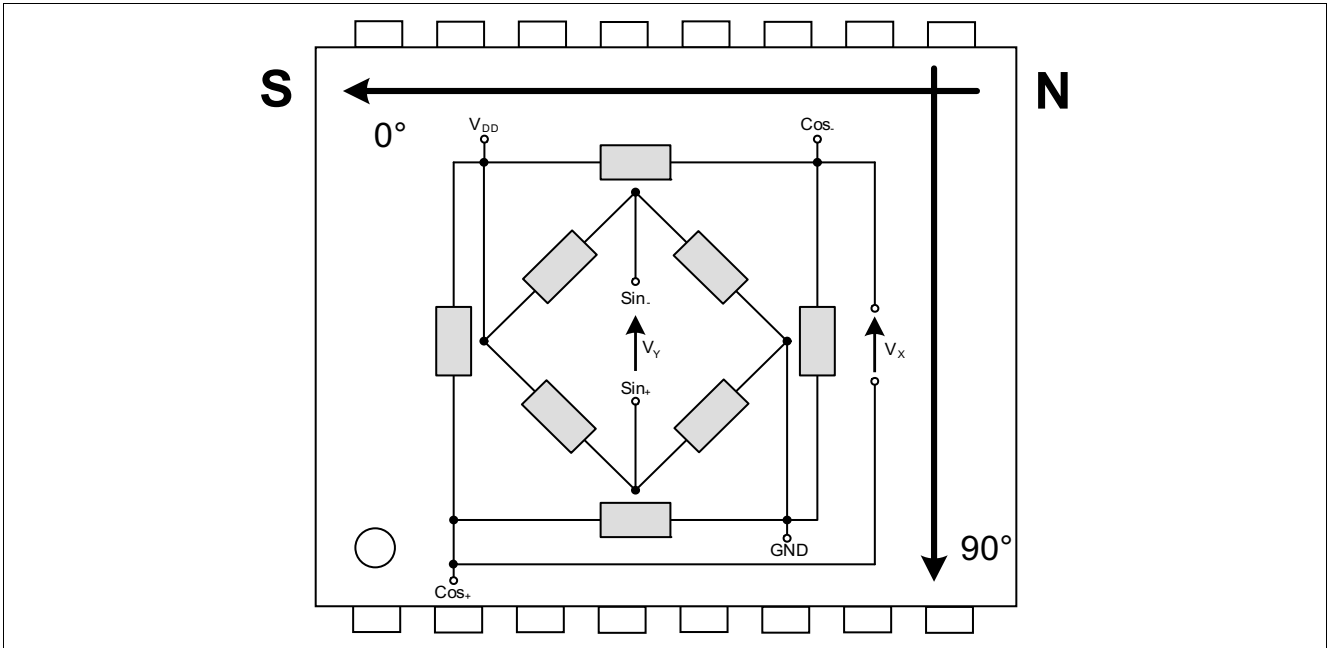

Figure 4 Sensitive bridges of the AMR sensor (bottom die)

Note: In Figure 4, the size of the sensitive areas is greatly exaggerated for better visualization.

With the trigonometric function ARCTAN2, the true 180° angle value that is represented by the relation of X and Y signals can be calculated according to Equation (2). The AMR sensing element internally measures the double angle, so the result has to be divided by 2. At external magnetic angles α between 180° and 360°, the angle measured by the sensor is $\alpha - 180^\circ$.

$$\alpha = \arctan2(V_x, V_y) / 2 \tag{2}$$

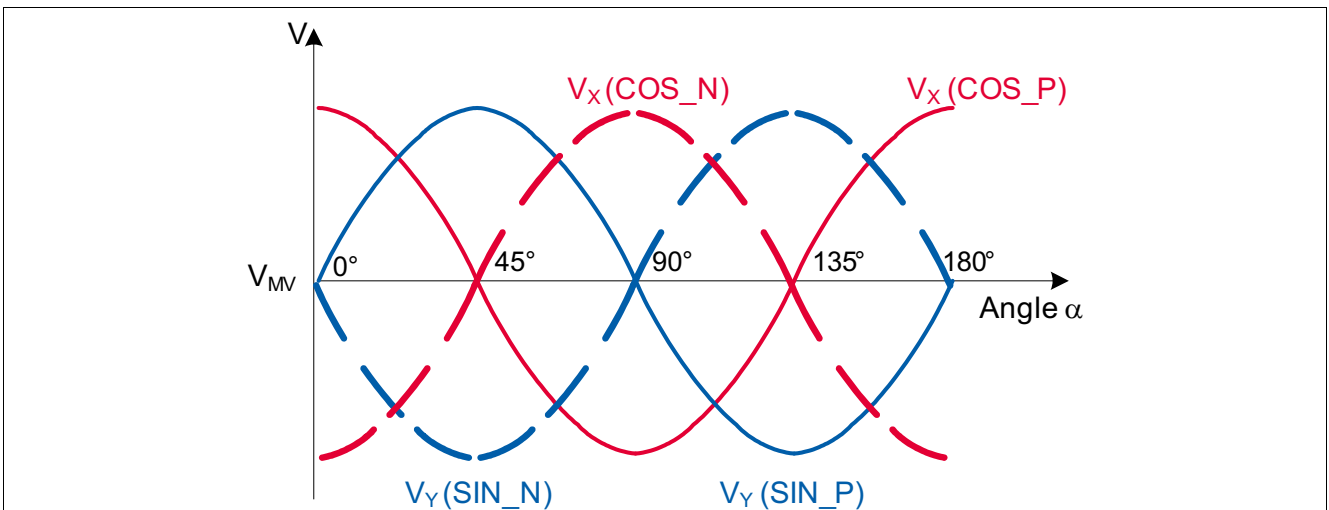

Figure 5 Ideal output of the AMR sensor bridges

Functional description

1.2 Pin configuration

The sensitive area is located at the center of the chip.

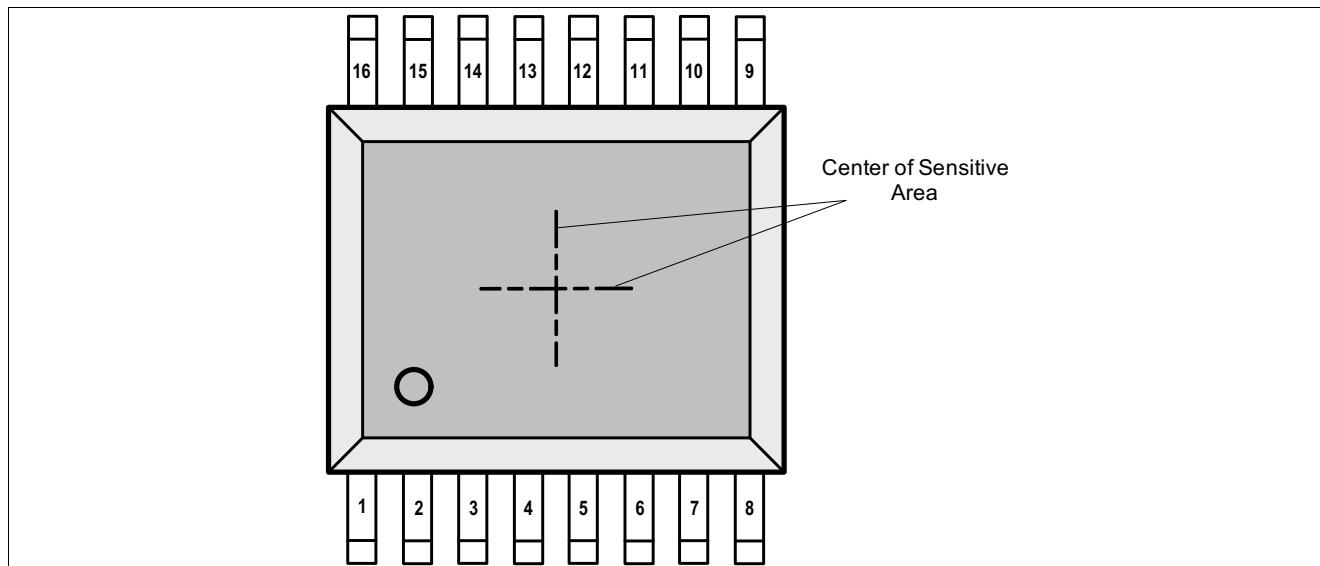

Figure 6 Pin configuration (top view)

1.3 Pin description

Table 2 Pin description

Pin No.	Pin Name	In/Out	Function
1	GMR_V _{DIAG}	O	GMR Sensor bridge voltage proportional to temperature. Diagnostic function
2	GMR_V _{DD}		GMR Sensor Supply voltage
3	GMR_SIN_N	O	GMR Sensor Analog negative sine output
4	GMR_SIN_P	O	GMR Sensor Analog positive sine output
5	AMR_SIN_P	O	AMR Sensor Analog positive sine output
6	AMR_SIN_N	O	AMR Sensor Analog negative sine output
7	AMR_V _{DD}		AMR Sensor Supply voltage
8	AMR_V _{DIAG}	O	AMR Sensor bridge voltage proportional to temperature. Diagnostic function
9	AMR_GND		AMR Sensor Ground
10	AMR_GND		AMR Sensor Ground
11	AMR_COS_N	O	AMR Sensor Analog negative cosine output
12	AMR_COS_P	O	AMR Sensor Analog positive cosine output
13	GMR_COS_P	O	GMR Sensor Analog positive cosine output
14	GMR_COS_N	O	GMR Sensor Analog negative cosine output
15	GMR_GND		GMR Sensor Ground
16	GMR_GND		GMR Sensor Ground

Functional description

1.4 Block diagram

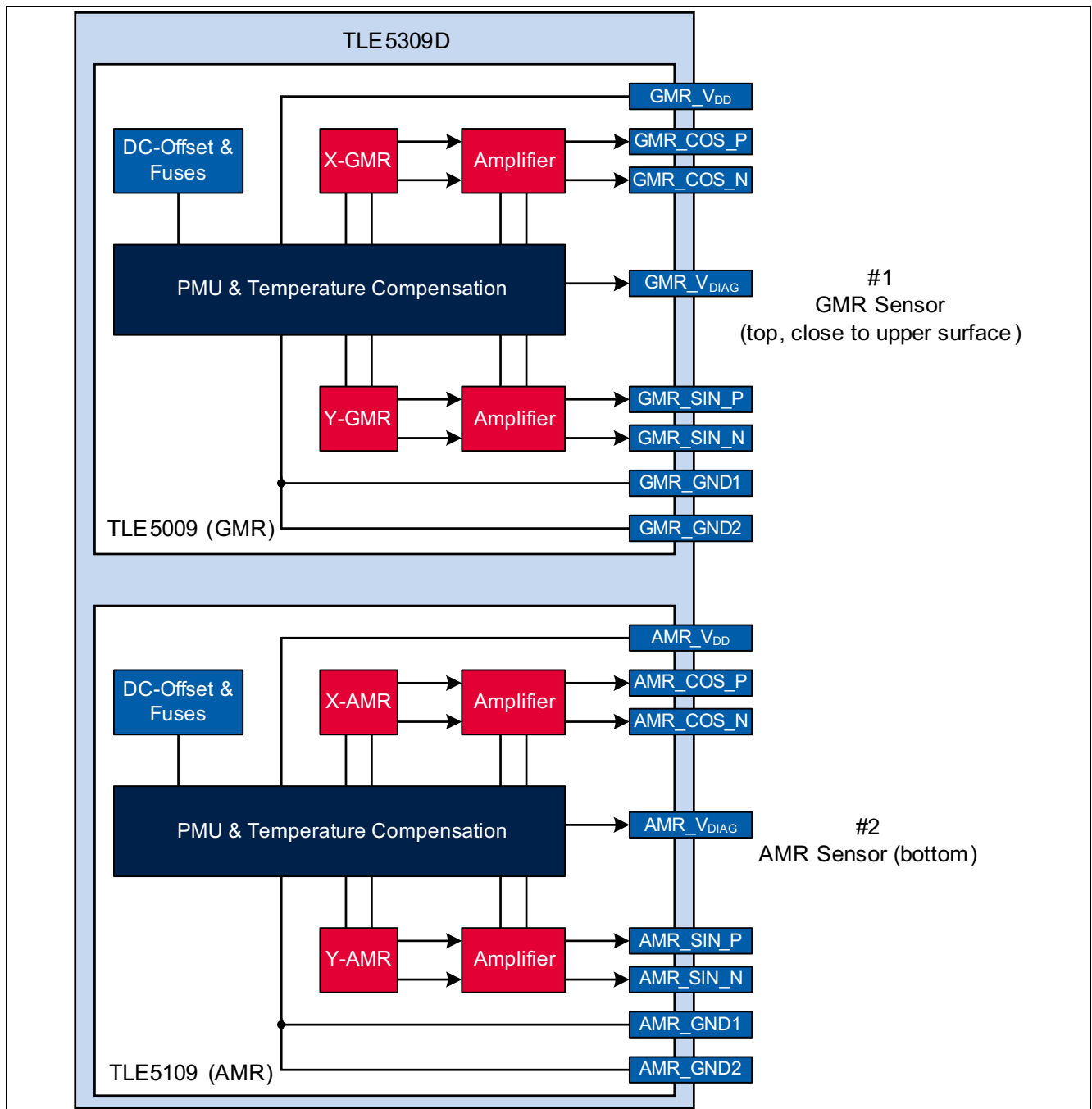

Figure 7 TLE5309D block diagram

Functional description

1.5 Dual die angle output

The bottom sensor element of the TLE5309D is an AMR sensor, the signal of which is only unambiguous over 180°. Therefore, in the angle range of 180° to 360° of the GMR sensor, the AMR sensor output signal will be in a range of 0° to 180° again. This behavior is illustrated in **Figure 8**, which shows the angle calculated according to **Equation (1)** and **Equation (2)** from the output of the GMR and AMR sensors, respectively, for a given external magnetic field orientation.

If in an application a different output of the two sensors is desired, the connections to the SIN_N and SIN_P or COS_N and COS_P pins on the printed circuit board can be interchanged. The consequence of this change of connections is that either the differential sine or the cosine signal are inverted, which corresponds to a change of rotation direction (see dashed line in **Figure 8**).

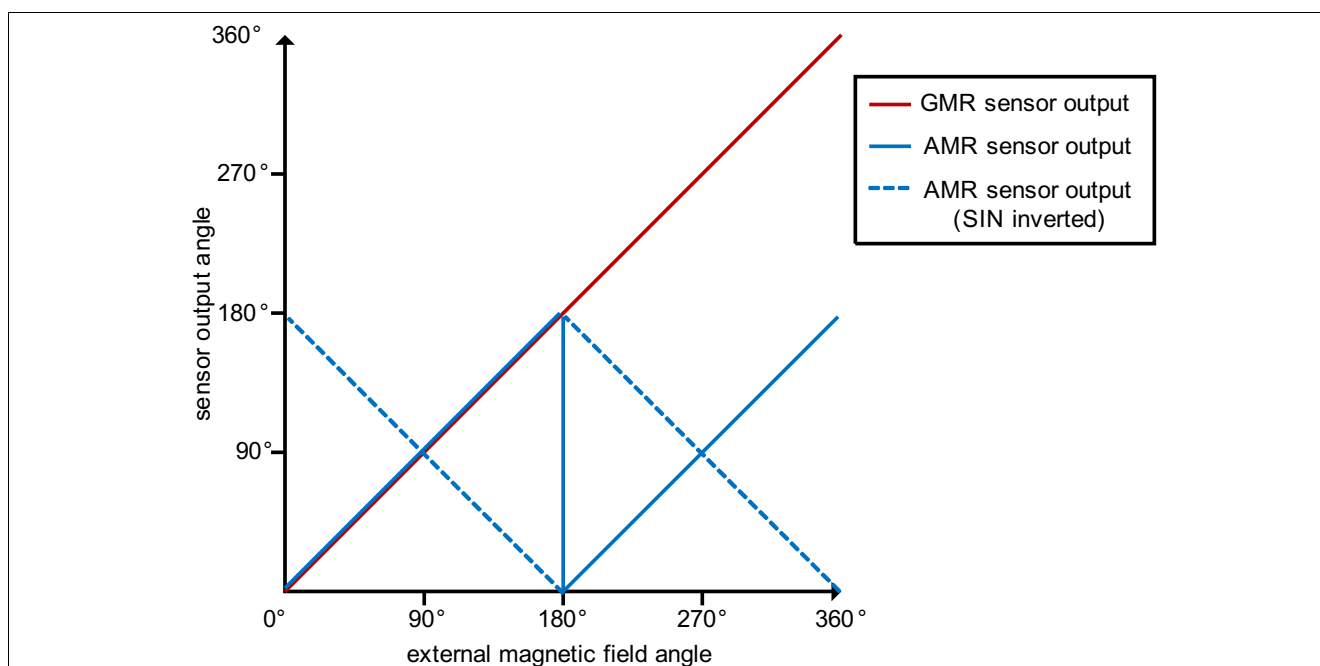

Figure 8 Dual die angle output

Attention: *The positioning accuracy of each sensor IC in the package is $\pm 3^\circ$. Thus, the relative rotation of the two sensor ICs can be up to 6° , resulting in a constant offset of the angle output of up to 6° , which has to be measured in an end-of-line calibration and taken into account during operation of the TLE5309D.*

2 Specification

2.1 Application circuit

The TLE5309D sensor can be used in single-ended or differential output mode. **Figure 9** shows a typical application circuit for the TLE5309D in single-ended output mode using the positive output channels. For single-ended operation the positive or negative output channels can be used. Unused single-ended output pins should preferably be floating or connected to GND with a high-ohmic resistance ($> 100\text{ k}\Omega$). The TLE5309D has separate supply pins for the GMR sensor and the AMR sensor. The microcontroller comprises up to 10 A/D inputs used to receive the sensor output signals in differential output mode, illustrated in **Figure 10**. For reasons of EMC and output filtering, the following RC low pass arrangement is recommended. The RC low pass has to be adapted according to the applied rotation speed. ¹⁾

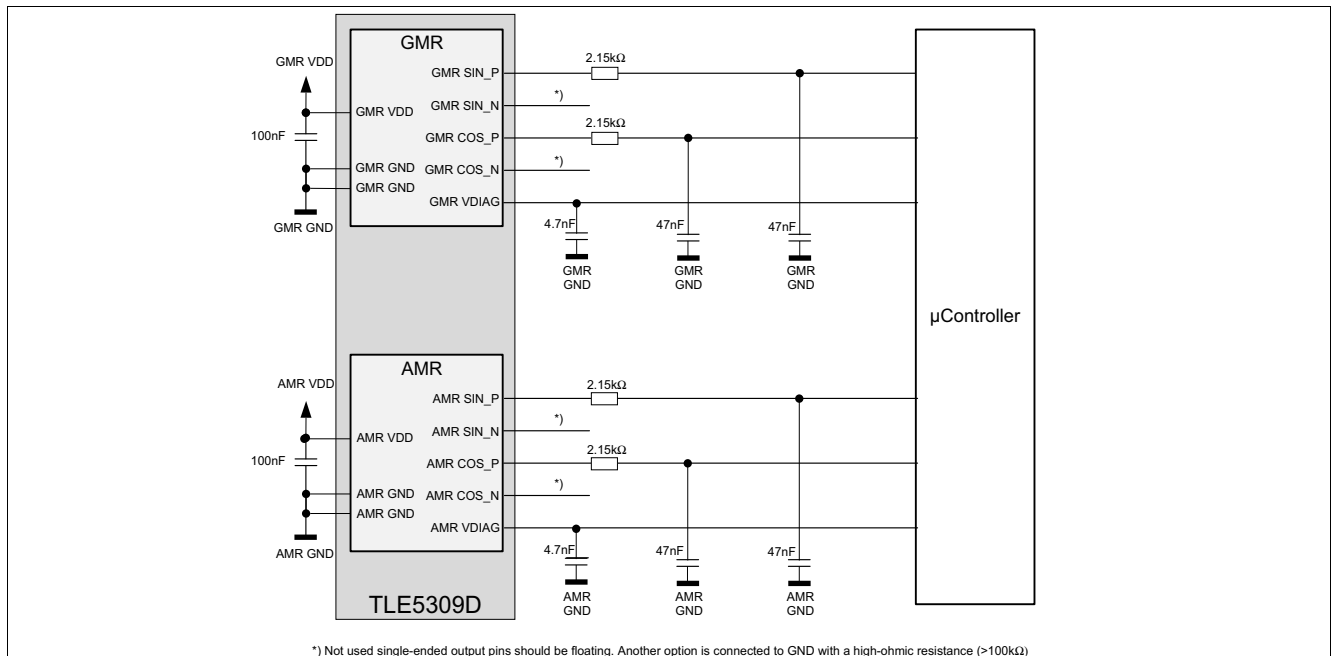

Figure 9 Application circuit for the TLE5309D in single-ended output mode; positive output channels used

1) E. g. the RC low pass with $R=2.15\text{ k}\Omega$ and $C=47\text{ nF}$ is appropriate for a rotation speed up to 60,000 rpm.

Specification

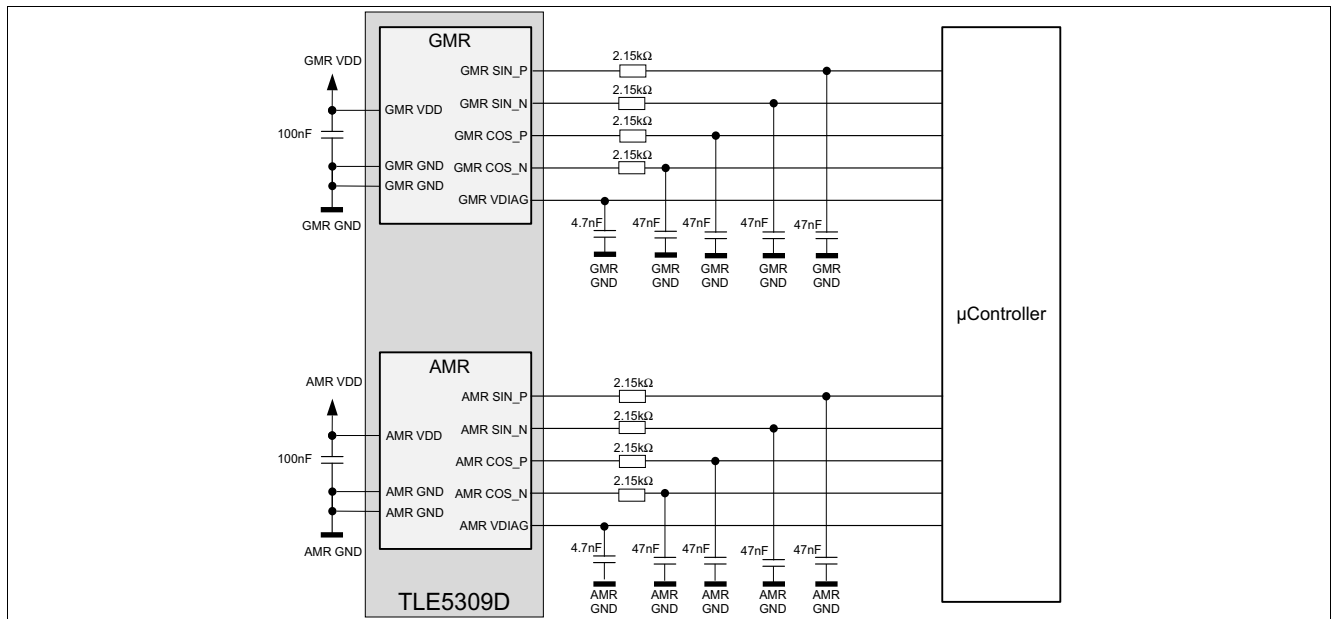

Figure 10 Application circuit for the TLE5309D in differential output mode

Application circuit for low-power consumption (e.g. turn counter)

Applications that use electric motors and actuators may require a turn counter function. A turn counter function allows to keep track of the electric motor or actuator position with low-power consumption. During operation the sensor is powered on, therefore the angle information is constantly available and, if necessary, stored. But when the system is not in operation the sensor is powered off to save power consumption, therefore rotational movements are not detected. To avoid missing the position the sensor can be awaked periodically to obtain the angle information. The minimum length of the awake time must cover the TLE5309D power-up time (described in Table 5) and the required time to transmit the data, which is also dependent on the application circuit.

An optimal TLE5309D application circuit for systems with turn counter function is shown in Figure 11 for single-ended output respectively in Figure 12 for differential output. With a lower resistor and capacitor design the low-pass filter has a time constant of only a few microseconds. Therefore, the time needed to supply the TLE5309D with power in order to read the output signal is considerably reduced.

Specification

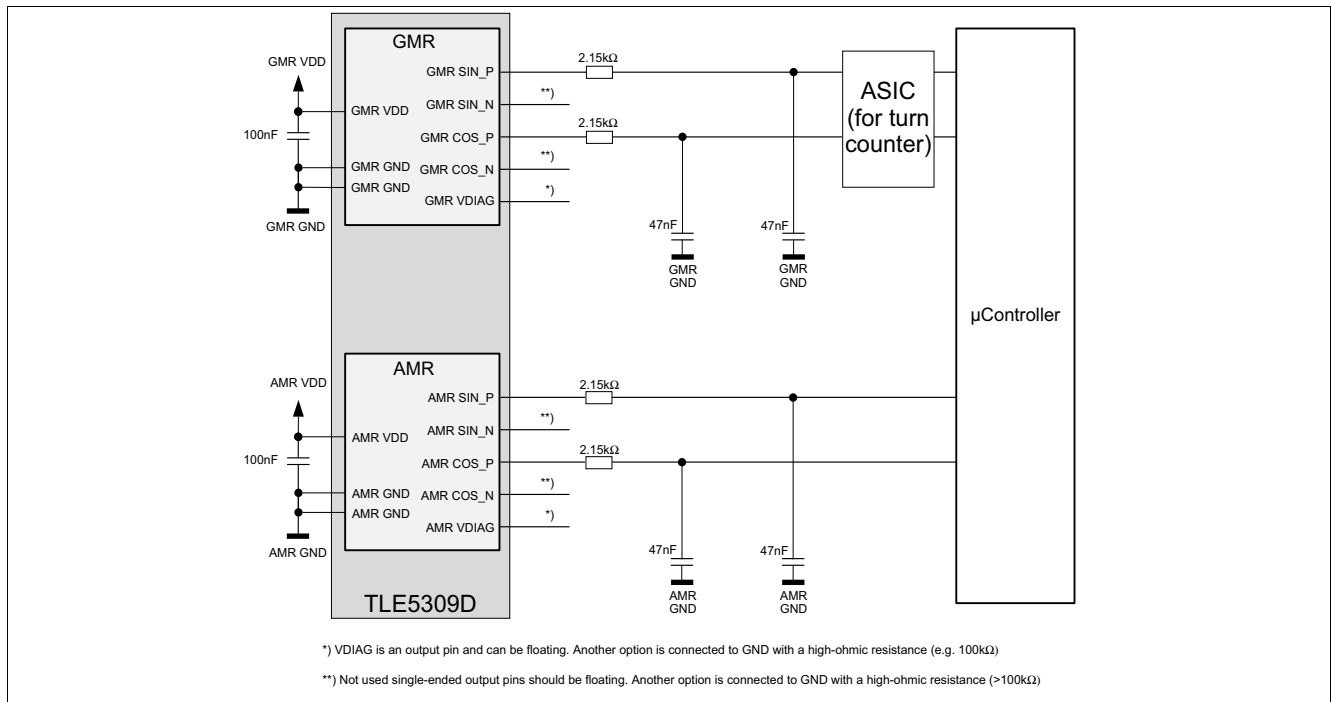

Figure 11 Application circuit for the TLE5309D in low-power applications in single-ended output mode (e.g. turn counter); positive output channels used

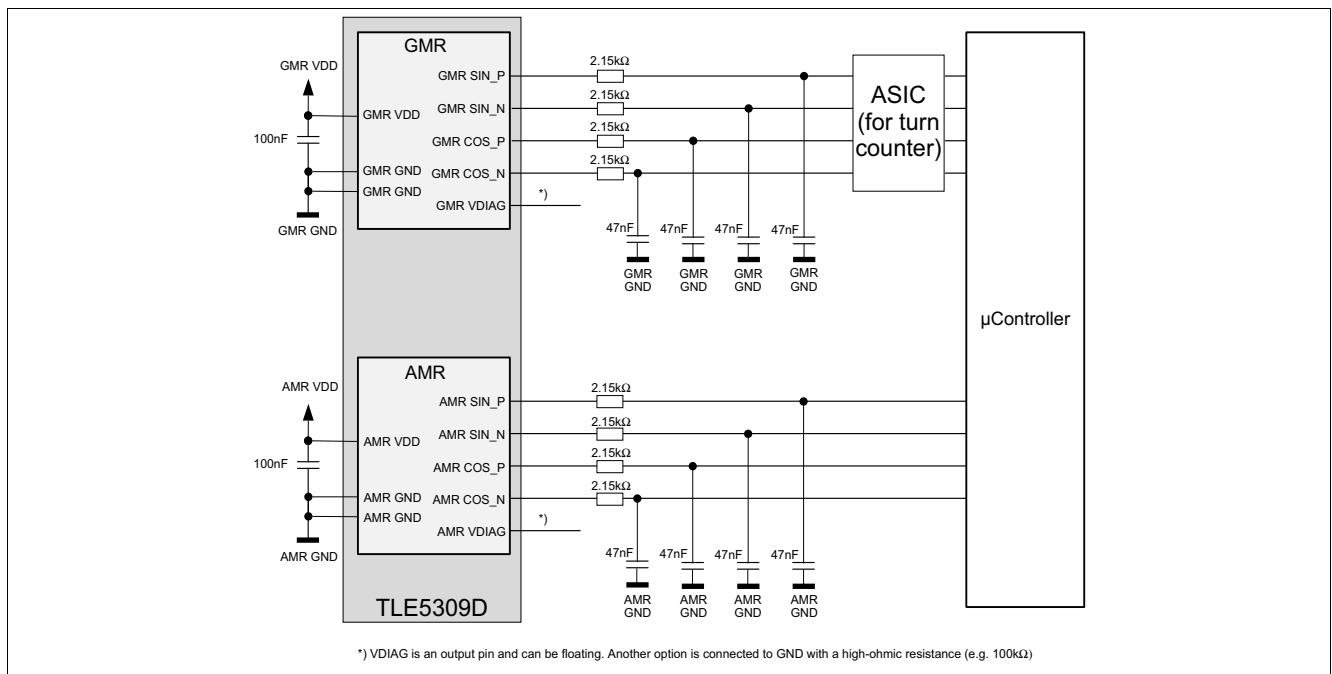

Figure 12 Application circuit for the TLE5309D in low-power applications in differential output mode (e.g. turn counter)

Pull-down resistors for partly diagnostics

It is also possible to use pull-down resistors to get partly diagnostics. With this setting it is not required to use the V_{DIAG} pin. The application circuit with pull-down resistors is shown in [Figure 13](#) for single-ended output respectively in [Figure 14](#) for differential output. For further details please refer to the [Safety Manual](#).

Specification

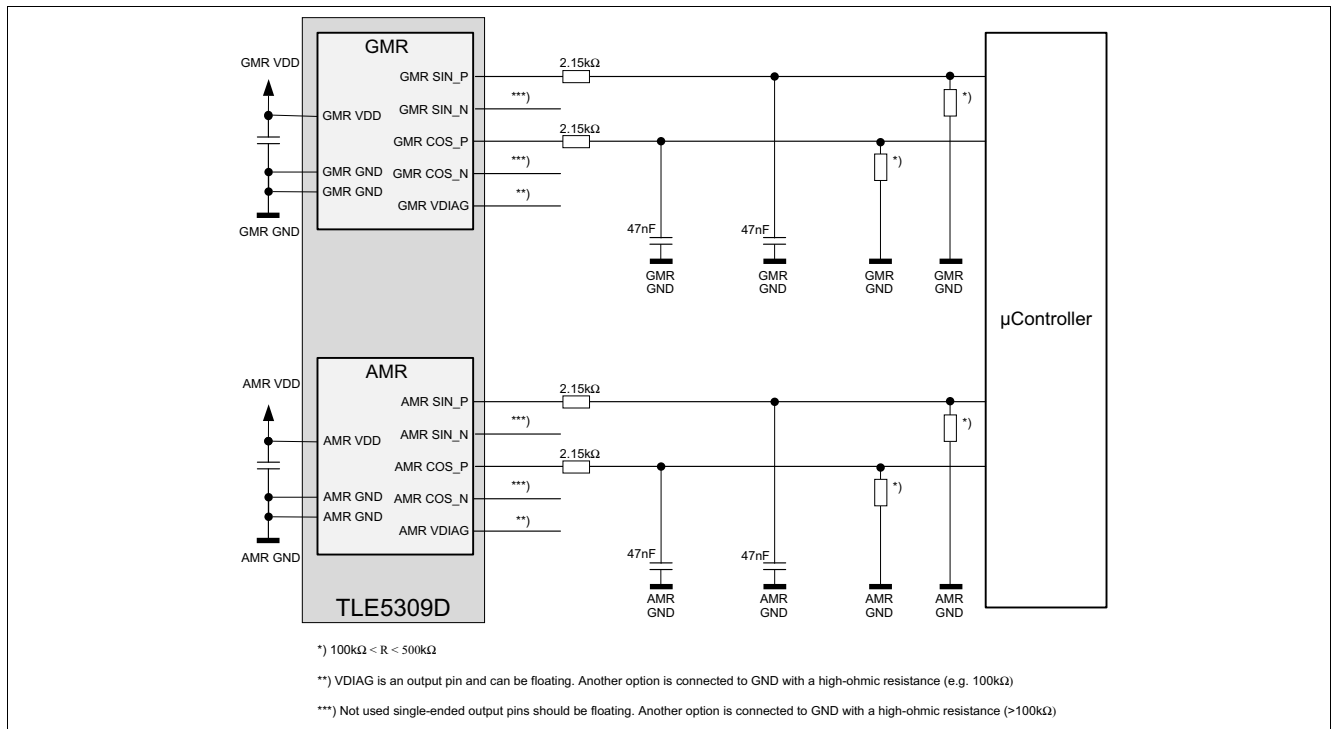

Figure 13 Application circuit for the TLE5309D for partial diagnostics with pull-down resistors in single-ended output mode; positive output channels used

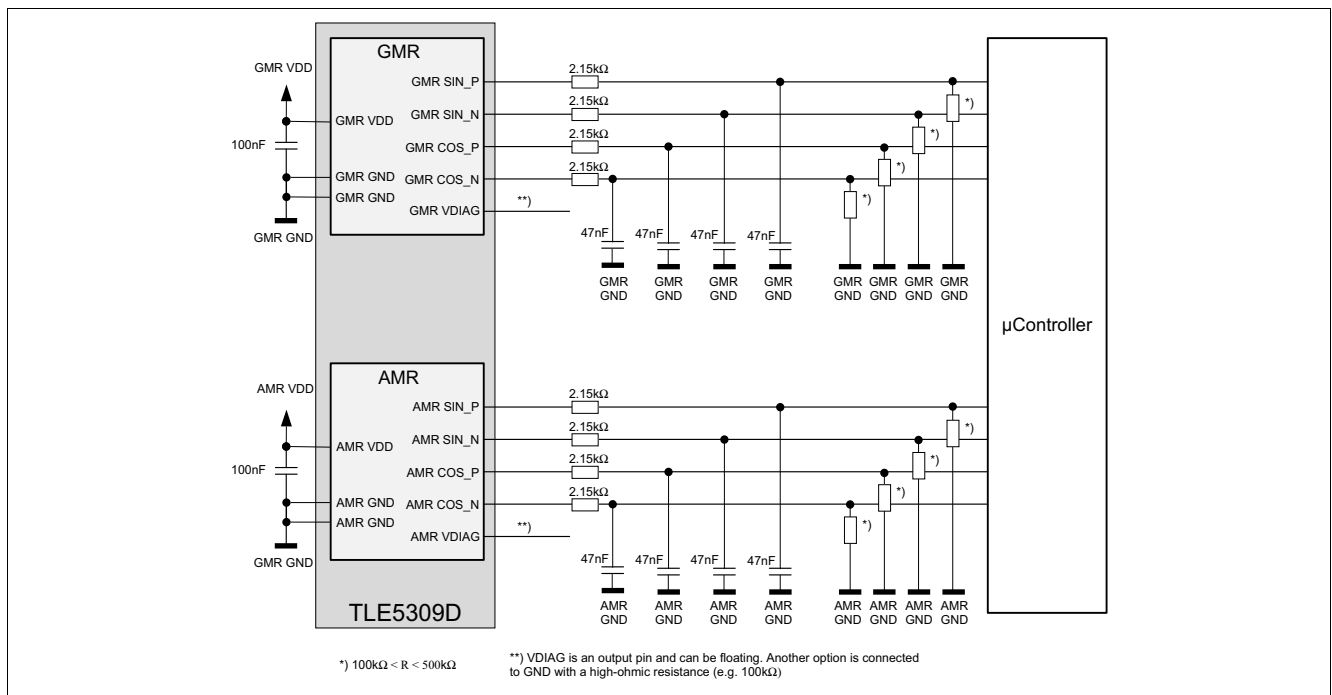

Figure 14 Application circuit for the TLE5309D for partial diagnostics with pull-down resistors in differential output mode

Specification

2.2 Absolute maximum ratings

Table 3 Absolute maximum ratings

Parameter	Symbol	Values			Unit	Note or Test Condition
		Min.	Typ.	Max.		
Supply voltage	V_{DD}	-0.5		6.5	V	Max. 40 h over lifetime
Ambient temperature ¹⁾	T_A	-40		140	°C	
Magnetic field induction	B			200	mT	Max. 5 min. at $T_A = 25^\circ\text{C}$
				150	mT	Max. 5 h at $T_A = 25^\circ\text{C}$

1) Assuming a thermal resistance of the sensor assembly in the application of 150 K/W or less.

Attention: *Stresses above the max. values listed here may cause permanent damage to the device. Exposure to absolute maximum rating conditions for extended periods may affect device reliability. Maximum ratings are absolute ratings; exceeding only one of these values may cause irreversible damage to the device.*

Specification

2.3 Sensor specification

The following operating conditions must not be exceeded in order to ensure correct operation of the TLE5309D.

All parameters specified in the following sections refer to these operating conditions, unless otherwise noted. [Table 4](#) is valid for $-40^{\circ}\text{C} < T_A < 125^{\circ}\text{C}$ and through the TLE5309D lifetime. Parameters are valid for AMR and GMR sensor, unless otherwise noted.

2.3.1 Operating range

Table 4 Operating range

Parameter	Symbol	Values			Unit	Note or Test Condition
		Min.	Typ.	Max.		
Ambient temperature ¹⁾	T_A	-40		125	$^{\circ}\text{C}$	
Supply voltage GMR ²⁾	$V_{DD, GMR}$	3.0	3.3	3.6	V	E5201, E1211
		4.5	5	5.5	V	E2211
Supply voltage AMR ²⁾	$V_{DD, AMR}$	3.0	3.3	3.6	V	E1211
		4.5	5	5.5	V	E5201, E2211
Output current ³⁾⁴⁾	I_Q	0		0.5	mA	COS_N; COS_P; SIN_N; SIN_P
		0		0.1	mA	V_{DIAG}
Load capacitance ³⁾⁵⁾	C_L	0		4.7	nF	All output pins
Magnetic field ³⁾⁶⁾⁷⁾⁸⁾	B_{XY}	24		60	mT	In X/Y direction, at $T_A = 25^{\circ}\text{C}$
		26		100	mT	In X/Y direction, at $T_A = -40^{\circ}\text{C}$
		21		50	mT	In X/Y direction, at $T_A = 125^{\circ}\text{C}$
Angle range	α	0		360	$^{\circ}$	(AMR is 180° -periodic, see Chapter 1.5)
Rotation speed ³⁾⁹⁾	n			30,000	rpm	
				150,000	rpm	No signal degradation observed in lab

- 1) Assuming a thermal resistance of the sensor assembly in the application of 150K/W or less.
- 2) Supply voltage V_{DD} buffered with 100 nF ceramic capacitor in close proximity to the sensor.
- 3) Not subject to production test - verified by design/characterization.
- 4) Assuming a symmetrical load.
- 5) Directly connected to the pin.
- 6) Values refer to a homogenous magnetic field (B_{XY}) without vertical magnetic induction ($B_Z = 0$ mT).
- 7) Min/Max values for magnetic field for intermediate temperatures can be obtained by linear interpolation.
- 8) Assuming a thermal resistance of the sensor assembly in the application of 150 K/W or less.
- 9) Typical angle propagation delay error is 1.62° at 30,000 rpm.

Specification

2.3.2 Electrical parameters

The indicated electrical parameters apply to the full operating range, unless otherwise specified. The typical values correspond to the specified supply voltage range and 25°C, unless individually specified. All other values correspond to $-40^{\circ}\text{C} < T_A < 125^{\circ}\text{C}$ and through the TLE5309D lifetime.

Table 5 Electrical parameters

Parameter	Symbol	Values			Unit	Note or Test Condition
		Min.	Typ.	Max.		
Supply current GMR	I_{DD}		7	10.5	mA	Without load on output pins
Supply current AMR			6	9.5	mA	Without load on output pins
POR level	V_{POR}	2.3	2.65	2.97	V	Power-On Reset
POR hysteresis ¹⁾	V_{PORhy}		50		mV	
Power-On time ²⁾	t_{PON}		40	70	μs	Settling time to 90% of full output voltages
Temperature reference voltage	V_{DIAG}	0.5	1.05	2.0	V	Temperature proportional output voltage; available on pin V_{DIAG}
Diagnostic function	V_{DIAG}	0		0.39	V	Diagnostic for internal errors; available on pin V_{DIAG}
Temperature coefficient of V_{DIAG} ¹⁾	TC_{VDIAG}		0.4		%/K	

1) Not subject to production test - verified by design/characterization.

2) Time measured at chip output pins.

2.3.3 Output parameters

All parameters apply over the full operating range, unless otherwise specified. The parameters in [Table 6](#) refer to single pin output and [Table 7](#) to differential output. For variable names please refer to [Figure 15 “GMR sensor single-ended output signals” on Page 18](#) and [Figure 17 “GMR differential output of ideal cosine” on Page 19](#).

The following equations describe various types of errors that combine to the overall angle error.

The maximum and zero-crossing of the SIN and COS signals do not occur at the precise angle of 90°. The difference between the X and Y phases is called the **orthogonality** error. In [Equation \(3\)](#) the angle at zero crossing of the X COS output is subtracted from the angle at the maximum of the Y SIN output, which describes the orthogonality of X and Y.

$$\varphi = \alpha[Y_{max}] - \alpha[X_0] \quad (3)$$

The amplitudes of SIN and COS signals are not equal to each other. The amplitude mismatch is defined as **synchronism**, shown in [Equation \(4\)](#). This value could also be described as amplitude ratio mismatch.

$$k = 100 * \frac{A_x}{A_y} \quad (4)$$

Specification

The sensor outputs 4 single-ended signals SIN_N, SIN_P, COS_N, and COS_P, which are centered at the voltage offset $0.5 \cdot V_{DD}$. The **differential signals** are calculated from the single-ended signals. The differential voltages for X or Y are defined in [Equation \(5\)](#).

$$\begin{aligned} V_{Xdiff} &= V_{COSP} - V_{COSN} \\ V_{Ydiff} &= V_{SINP} - V_{SINN} \end{aligned} \quad (5)$$

The maximum amplitudes for the differential signals are centered at 0 V and defined for X or Y as given in [Equation \(6\)](#):

$$\begin{aligned} A_{Xdiff} &= \frac{(X_{diff_MAX} - X_{diff_MIN})}{2} \\ A_{Ydiff} &= \frac{(Y_{diff_MAX} - Y_{diff_MIN})}{2} \end{aligned} \quad (6)$$

Differential offset of X or Y is defined in [Equation \(7\)](#).

$$\begin{aligned} O_{Xdiff} &= \frac{(X_{diff_MAX} + X_{diff_MIN})}{2} \\ O_{Ydiff} &= \frac{(Y_{diff_MAX} + Y_{diff_MIN})}{2} \end{aligned} \quad (7)$$

In **single-ended mode** the offset is defined as the mean output voltage and equals typically $0.5 \cdot V_{DD}$. For further details please refer to the application note [“TLE5009 Calibration”](#).

Table 6 Single-ended output parameters over temperature and lifetime

Parameter	Symbol	Values			Unit	Note or Test Condition
		Min.	Typ.	Max.		
X, Y amplitude	A_X, A_Y	0.7		1.3	V	Sensors with 3.3V supply
		1.2		1.95	V	Sensors with 5.0V supply
X, Y synchronism	k	94	100	106	%	GMR
		96	100	104	%	AMR
X, Y orthogonality error	ϕ	-12		12	°	GMR (AMR negligible)
Mean output voltage	V_{MVX}, V_{MYY}	$0.47 \cdot V_{DD}$	$0.5 \cdot V_{DD}$	$0.53 \cdot V_{DD}$	V	$V_{MV} = (V_{max} + V_{min}) / 2^{(1)}$
X, Y cut off frequency ²⁾	f_c		30		kHz	-3 dB attenuation
X, Y delay time ²⁾³⁾	t_{adel}		9		µs	
Output noise ²⁾	V_{Noise}		5		mV	RMS

1) V_{max} and V_{min} correspond to the voltage levels at X_{max} or Y_{max} and X_{min} or Y_{min} respectively as shown in [Figure 15](#), [Figure 16](#).

2) Not subject to production test - verified by design/characterization

3) Time measured at chip output pins.

Specification

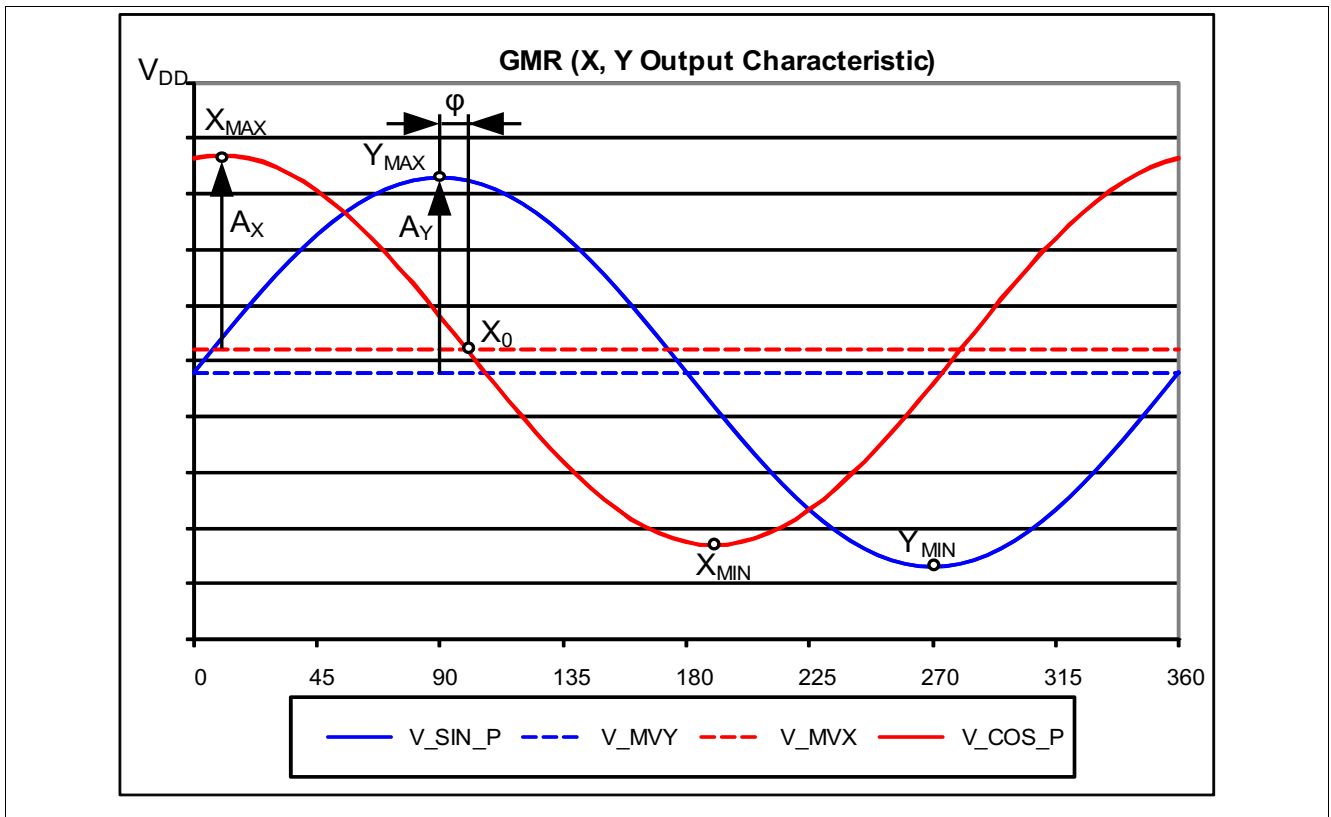

Figure 15 GMR sensor single-ended output signals

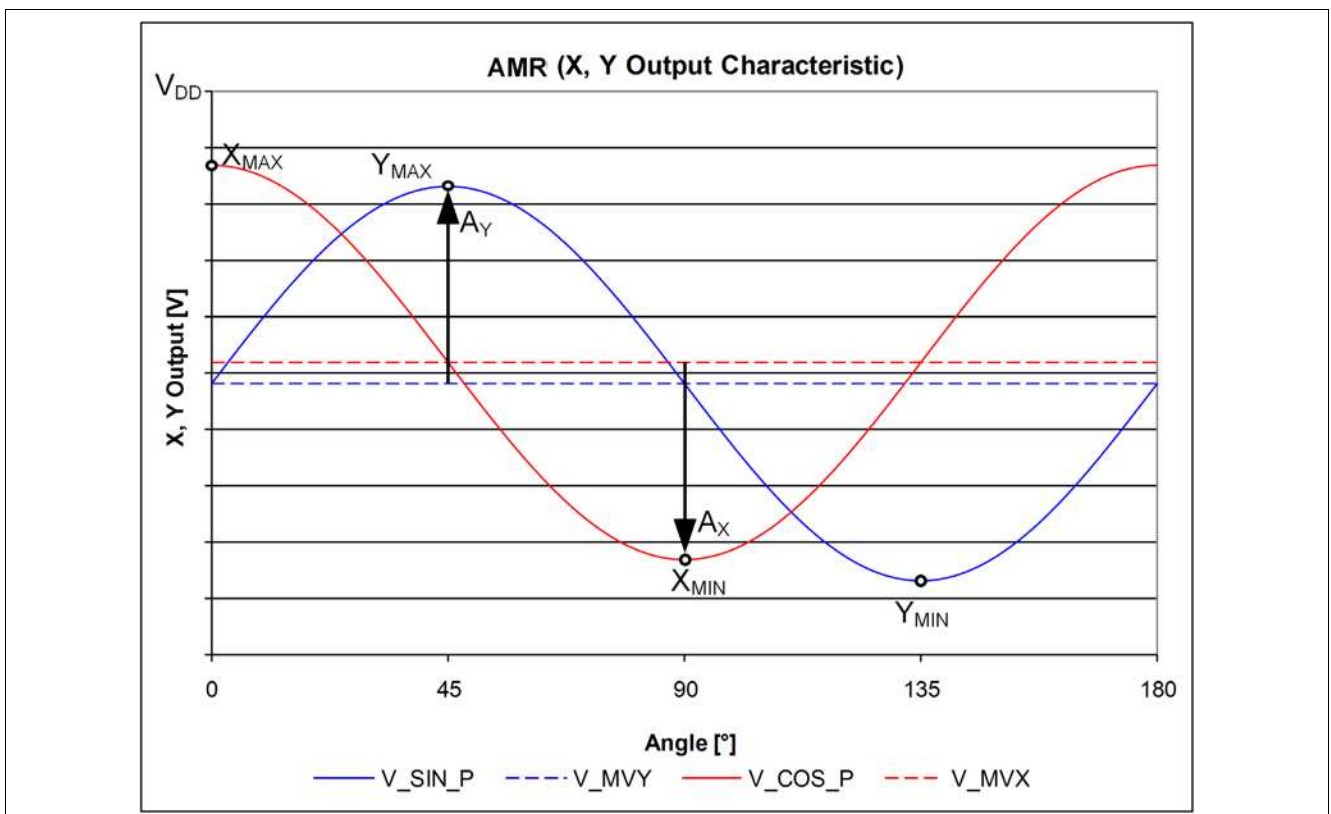

Figure 16 AMR sensor single-ended output signals

Specification

Table 7 Differential output parameters over temperature and lifetime

Parameter	Symbol	Values			Unit	Note or Test Condition
		Min.	Typ.	Max.		
X, Y amplitude	A_{Xdiff}, A_{Ydiff}	1.4		2.6	V	Sensors with 3.3 V supply
		2.4		3.9	V	Sensors with 5.0 V supply
X, Y synchronism	k	94	100	106	%	GMR
		96	100	104	%	AMR
X, Y orthogonality error	ϕ	-12		12	°	GMR (AMR negligible)
X, Y offset	O_{Xdiff}, O_{Ydiff}	-100	0	100	mV	GMR
		-200	0	200	mV	AMR
X, Y cut-off frequency ¹⁾	f_c		30		kHz	-3dB attenuation
X, Y delay time ¹⁾²⁾	t_{adel}		9		µs	
Vector Length ($V_{VEC} = \text{Sqrt}(X_{Diff}^2 + Y_{Diff}^2)$)	V_{VEC}	1.5		2.8		Sensors with 3.3 V supply
		2.5		3.9		Sensors with 5.0 V supply
Output noise ¹⁾	V_{Noise}		5		mV	RMS

- 1) Not subject to production test - verified by design/characterization.
- 2) Time measured at chip output pins.

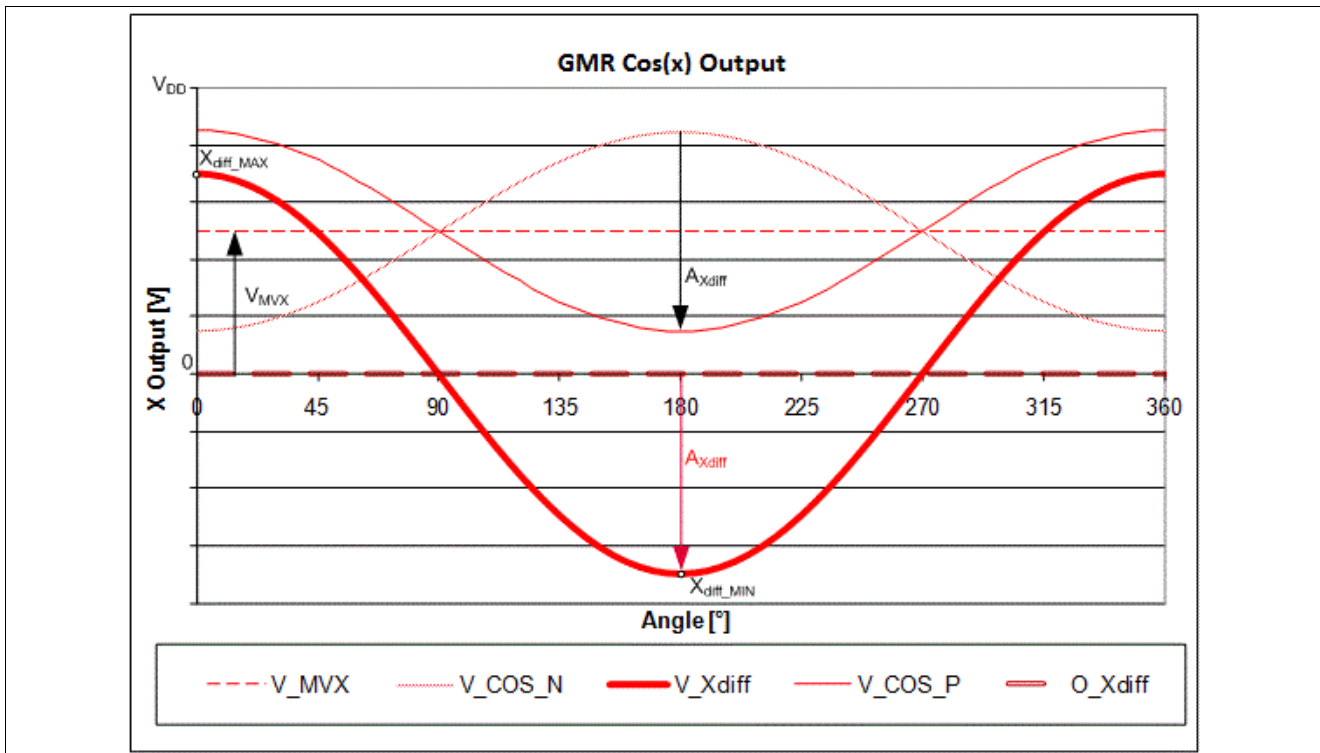

Figure 17 GMR differential output of ideal cosine

Specification

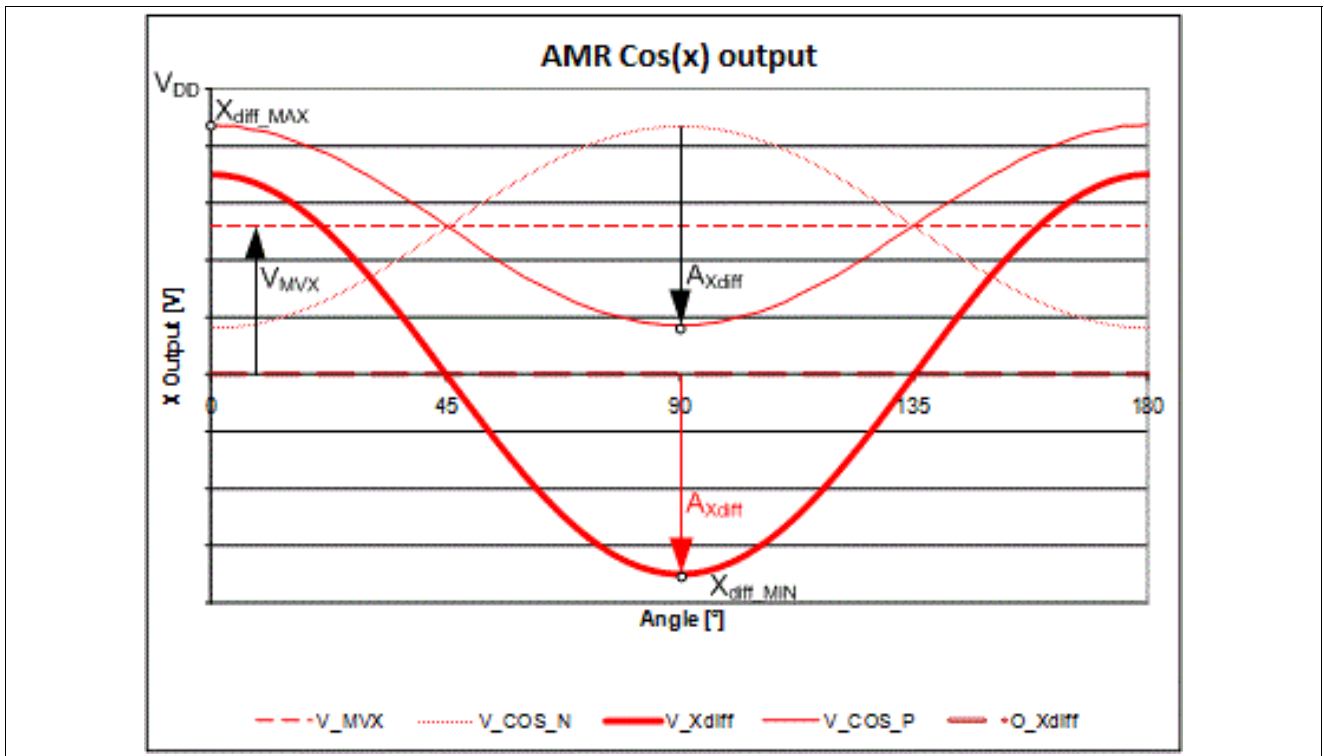

Figure 18 AMR differential output of ideal cosine

Specification

2.4 Error diagnosis

Each sensor provides two functions at its V_{DIAG} pin. During normal operation the voltage measured at this pin is temperature dependent. The typical voltage at room temperature and the temperature coefficient are given in [Table 5 “Electrical parameters” on Page 16](#).

The second purpose of pin V_{DIAG} is the diagnosis functionality. In case the device detects an internal error, the pin is driven to a low level. The errors that can be detected by monitoring the status of the V_{DIAG} pin are:

- Overvoltage at V_{DD} (supply)
- Undervoltage at V_{DD} (supply)
- Undervoltage at internal nodes (analog voltage regulator and/or GMR voltage regulator)
- Bandgap failure (temperature)
- Oscillator failure (only tested at startup)
- Parity check of configuration fuses (only tested at startup)

Not all the failure conditions that are detected by the V_{DIAG} pin are also detected by the alternative configuration with pull-down resistors described in [Figure 14](#). For further details please refer to the [Safety Manual](#).

2.5 Angle performance

The overall angle error represents the relative angular error. This error describes the deviation from the reference line after zero angle definition. The typical value corresponds to an ambient temperature of 25°C. All other values correspond to the operating ambient temperature range $-40^{\circ}\text{C} < T_A < 125^{\circ}\text{C}$ and through the TLE5309D lifetime.

Fully compensated performance

Using the algorithm described in the application note [“TLE5009 Calibration”](#), it is possible to implement an ongoing automatic calibration on the microcontroller to greatly improve the performance of the TLE5309D, as temperature and lifetime drifts are better compensated. This is only possible in applications where a rotor is turning continuously.

Table 8 Residual angle error over temperature and lifetime¹⁾

Parameter	Symbol	Values			Unit	Note or Test Condition
		Min.	Typ.	Max.		
Overall angle error AMR sensor (single-ended) ²⁾³⁾	α_{ERR}		0.1	0.5	°	
Overall angle error AMR sensor (differential) ²⁾	α_{ERR}		0.1	0.5	°	
Overall angle error GMR sensor (single-ended) ²⁾³⁾	α_{ERR}		< 0.6	0.9	°	
Overall angle error GMR sensor (differential) ²⁾	α_{ERR}		< 0.6	0.9	°	

1) After perfect compensation of offset, amplitude synchronicity mismatch and orthogonality error.

2) Including hysteresis error.

3) Assuming a symmetrical load.

With this auto calibration algorithm, it is possible to reach an angular accuracy as good as the residual error of the sensing elements, which means the remaining error after perfect compensation of offset and amplitude

Specification

synchronicity mismatch for both the AMR and the GMR sensors and perfect compensation of orthogonality error for the GMR sensor. A typical behavior of a fully compensated angle error with this ongoing calibration is shown in [Figure 19](#) for the GMR sensor and [Figure 20](#) for the AMR sensor for different ambient temperatures. The accuracy of the fully compensated angle is listed in [Table 8](#), which is divided into single-ended and differential output of the sensor.

Angle performance with one-time calibration

To achieve the overall angle error specified, both sensor ICs in the TLE5309D have to be calibrated for offset and amplitude synchronism at 25°C. Additionally, the GMR sensor has to be calibrated for orthogonality. The compensation parameters have to be stored and applied on the microcontroller. For the detailed calibration procedure refer to the application note “[TLE5009 Calibration](#)”. [Table 9](#) characterizes the accuracy of the angle, which is calculated from the single-ended output respectively the differential output of the sensor and the compensation parameters acquired in the end-of-line calibration.

Table 9 One-time calibrated angle error over temperature and lifetime

Parameter	Symbol	Values			Unit	Note or Test Condition
		Min.	Typ.	Max.		
Overall angle error AMR sensor (single-ended) ¹⁾²⁾	α_{ERR}			3.6	°	E5201
				2.4	°	E1211, E2211
Overall angle error AMR sensor (differential) ¹⁾	α_{ERR}			2.9	°	E5201
				1.7	°	E1211, E2211
Overall angle error GMR sensor (single-ended) ¹⁾²⁾	α_{ERR}			4.8	°	E5201
				4.0	°	E1211, E2211
Overall angle error GMR sensor (differential) ¹⁾	α_{ERR}			3.8	°	E5201
				3.0	°	E1211, E2211

1) Including hysteresis error.

2) Assuming a symmetrical load.

Typical behaviour of angle error compensation

The angle accuracy performance for ideal compensation and one-time compensation is listed in [Table 8](#) respectively in [Table 9](#). [Figure 19](#) shows for the GMR sensor and [Figure 20](#) for the AMR sensor the typical behavior of the residual angle error with ongoing respectively one-time calibration at different ambient temperatures. The comparison of this compensation algorithms demonstrates the superior performance of the full compensation method over lifetime and temperature with an average residual error below 0.6° for the GMR sensor and 0.1° for the AMR sensor operating in the specified magnetic field. With one-time compensation an additional residual angle error occurs due to the temperature dependency of the sensor.

Specification

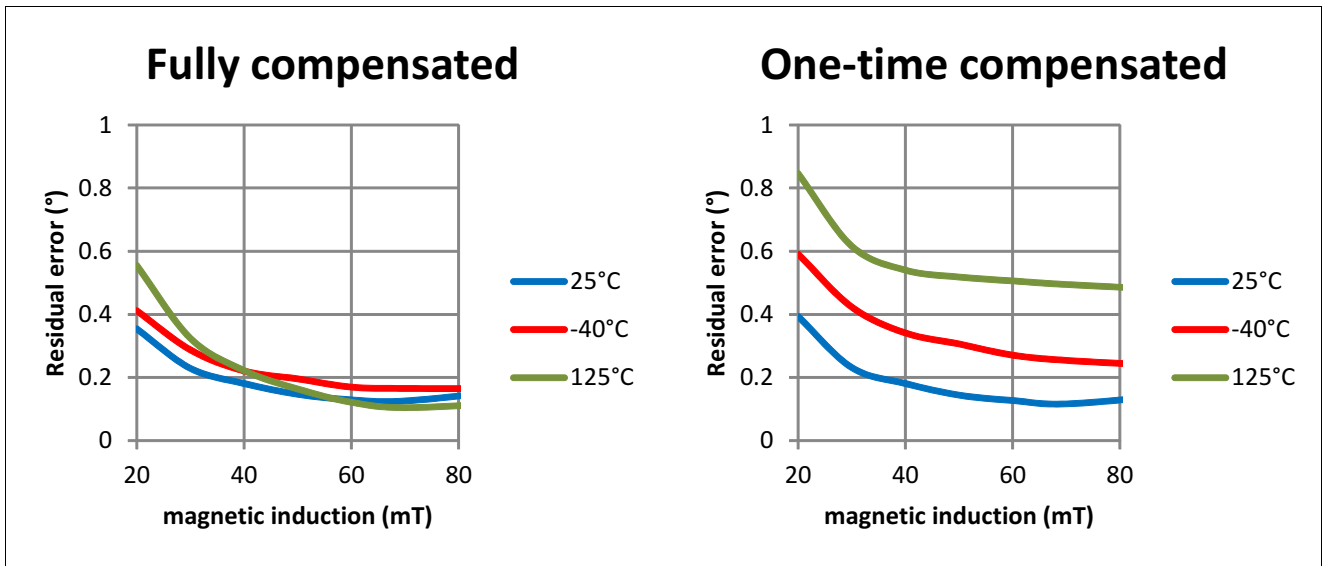

Figure 19 Typical residual angle error of fully and one-time compensated GMR sensor for differential output at different temperatures (measured at 0 h); one-time compensation is calibrated at $T = 25^{\circ}\text{C}$ and $B = 40 \text{ mT}$; TLE5309D derivative with TCO¹⁾ and 3.3 V supply voltage is used

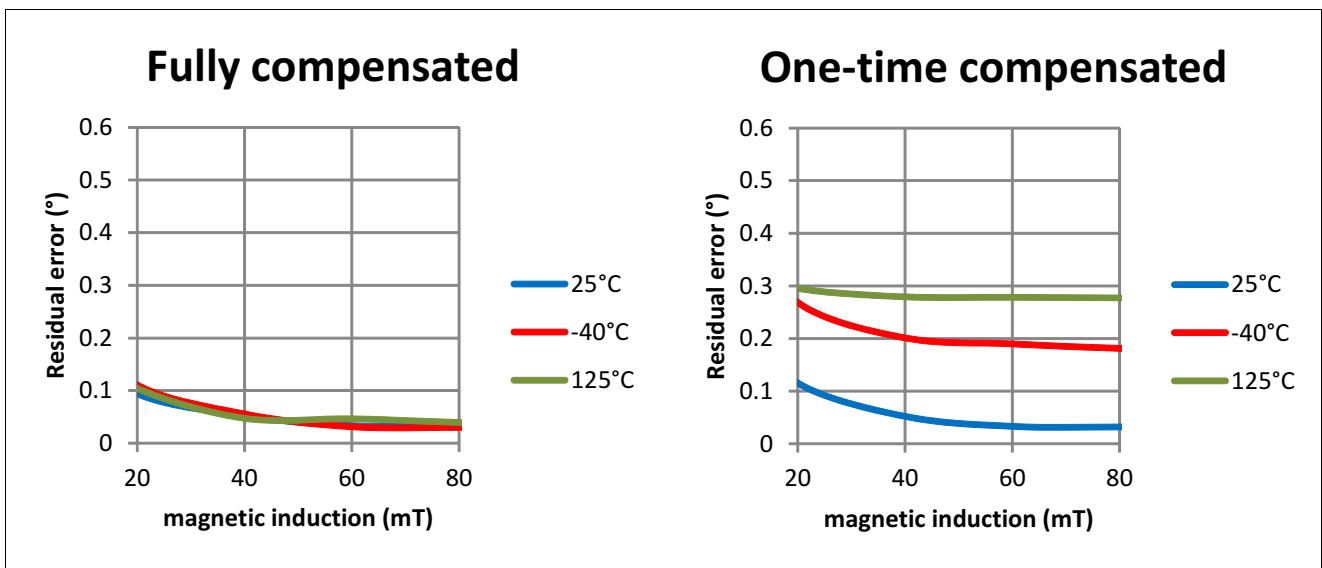

Figure 20 Typical residual angle error of fully and one-time compensated AMR sensor for differential output at different temperatures (measured at 0 h); one-time compensation is calibrated at $T = 25^{\circ}\text{C}$ and $B = 40 \text{ mT}$; TLE5309D derivative with TCO¹⁾ and 3.3 V supply voltage is used

1) Temperature Compensation Offset

Specification

2.6 Electrostatic discharge protection

Table 10 ESD protection

Parameter	Symbol	Values		Unit	Notes
		min.	max.		
ESD voltage	V_{HBM}		±4.0	kV	¹⁾ Ground pins connected.
			±2.0	kV	¹⁾
	V_{CDM}		±0.5	kV	²⁾
			±0.75	kV	²⁾ For corner pins.

1) Human Body Model (HBM) according to ANSI/ESDA/JEDEC JS-001.

2) Charged Device Model (CDM) according to JESD22-C101.

2.7 Electro magnetic compatibility (EMC)

The TLE5309D is characterized according to the EMC requirements described in the “Generic IC EMC Test Specification” Version 1.2 from November 15, 2007. The classification of the TLE5309D is done for local pins.

Package information

3 Package information

The TLE5309D is delivered in a green SMD package with lead-free plating, the PG-TDSO-16.

3.1 Package parameters

Table 11 Package parameters

Parameter	Symbol	Limit Values			Unit	Notes
		min.	typ.	max.		
Thermal Resistance	R_{thJA}		130	150	K/W	Junction-to-Air ¹⁾
	R_{thJC}			35	K/W	Junction-to-Case
	R_{thJL}			70	K/W	Junction-to-Lead
Moisture Sensitivity Level	MSL 3					260°C
Lead Frame	Cu					
Plating	Sn 100%					> 7 µm

1) According to Jedec JESD51-7

3.2 Package outlines

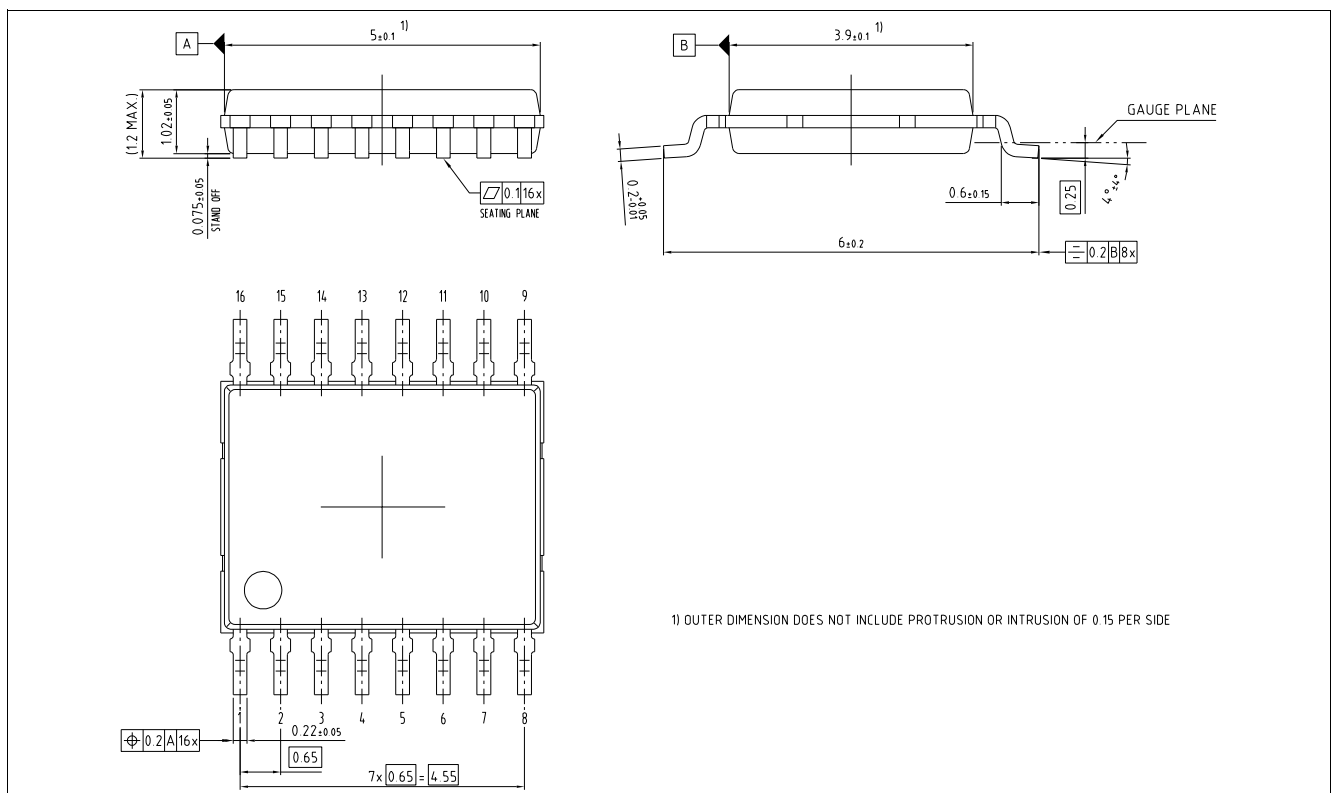

Figure 21 Package dimensions

Package information

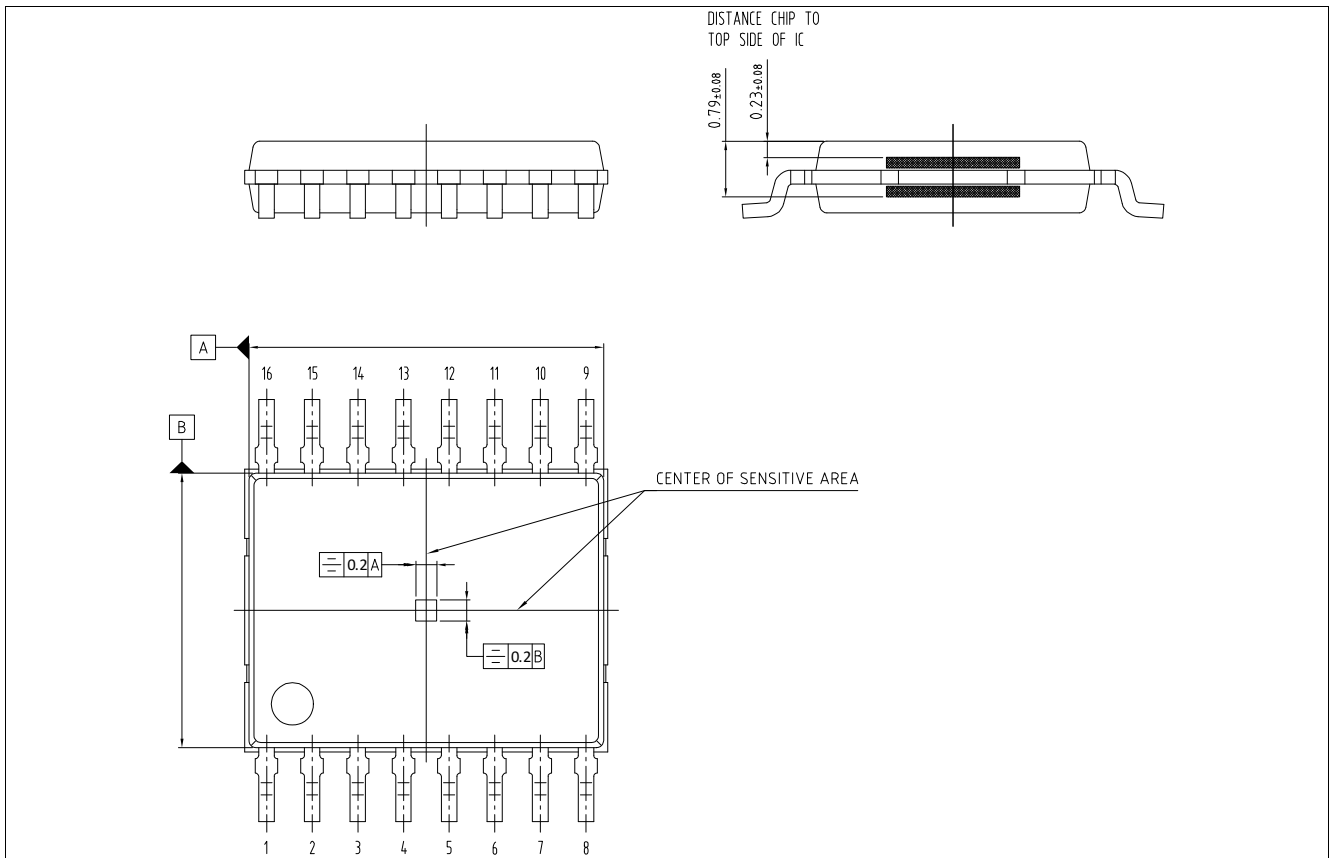

Figure 22 Position of sensing element

Table 12 Sensor IC placement tolerances in package

Parameter	Values		Unit	Notes
	Min.	Max.		
Position eccentricity	-100	100	μm	In X- and Y-direction
Rotation	-3	3	°	Affects zero position offset of sensor
Tilt	-3	3	°	

Package information

3.3 Footprint

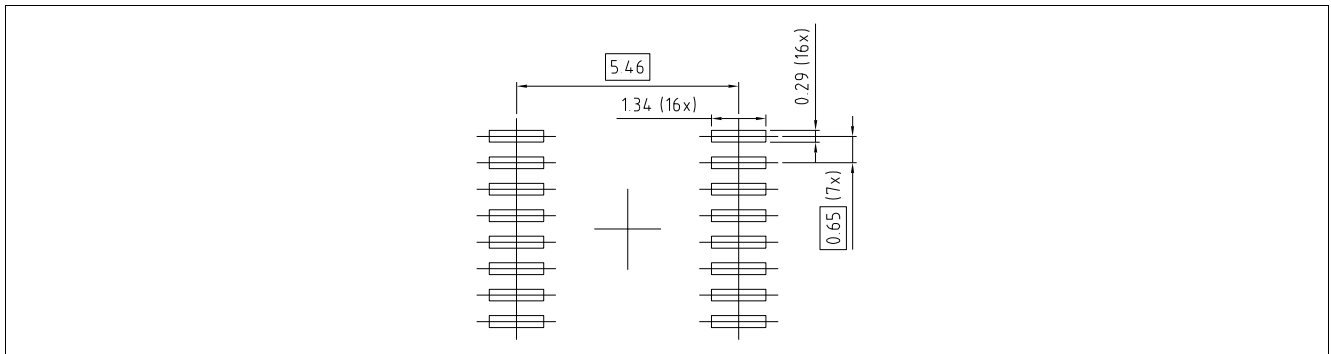

Figure 23 Footprint

3.4 Packing

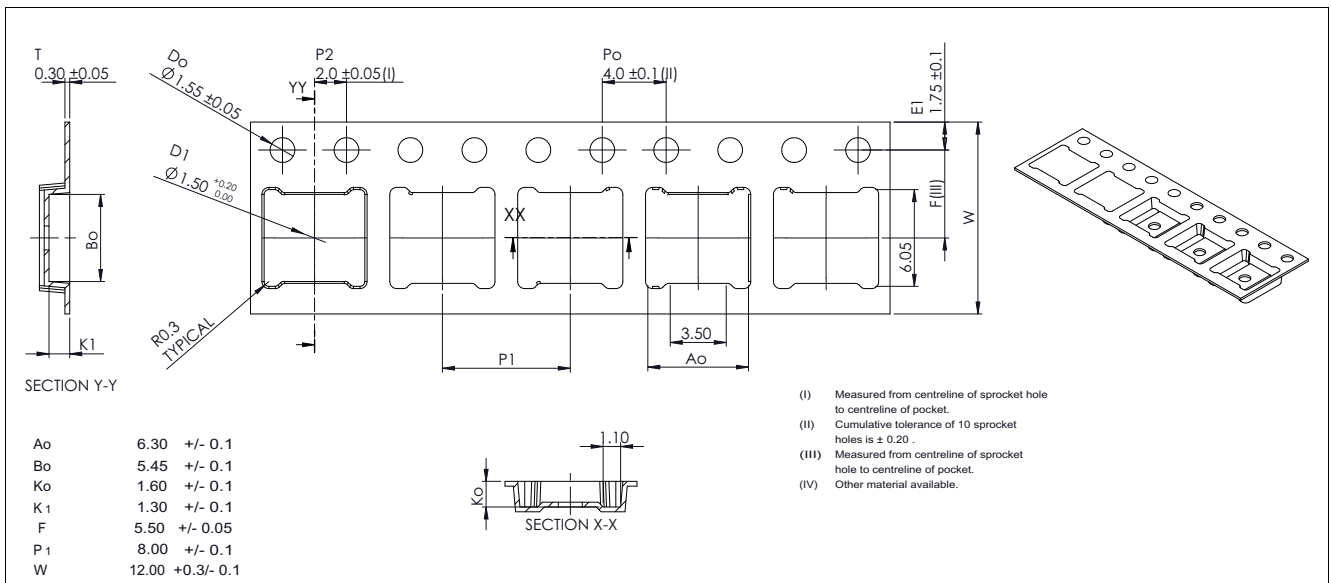

Figure 24 Tape and reel

Package information

3.5 Marking

The device is marked on the frontside with a date code, the device type and a lot code. On the backside there is a 8 x 18 data matrix code and an OCR-A code.

Position	Marking	Description
1st Line	Gxxxx	G = green, 4-digit = date code
2nd Line	309Dxxxx	Type (8 digits), see ordering Table 1
3rd Line	xxx	Lot code (3 digits)

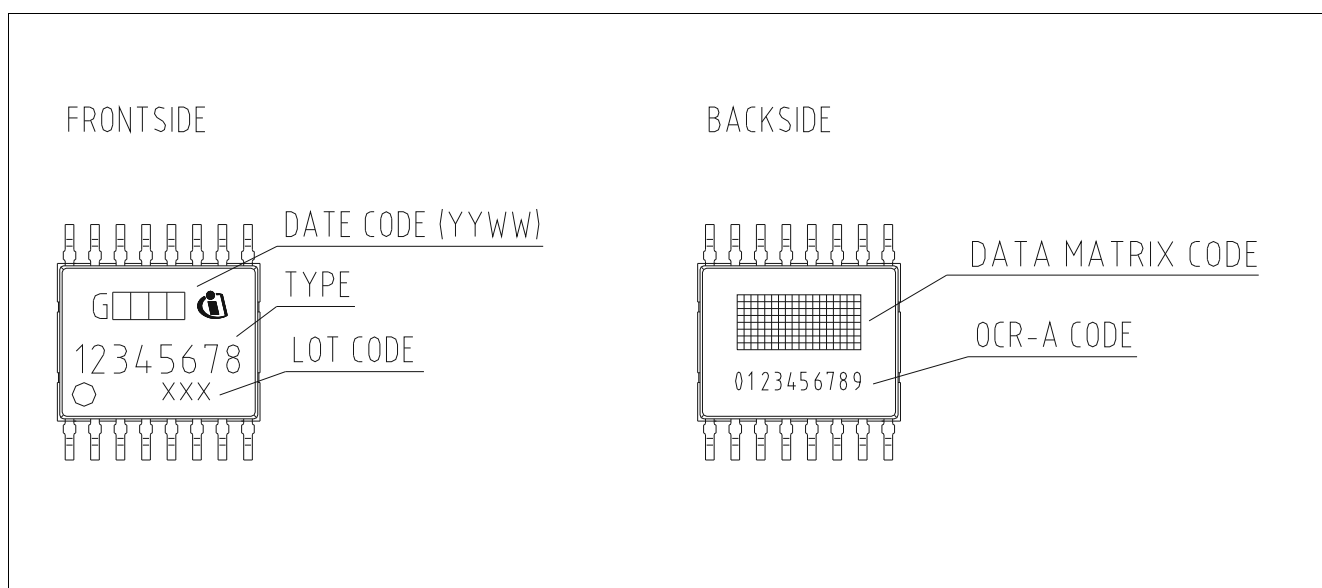

Figure 25 Marking

Revision history

4 Revision history

Revision	Date	Changes
1.0	2016-01	Initial release
1.1	2017-10	Layout changed Table 8: single-ended angle error added Table 9: single-ended angle error added Figure 19: Typical residual angle error for full and one-time compensation GMR sensor added Figure 20: Typical residual angle error for full and one-time compensation AMR sensor added Chapter References removed Pin description: Symbol changed to Pin Name Figure 9: Application circuit in single-ended output mode added Figure 11: Application circuit in low-power applications in single-ended output mode added Figure 13: Application circuit for partial diagnostics with pull-down resistors in single-ended output mode added

Trademarks of Infineon Technologies AG

μHVIC™, μIPM™, μPFC™, AU-ConvertIR™, AURIX™, C166™, CanPAK™, CIPOS™, CIPURSE™, CoolDP™, CoolGaN™, COOLiR™, CoolMOS™, CoolSET™, CoolSiC™, DAVE™, DI-POL™, DirectFET™, DrBlade™, EasyPIM™, EconoBRIDGE™, EconoDUAL™, EconoPACK™, EconoPIM™, EiceDRIVER™, eupec™, FCOS™, GaNpowIR™, HEXFET™, HITFET™, HybridPACK™, iMOTION™, IRAM™, ISOFACE™, IsoPACK™, LEDriviR™, LITIX™, MIPAQ™, ModSTACK™, my-d™, NovalithIC™, OPTIGA™, OptiMOS™, ORIGA™, PowIRaudio™, PowIRstage™, PrimePACK™, PrimeSTACK™, PROFET™, PRO-SIL™, RASIC™, REAL3™, SmartLEWIS™, SOLID FLASH™, SPOC™, StrongIRFET™, SupIRBuck™, TEMPFET™, TRENCHSTOP™, TriCore™, UHVIC™, XHP™, XMC™.

Trademarks updated November 2015

Other Trademarks

All referenced product or service names and trademarks are the property of their respective owners.

Edition 2017-10

Published by

Infineon Technologies AG

81726 Munich, Germany

© 2017 Infineon Technologies AG.

All Rights Reserved.

Do you have a question about any aspect of this document?

Email: erratum@infineon.com

IMPORTANT NOTICE

The information given in this document shall in no event be regarded as a guarantee of conditions or characteristics ("Beschaffheitsgarantie").

With respect to any examples, hints or any typical values stated herein and/or any information regarding the application of the product, Infineon Technologies hereby disclaims any and all warranties and liabilities of any kind, including without limitation warranties of non-infringement of intellectual property rights of any third party.

In addition, any information given in this document is subject to customer's compliance with its obligations stated in this document and any applicable legal requirements, norms and standards concerning customer's products and any use of the product of Infineon Technologies in customer's applications.

The data contained in this document is exclusively intended for technically trained staff. It is the responsibility of customer's technical departments to evaluate the suitability of the product for the intended application and the completeness of the product information given in this document with respect to such application.

For further information on technology, delivery terms and conditions and prices, please contact the nearest Infineon Technologies Office (www.infineon.com).

WARNINGS

Due to technical requirements products may contain dangerous substances. For information on the types in question please contact your nearest Infineon Technologies office.

Except as otherwise explicitly approved by Infineon Technologies in a written document signed by authorized representatives of Infineon Technologies, Infineon Technologies' products may not be used in any applications where a failure of the product or any consequences of the use thereof can reasonably be expected to result in personal injury.