

## 16-Channel, Constant-Current LED Driver with Pre-Charge FET

Check for Samples: [TLC59283](#)

### FEATURES

- 16-Channel, Constant-Current Sink Output with On and Off Control
- Constant-Current Sink Capability: 35 mA ( $V_{CC} \leq 3.6$  V), 45 mA ( $V_{CC} > 3.6$  V)
- LED Power-Supply Voltage: Up to 10 V
- $V_{CC} = 3$  V to 5.5 V
- Constant-Current Accuracy:
  - Channel-to-Channel:  $\pm 1.4\%$  (typ),  $\pm 3\%$  (max)
  - Device-to-Device:  $\pm 2\%$  (typ),  $\pm 4\%$  (max)
- CMOS Logic Level I/O
- Data Transfer Rate: 35 MHz
- BLANK Pulse Width: 50 ns
- Pre-Charge FET for Ghosting Reduction
- Grouped Switching Delay for Noise Reduction
- Operating Temperature:  $-40^{\circ}\text{C}$  to  $+85^{\circ}\text{C}$

### APPLICATIONS

- Video Displays
- Message Boards

### DESCRIPTION

The TLC59283 is a 16-channel, constant-current sink light-emitting diode (LED) driver. Each channel can be individually controlled with a simple serial communications protocol that is compatible with 3.3-V or 5-V CMOS logic levels, depending on the operating VCC. When the serial data buffer is loaded, a LAT rising edge transfers the data to the OUT $n$  outputs. The BLANK pin can be used to turn off all OUT $n$  outputs during power-on and output data latching to prevent unwanted image displays during these times. The constant-current value of all 16 channels is set by a single external resistor.

Each constant-current output has a pre-charge field-effect transistor (FET) that can reduce ghosting on the multiplexing (dynamic) drive LED display. Multiple TLC59283s can be cascaded together to control additional LEDs from the same processor.

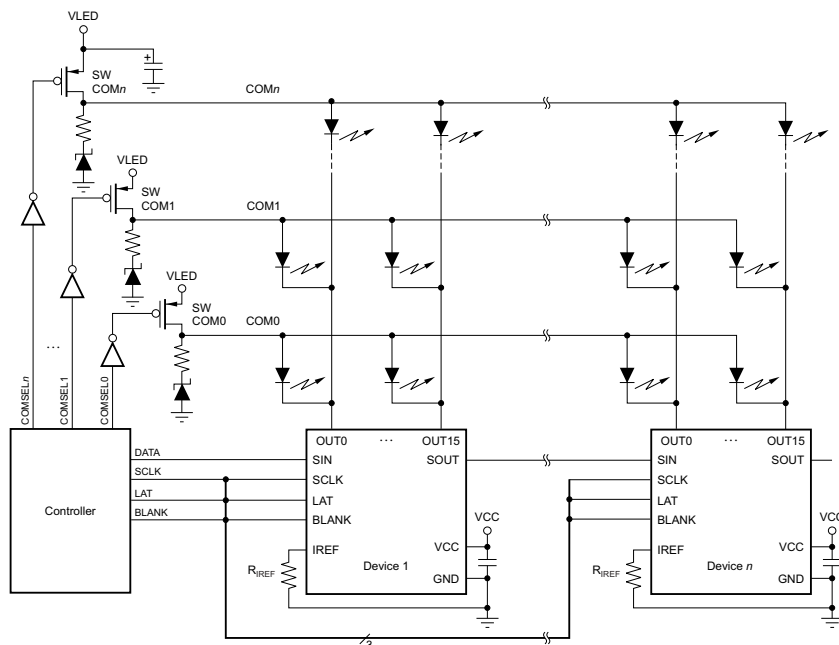

Typical Application Circuit (Multiple Daisy-Chainned TLC59283s)



Please be aware that an important notice concerning availability, standard warranty, and use in critical applications of Texas Instruments semiconductor products and disclaimers thereto appears at the end of this data sheet.

All trademarks are the property of their respective owners.



This integrated circuit can be damaged by ESD. Texas Instruments recommends that all integrated circuits be handled with appropriate precautions. Failure to observe proper handling and installation procedures can cause damage.

ESD damage can range from subtle performance degradation to complete device failure. Precision integrated circuits may be more susceptible to damage because very small parametric changes could cause the device not to meet its published specifications.

### PACKAGE AND ORDERING INFORMATION<sup>(1)</sup>

PRODUCT	PACKAGE-LEAD	ORDERING NUMBER	TRANSPORT MEDIA, QUANTITY
TLC59283	SSOP-24 and QSOP-24	TLC59283DBQR	Tape and Reel, 2500
		TLC59283DBQ	Tube, 50
TLC59283	QFN-24	TLC59283RGER	Tape and Reel, 3000
		TLC59283RGE	Tape and Reel, 250

(1) For the most current package and ordering information, see the Package Option Addendum at the end of this document, or visit the device product folder at [www.ti.com](http://www.ti.com).

### ABSOLUTE MAXIMUM RATINGS<sup>(1)(2)</sup>

Over operating free-air temperature range, unless otherwise noted.

			VALUE		UNIT
			MIN	MAX	
Voltage	V <sub>CC</sub>	Supply	-0.3	+6	V
	V <sub>IN</sub>	Input range, SIN, SCLK, LAT, BLANK, IREF	-0.3	V <sub>CC</sub> + 0.3	V
	V <sub>OUT</sub>	Output range, SOUT	-0.3	V <sub>CC</sub> + 0.3	V
		Output range, OUT0 to OUT15	-0.3	+11	V
Current	I <sub>OUT</sub>	Output (dc), OUT0 to OUT15		+50	mA
Temperature	T <sub>J(MAX)</sub>	Operating junction		+150	°C
	T <sub>stg</sub>	Storage range	-55	+150	°C
Electrostatic discharge ratings	ESD	Human body model (HBM)		3000	V
		Charged device model (CDM)		2000	V

(1) Stresses above these ratings may cause permanent damage. Exposure to absolute maximum conditions for extended periods may degrade device reliability. These are stress ratings only, and functional operation of the device at these or any other conditions beyond those specified is not supported.

(2) All voltage values are with respect to network ground terminal.

### THERMAL INFORMATION

THERMAL METRIC <sup>(1)</sup>		TLC59283		UNITS
		DBQ	RGE	
		24 PINS	24 PINS	
θ <sub>JA</sub>	Junction-to-ambient thermal resistance	91.5	42.9	°C/W
θ <sub>JCtop</sub>	Junction-to-case (top) thermal resistance	55.2	55.3	
θ <sub>JB</sub>	Junction-to-board thermal resistance	44.9	21.7	
ψ <sub>JT</sub>	Junction-to-top characterization parameter	16.8	1.9	
ψ <sub>JB</sub>	Junction-to-board characterization parameter	44.5	21.8	
θ <sub>JCbot</sub>	Junction-to-case (bottom) thermal resistance	N/A	8.8	

(1) For more information about traditional and new thermal metrics, see the *IC Package Thermal Metrics* application report, [SPRA953](http://www.ti.com/lit/zip/SRPA953).

## RECOMMENDED OPERATING CONDITIONS

 At  $T_A = -40^{\circ}\text{C}$  to  $+85^{\circ}\text{C}$ , unless otherwise noted.

PARAMETER			TEST CONDITIONS	TLC59283		UNIT
				MIN	MAX	
<b>DC CHARACTERISTICS (<math>V_{CC} = 3\text{ V to }5.5\text{ V}</math>)</b>						
$V_{CC}$	Supply voltage			3	5.5	V
$V_O$	Voltage applied to output		OUT0 to OUT15		10	V
$V_{IH}$	Input voltage	High	SIN, SCLK, LAT, BLANK	$0.7 \times V_{CC}$	$V_{CC}$	V
$V_{IL}$		Low	SIN, SCLK, LAT, BLANK	GND	$0.3 \times V_{CC}$	V
$I_{OH}$	Output current	High	SOUT		-2	mA
$I_{OL}$		Low	SOUT		2	mA
$I_{OLC}$	Constant output sink current		OUT0 to OUT15, $3\text{ V} \leq V_{CC} \leq 3.6\text{ V}$	2	35	mA
			OUT0 to OUT15, $3.6\text{ V} < V_{CC} \leq 5.5\text{ V}$	2	45	mA
$T_A$	Temperature range	Operating free-air		-40	+85	$^{\circ}\text{C}$
$T_J$		Operating junction		-40	+125	$^{\circ}\text{C}$
<b>AC CHARACTERISTICS (<math>V_{CC} = 3\text{ V to }5.5\text{ V}</math>)</b>						
$f_{CLK}$ (SCLK)	Data shift clock frequency		SCLK		35	MHz
$t_{WH0}$	Pulse duration		SCLK	10		ns
$t_{WL0}$			SCLK	10		ns
$t_{WH1}$			LAT	20		ns
$t_{WH2}$			BLANK	100		ns
$t_{WL2}$			BLANK	50		ns
$t_{SU0}$			Setup time	SIN $\uparrow$ – SCLK $\uparrow$	4	
$t_{SU1}$	LAT $\downarrow$ – SCLK $\uparrow$	10			ns	
$t_{H0}$	Hold time	SIN $\uparrow$ – SCLK $\uparrow$	4		ns	
$t_{H1}$		LAT $\downarrow$ – SCLK $\uparrow$	10		ns	

## ELECTRICAL CHARACTERISTICS

All minimum and maximum specifications are at  $T_A = -40^\circ\text{C}$  to  $+85^\circ\text{C}$  and  $V_{CC} = 3\text{ V}$  to  $5.5\text{ V}$ , unless otherwise noted. Typical specifications are at  $T_A = +25^\circ\text{C}$  and  $V_{CC} = 3.3\text{ V}$ .

PARAMETER			TEST CONDITIONS	TLC59283			UNIT	
				MIN	TYP	MAX		
$V_{OH}$	Output voltage	High	$I_{OH} = -2\text{ mA}$ at SOUT	$V_{CC} - 0.4$		$V_{CC}$	V	
$V_{OL}$		Low	$I_{OL} = 2\text{ mA}$ at SOUT			0.4	V	
$V_{PCHG}$	Pre-charged voltage		$I_O = -10\text{ }\mu\text{A}$	$V_{CC} - 2.0$	$V_{CC} - 1.4$	$V_{CC} - 0.8$	V	
$V_{IREF}$	Reference voltage output		$R_{IREF} = 1.5\text{ k}\Omega$ , $T_A = +25^\circ\text{C}$	1.208			V	
$I_{IN}$	Input current		$V_{IN} = V_{CC}$ or GND at SIN and SCLK	-1		1	$\mu\text{A}$	
$I_{CC0}$	Supply current ( $V_{CC}$ )		SIN, SCLK, LAT = GND, BLANK = $V_{OUTn} = V_{CC}$ , $R_{IREF} = \text{open}$		1	2	mA	
$I_{CC1}$			SIN, SCLK, LAT = GND, BLANK = $V_{OUTn} = V_{CC}$ , $R_{IREF} = 3\text{ k}\Omega$ ( $I_{OUT} = 17.6\text{ mA}$ target)		3	4	mA	
$I_{CC2}$			All $OUTn = \text{ON}$ , SIN, SCLK, LAT, BLANK = GND, $V_{OUTn} = 0.8\text{ V}$ , $R_{IREF} = 3\text{ k}\Omega$		7	9	mA	
$I_{CC3}$			All $OUTn = \text{ON}$ , SIN, SCLK, LAT, BLANK = GND, $V_{OUTn} = 0.8\text{ V}$ , $R_{IREF} = 1.5\text{ k}\Omega$ ( $I_{OUT} = 35.3\text{ mA}$ target)		8	11	mA	
$I_{OLC}$	Constant output current		All $OUTn = \text{ON}$ , $V_{OUTn} = V_{OUTfix} = 0.8\text{ V}$ , $R_{IREF} = 1.5\text{ k}\Omega$ , $T_A = +25^\circ\text{C}$ (see Figure 8)	32.9	35.3	37.7	mA	
$I_{OLKG0}$	Output leakage current		All $OUTn = \text{OFF}$ , $V_{OUTn} = V_{OUTfix} = 10\text{ V}$ , BLANK = $V_{CC}$ , $R_{IREF} = 1.5\text{ k}\Omega$ (see Figure 8)					
				$T_J = +25^\circ\text{C}$		0.1	$\mu\text{A}$	
				$T_J = +85^\circ\text{C}$		0.2	$\mu\text{A}$	
			$T_J = +125^\circ\text{C}$	0.07	0.5	$\mu\text{A}$		
$\Delta I_{OLC0}$	Constant-current error	Channel-to-channel <sup>(1)</sup>	All $OUTn = \text{ON}$ , $V_{OUTn} = V_{OUTfix} = 0.8\text{ V}$ , $R_{IREF} = 1.5\text{ k}\Omega$ , $T_A = +25^\circ\text{C}$ (see Figure 8)	$\pm 1.4$			$\pm 3$	%
$\Delta I_{OLC1}$		Device-to-device <sup>(2)</sup>	All $OUTn = \text{ON}$ , $V_{OUTn} = V_{OUTfix} = 0.8\text{ V}$ , $R_{IREF} = 1.5\text{ k}\Omega$ , $T_A = +25^\circ\text{C}$ (see Figure 8)	$\pm 2$			$\pm 4$	%
$\Delta I_{OLC2}$	Line regulation <sup>(3)</sup>		All $OUTn = \text{ON}$ , $V_{OUTn} = V_{OUTfix} = 0.8\text{ V}$ , $R_{IREF} = 1.5\text{ k}\Omega$ , $V_{CC} = 3\text{ V}$ to $5.5\text{ V}$	$\pm 0.05$			$\pm 1$	%/V
$\Delta I_{OLC3}$	Load regulation <sup>(4)</sup>		All $OUTn = \text{ON}$ , $V_{OUTn} = 0.8\text{ V}$ to $3\text{ V}$ , $V_{OUTfix} = 0.8\text{ V}$ , $R_{IREF} = 1.5\text{ k}\Omega$	$\pm 0.5$			$\pm 1$	%/V
$R_{PUP}$	Resistor	Pull-up	BLANK	250	500	750	k $\Omega$	
$R_{PDWN}$		Pull-down	LAT	250	500	750	k $\Omega$	
$R_{PCHG}$	Pre-charge FET on-resistance		$V_{CC} = 5.0\text{ V}$ , $V_{OUTn} = 0\text{ V}$ , OUT0 to OUT15, BLANK = $V_{CC}$ , $T_A = +25^\circ\text{C}$		3	6	k $\Omega$	

- (1) The deviation of each output from the average of OUT0 to OUT15 constant-current. Deviation is calculated by the formula:

$$\Delta (\%) = \left[ \frac{I_{OUTn}}{\frac{(I_{OUT0} + I_{OUT1} + \dots + I_{OUT14} + I_{OUT15})}{16}} - 1 \right] \times 100$$

- (2) The deviation of the OUT0 to OUT15 constant-current average from the ideal constant-current value. Deviation is calculated by the following formula:

$$\Delta (\%) = \left[ \frac{\frac{(I_{OUT0} + I_{OUT1} + \dots + I_{OUT14} + I_{OUT15})}{16} - (\text{Ideal Output Current})}{\text{Ideal Output Current}} \right] \times 100$$

Ideal current is calculated by the formula:

$$I_{OUT(\text{IDEAL})} = 43.8 \times \left[ \frac{1.208\text{ V}}{R_{IREF}} \right]$$

- (3) Line regulation is calculated by this equation:

$$\Delta (\%/V) = \left[ \frac{(I_{OUTn} \text{ at } V_{CC} = 5.5\text{ V}) - (I_{OUTn} \text{ at } V_{CC} = 3\text{ V})}{(I_{OUTn} \text{ at } V_{CC} = 3\text{ V})} \right] \times \frac{100}{5.5\text{ V} - 3\text{ V}}$$

- (4) Load regulation is calculated by the equation:

$$\Delta (\%/V) = \left[ \frac{(I_{OUTn} \text{ at } V_{OUTn} = 3\text{ V}) - (I_{OUTn} \text{ at } V_{OUTn} = 1\text{ V})}{(I_{OUTn} \text{ at } V_{OUTn} = 1\text{ V})} \right] \times \frac{100}{3\text{ V} - 1\text{ V}}$$

## SWITCHING CHARACTERISTICS

All minimum and maximum specifications are at  $T_A = -40^{\circ}\text{C}$  to  $+85^{\circ}\text{C}$ ,  $V_{CC} = 3\text{ V}$  to  $5.5\text{ V}$ ,  $C_L = 15\text{ pF}$ ,  $R_L = 110\ \Omega$ ,  $R_{IREF} = 1.5\text{ k}\Omega$ , and  $V_{LED} = 5.0\text{ V}$ , unless otherwise noted. Typical values are at  $T_A = +25^{\circ}\text{C}$  and  $V_{CC} = 3.3\text{ V}$ .

PARAMETER	TEST CONDITIONS	TLC59283			UNIT	
		MIN	TYP	MAX		
$t_{R0}$	Rise time SOUT (see Figure 7)		3	10	ns	
$t_{R1}$		OUT $n$ (see Figure 6)		44		ns
$t_{F0}$	Fall time SOUT (see Figure 7)		3	10	ns	
$t_{F1}$		OUT $n$ (see Figure 6)		44		ns
$t_{D0}$	Propagation delay time SCLK $\uparrow$ to SOUT $\uparrow\downarrow$		11	20	ns	
$t_{D1}$		LAT $\uparrow$ or BLANK $\uparrow\downarrow$ to OUT0 on or off, $T_A = +25^{\circ}\text{C}$		60		100
$t_{D2}$		Grouped OUT $n$ on or off to next group on or off, $T_A = +25^{\circ}\text{C}$		2		ns
$t_{ON\_ERR}$	Output on-time error <sup>(1)</sup> Output on or off latch data = all '1', 50-ns BLANK GND level pulse, $V_{CC} = 3.3\text{ V}$ , $T_A = +25^{\circ}\text{C}$		-45	45	ns	

- (1) Output on-time error ( $t_{ON\_ERR}$ ) is calculated by the formula:  $t_{ON\_ERR}$  (ns) =  $t_{OUT\_ON}$  – BLANK low level one-shot pulse width ( $t_{WL2}$ ).  $t_{OUT\_ON}$  indicates the actual on-time of the constant-current output.

## PIN CONFIGURATIONS

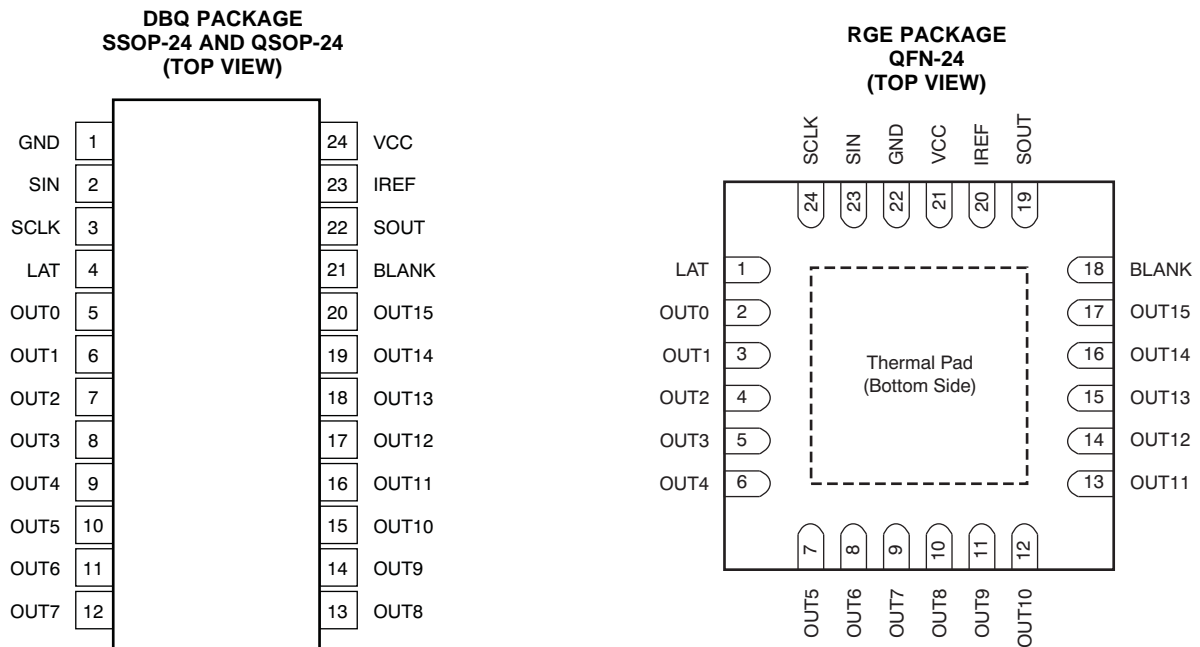

NOTE: Thermal pad is not connected to GND internally. The thermal pad must be connected to GND via the printed circuit board (PCB) pattern.

## PIN DESCRIPTIONS

NAME	PIN		I/O	DESCRIPTION
	NUMBER			
	DBQ	RGE		
BLANK	21	18	I	All outputs empty (blank); Schmitt buffer input. When BLANK is high, all constant-current outputs (OUT0 to OUT15) are forced off and all pre-charge FETs are turned on. When BLANK is low, all constant-current outputs are controlled by the data in the output on or off data latch and all pre-charge FETs are turned off. This pin is internally pulled up to $V_{CC}$ with a 500-k $\Omega$ (typ) resistor.
GND	1	22	—	Power ground
IREF	23	20	I/O	Constant-current value setting, the OUT0 to OUT15 sink constant-current outputs are set to the desired values by connecting an external resistor between IREF and GND.
LAT	4	1	I	Level-triggered latch; Schmitt buffer input. The data in the 16-bit shift register continue to transfer to the output on or off data latch while LAT is high. Therefore, if the data in the 16-bit shift register are changed when LAT is high, the data in the data latch are also changed. The data in the data latch are held when LAT is low. This pin is internally pulled down to GND with a 500-k $\Omega$ (typ) resistor.
OUT0	5	2	O	Constant-current output. Each output can be tied together with others to increase the constant-current. Different voltages can be applied to each output.
OUT1	6	3	O	Constant-current output
OUT2	7	4	O	Constant-current output
OUT3	8	5	O	Constant-current output
OUT4	9	6	O	Constant-current output
OUT5	10	7	O	Constant-current output
OUT6	11	8	O	Constant-current output
OUT7	12	9	O	Constant-current output
OUT8	13	10	O	Constant-current output
OUT9	14	11	O	Constant-current output
OUT10	15	12	O	Constant-current output
OUT11	16	13	O	Constant-current output
OUT12	17	14	O	Constant-current output
OUT13	18	15	O	Constant-current output
OUT14	19	16	O	Constant-current output
OUT15	20	17	O	Constant-current output
SCLK	3	24	I	Serial data shift clock; Schmitt buffer input. All data in the 16-bit shift register are shifted toward the MSB by a 1-bit SCLK synchronization.
SIN	2	23	I	Serial data input for driver on or off control; Schmitt buffer input. When SIN is high, the LSB is set to '1' for only one SCLK input rising edge. If two SCLK rising edges are input while SIN is high, then the 16-bit shift register LSB and LSB+1 are set to '1'. When SIN is low, the LSB is set to '0' at the SCLK input rising edge.
SOUT	22	19	O	Serial data output. This output is connected to the 16-bit shift register MSB. SOUT data changes at the SCLK rising edge.
VCC	24	21	—	Power-supply voltage

FUNCTIONAL BLOCK DIAGRAM

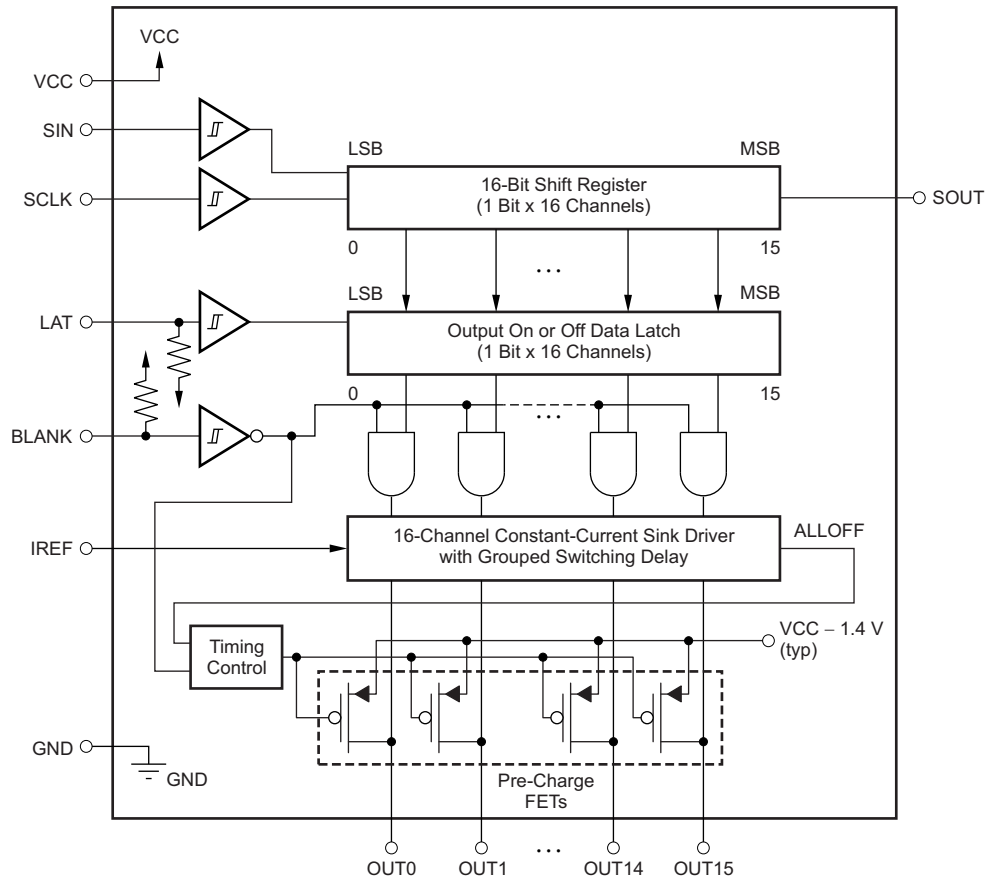

PARAMETER MEASUREMENT INFORMATION

PIN-EQUIVALENT INPUT AND OUTPUT SCHEMATIC DIAGRAMS

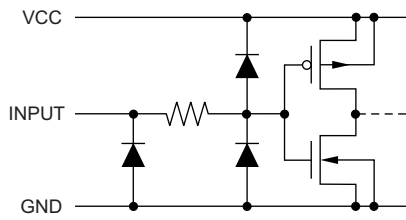

Figure 1. SIN and SCLK

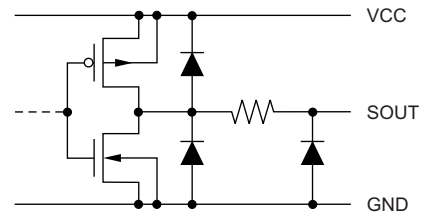

Figure 4. SOUT

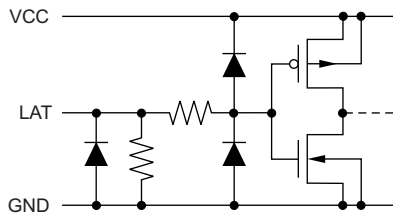
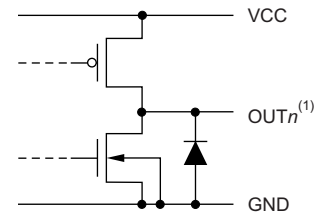

Figure 2. LAT



(1) n = 0 to 15.

Figure 5. OUT0 Through OUT15

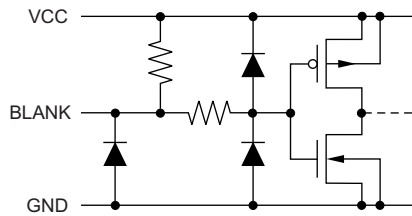

Figure 3. BLANK

TEST CIRCUITS

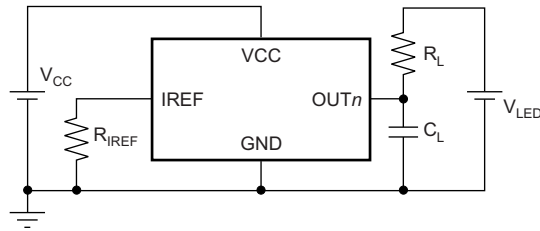

Figure 6.  $OUT_n$  Rise and Fall Time Test Circuit

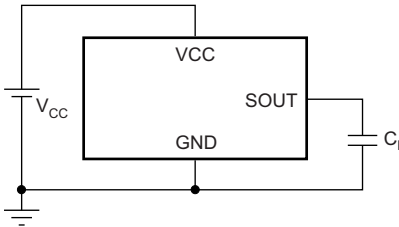

Figure 7. SOUT Rise and Fall Time Test Circuit

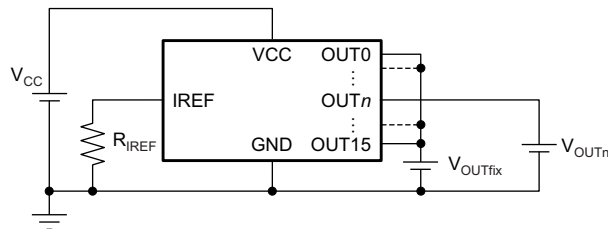
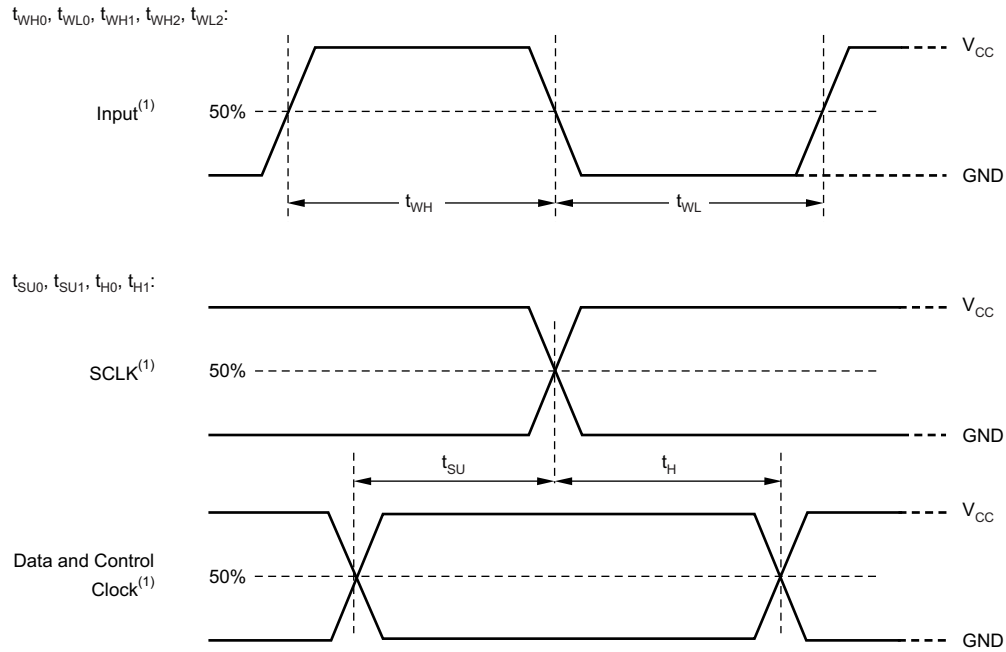

Figure 8.  $OUT_n$  Constant-Current Test Circuit

**TIMING DIAGRAMS**



(1) Input pulse rise and fall time is 1 ns to 3 ns.

**Figure 9. Input Timing Diagram**

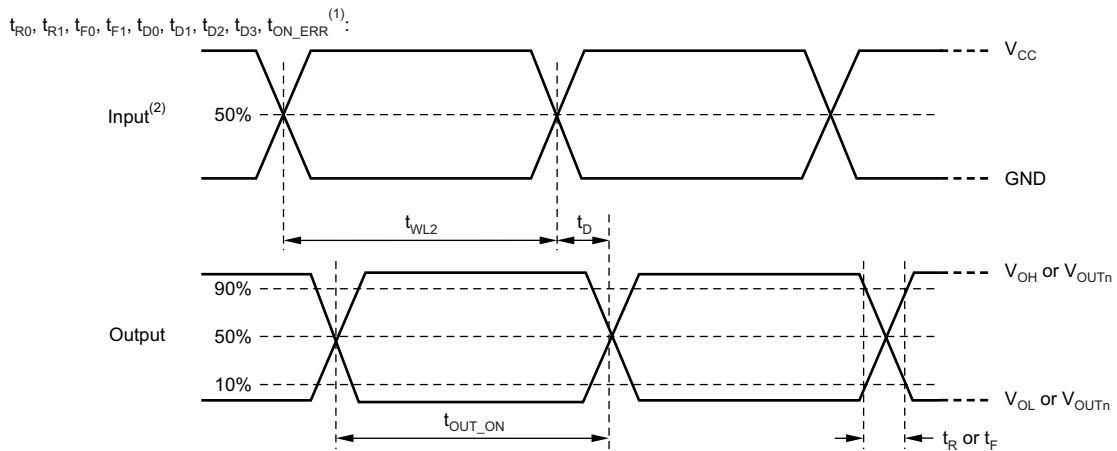

(1)  $t_{ON\_ERR}$  is calculated by  $t_{OUT\_ON} - t_{WL2}$ .

(2) Input pulse rise and fall time is 1 ns to 3 ns.

**Figure 10. Output Timing Diagram**

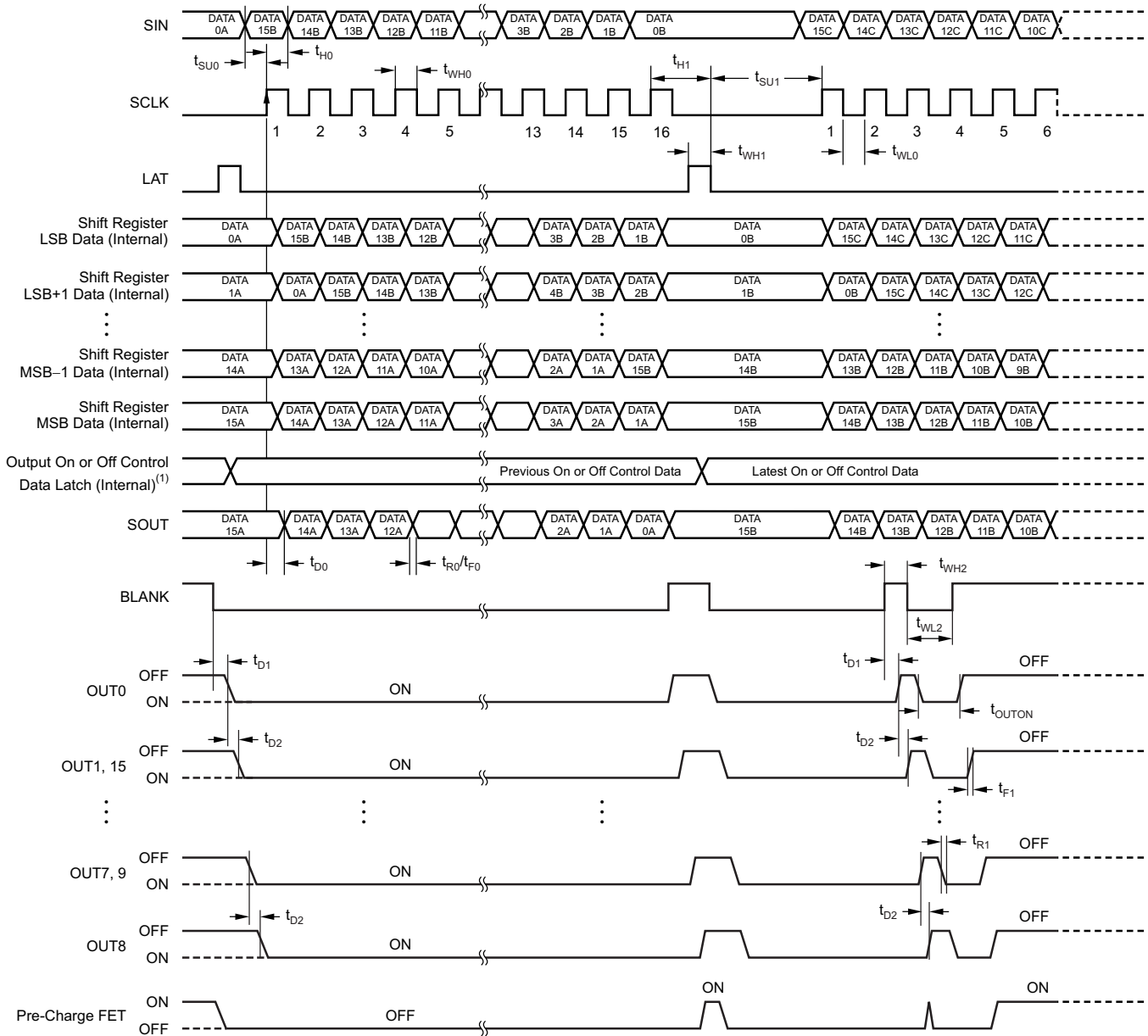

(1) Output on or off data = FFFFh.

(2)  $t_{ON\_ERR} = t_{OUTON} - t_{WL2}$ .

Figure 11. Data Write and Output On or Off Timing Diagram

### TYPICAL CHARACTERISTICS

At  $T_A = +25^\circ\text{C}$  and  $V_{CC} = 3.3\text{ V}$ , unless otherwise noted.

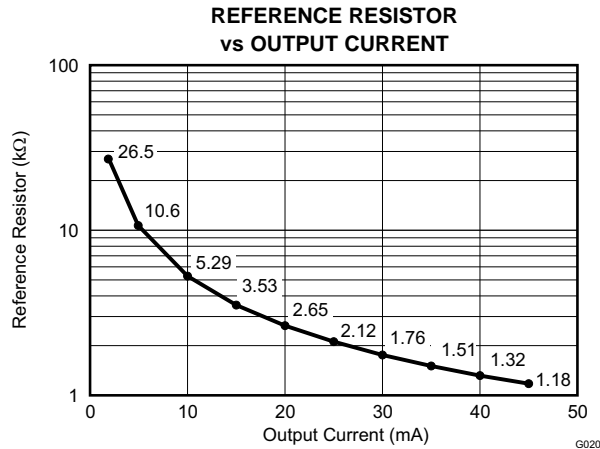

Figure 12.

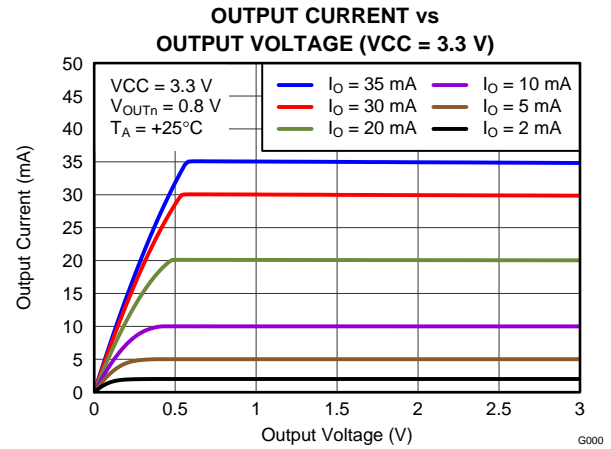

Figure 13.

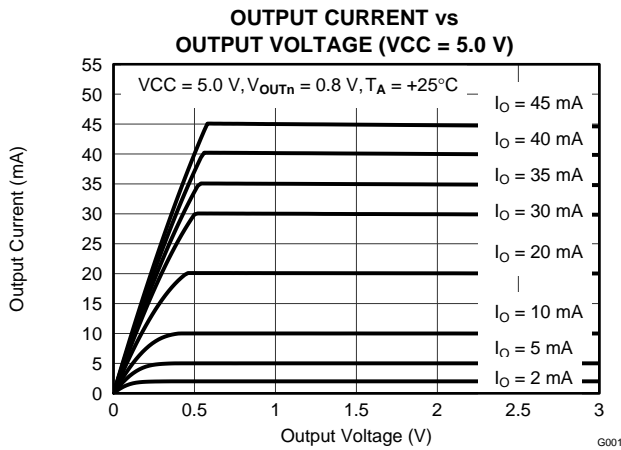

Figure 14.

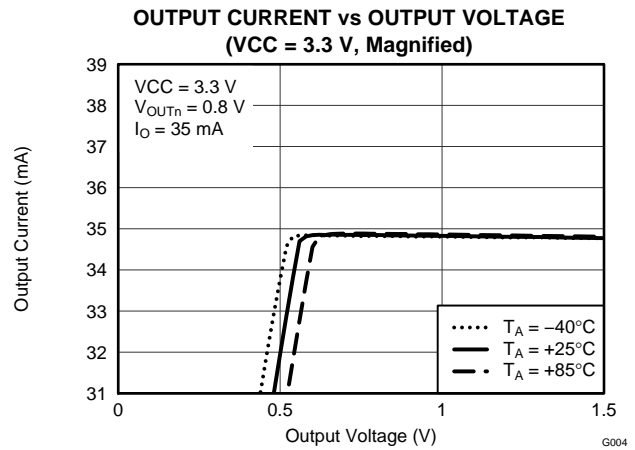

Figure 15.

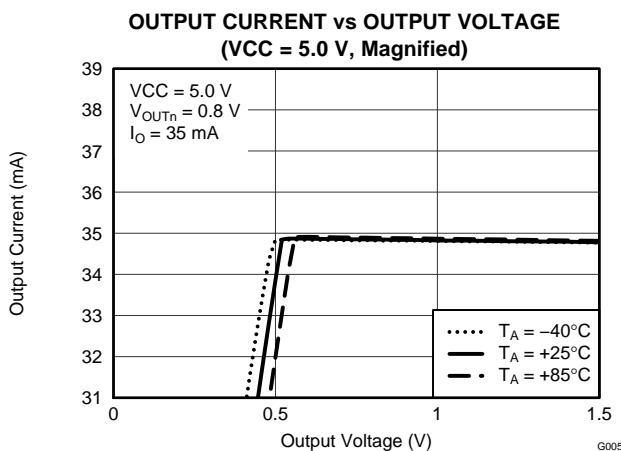

Figure 16.

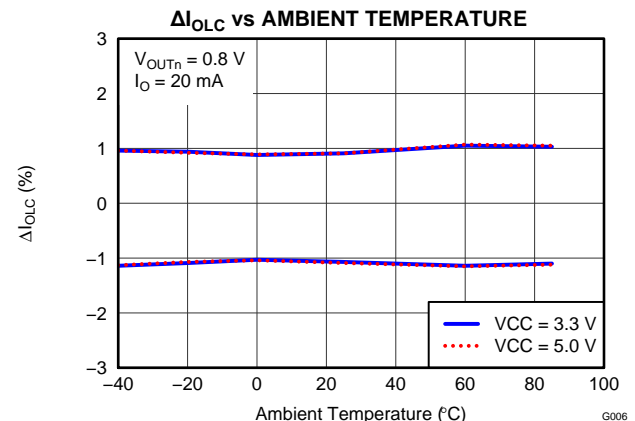
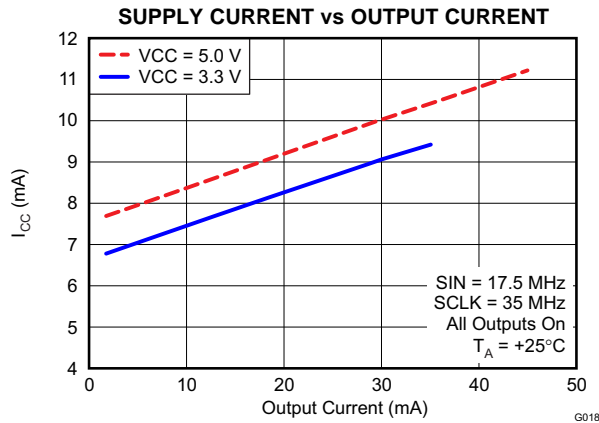

Figure 17.

**TYPICAL CHARACTERISTICS (continued)**

At  $T_A = +25^\circ\text{C}$  and  $V_{CC} = 3.3\text{ V}$ , unless otherwise noted.



**Figure 18.**

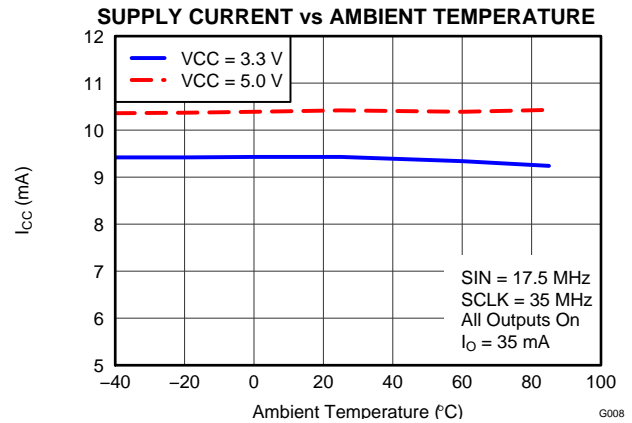

**Figure 19.**

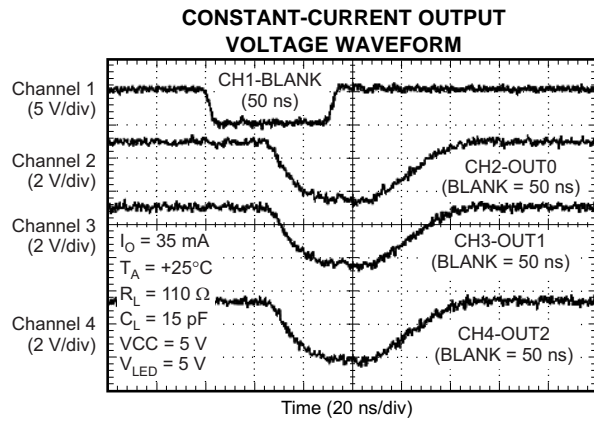

**Figure 20.**

## DETAILED DESCRIPTION

### CONSTANT SINK CURRENT VALUE SETTING

The constant-current values are determined by an external resistor ( $R_{IREF}$ ) placed between IREF and GND. The resistor ( $R_{IREF}$ ) value is calculated by [Equation 1](#).

$$R_{IREF} \text{ (k}\Omega\text{)} = \frac{V_{IREF} \text{ (V)}}{I_{OLC} \text{ (mA)}} \times 43.8$$

Where:

$$V_{IREF} = \text{the internal reference voltage on the IREF pin (typically 1.208 V)} \quad (1)$$

$I_{OLC}$  must be set in the range of 2 mA to 35 mA when  $V_{CC}$  is less than 3.6 V. Also, when  $V_{CC}$  is equal to 3.6 V or greater,  $I_{OLC}$  must be set in the range of 2 mA to 45 mA. The constant sink current characteristic for the external resistor value is illustrated in [Figure 12](#). [Table 1](#) describes the constant-current output versus external resistor value.

**Table 1. Constant-Current Output versus External Resistor Value**

$I_{OLC}$ (mA)	$R_{IREF}$ (k $\Omega$ , Typical)
45 ( $V_{CC} > 3.6$ V only)	1.18
40 ( $V_{CC} > 3.6$ V only)	1.32
35	1.51
30	1.76
25	2.12
20	2.65
15	3.53
10	5.29
5	10.6
2	26.5

### CONSTANT-CURRENT DRIVER ON OR OFF CONTROL

When BLANK is low, the corresponding output is turned on if the data in the on or off control data latch are '1' and remains off if the data are '0'. When BLANK is high, all outputs are forced off. This control is shown in [Table 2](#).

**Table 2. Output On or Off Control Data Truth Table**

OUTPUT ON OR OFF DATA	CONSTANT-CURRENT OUTPUT STATUS
0	Off
1	On

When the device is initially powered on, the data in the 16-bit shift register and output on or off data latch are not set to default values. Therefore, the output on or off data must be written to the data latch before turning the constant-current output on. **BLANK should be high when powered on because the constant-current may be turned on as a result of random data in the output on or off data latch.**

## REGISTER CONFIGURATION

The TLC59283 has a 16-bit shift register and an output on or off data latch. Both the shift register and data latch are 16 bits long and are used to turn the constant-current outputs on and off. Figure 21 shows the shift register and data latch configuration. The data at the SIN pin are shifted into the 16-bit shift register LSB at the rising edge of the SCLK pin; SOUT data change at the SCLK rising edge.

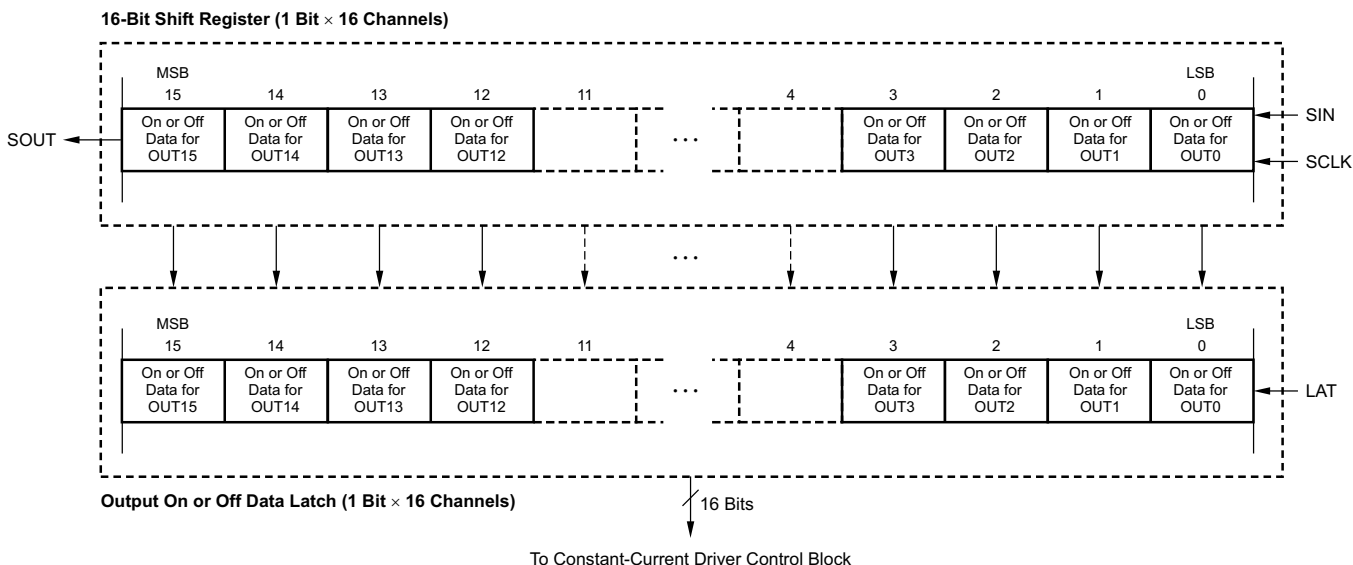

Figure 21. 16-Bit Shift Register and Output On or Off Data Latch Configuration

The output on or off data in the 16-bit shift register continue to transfer to the output on or off data latch while LAT is high. Therefore, if the data in the 16-bit shift register are changed when LAT is high, the data in the data latch are also changed. The data in the data latch are held when LAT is low. When the device initially powers on, the data in the output on or off shift register and latch are not set to default values; on or off control data must be written to the on or off control data latch before turning the constant-current output on. All constant-current outputs are forced off when BLANK is high. The OUT<sub>n</sub> on or off outputs are controlled by the data in the output on or off data latch. The writing data truth table and timing diagram are shown in Table 3 and Figure 22, respectively.

Table 3. Truth Table in Operation

SCLK	LAT	BLANK	SIN	OUT0...OUT7...OUT15	SOUT
↑	High	Low	D <sub>n</sub>	D <sub>n</sub> ...D <sub>n-7</sub> ...D <sub>n-15</sub>	D <sub>n-15</sub>
↑	Low	Low	D <sub>n+1</sub>	No change	D <sub>n-14</sub>
↑	High	Low	D <sub>n+2</sub>	D <sub>n+2</sub> ...D <sub>n-5</sub> ...D <sub>n-13</sub>	D <sub>n-13</sub>
↓	—	Low	D <sub>n+3</sub>	D <sub>n+2</sub> ...D <sub>n-5</sub> ...D <sub>n-13</sub>	D <sub>n-13</sub>
↓	—	High	D <sub>n+3</sub>	Off	D <sub>n-13</sub>

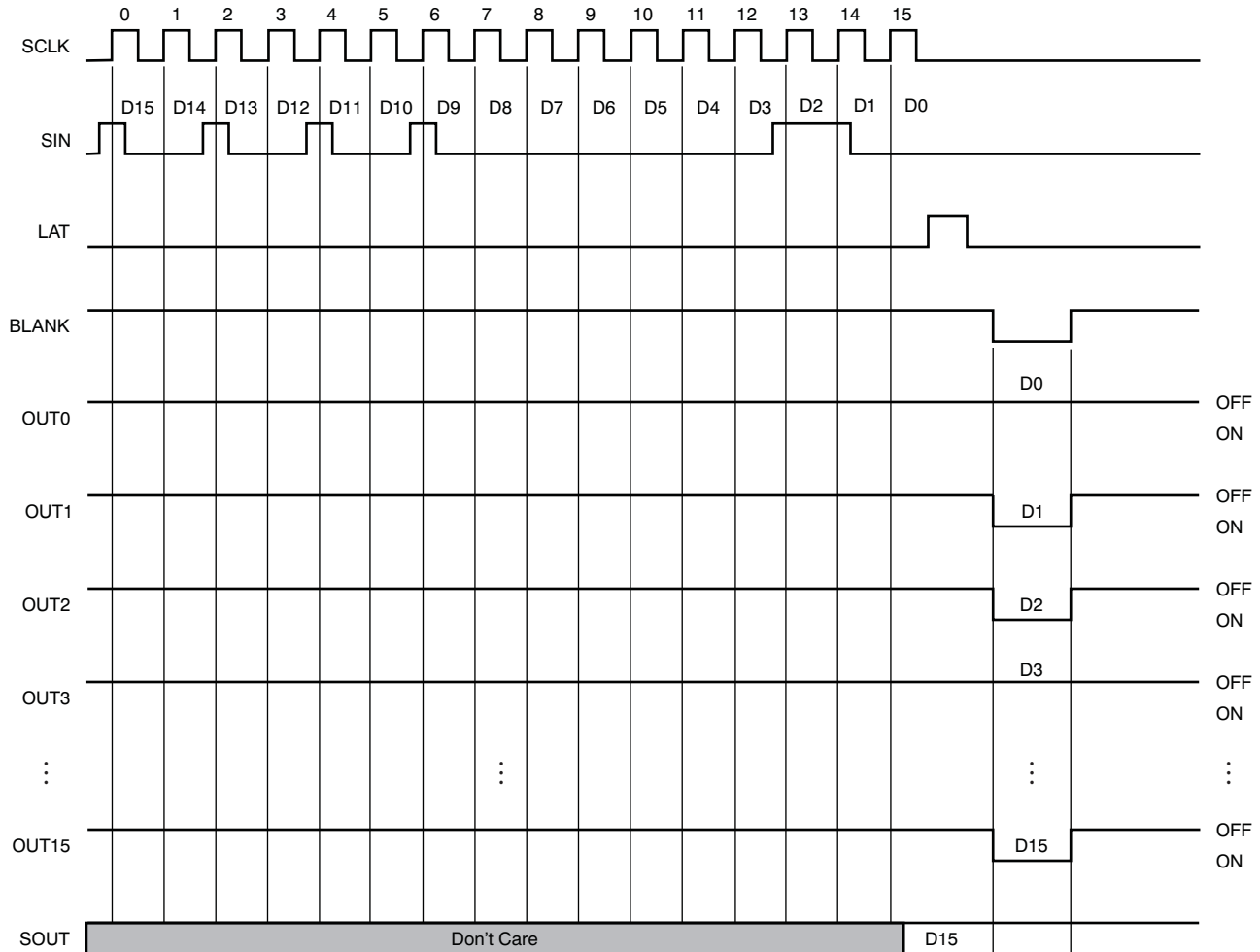

Figure 22. Operation Timing Diagram

### NOISE REDUCTION

Large surge currents may flow through the device and board if all 16 outputs turn on or off simultaneously. These large current surges can induce detrimental noise and electromagnetic interference (EMI) into other circuits. The TLC59283 independently turns on or off the outputs for each group with a 1-ns (typ) delay time; see Figure 11. The 16 outputs are grouped into nine groups of either one or two outputs: group 1 (OUT0), group 2 (OUT1 and OUT15), group 3 (OUT2 and OUT14), group 4 (OUT3 and OUT13), group 5 (OUT4 and OUT12), group 6 (OUT5 and OUT11), group 7 (OUT6 and OUT10), group 8 (OUT7 and OUT9), and group 9 (OUT9). Both turn-on and turn-off times are delayed when BLANK transitions from low to high or high to low. Also when output-on and -off data are changed at the LAT rising edge while BLANK is low, both turn-on and turn-off times are delayed. However, the state of each output is controlled by the data in the output on or off data latch and the BLANK level.

### Internal Pre-Charge FET

The internal pre-charge FET prevents ghosting of multiplexed LED modules. One cause of this phenomenon is the parasitic capacitance charging current of the constant-current outputs (OUT<sub>n</sub>) and PCB wiring connected to OUT<sub>n</sub> through the LED. One of the mechanisms is shown in Figure 23.

In Figure 23, the constant-current driver turns LED0-0 on at (1) and off at (2). After LED0-0 is turned off, the OUT0 voltage is pulled up to V<sub>CHG</sub> by LED0-0. This OUT0 node has some parasitic capacitance (such as the constant-current driver output capacitance and the board layout capacitance shown as C0-2). After LED0-0 turns off, SWPMOS0 is turned off, SWNMOS0 is turned on for COM0, and COM0 is pulled down to GND. Because there is a parasitic capacitance between COM0 and OUT0, the OUT0 voltage is also pulled down to GND. Afterwards, SWPMOS1 is turned on for the next common line (COM1). When SWPMOS1 turns on, the OUT0 voltage is pulled up from the ground voltage to V<sub>LED</sub> – V<sub>F</sub>. The charge current (I<sub>CHRG</sub>) flows to the parasitic capacitor (C0) through LED1-0, causing the LED to briefly turn on and creating a ghosting effect of LED1-0.

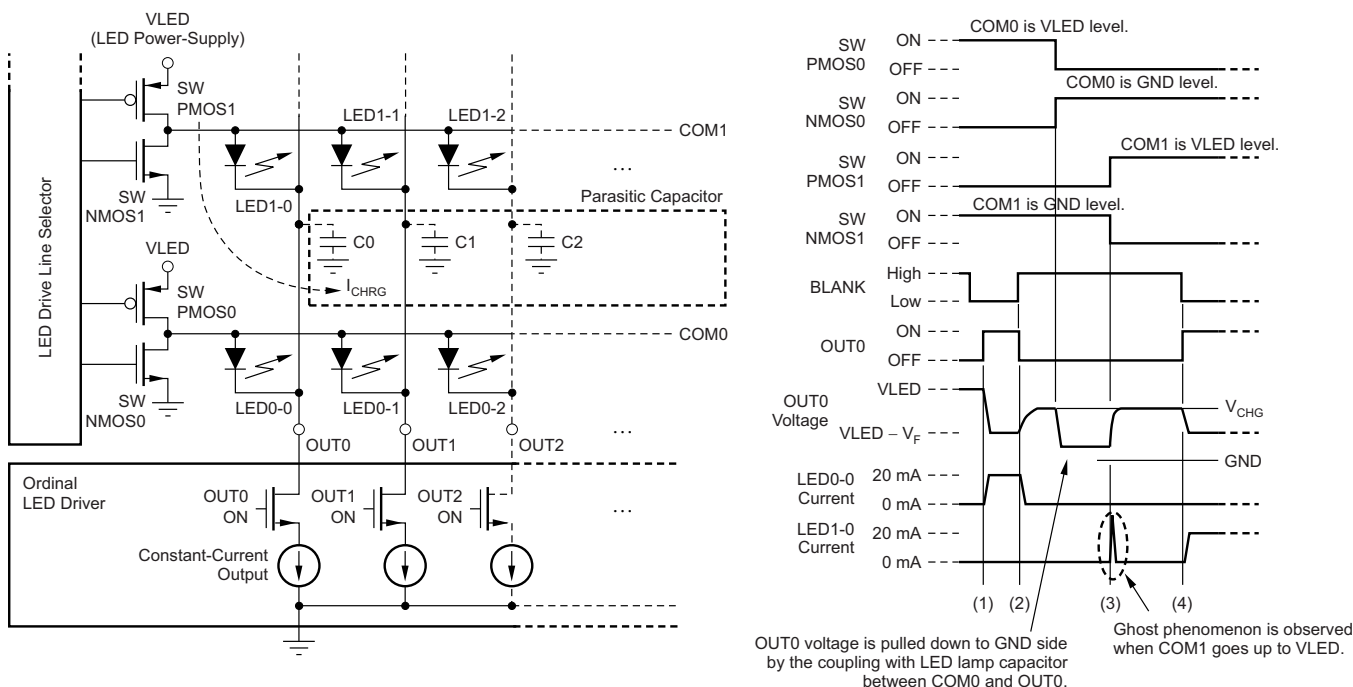

Figure 23. LED Ghost-Lighting Phenomenon Mechanism

The TLC59283 has an internal pre-charge FET to prevent ghosting, as shown in Figure 24. When a small delay after PWM control for a single common line completes, the FET pulls  $OUT_n$  up to  $V_{CC}$ . The charge current does not flow to  $C_0$  through LED1-0 when SWMOS1 is turned on and the ghosting is eliminated at (3). However, depending on the LED anode voltage, the number of LEDs in series, the LED forward voltage, and the TLC59283  $V_{CC}$  supply voltage, there may not be a great enough ghost-canceling effect.

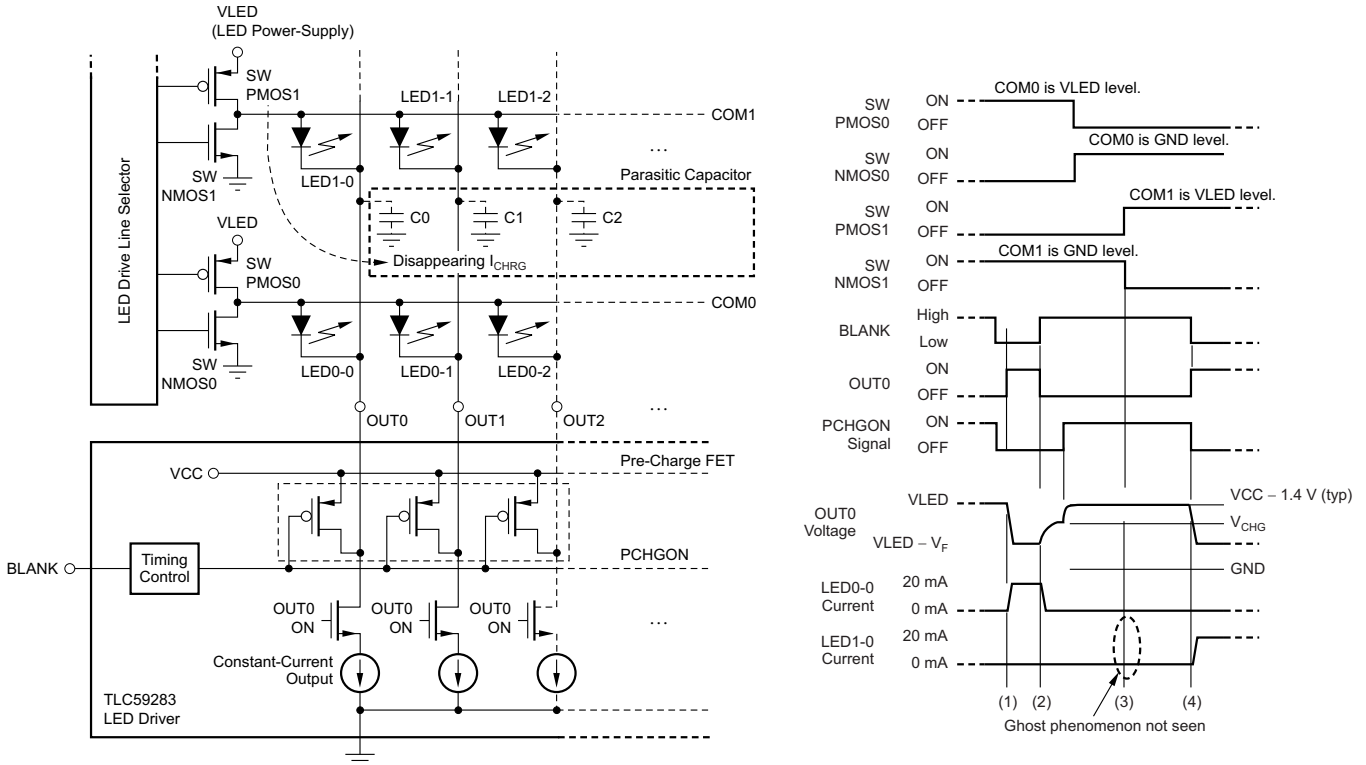

Figure 24. LED Ghost-Lighting Mechanism by Pre-Charge FET

## HISTORY TABLE

NOTE: Page numbers for previous revisions may differ from page numbers in the current version.

<b>Changes from Revision A (June 2012) to Revision B</b>	<b>Page</b>
• Changed HBM ESD rating maximum specification in the Absolute Maximum Ratings table .....	2
• Changed $I_{CC2}$ typical and maximum specifications in Electrical Characteristics table .....	4
• Changed $I_{CC3}$ typical specification in Electrical Characteristics table .....	4

**PACKAGING INFORMATION**

Orderable Device	Status (1)	Package Type	Package Drawing	Pins	Package Qty	Eco Plan (2)	Lead/Ball Finish	MSL Peak Temp (3)	Op Temp (°C)	Top-Side Markings (4)	Samples
TLC59283DBQ	ACTIVE	SSOP	DBQ	24	50	Green (RoHS & no Sb/Br)	CU NIPDAU	Level-2-260C-1 YEAR	-40 to 85	TLC59283	<a href="#">Samples</a>
TLC59283DBQR	ACTIVE	SSOP	DBQ	24	2500	Green (RoHS & no Sb/Br)	CU NIPDAU	Level-2-260C-1 YEAR	-40 to 85	TLC59283	<a href="#">Samples</a>
TLC59283RGER	ACTIVE	VQFN	RGE	24	3000	Green (RoHS & no Sb/Br)	CU NIPDAU	Level-2-260C-1 YEAR	-40 to 85	TLC 59283	<a href="#">Samples</a>
TLC59283RGET	ACTIVE	VQFN	RGE	24	250	Green (RoHS & no Sb/Br)	CU NIPDAU	Level-2-260C-1 YEAR	-40 to 85	TLC 59283	<a href="#">Samples</a>

(1) The marketing status values are defined as follows:

**ACTIVE:** Product device recommended for new designs.

**LIFEBUY:** TI has announced that the device will be discontinued, and a lifetime-buy period is in effect.

**NRND:** Not recommended for new designs. Device is in production to support existing customers, but TI does not recommend using this part in a new design.

**PREVIEW:** Device has been announced but is not in production. Samples may or may not be available.

**OBSELETE:** TI has discontinued the production of the device.

(2) Eco Plan - The planned eco-friendly classification: Pb-Free (RoHS), Pb-Free (RoHS Exempt), or Green (RoHS & no Sb/Br) - please check <http://www.ti.com/productcontent> for the latest availability information and additional product content details.

**TBD:** The Pb-Free/Green conversion plan has not been defined.

**Pb-Free (RoHS):** TI's terms "Lead-Free" or "Pb-Free" mean semiconductor products that are compatible with the current RoHS requirements for all 6 substances, including the requirement that lead not exceed 0.1% by weight in homogeneous materials. Where designed to be soldered at high temperatures, TI Pb-Free products are suitable for use in specified lead-free processes.

**Pb-Free (RoHS Exempt):** This component has a RoHS exemption for either 1) lead-based flip-chip solder bumps used between the die and package, or 2) lead-based die adhesive used between the die and leadframe. The component is otherwise considered Pb-Free (RoHS compatible) as defined above.

**Green (RoHS & no Sb/Br):** TI defines "Green" to mean Pb-Free (RoHS compatible), and free of Bromine (Br) and Antimony (Sb) based flame retardants (Br or Sb do not exceed 0.1% by weight in homogeneous material)

(3) MSL, Peak Temp. -- The Moisture Sensitivity Level rating according to the JEDEC industry standard classifications, and peak solder temperature.

(4) Multiple Top-Side Markings will be inside parentheses. Only one Top-Side Marking contained in parentheses and separated by a "~" will appear on a device. If a line is indented then it is a continuation of the previous line and the two combined represent the entire Top-Side Marking for that device.

**Important Information and Disclaimer:** The information provided on this page represents TI's knowledge and belief as of the date that it is provided. TI bases its knowledge and belief on information provided by third parties, and makes no representation or warranty as to the accuracy of such information. Efforts are underway to better integrate information from third parties. TI has taken and continues to take reasonable steps to provide representative and accurate information but may not have conducted destructive testing or chemical analysis on incoming materials and chemicals. TI and TI suppliers consider certain information to be proprietary, and thus CAS numbers and other limited information may not be available for release.

In no event shall TI's liability arising out of such information exceed the total purchase price of the TI part(s) at issue in this document sold by TI to Customer on an annual basis.



**TAPE AND REEL INFORMATION**

**QUADRANT ASSIGNMENTS FOR PIN 1 ORIENTATION IN TAPE**

\*All dimensions are nominal

Device	Package Type	Package Drawing	Pins	SPQ	Reel Diameter (mm)	Reel Width W1 (mm)	A0 (mm)	B0 (mm)	K0 (mm)	P1 (mm)	W (mm)	Pin1 Quadrant
TLC59283RGER	VQFN	RGE	24	3000	330.0	12.4	4.25	4.25	1.15	8.0	12.0	Q2
TLC59283RGET	VQFN	RGE	24	250	180.0	12.4	4.25	4.25	1.15	8.0	12.0	Q2

**TAPE AND REEL BOX DIMENSIONS**

\*All dimensions are nominal

Device	Package Type	Package Drawing	Pins	SPQ	Length (mm)	Width (mm)	Height (mm)
TLC59283RGER	VQFN	RGE	24	3000	367.0	367.0	35.0
TLC59283RGET	VQFN	RGE	24	250	210.0	185.0	35.0

DBQ (R-PDSO-G24)

PLASTIC SMALL-OUTLINE PACKAGE

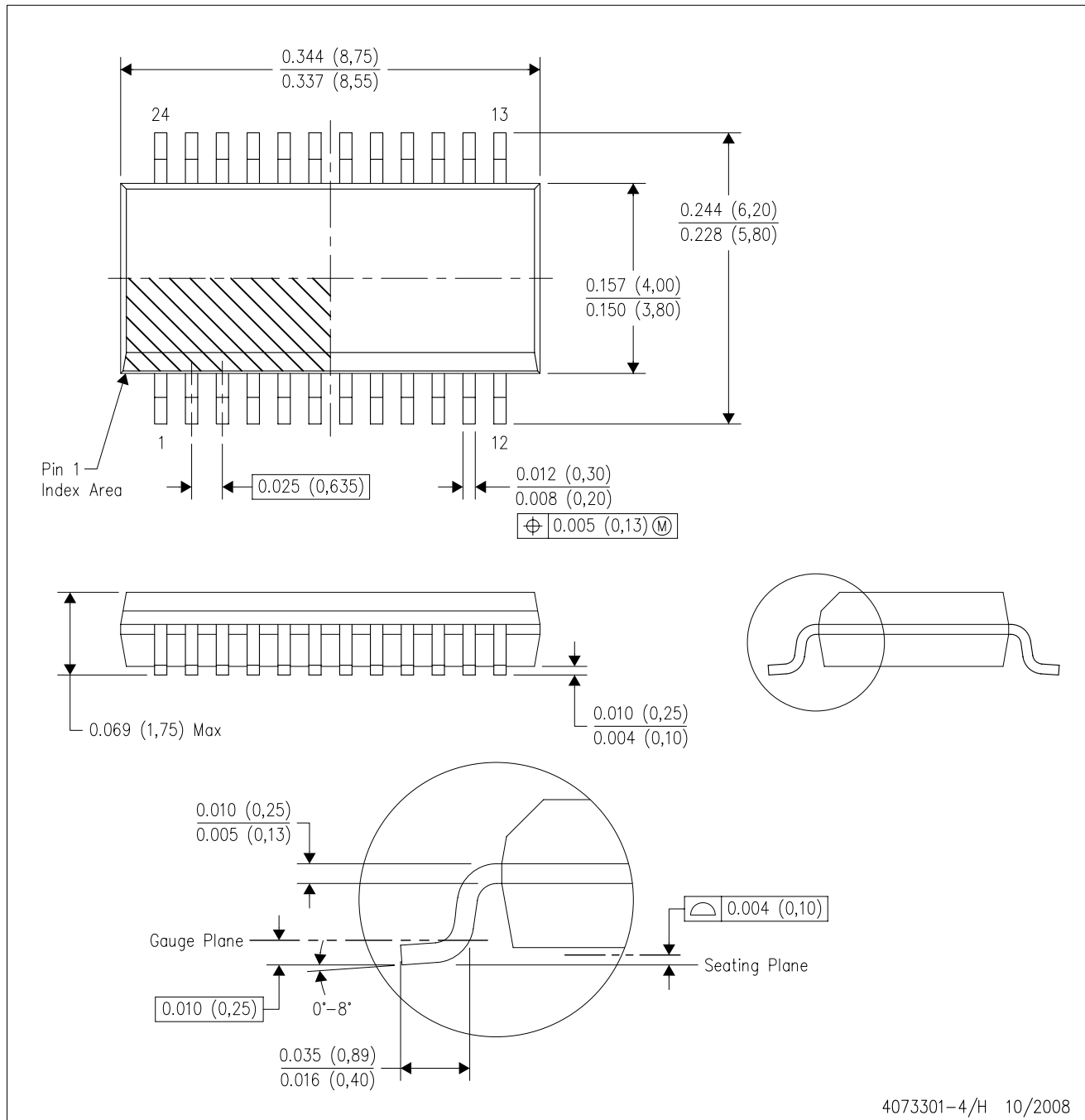

- NOTES:
- A. All linear dimensions are in inches (millimeters).
  - B. This drawing is subject to change without notice.
  - C. Body dimensions do not include mold flash or protrusion not to exceed 0.006 (0,15) per side.
  - D. Falls within JEDEC MO-137 variation AE.

DBQ (R-PDSO-G24)

PLASTIC SMALL OUTLINE PACKAGE

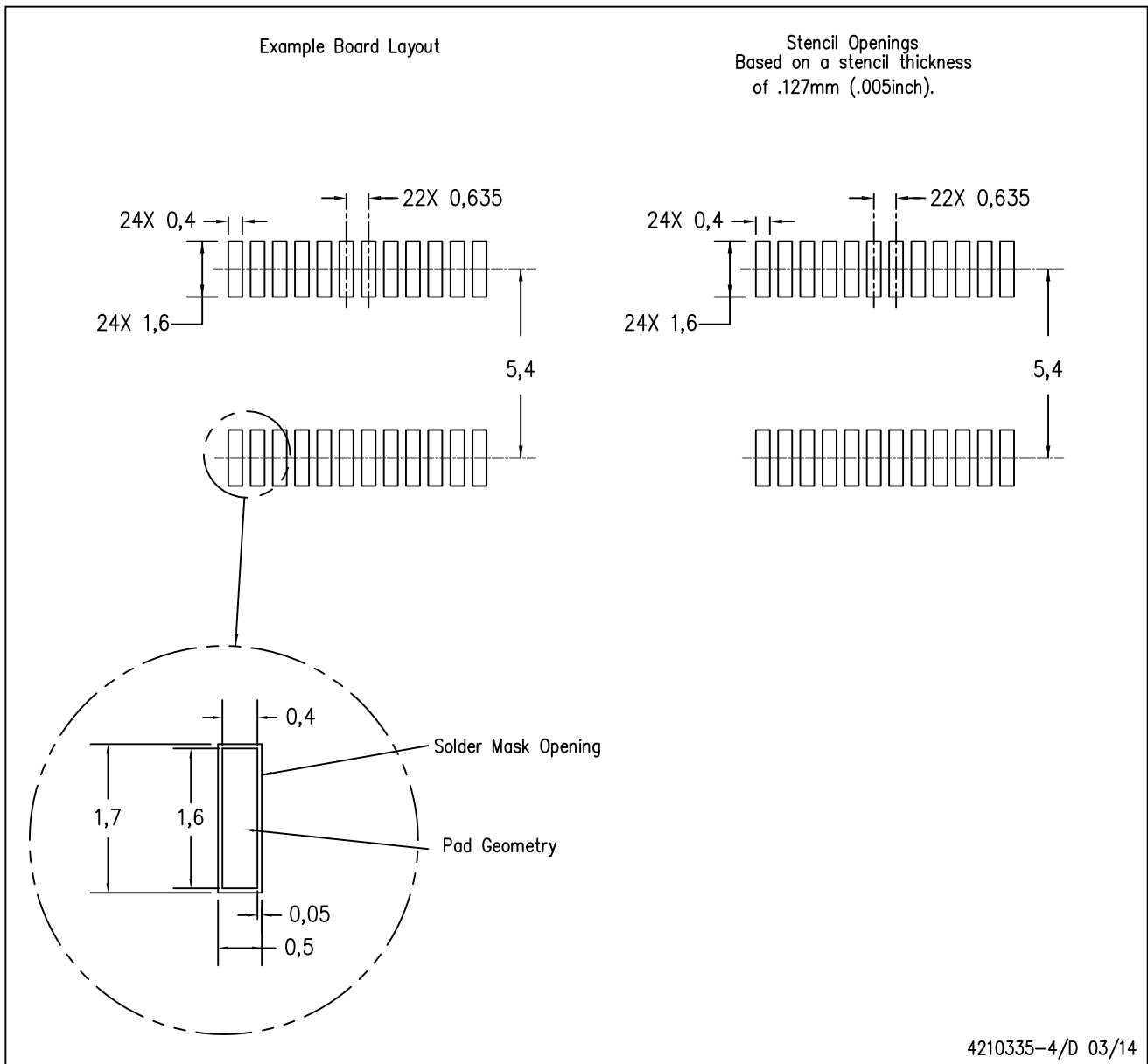

- NOTES:
- A. All linear dimensions are in millimeters.
  - B. This drawing is subject to change without notice.
  - C. Publication IPC-7351 is recommended for alternate designs.
  - D. Laser cutting apertures with trapezoidal walls and also rounding corners will offer better paste release. Customers should contact their board assembly site for stencil design recommendations. Example stencil design based on a 50% volumetric metal load solder paste. Refer to IPC-7525 for other stencil recommendations.

RGE (S-PVQFN-N24)

PLASTIC QUAD FLATPACK NO-LEAD

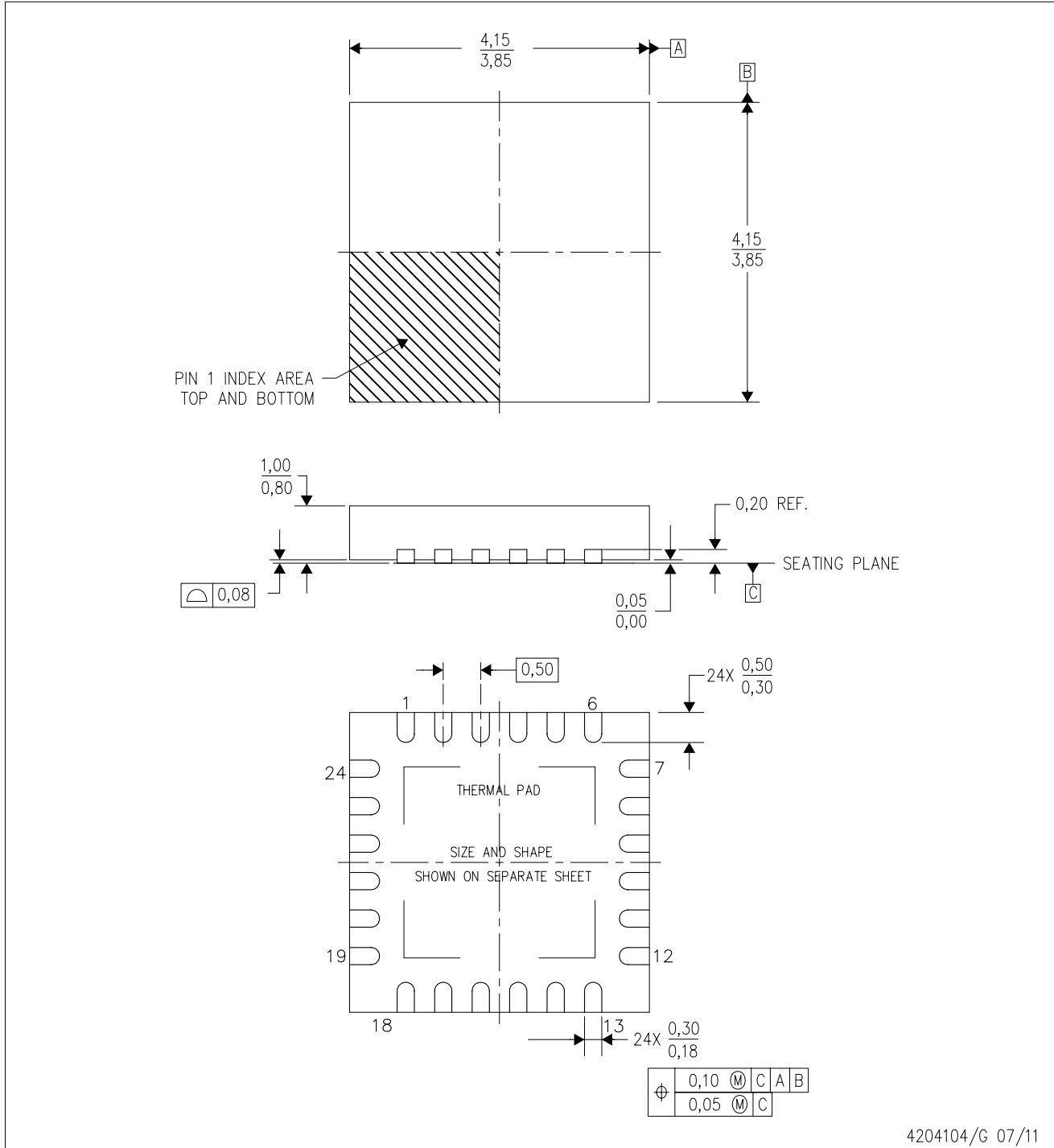

4204104/G 07/11

- NOTES:
- All linear dimensions are in millimeters. Dimensioning and tolerancing per ASME Y14.5M-1994.
  - This drawing is subject to change without notice.
  - Quad Flatpack, No-Leads (QFN) package configuration.
  - The package thermal pad must be soldered to the board for thermal and mechanical performance.
  - See the additional figure in the Product Data Sheet for details regarding the exposed thermal pad features and dimensions.
  - Falls within JEDEC MO-220.

# THERMAL PAD MECHANICAL DATA

RGE (S-PVQFN-N24)

PLASTIC QUAD FLATPACK NO-LEAD

## THERMAL INFORMATION

This package incorporates an exposed thermal pad that is designed to be attached directly to an external heatsink. The thermal pad must be soldered directly to the printed circuit board (PCB). After soldering, the PCB can be used as a heatsink. In addition, through the use of thermal vias, the thermal pad can be attached directly to the appropriate copper plane shown in the electrical schematic for the device, or alternatively, can be attached to a special heatsink structure designed into the PCB. This design optimizes the heat transfer from the integrated circuit (IC).

For information on the Quad Flatpack No-Lead (QFN) package and its advantages, refer to Application Report, QFN/SON PCB Attachment, Texas Instruments Literature No. SLUA271. This document is available at [www.ti.com](http://www.ti.com).

The exposed thermal pad dimensions for this package are shown in the following illustration.

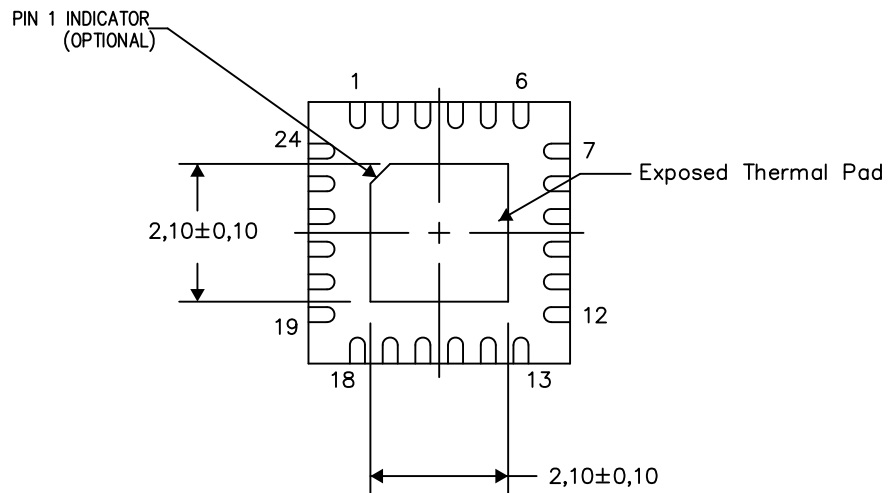

Bottom View

Exposed Thermal Pad Dimensions

4206344-6/AF 02/14

NOTES: A. All linear dimensions are in millimeters

RGE (S-PVQFN-N24)

PLASTIC QUAD FLATPACK NO-LEAD

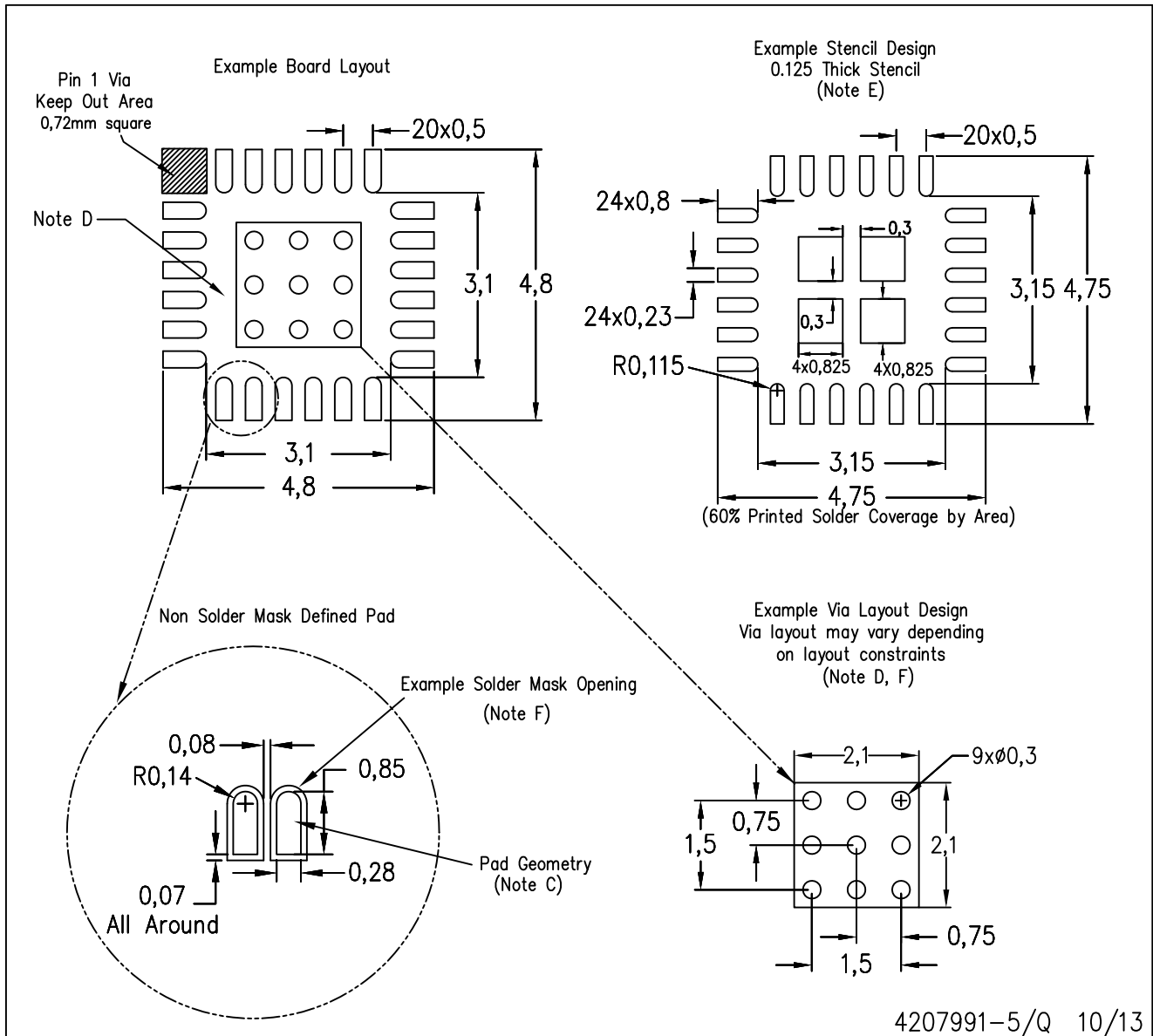

- NOTES:
- All linear dimensions are in millimeters.
  - This drawing is subject to change without notice.
  - Publication IPC-7351 is recommended for alternate designs.
  - This package is designed to be soldered to a thermal pad on the board. Refer to Application Note, Quad Flat-Pack Packages, Texas Instruments Literature No. SLUA271, and also the Product Data Sheets for specific thermal information, via requirements, and recommended board layout. These documents are available at [www.ti.com](http://www.ti.com) <<http://www.ti.com>>.
  - Laser cutting apertures with trapezoidal walls and also rounding corners will offer better paste release. Customers should contact their board assembly site for stencil design recommendations. Refer to IPC 7525 for stencil design considerations.
  - Customers should contact their board fabrication site for recommended solder mask tolerances and via tenting recommendations for vias placed in the thermal pad.

## IMPORTANT NOTICE

Texas Instruments Incorporated and its subsidiaries (TI) reserve the right to make corrections, enhancements, improvements and other changes to its semiconductor products and services per JESD46, latest issue, and to discontinue any product or service per JESD48, latest issue. Buyers should obtain the latest relevant information before placing orders and should verify that such information is current and complete. All semiconductor products (also referred to herein as "components") are sold subject to TI's terms and conditions of sale supplied at the time of order acknowledgment.

TI warrants performance of its components to the specifications applicable at the time of sale, in accordance with the warranty in TI's terms and conditions of sale of semiconductor products. Testing and other quality control techniques are used to the extent TI deems necessary to support this warranty. Except where mandated by applicable law, testing of all parameters of each component is not necessarily performed.

TI assumes no liability for applications assistance or the design of Buyers' products. Buyers are responsible for their products and applications using TI components. To minimize the risks associated with Buyers' products and applications, Buyers should provide adequate design and operating safeguards.

TI does not warrant or represent that any license, either express or implied, is granted under any patent right, copyright, mask work right, or other intellectual property right relating to any combination, machine, or process in which TI components or services are used. Information published by TI regarding third-party products or services does not constitute a license to use such products or services or a warranty or endorsement thereof. Use of such information may require a license from a third party under the patents or other intellectual property of the third party, or a license from TI under the patents or other intellectual property of TI.

Reproduction of significant portions of TI information in TI data books or data sheets is permissible only if reproduction is without alteration and is accompanied by all associated warranties, conditions, limitations, and notices. TI is not responsible or liable for such altered documentation. Information of third parties may be subject to additional restrictions.

Resale of TI components or services with statements different from or beyond the parameters stated by TI for that component or service voids all express and any implied warranties for the associated TI component or service and is an unfair and deceptive business practice. TI is not responsible or liable for any such statements.

Buyer acknowledges and agrees that it is solely responsible for compliance with all legal, regulatory and safety-related requirements concerning its products, and any use of TI components in its applications, notwithstanding any applications-related information or support that may be provided by TI. Buyer represents and agrees that it has all the necessary expertise to create and implement safeguards which anticipate dangerous consequences of failures, monitor failures and their consequences, lessen the likelihood of failures that might cause harm and take appropriate remedial actions. Buyer will fully indemnify TI and its representatives against any damages arising out of the use of any TI components in safety-critical applications.

In some cases, TI components may be promoted specifically to facilitate safety-related applications. With such components, TI's goal is to help enable customers to design and create their own end-product solutions that meet applicable functional safety standards and requirements. Nonetheless, such components are subject to these terms.

No TI components are authorized for use in FDA Class III (or similar life-critical medical equipment) unless authorized officers of the parties have executed a special agreement specifically governing such use.

Only those TI components which TI has specifically designated as military grade or "enhanced plastic" are designed and intended for use in military/aerospace applications or environments. Buyer acknowledges and agrees that any military or aerospace use of TI components which have **not** been so designated is solely at the Buyer's risk, and that Buyer is solely responsible for compliance with all legal and regulatory requirements in connection with such use.

TI has specifically designated certain components as meeting ISO/TS16949 requirements, mainly for automotive use. In any case of use of non-designated products, TI will not be responsible for any failure to meet ISO/TS16949.

### Products

Audio	<a href="http://www.ti.com/audio">www.ti.com/audio</a>
Amplifiers	<a href="http://amplifier.ti.com">amplifier.ti.com</a>
Data Converters	<a href="http://dataconverter.ti.com">dataconverter.ti.com</a>
DLP® Products	<a href="http://www.dlp.com">www.dlp.com</a>
DSP	<a href="http://dsp.ti.com">dsp.ti.com</a>
Clocks and Timers	<a href="http://www.ti.com/clocks">www.ti.com/clocks</a>
Interface	<a href="http://interface.ti.com">interface.ti.com</a>
Logic	<a href="http://logic.ti.com">logic.ti.com</a>
Power Mgmt	<a href="http://power.ti.com">power.ti.com</a>
Microcontrollers	<a href="http://microcontroller.ti.com">microcontroller.ti.com</a>
RFID	<a href="http://www.ti-rfid.com">www.ti-rfid.com</a>
OMAP Applications Processors	<a href="http://www.ti.com/omap">www.ti.com/omap</a>
Wireless Connectivity	<a href="http://www.ti.com/wirelessconnectivity">www.ti.com/wirelessconnectivity</a>

### Applications

Automotive and Transportation	<a href="http://www.ti.com/automotive">www.ti.com/automotive</a>
Communications and Telecom	<a href="http://www.ti.com/communications">www.ti.com/communications</a>
Computers and Peripherals	<a href="http://www.ti.com/computers">www.ti.com/computers</a>
Consumer Electronics	<a href="http://www.ti.com/consumer-apps">www.ti.com/consumer-apps</a>
Energy and Lighting	<a href="http://www.ti.com/energy">www.ti.com/energy</a>
Industrial	<a href="http://www.ti.com/industrial">www.ti.com/industrial</a>
Medical	<a href="http://www.ti.com/medical">www.ti.com/medical</a>
Security	<a href="http://www.ti.com/security">www.ti.com/security</a>
Space, Avionics and Defense	<a href="http://www.ti.com/space-avionics-defense">www.ti.com/space-avionics-defense</a>
Video and Imaging	<a href="http://www.ti.com/video">www.ti.com/video</a>

### TI E2E Community

[e2e.ti.com](http://e2e.ti.com)