

LOW-POWER 16-CHANNEL CONSTANT-CURRENT LED SINK DRIVER

 Check for Samples: [TLC59025](#)

FEATURES

- 16 Constant-Current Output Channels
- Matches Industry Standard IOUT to External Resistor Ratio
- Constant Output Current Invariant to Load Voltage Change
- Excellent Output Current Accuracy:
 - Between Channels: < $\pm 5\%$ (Max)
 - Between ICs: < $\pm 6\%$ (Max)
- Constant Output Current Range: 3 mA to 45 mA
- Output Current Adjusted By External Resistor
- Fast Response of Output Current, \overline{OE} (Min): 100 ns
- 30-MHz Clock Frequency
- Schmitt-Trigger Inputs
- 3.3-V to 5-V Supply Voltage
- Thermal Shutdown for Overtemperature Protection
- ESD Performance: 1-kV HBM

APPLICATIONS

- Gaming Machine / Entertainment
- General LED Applications
- LED Display Systems
- Signs LED Lighting
- White Goods

DESCRIPTION/ORDERING INFORMATION

The TLC59025 is designed for LED displays and LED lighting applications. The TLC59025 contains a 16-bit shift register and data latches, which convert serial input data into parallel output format. At the TLC59025 output stage, 16 regulated-current ports provide uniform and constant current for driving LEDs within a wide range of VF variations. Used in system design for LED display applications (e.g., LED panels), the TLC59025 provides great flexibility and device performance. Users can adjust the output current from 3 mA to 45 mA through an external resistor, R_{ext} , which gives flexibility in controlling the light intensity of LEDs. TLC59025 is designed for up to 17 V at the output port. The high clock frequency, 30 MHz, also satisfies the system requirements of high-volume data transmission.

The serial data is transferred into TLC59025 via SDI, shifted in the shift register, and transferred out via SDO. LE can latch the serial data in the shift register to the output latch. \overline{OE} enables the output drivers to sink current.

Table 1. ORDERING INFORMATION⁽¹⁾

T_A	PACKAGE ⁽²⁾		ORDERABLE PART NUMBER	TOP-SIDE MARKING
–40°C to 85°C	PW	Reel of 2000	TLC59025IPWR	PREVIEW
	W-SOIC – DW	Reel of 2000	TLC59025IDWR	PREVIEW
	SSOP – DBQ	Reel of 2500	TLC59025IDBQR	TLC59025

(1) For the most current package and ordering information, see the Package Option Addendum at the end of this document, or see the TI web site at www.ti.com.

(2) Package drawings, thermal data, and symbolization are available at www.ti.com/packaging.



Please be aware that an important notice concerning availability, standard warranty, and use in critical applications of Texas Instruments semiconductor products and disclaimers thereto appears at the end of this data sheet.

BLOCK DIAGRAM

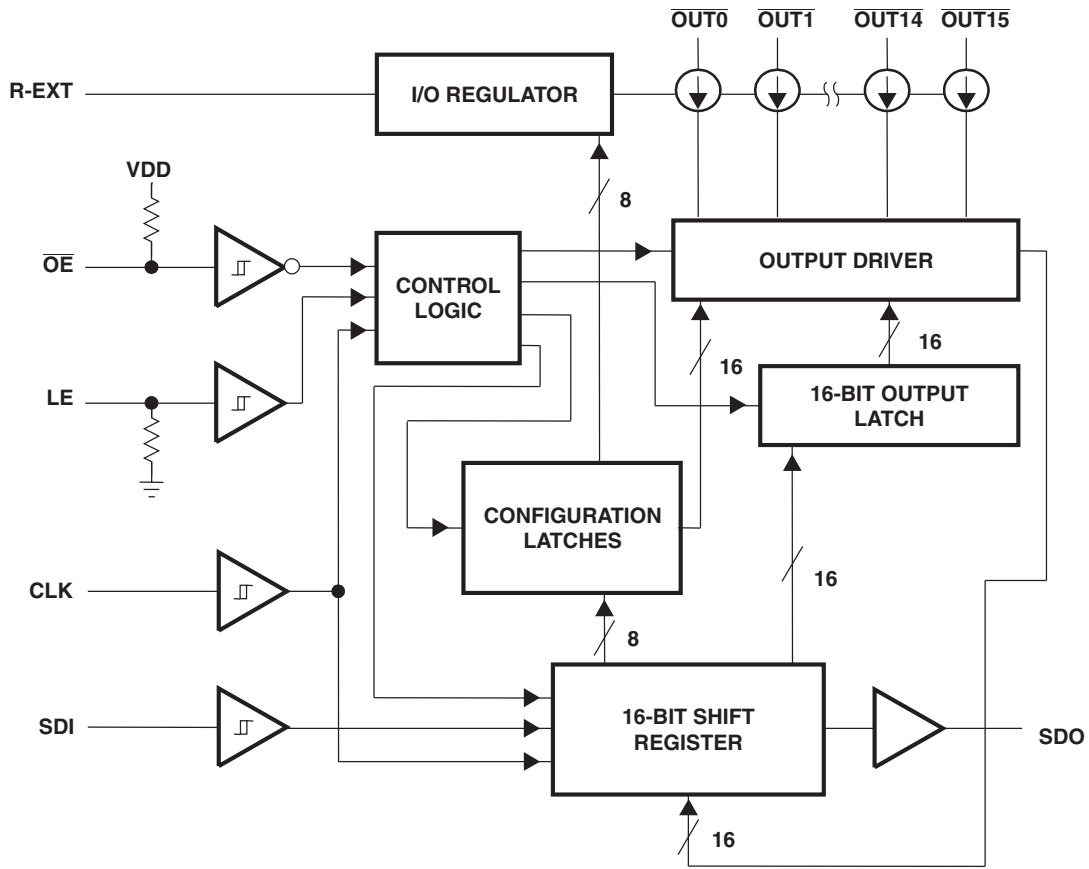

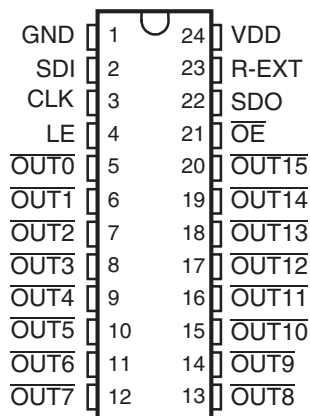
**DBQ, DW, OR PWP PACKAGE
(TOP VIEW)**

Terminal Descriptions

TERMINAL NAME	DESCRIPTION
CLK	Clock input for data shift on rising edge
GND	Ground for control logic and current sink
LE	Data strobe input Serial data is transferred to the respective latch when LE is high. The data is latched when LE goes low. LE has an internal pull-down resistor.
\overline{OE}	Output enable When \overline{OE} is active (low), the output drivers are enabled. When \overline{OE} is high, all output drivers are turned OFF (blanked). \overline{OE} has an internal pullup resistor.
$\overline{OUT0}$ – $\overline{OUT15}$	Constant-current outputs
R-EXT	Input used to connect an external resistor (R_{ext}) for setting output currents
SDI	Serial-data input to the Shift register
SDO	Serial-data output to the following SDI of next driver IC or to the microcontroller
VDD	Supply voltage

Timing Diagram

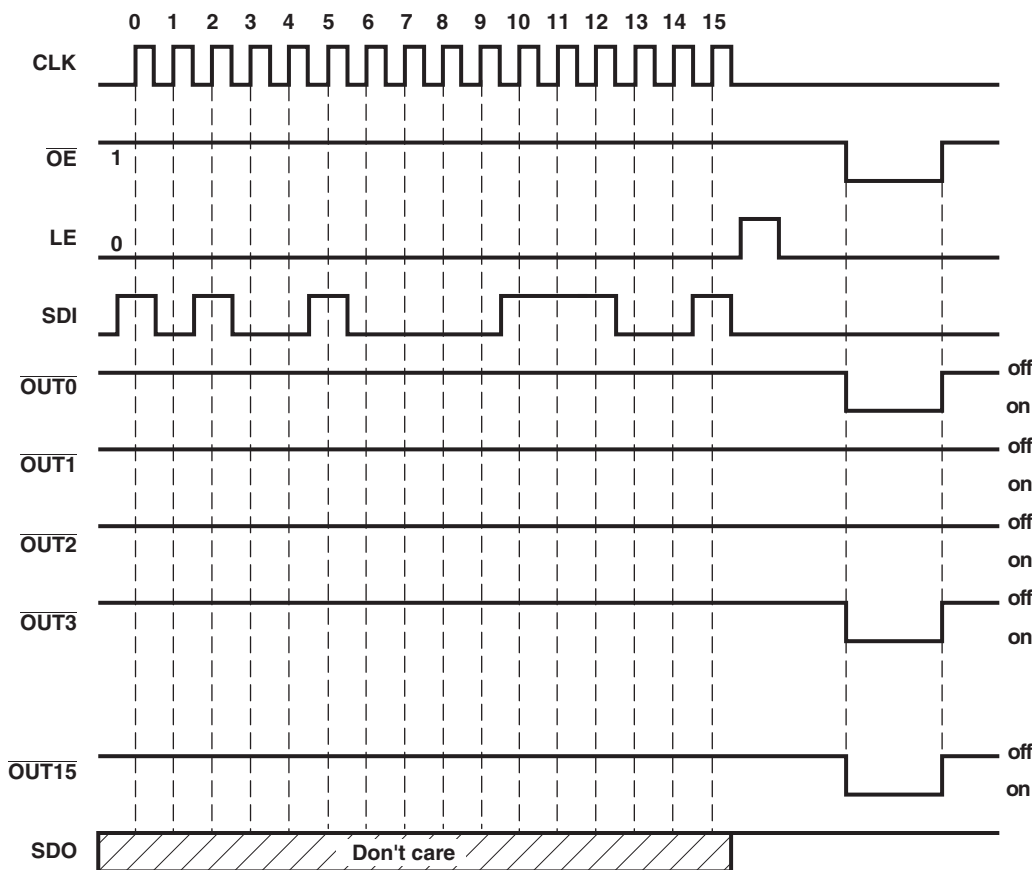

Figure 1. Timing Diagram

Table 2. Truth Table in Normal Operation

CLK	LE	\overline{OE}	SDI	$\overline{OUT0} \dots \overline{OUT15} \dots \overline{OUT15}$	SDO
↑	H	L	D_n	$D_n \dots D_{n-7} \dots D_{n-15}$	D_{n-15}
↑	L	L	D_{n+1}	No change	D_{n-14}
↑	H	L	D_{n+2}	$D_{n+2} \dots D_{n-5} \dots D_{n-13}$	D_{n-13}
↓	X	L	D_{n+3}	$D_{n+2} \dots D_{n-5} \dots D_{n-13}$	D_{n-13}
↓	X	H	D_{n+3}	off	D_{n-13}

Absolute Maximum Ratings

over operating free-air temperature range (unless otherwise noted)

		MIN	MAX	UNIT
V_{DD}	Supply voltage	0	7	V
V_I	Input voltage	-0.4	$V_{DD} + 0.4$	V
V_O	Output voltage	-0.5	20	V
I_{OUT}	Output current		45	mA
I_{GND}	GND terminal current		750	mA
T_A	Operating free-air temperature range	-40	125	°C
T_J	Operating virtual-junction temperature range	-40	150	°C
T_{stg}	Storage temperature range	-55	150	°C

Power Dissipation and Thermal Impedance

			MIN	MAX	UNIT
P_D	Power dissipation	Mounted on JEDEC 4-layer board (JESD 51-7), No airflow, $T_A = 25^\circ\text{C}$, $T_J = 125^\circ\text{C}$	DBQ package	1.6	W
			DW package	2.2	
			PW package	1.1	
θ_{JA}	Thermal impedance, junction to free air	Mounted on JEDEC 1-layer board (JESD 51-3), No airflow	DBQ package	99.8	°C/W
			DW package	80.5	
			PW package	118.8	
		Mounted on JEDEC 4-layer board (JESD 51-7), No airflow	DBQ package	61.0	
			DW package	45.5	
			PW package	87.9	

Recommended Operating Conditions

over operating free-air temperature range (unless otherwise noted)

		TEST CONDITIONS		MIN	MAX	UNIT
V _{DD}	Supply voltage			3	5.5	V
V _O	Output voltage	$\overline{\text{OUT0}}$ to $\overline{\text{OUT15}}$			17	V
I _O	Output current	DC test circuit	V _O ≥ 0.6 V	3		mA
			V _O ≥ 1 V		45	
I _{OH}	High-level output current	SDO		–1		mA
I _{OL}	Low-level output current	SDO		1		mA
V _{IH}	High-level input voltage	CLK, $\overline{\text{OE}}$, LE, and SDI		0.7 × V _{DD}	V _{DD}	V
V _{IL}	Low-level input voltage	CLK, $\overline{\text{OE}}$, LE, and SDI		GND	0.3 × V _{DD}	V
t _R	Rise time	CLK			500	ns
t _F	Fall time	CLK			500	ns

Recommended Timing

V_{DD} = 3 V to 5.5 V (unless otherwise noted)

		MIN	MAX	UNIT
t _{w(L)}	LE pulse duration	15		ns
t _{w(CLK)}	CLK pulse duration	15		ns
t _{w(OE)}	$\overline{\text{OE}}$ pulse duration	300		ns
t _{su(D)}	Setup time for SDI	3		ns
t _{h(D)}	Hold time for SDI	2		ns
t _{su(L)}	Setup time for LE	5		ns
t _{h(L)}	Hold time for LE	5		ns
f _{CLK}	Clock frequency	Cascade operation		30 MHz

Electrical Characteristics

 $V_{DD} = 3\text{ V}$, $T_J = -40^\circ\text{C}$ to 125°C (unless otherwise noted)

PARAMETER		TEST CONDITIONS	MIN	TYP	MAX	UNIT	
V_{DD}	Input voltage		3		5.5	V	
V_O	Output voltage				17	V	
I_O	Output current	$V_O \geq 0.6\text{ V}$	3			mA	
		$V_O \geq 1\text{ V}$			45		
I_{OH}	High-level output current, source		-1			mA	
I_{OL}	Low-level output current, sink		1				
V_{IH}	High-level input voltage		$0.7 \times V_{DD}$		V_{DD}	V	
V_{IL}	Low-level input voltage		GND		$0.3 \times V_{DD}$		
I_{leak}	Output leakage current	$V_{OH} = 17\text{ V}$	$T_J = 25^\circ\text{C}$		0.5	μA	
			$T_J = 125^\circ\text{C}$		2		
V_{OH}	High-level output voltage	SDO, $I_{OL} = -1\text{ mA}$	$V_{DD} - 0.4$			V	
V_{OL}	Low-level output voltage	SDO, $I_{OH} = 1\text{ mA}$			0.4	V	
$I_{O(1)}$	Output current 1	$V_{OUT} = 0.6\text{ V}$, $R_{ext} = 1440\ \Omega$		13		mA	
	Output current error, die-die	$I_{OL} = 13\text{ mA}$, $V_O = 0.6\text{ V}$, $R_{ext} = 1440\ \Omega$, $T_J = 25^\circ\text{C}$		± 3	± 6		%
	Output current error, channel-to-channel	$I_{OL} = 13\text{ mA}$, $V_O = 0.6\text{ V}$, $R_{ext} = 1440\ \Omega$, $T_J = 25^\circ\text{C}$		± 1.5	± 5		
$I_{O(2)}$	Output current 2	$V_O = 0.8\text{ V}$, $R_{ext} = 720\ \Omega$		26		mA	
	Output current error, die-die	$I_{OL} = 26\text{ mA}$, $V_O = 0.8\text{ V}$, $R_{ext} = 720\ \Omega$, $T_J = 25^\circ\text{C}$		± 3	± 6		%
	Output current error, channel-to-channel	$I_{OL} = 26\text{ mA}$, $V_O = 0.8\text{ V}$, $R_{ext} = 720\ \Omega$, $T_J = 25^\circ\text{C}$		± 1.5	± 5		
I_{OUT} vs V_{OUT}	Output current vs output voltage regulation	$V_O = 1\text{ V}$ to 3 V , $I_O = 13\text{ mA}$		± 0.1		%V	
		$V_{DD} = 3.0\text{ V}$ to 5.5 V , $I_O = 13\text{ mA}$ to 45 mA		± 1			
	Pullup resistance	\overline{OE}		500		k Ω	
	Pulldown resistance	LE		500		k Ω	
T_{sd}	Overtemperature shutdown ⁽¹⁾		150	175	200	$^\circ\text{C}$	
T_{hys}	Restart temperature hysteresis			15		$^\circ\text{C}$	
I_{DD}	Supply current	$R_{ext} = \text{Open}$		7	10	mA	
		$R_{ext} = 1440\ \Omega$		9	12		
		$R_{ext} = 720\ \Omega$		11	13		
C_{IN}	Input capacitance	$V_I = V_{DD}$ or GND, CLK, SDI, SDO, \overline{OE}			10	pF	

(1) Specified by design

Electrical Characteristics

$V_{DD} = 5.5\text{ V}$, $T_J = -40^\circ\text{C}$ to 125°C (unless otherwise noted)

PARAMETER		TEST CONDITIONS	MIN	TYP	MAX	UNIT	
V_{DD}	Input voltage		3		5.5	V	
V_O	Output voltage				17	V	
I_O	Output current	$V_O \geq 0.6\text{ V}$	3			mA	
		$V_O \geq 1\text{ V}$			45		
I_{OH}	High-level output current, source		-1			mA	
I_{OL}	Low-level output current, sink		1				
V_{IH}	High-level input voltage		$0.7 \times V_{DD}$		V_{DD}	V	
V_{IL}	Low-level input voltage		GND		$0.3 \times V_{DD}$		
I_{leak}	Output leakage current	$V_{OH} = 17\text{ V}$	$T_J = 25^\circ\text{C}$		0.5	μA	
			$T_J = 125^\circ\text{C}$		2		
V_{OH}	High-level output voltage	SDO, $I_{OL} = -1\text{ mA}$	$V_{DD} - 0.4$			V	
V_{OL}	Low-level output voltage	SDO, $I_{OH} = 1\text{ mA}$			0.4	V	
$I_{O(1)}$	Output current 1	$V_{OUT} = 0.6\text{ V}$, $R_{ext} = 1440\ \Omega$		13		mA	
	Output current error, die-die	$I_{OL} = 13\text{ mA}$, $V_O = 0.6\text{ V}$, $R_{ext} = 1440\ \Omega$, $T_J = 25^\circ\text{C}$		± 3	± 6		%
	Output current error, channel-to-channel	$I_{OL} = 13\text{ mA}$, $V_O = 0.6\text{ V}$, $R_{ext} = 1440\ \Omega$, $T_J = 25^\circ\text{C}$		± 1.5	± 5		
$I_{O(2)}$	Output current 2	$V_O = 0.8\text{ V}$, $R_{ext} = 720\ \Omega$		26		mA	
	Output current error, die-die	$I_{OL} = 26\text{ mA}$, $V_O = 0.8\text{ V}$, $R_{ext} = 720\ \Omega$, $T_J = 25^\circ\text{C}$		± 3	± 6		%
	Output current error, channel-to-channel	$I_{OL} = 26\text{ mA}$, $V_O = 0.8\text{ V}$, $R_{ext} = 720\ \Omega$, $T_J = 25^\circ\text{C}$		± 1.5	± 5		
I_{OUT} vs V_{OUT}	Output current vs output voltage regulation	$V_O = 1\text{ V}$ to 3 V , $I_O = 26\text{ mA}$		± 0.1		%V	
		$V_{DD} = 3.0\text{ V}$ to 5.5 V , $I_O = 13\text{ mA}$ to 45 mA		± 1			
	Pullup resistance	\overline{OE}		500		k Ω	
	Pulldown resistance	LE		500		k Ω	
T_{sd}	Overtemperature shutdown ⁽¹⁾		150	175	200	$^\circ\text{C}$	
T_{hys}	Restart temperature hysteresis			15		$^\circ\text{C}$	
I_{DD}	Supply current	$R_{ext} = \text{Open}$		9	11	mA	
		$R_{ext} = 1440\ \Omega$		12	14		
		$R_{ext} = 720\ \Omega$		14	16		
C_{IN}	Input capacitance	$V_I = V_{DD}$ or GND, CLK, SDI, SDO, \overline{OE}			10	pF	

(1) Specified by design

Switching Characteristics

 $V_{DD} = 3\text{ V}$, $T_J = -40^\circ\text{C}$ to 125°C (unless otherwise noted)

PARAMETER		TEST CONDITIONS	MIN	TYP	MAX	UNIT
t_{PLH1}	Low-to-high propagation delay time, CLK to $\overline{\text{OUTn}}$	$V_{IH} = V_{DD}$, $V_{IL} = \text{GND}$, $R_{\text{ext}} = 720\ \Omega$, $V_L = 4\ \text{V}$, $R_L = 88\ \Omega$, $C_L = 10\ \text{pF}$	30	45	60	ns
t_{PLH2}	Low-to-high propagation delay time, LE to $\overline{\text{OUTn}}$		30	45	60	ns
t_{PLH3}	Low-to-high propagation delay time, $\overline{\text{OE}}$ to $\overline{\text{OUTn}}$		30	45	60	ns
t_{PLH4}	Low-to-high propagation delay time, CLK to SDO			30	40	ns
t_{PHL1}	High-to-low propagation delay time, CLK to $\overline{\text{OUTn}}$		40	65	100	ns
t_{PHL2}	High-to-low propagation delay time, LE to $\overline{\text{OUTn}}$		40	65	100	ns
t_{PHL3}	High-to-low propagation delay time, $\overline{\text{OE}}$ to $\overline{\text{OUTn}}$		40	65	100	ns
t_{PHL4}	High-to-low propagation delay time, CLK to SDO			30	40	ns
$t_{w(\text{CLK})}$	Pulse duration, CLK		15			ns
$t_{w(\text{L})}$	Pulse duration LE		15			ns
$t_{w(\text{OE})}$	Pulse duration, $\overline{\text{OE}}$		300			ns
$t_{h(\text{D})}$	Hold time, SDI		2			ns
$t_{\text{su}(\text{D})}$	Setup time, SDI		3			ns
$t_{h(\text{L})}$	Hold time, LE		5			ns
$t_{\text{su}(\text{L})}$	Setup time, LE		5			ns
t_r	Rise time, CLK ⁽¹⁾				500	ns
t_f	Fall time, CLK ⁽¹⁾				500	ns
t_{or}	Rise time, outputs (off)		35	50	70	ns
t_{of}	Rise time, outputs (on)		15	50	120	ns
f_{CLK}	Clock frequency		Cascade operation			30

(1) If the devices are connected in cascade and t_r or t_f is large, it may be critical to achieve the timing required for data transfer between two cascaded devices.

Switching Characteristics

$V_{DD} = 5.5\text{ V}$, $T_J = -40^\circ\text{C}$ to 125°C (unless otherwise noted)

PARAMETER		TEST CONDITIONS	MIN	TYP	MAX	UNIT
t_{PLH1}	Low-to-high propagation delay time, CLK to $\overline{\text{OUTn}}$	$V_{IH} = V_{DD}$, $V_{IL} = \text{GND}$, $R_{\text{ext}} = 720\ \Omega$, $V_L = 4\ \text{V}$, $R_L = 88\ \Omega$, $C_L = 10\ \text{pF}$	20	35	55	ns
t_{PLH2}	Low-to-high propagation delay time, LE to $\overline{\text{OUTn}}$		20	35	55	ns
t_{PLH3}	Low-to-high propagation delay time, $\overline{\text{OE}}$ to $\overline{\text{OUTn}}$		20	35	55	ns
t_{PLH4}	Low-to-high propagation delay time, CLK to SDO			20	30	ns
t_{PHL1}	High-to-low propagation delay time, CLK to $\overline{\text{OUTn}}$		15	28	42	ns
t_{PHL2}	High-to-low propagation delay time, LE to $\overline{\text{OUTn}}$		15	28	42	ns
t_{PHL3}	High-to-low propagation delay time, $\overline{\text{OE}}$ to $\overline{\text{OUTn}}$		15	28	42	ns
t_{PHL4}	High-to-low propagation delay time, CLK to SDO			20	30	ns
$t_{w(\text{CLK})}$	Pulse duration, CLK		10			ns
$t_{w(\text{L})}$	Pulse duration LE		10			ns
$t_{w(\text{OE})}$	Pulse duration, $\overline{\text{OE}}$		200			ns
$t_{h(\text{D})}$	Hold time, SDI		2			ns
$t_{\text{su}(\text{D})}$	Setup time, SDI		3			ns
$t_{h(\text{L})}$	Hold time, LE		5			ns
$t_{\text{su}(\text{L})}$	Setup time, LE		5			ns
t_r	Rise time, CLK ⁽¹⁾				500	ns
t_f	Fall time, CLK ⁽¹⁾				500	ns
t_{or}	Rise time, outputs (off)		25	45	65	ns
t_{of}	Rise time, outputs (on)		7	12	20	ns
f_{CLK}	Clock frequency		Cascade operation			30

- (1) If the devices are connected in cascade and t_r or t_f is large, it may be critical to achieve the timing required for data transfer between two cascaded devices.

PARAMETER MEASUREMENT INFORMATION

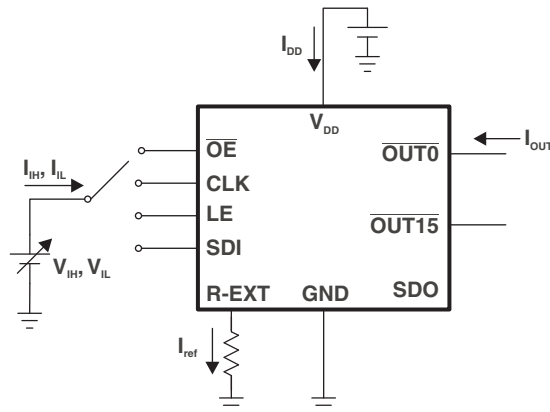

Figure 2. Test Circuit for Electrical Characteristics

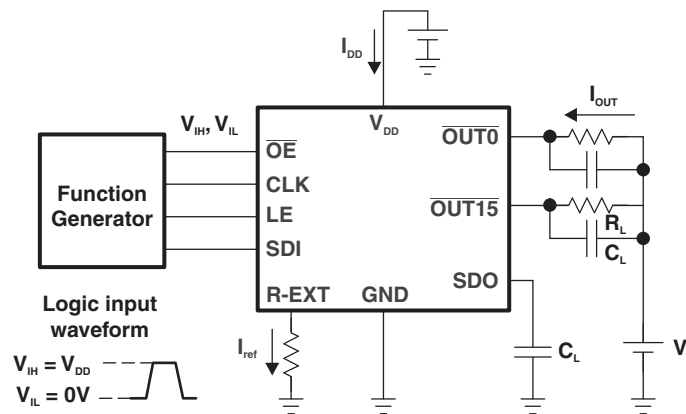

Figure 3. Test Circuit for Switching Characteristics

PARAMETER MEASUREMENT INFORMATION (continued)

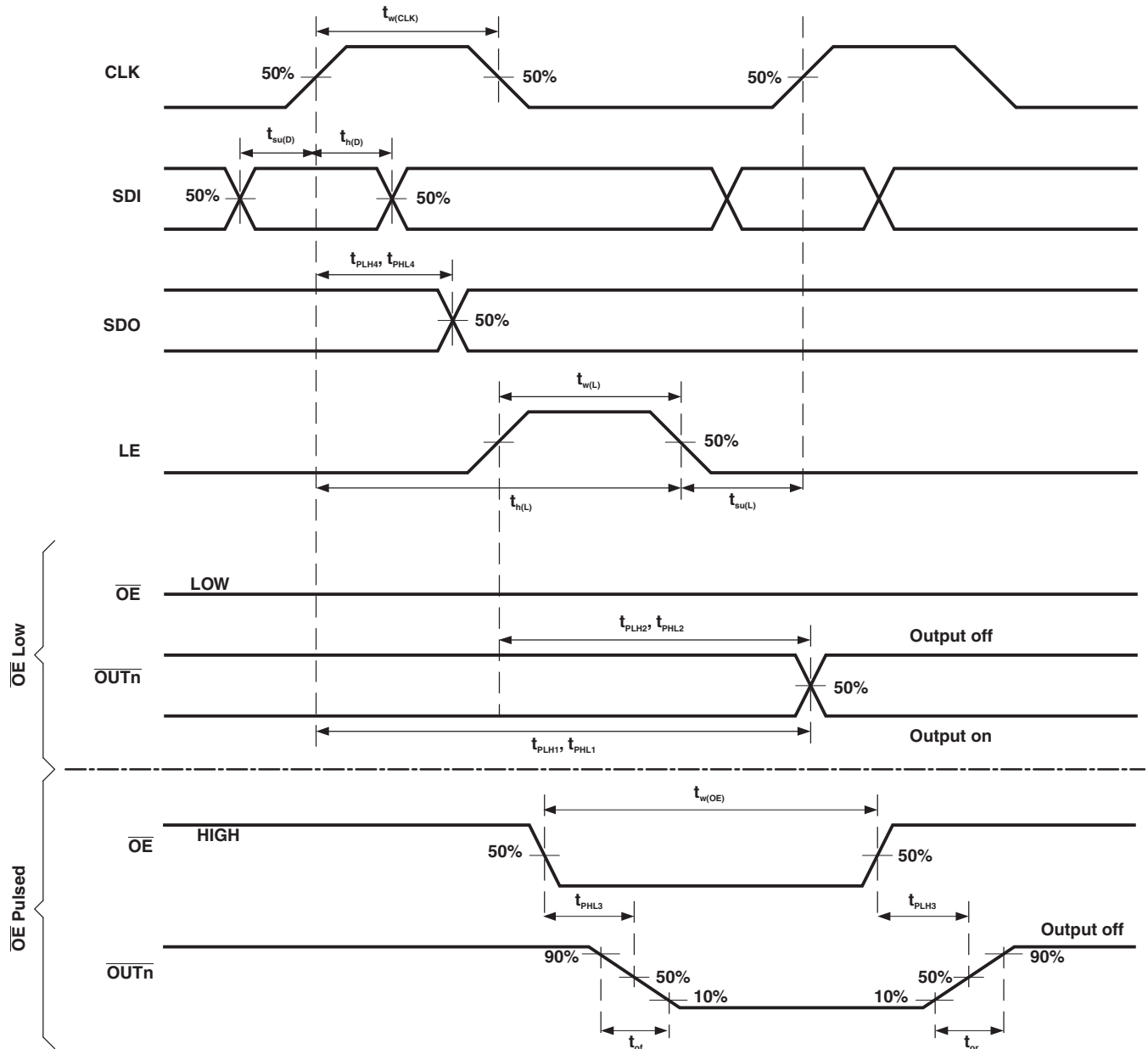

Figure 4. Normal Mode Timing Waveforms

APPLICATION INFORMATION

Operating Principles

Constant Current

In LED display applications, TLC59025 provides nearly no current variations from channel to channel and from IC to IC. While $I_{OUT} \leq 45$ mA, the maximum current skew between channels is less than $\pm 5\%$ and between ICs is less than $\pm 6\%$.

Adjusting Output Current

TLC59025 sets I_{OUT} based on the external resistor R_{ext} . Users can follow the below formulas to calculate the target output current $I_{OUT,target}$ in the saturation region:

$I_{OUT,target} = (1.21 \text{ V} / R_{ext}) \times 15.5$, where R_{ext} is the external resistance connected between R-EXT and GND.

Therefore, the default current is approximately 26 mA at 720 Ω and 13 mA at 1440 Ω . The default relationship after power on between $I_{OUT,target}$ and R_{ext} is shown in [Figure 5](#).

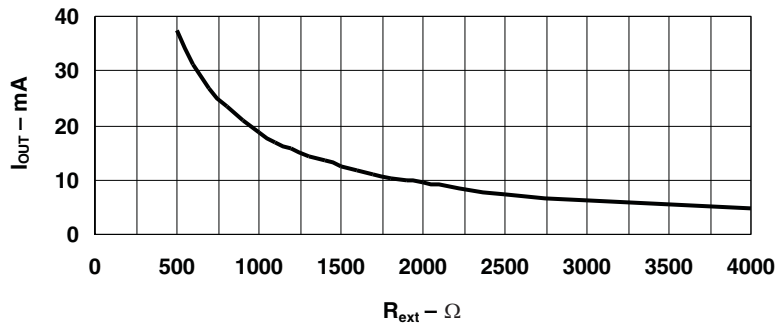

Figure 5. Default Relationship Curve Between $I_{OUT,target}$ and R_{ext} After Power Up

Propagation Delay Times

$V_{DD} = 5\text{ V}$
 $V_L = 4\text{ V}$
 $R_{ext} = 840\ \Omega$
 $R_L = 88\ \Omega$
 $C_L = 10\text{ pF}$

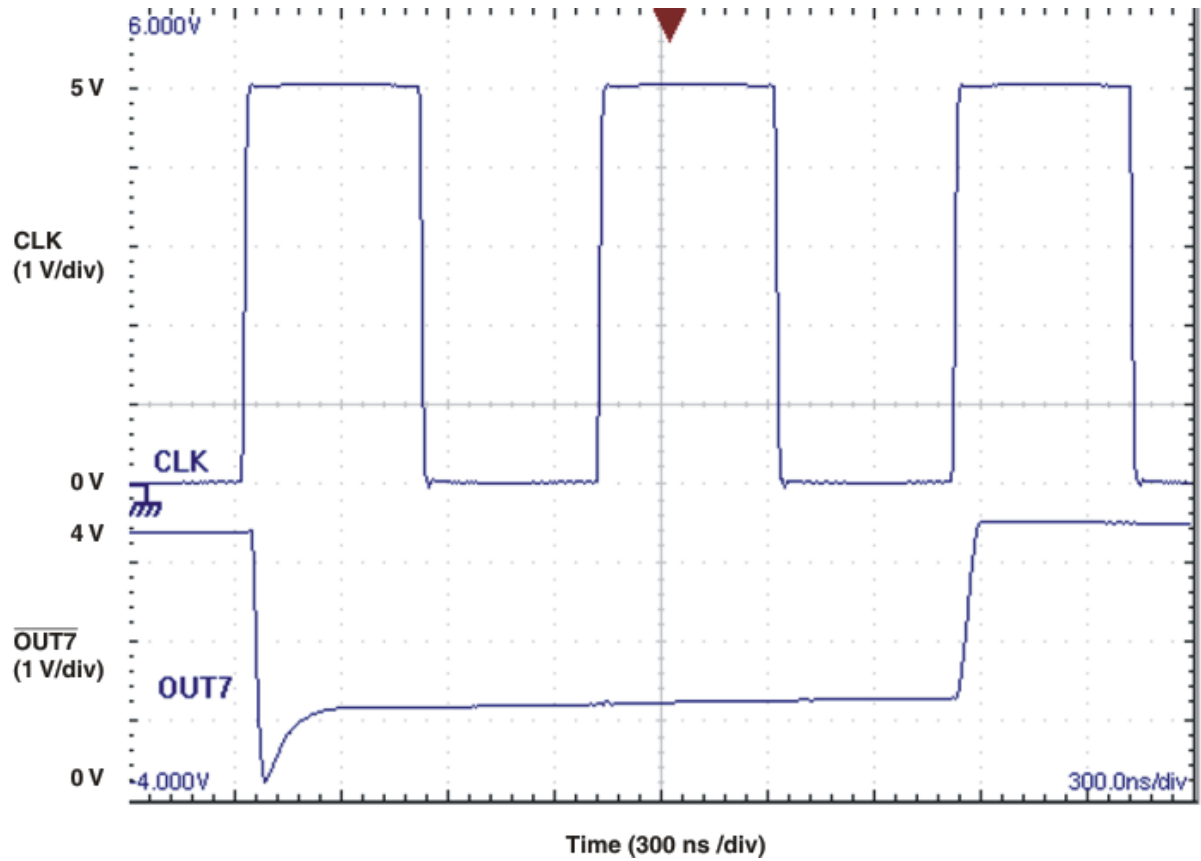

Figure 6. CLK to $\overline{\text{OUT7}}$

$V_{DD} = 5\text{ V}$
 $V_L = 4\text{ V}$
 $R_{ext} = 840\ \Omega$
 $R_L = 88\ \Omega$
 $C_L = 10\text{ pF}$

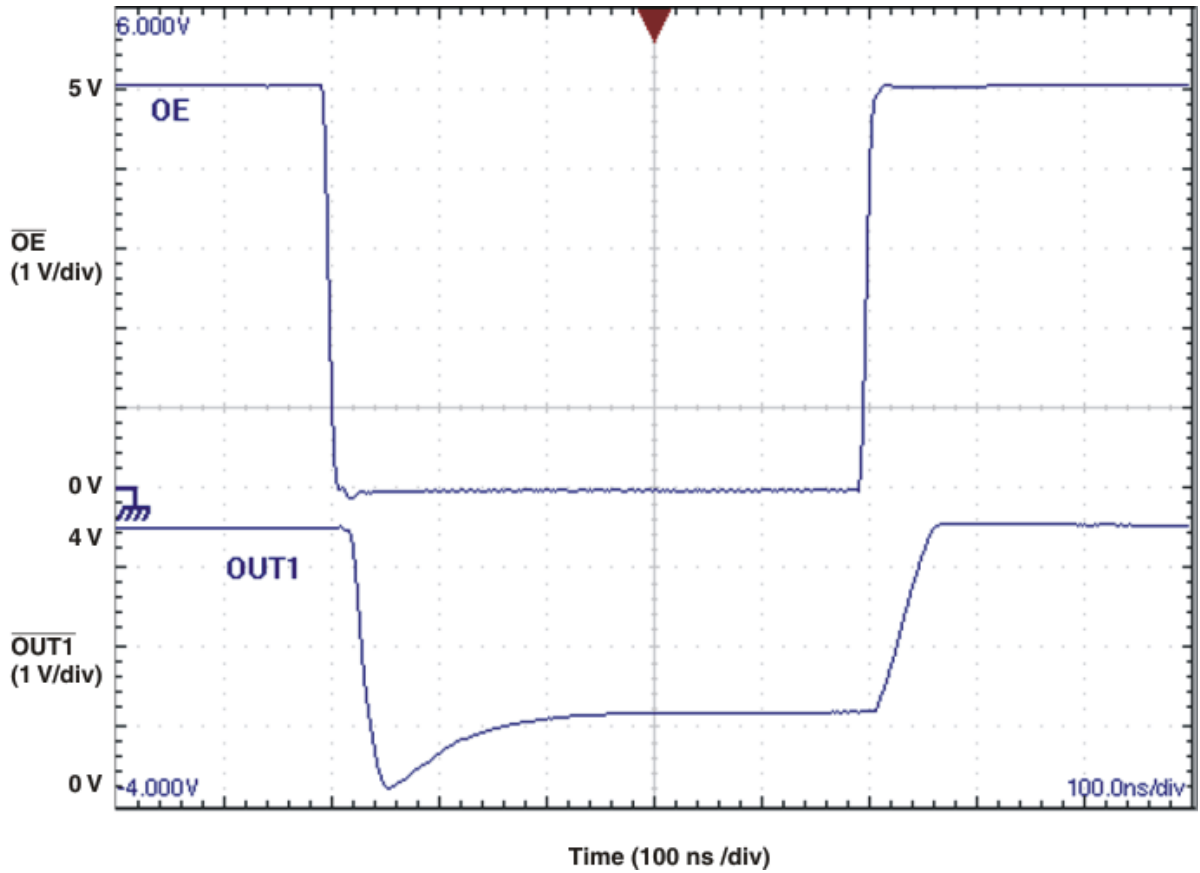

Figure 7. \overline{OE} to $\overline{OUT1}$

$V_{DD} = 5\text{ V}$
 $V_L = 4\text{ V}$
 $R_{ext} = 840\ \Omega$
 $R_L = 88\ \Omega$
 $C_L = 10\text{ pF}$

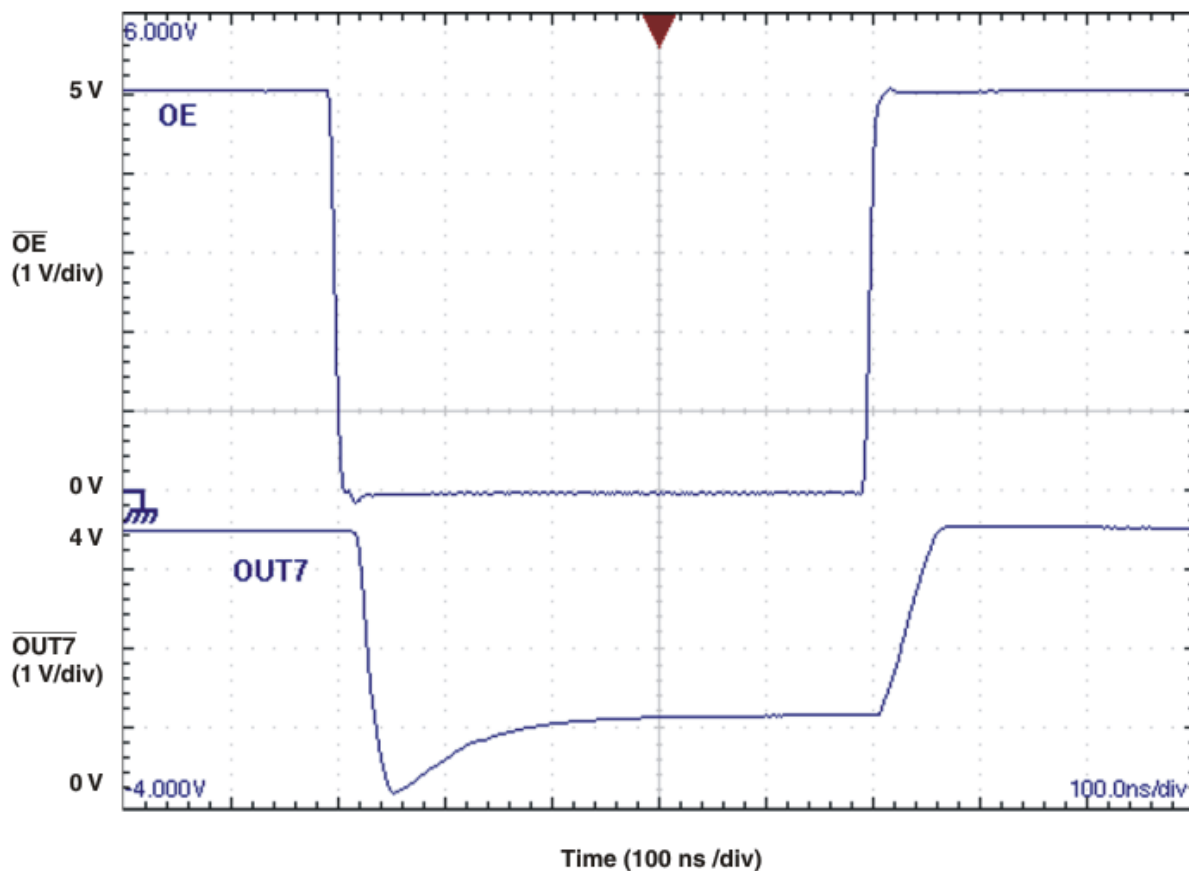

Figure 8. \overline{OE} to $\overline{OUT7}$

PACKAGING INFORMATION

Orderable Device	Status (1)	Package Type	Package Drawing	Pins	Package Qty	Eco Plan (2)	Lead/Ball Finish	MSL Peak Temp (3)	Op Temp (°C)	Device Marking (4/5)	Samples
TLC59025IDBQR	ACTIVE	SSOP	DBQ	24	2500	Green (RoHS & no Sb/Br)	CU NIPDAU	Level-2-260C-1 YEAR	-40 to 125	TLC59025I	Samples

(1) The marketing status values are defined as follows:

ACTIVE: Product device recommended for new designs.

LIFEBUY: TI has announced that the device will be discontinued, and a lifetime-buy period is in effect.

NRND: Not recommended for new designs. Device is in production to support existing customers, but TI does not recommend using this part in a new design.

PREVIEW: Device has been announced but is not in production. Samples may or may not be available.

OBSOLETE: TI has discontinued the production of the device.

(2) Eco Plan - The planned eco-friendly classification: Pb-Free (RoHS), Pb-Free (RoHS Exempt), or Green (RoHS & no Sb/Br) - please check <http://www.ti.com/productcontent> for the latest availability information and additional product content details.

TBD: The Pb-Free/Green conversion plan has not been defined.

Pb-Free (RoHS): TI's terms "Lead-Free" or "Pb-Free" mean semiconductor products that are compatible with the current RoHS requirements for all 6 substances, including the requirement that lead not exceed 0.1% by weight in homogeneous materials. Where designed to be soldered at high temperatures, TI Pb-Free products are suitable for use in specified lead-free processes.

Pb-Free (RoHS Exempt): This component has a RoHS exemption for either 1) lead-based flip-chip solder bumps used between the die and package, or 2) lead-based die adhesive used between the die and leadframe. The component is otherwise considered Pb-Free (RoHS compatible) as defined above.

Green (RoHS & no Sb/Br): TI defines "Green" to mean Pb-Free (RoHS compatible), and free of Bromine (Br) and Antimony (Sb) based flame retardants (Br or Sb do not exceed 0.1% by weight in homogeneous material)

(3) MSL, Peak Temp. -- The Moisture Sensitivity Level rating according to the JEDEC industry standard classifications, and peak solder temperature.

(4) There may be additional marking, which relates to the logo, the lot trace code information, or the environmental category on the device.

(5) Multiple Device Markings will be inside parentheses. Only one Device Marking contained in parentheses and separated by a "~" will appear on a device. If a line is indented then it is a continuation of the previous line and the two combined represent the entire Device Marking for that device.

Important Information and Disclaimer: The information provided on this page represents TI's knowledge and belief as of the date that it is provided. TI bases its knowledge and belief on information provided by third parties, and makes no representation or warranty as to the accuracy of such information. Efforts are underway to better integrate information from third parties. TI has taken and continues to take reasonable steps to provide representative and accurate information but may not have conducted destructive testing or chemical analysis on incoming materials and chemicals. TI and TI suppliers consider certain information to be proprietary, and thus CAS numbers and other limited information may not be available for release.

In no event shall TI's liability arising out of such information exceed the total purchase price of the TI part(s) at issue in this document sold by TI to Customer on an annual basis.

TAPE AND REEL INFORMATION



QUADRANT ASSIGNMENTS FOR PIN 1 ORIENTATION IN TAPE



*All dimensions are nominal

Device	Package Type	Package Drawing	Pins	SPQ	Reel Diameter (mm)	Reel Width W1 (mm)	A0 (mm)	B0 (mm)	K0 (mm)	P1 (mm)	W (mm)	Pin1 Quadrant
TLC59025IDBQR	SSOP	DBQ	24	2500	330.0	16.4	6.5	9.0	2.1	8.0	16.0	Q1

TAPE AND REEL BOX DIMENSIONS



*All dimensions are nominal

Device	Package Type	Package Drawing	Pins	SPQ	Length (mm)	Width (mm)	Height (mm)
TLC59025IDBQR	SSOP	DBQ	24	2500	367.0	367.0	38.0

DBQ (R-PDSO-G24)

PLASTIC SMALL OUTLINE PACKAGE

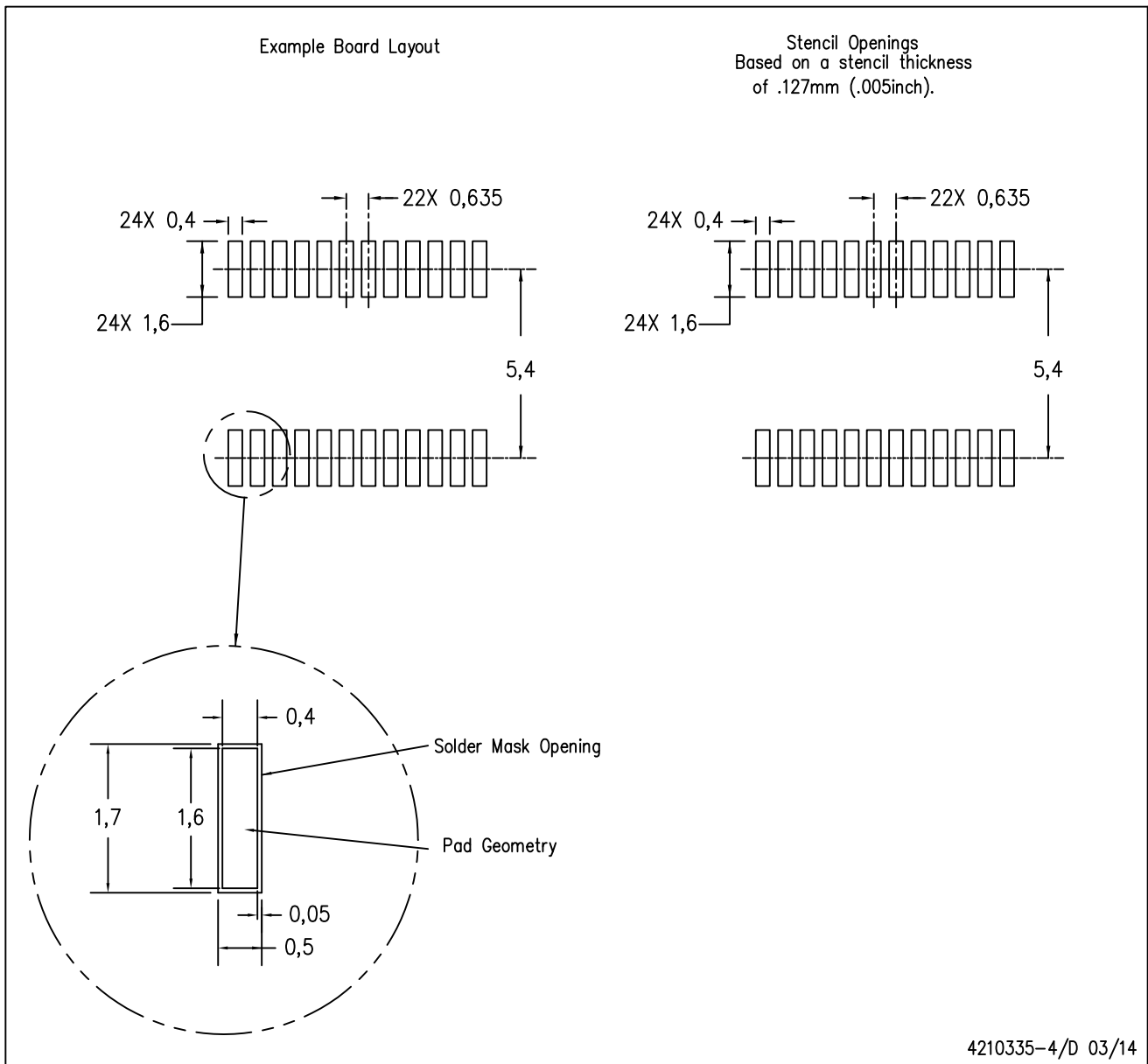

- NOTES:
- A. All linear dimensions are in millimeters.
 - B. This drawing is subject to change without notice.
 - C. Publication IPC-7351 is recommended for alternate designs.
 - D. Laser cutting apertures with trapezoidal walls and also rounding corners will offer better paste release. Customers should contact their board assembly site for stencil design recommendations. Example stencil design based on a 50% volumetric metal load solder paste. Refer to IPC-7525 for other stencil recommendations.

IMPORTANT NOTICE

Texas Instruments Incorporated and its subsidiaries (TI) reserve the right to make corrections, enhancements, improvements and other changes to its semiconductor products and services per JESD46, latest issue, and to discontinue any product or service per JESD48, latest issue. Buyers should obtain the latest relevant information before placing orders and should verify that such information is current and complete. All semiconductor products (also referred to herein as "components") are sold subject to TI's terms and conditions of sale supplied at the time of order acknowledgment.

TI warrants performance of its components to the specifications applicable at the time of sale, in accordance with the warranty in TI's terms and conditions of sale of semiconductor products. Testing and other quality control techniques are used to the extent TI deems necessary to support this warranty. Except where mandated by applicable law, testing of all parameters of each component is not necessarily performed.

TI assumes no liability for applications assistance or the design of Buyers' products. Buyers are responsible for their products and applications using TI components. To minimize the risks associated with Buyers' products and applications, Buyers should provide adequate design and operating safeguards.

TI does not warrant or represent that any license, either express or implied, is granted under any patent right, copyright, mask work right, or other intellectual property right relating to any combination, machine, or process in which TI components or services are used. Information published by TI regarding third-party products or services does not constitute a license to use such products or services or a warranty or endorsement thereof. Use of such information may require a license from a third party under the patents or other intellectual property of the third party, or a license from TI under the patents or other intellectual property of TI.

Reproduction of significant portions of TI information in TI data books or data sheets is permissible only if reproduction is without alteration and is accompanied by all associated warranties, conditions, limitations, and notices. TI is not responsible or liable for such altered documentation. Information of third parties may be subject to additional restrictions.

Resale of TI components or services with statements different from or beyond the parameters stated by TI for that component or service voids all express and any implied warranties for the associated TI component or service and is an unfair and deceptive business practice. TI is not responsible or liable for any such statements.

Buyer acknowledges and agrees that it is solely responsible for compliance with all legal, regulatory and safety-related requirements concerning its products, and any use of TI components in its applications, notwithstanding any applications-related information or support that may be provided by TI. Buyer represents and agrees that it has all the necessary expertise to create and implement safeguards which anticipate dangerous consequences of failures, monitor failures and their consequences, lessen the likelihood of failures that might cause harm and take appropriate remedial actions. Buyer will fully indemnify TI and its representatives against any damages arising out of the use of any TI components in safety-critical applications.

In some cases, TI components may be promoted specifically to facilitate safety-related applications. With such components, TI's goal is to help enable customers to design and create their own end-product solutions that meet applicable functional safety standards and requirements. Nonetheless, such components are subject to these terms.

No TI components are authorized for use in FDA Class III (or similar life-critical medical equipment) unless authorized officers of the parties have executed a special agreement specifically governing such use.

Only those TI components which TI has specifically designated as military grade or "enhanced plastic" are designed and intended for use in military/aerospace applications or environments. Buyer acknowledges and agrees that any military or aerospace use of TI components which have *not* been so designated is solely at the Buyer's risk, and that Buyer is solely responsible for compliance with all legal and regulatory requirements in connection with such use.

TI has specifically designated certain components as meeting ISO/TS16949 requirements, mainly for automotive use. In any case of use of non-designated products, TI will not be responsible for any failure to meet ISO/TS16949.

Products

Audio	www.ti.com/audio
Amplifiers	amplifier.ti.com
Data Converters	dataconverter.ti.com
DLP® Products	www.dlp.com
DSP	dsp.ti.com
Clocks and Timers	www.ti.com/clocks
Interface	interface.ti.com
Logic	logic.ti.com
Power Mgmt	power.ti.com
Microcontrollers	microcontroller.ti.com
RFID	www.ti-rfid.com
OMAP Applications Processors	www.ti.com/omap
Wireless Connectivity	www.ti.com/wirelessconnectivity

Applications

Automotive and Transportation	www.ti.com/automotive
Communications and Telecom	www.ti.com/communications
Computers and Peripherals	www.ti.com/computers
Consumer Electronics	www.ti.com/consumer-apps
Energy and Lighting	www.ti.com/energy
Industrial	www.ti.com/industrial
Medical	www.ti.com/medical
Security	www.ti.com/security
Space, Avionics and Defense	www.ti.com/space-avionics-defense
Video and Imaging	www.ti.com/video

TI E2E Community

e2e.ti.com