

# TL494 PULSE-WIDTH-MODULATION CONTROL CIRCUITS

SLVS074D – JANUARY 1983 – REVISED MAY 2002

- Complete PWM Power-Control Circuitry
- Uncommitted Outputs for 200-mA Sink or Source Current
- Output Control Selects Single-Ended or Push-Pull Operation
- Internal Circuitry Prohibits Double Pulse at Either Output
- Variable Dead Time Provides Control Over Total Range
- Internal Regulator Provides a Stable 5-V Reference Supply With 5% Tolerance
- Circuit Architecture Allows Easy Synchronization

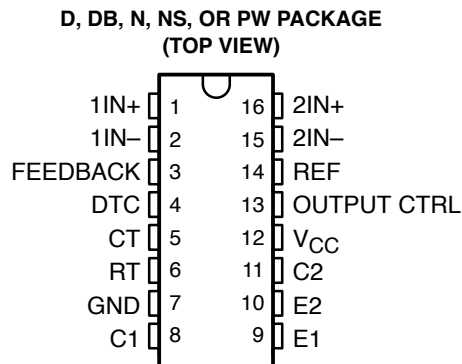

## description

The TL494 incorporates all the functions required in the construction of a pulse-width-modulation (PWM) control circuit on a single chip. Designed primarily for power-supply control, this device offers the flexibility to tailor the power-supply control circuitry to a specific application.

The TL494 contains two error amplifiers, an on-chip adjustable oscillator, a dead-time control (DTC) comparator, a pulse-steering control flip-flop, a 5-V, 5%-precision regulator, and output-control circuits.

The error amplifiers exhibit a common-mode voltage range from  $-0.3\text{ V}$  to  $V_{CC} - 2\text{ V}$ . The dead-time control comparator has a fixed offset that provides approximately 5% dead time. The on-chip oscillator can be bypassed by terminating RT to the reference output and providing a sawtooth input to CT, or it can drive the common circuits in synchronous multiple-rail power supplies.

The uncommitted output transistors provide either common-emitter or emitter-follower output capability. The TL494 provides for push-pull or single-ended output operation, which can be selected through the output-control function. The architecture of this device prohibits the possibility of either output being pulsed twice during push-pull operation.

The TL494C is characterized for operation from  $0^{\circ}\text{C}$  to  $70^{\circ}\text{C}$ . The TL494I is characterized for operation from  $-40^{\circ}\text{C}$  to  $85^{\circ}\text{C}$ .

### AVAILABLE OPTIONS

T <sub>A</sub>	PACKAGED DEVICES				
	SMALL OUTLINE (D)	PLASTIC DIP (N)	SMALL OUTLINE (NS)	SHRINK SMALL OUTLINE (DB)	THIN SHRINK SMALL OUTLINE (PW)
$0^{\circ}\text{C}$ to $70^{\circ}\text{C}$	TL494CD	TL494CN	TL494CNS	TL494CDB	TL494CPW
$-40^{\circ}\text{C}$ to $85^{\circ}\text{C}$	TL494ID	TL494IN	—	—	—

The D, DB, NS, and PW packages are available taped and reeled. Add the suffix R to device type (e.g., TL494CDR).



Please be aware that an important notice concerning availability, standard warranty, and use in critical applications of Texas Instruments semiconductor products and disclaimers thereto appears at the end of this data sheet.

PRODUCTION DATA information is current as of publication date. Products conform to specifications per the terms of Texas Instruments standard warranty. Production processing does not necessarily include testing of all parameters.

**TEXAS  
INSTRUMENTS**

POST OFFICE BOX 655303 • DALLAS, TEXAS 75265

Copyright © 2002, Texas Instruments Incorporated

# TL494

## PULSE-WIDTH-MODULATION CONTROL CIRCUITS

SLVS074D – JANUARY 1983 – REVISED MAY 2002

FUNCTION TABLE

INPUT TO OUTPUT CTRL	OUTPUT FUNCTION
$V_I = \text{GND}$	Single-ended or parallel output
$V_I = V_{\text{ref}}$	Normal push-pull operation

### functional block diagram

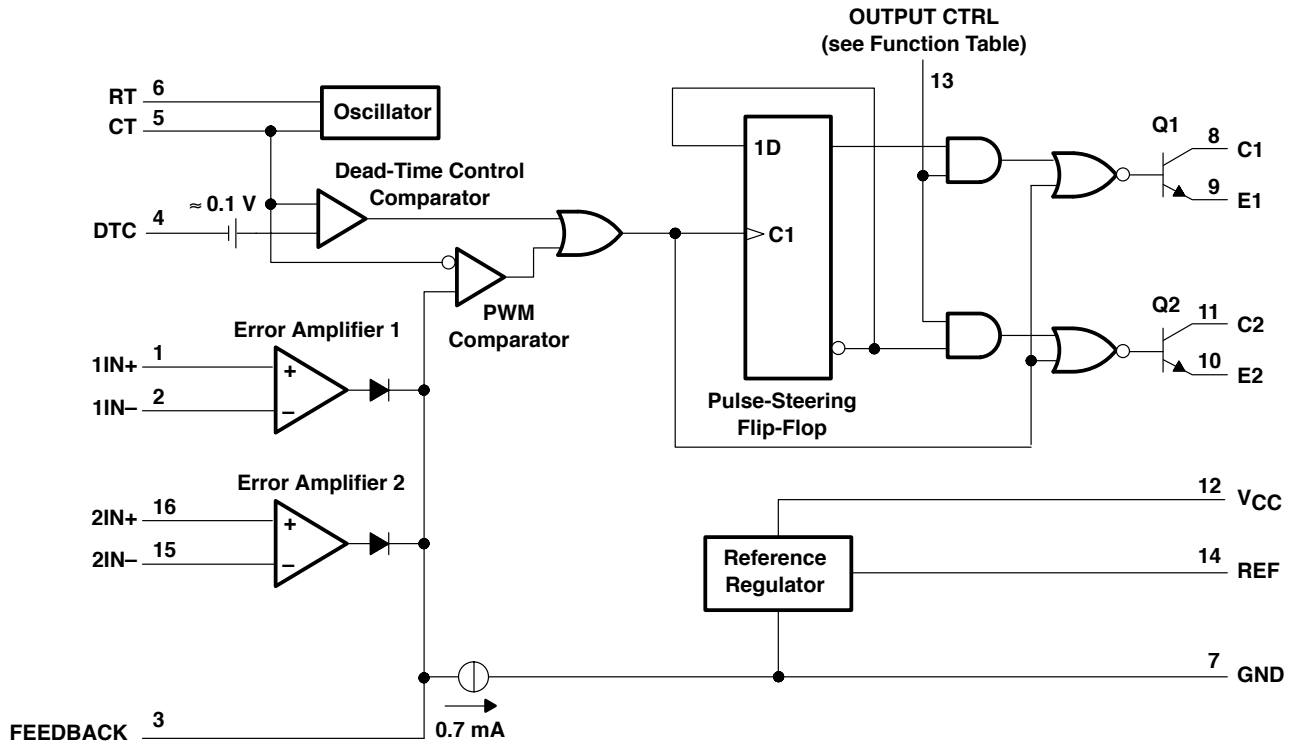

# TL494 PULSE-WIDTH-MODULATION CONTROL CIRCUITS

SLVS074D – JANUARY 1983 – REVISED MAY 2002

## absolute maximum ratings over operating free-air temperature range (unless otherwise noted)†

Supply voltage, $V_{CC}$ (see Note 1)	41 V	
Amplifier input voltage, $V_I$	$V_{CC} + 0.3$ V	
Collector output voltage, $V_O$	41 V	
Collector output current, $I_O$	250 mA	
Package thermal impedance, $\theta_{JA}$ (see Note 2 and 3):	D package	73°C/W
	DB package	82°C/W
	N package	67°C/W
	NS package	64°C/W
	PW package	108°C/W
Lead temperature 1,6 mm (1/16 inch) from case for 10 seconds	260°C	
Storage temperature range, $T_{stg}$	–65°C to 150°C	

† Stresses beyond those listed under “absolute maximum ratings” may cause permanent damage to the device. These are stress ratings only, and functional operation of the device at these or any other conditions beyond those indicated under “recommended operating conditions” is not implied. Exposure to absolute-maximum-rated conditions for extended periods may affect device reliability.

- NOTES:
1. All voltage values are with respect to the network ground terminal.
  2. Maximum power dissipation is a function of  $T_J(\max)$ ,  $\theta_{JA}$ , and  $T_A$ . The maximum allowable power dissipation at any allowable ambient temperature is  $P_D = (T_J(\max) - T_A)/\theta_{JA}$ . Operating at the absolute maximum  $T_J$  of 150°C can affect reliability.
  3. The package thermal impedance is calculated in accordance with JESD 51-7.

## recommended operating conditions

		MIN	MAX	UNIT	
$V_{CC}$	Supply voltage	7	40	V	
$V_I$	Amplifier input voltage	–0.3	$V_{CC} - 2$	V	
$V_O$	Collector output voltage		40	V	
	Collector output current (each transistor)		200	mA	
	Current into feedback terminal		0.3	mA	
$f_{osc}$	Oscillator frequency	1	300	kHz	
$C_T$	Timing capacitor	0.47	10000	nF	
$R_T$	Timing resistor	1.8	500	k $\Omega$	
$T_A$	Operating free-air temperature	TL494C	0	70	°C
		TL494I	–40	85	

# TL494

## PULSE-WIDTH-MODULATION CONTROL CIRCUITS

SLVS074D – JANUARY 1983 – REVISED MAY 2002

electrical characteristics over recommended operating free-air temperature range,  $V_{CC} = 15\text{ V}$ ,  $f = 10\text{ kHz}$  (unless otherwise noted)

### reference section

PARAMETER	TEST CONDITIONS†	TL494C, TL494I			UNIT
		MIN	TYP‡	MAX	
Output voltage (REF)	$I_O = 1\text{ mA}$	4.75	5	5.25	V
Input regulation	$V_{CC} = 7\text{ V to }40\text{ V}$		2	25	mV
Output regulation	$I_O = 1\text{ mA to }10\text{ mA}$		1	15	mV
Output voltage change with temperature	$\Delta T_A = \text{MIN to MAX}$		2	10	mV/V
Short-circuit output current§	REF = 0 V		25		mA

† For conditions shown as MIN or MAX, use the appropriate value specified under recommended operating conditions.

‡ All typical values, except for parameter changes with temperature, are at  $T_A = 25^\circ\text{C}$ .

§ Duration of the short circuit should not exceed one second.

### oscillator section, $C_T = 0.01\ \mu\text{F}$ , $R_T = 12\text{ k}\Omega$ (see Figure 1)

PARAMETER	TEST CONDITIONS†	TL494, TL494I			UNIT
		MIN	TYP‡	MAX	
Frequency			10		kHz
Standard deviation of frequency¶	All values of $V_{CC}$ , $C_T$ , $R_T$ , and $T_A$ constant		100		Hz/kHz
Frequency change with voltage	$V_{CC} = 7\text{ V to }40\text{ V}$ , $T_A = 25^\circ\text{C}$		1		Hz/kHz
Frequency change with temperature#	$\Delta T_A = \text{MIN to MAX}$			10	Hz/kHz

† For conditions shown as MIN or MAX, use the appropriate value specified under recommended operating conditions.

‡ All typical values, except for parameter changes with temperature, are at  $T_A = 25^\circ\text{C}$ .

¶ Standard deviation is a measure of the statistical distribution about the mean as derived from the formula:

$$\sigma = \sqrt{\frac{\sum_{n=1}^N (x_n - \bar{X})^2}{N - 1}}$$

# Temperature coefficient of timing capacitor and timing resistor are not taken into account.

### error-amplifier section (see Figure 2)

PARAMETER	TEST CONDITIONS	TL494, TL494I			UNIT
		MIN	TYP‡	MAX	
Input offset voltage	$V_O (\text{FEEDBACK}) = 2.5\text{ V}$		2	10	mV
Input offset current	$V_O (\text{FEEDBACK}) = 2.5\text{ V}$		25	250	nA
Input bias current	$V_O (\text{FEEDBACK}) = 2.5\text{ V}$		0.2	1	$\mu\text{A}$
Common-mode input voltage range	$V_{CC} = 7\text{ V to }40\text{ V}$	-0.3 to $V_{CC}-2$			V
Open-loop voltage amplification	$\Delta V_O = 3\text{ V}$ , $R_L = 2\text{ k}\Omega$ , $V_O = 0.5\text{ V to }3.5\text{ V}$	70	95		dB
Unity-gain bandwidth	$V_O = 0.5\text{ V to }3.5\text{ V}$ , $R_L = 2\text{ k}\Omega$		800		kHz
Common-mode rejection ratio	$\Delta V_O = 40\text{ V}$ , $T_A = 25^\circ\text{C}$	65	80		dB
Output sink current (FEEDBACK)	$V_{ID} = -15\text{ mV to }-5\text{ V}$ , $V (\text{FEEDBACK}) = 0.7\text{ V}$	0.3	0.7		mA
Output source current (FEEDBACK)	$V_{ID} = 15\text{ mV to }5\text{ V}$ , $V (\text{FEEDBACK}) = 3.5\text{ V}$	-2			mA

‡ All typical values, except for parameter changes with temperature, are at  $T_A = 25^\circ\text{C}$ .



**electrical characteristics over recommended operating free-air temperature range,  $V_{CC} = 15\text{ V}$ ,  $f = 10\text{ kHz}$  (unless otherwise noted)**

**output section**

PARAMETER	TEST CONDITIONS	MIN	TYP†	MAX	UNIT
Collector off-state current	$V_{CE} = 40\text{ V}$ , $V_{CC} = 40\text{ V}$		2	100	$\mu\text{A}$
Emitter off-state current	$V_{CC} = V_C = 40\text{ V}$ , $V_E = 0$			-100	$\mu\text{A}$
Collector-emitter saturation voltage	Common emitter $V_E = 0$ , $I_C = 200\text{ mA}$		1.1	1.3	V
	Emitter follower $V_{O(C1\text{ or }C2)} = 15\text{ V}$ , $I_E = -200\text{ mA}$		1.5	2.5	
Output control input current	$V_I = V_{ref}$			3.5	mA

† All typical values except for temperature coefficient are at  $T_A = 25^\circ\text{C}$ .

**dead-time control section (see Figure 1)**

PARAMETER	TEST CONDITIONS	MIN	TYP†	MAX	UNIT
Input bias current (DEAD-TIME CTRL)	$V_I = 0$ to $5.25\text{ V}$		-2	-10	$\mu\text{A}$
Maximum duty cycle, each output	$V_I$ (DEAD-TIME CTRL) = 0, $C_T = 0.01\ \mu\text{F}$ , $R_T = 12\text{ k}\Omega$		45%		
Input threshold voltage (DEAD-TIME CTRL)	Zero duty cycle		3	3.3	V
	Maximum duty cycle	0			

† All typical values except for temperature coefficient are at  $T_A = 25^\circ\text{C}$ .

**PWM comparator section (see Figure 1)**

PARAMETER	TEST CONDITIONS	MIN	TYP†	MAX	UNIT
Input threshold voltage (FEEDBACK)	Zero duty cycle		4	4.5	V
Input sink current (FEEDBACK)	$V$ (FEEDBACK) = $0.7\text{ V}$	0.3	0.7		mA

† All typical values except for temperature coefficient are at  $T_A = 25^\circ\text{C}$ .

**total device**

PARAMETER	TEST CONDITIONS	MIN	TYP†	MAX	UNIT
Standby supply current	$R_T = V_{ref}$ , All other inputs and outputs open	$V_{CC} = 15\text{ V}$	6	10	mA
		$V_{CC} = 40\text{ V}$	9	15	
Average supply current	$V_I$ (DEAD-TIME CTRL) = $2\text{ V}$ , See Figure 1		7.5		mA

† All typical values except for temperature coefficient are at  $T_A = 25^\circ\text{C}$ .

**switching characteristics,  $T_A = 25^\circ\text{C}$**

PARAMETER	TEST CONDITIONS	MIN	TYP†	MAX	UNIT
Rise time	Common-emitter configuration, See Figure 3		100	200	ns
Fall time			25	100	ns
Rise time	Emitter-follower configuration, See Figure 4		100	200	ns
Fall time			40	100	ns

† All typical values except for temperature coefficient are at  $T_A = 25^\circ\text{C}$ .

# TL494 PULSE-WIDTH-MODULATION CONTROL CIRCUITS

SLVS074D – JANUARY 1983 – REVISED MAY 2002

## PARAMETER MEASUREMENT INFORMATION

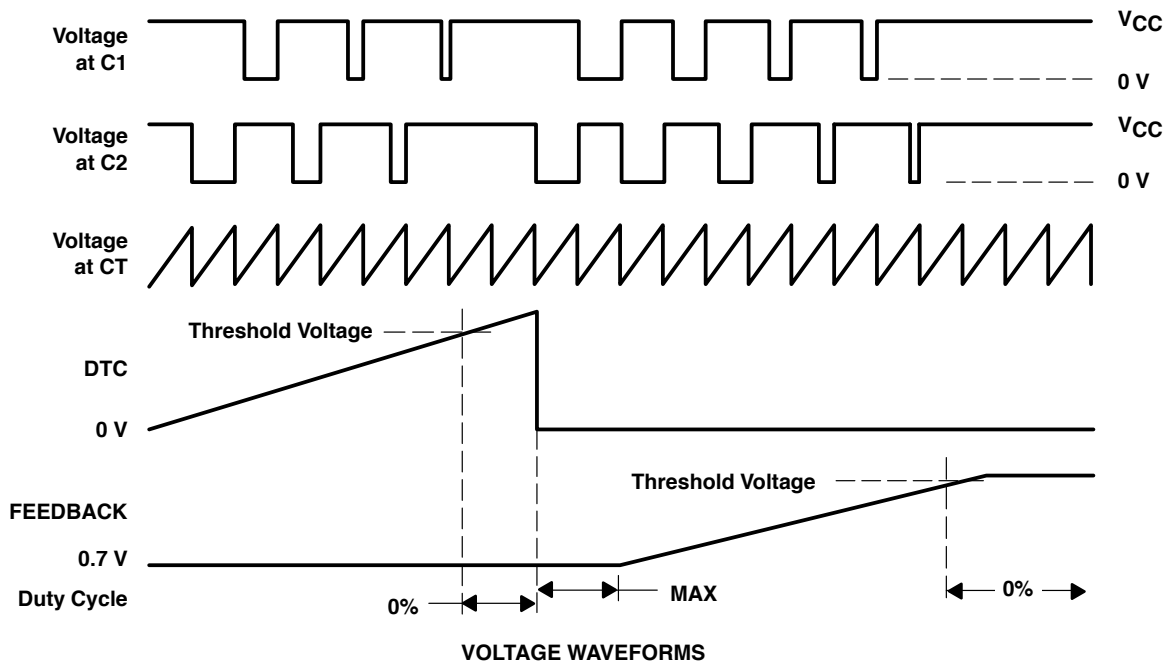
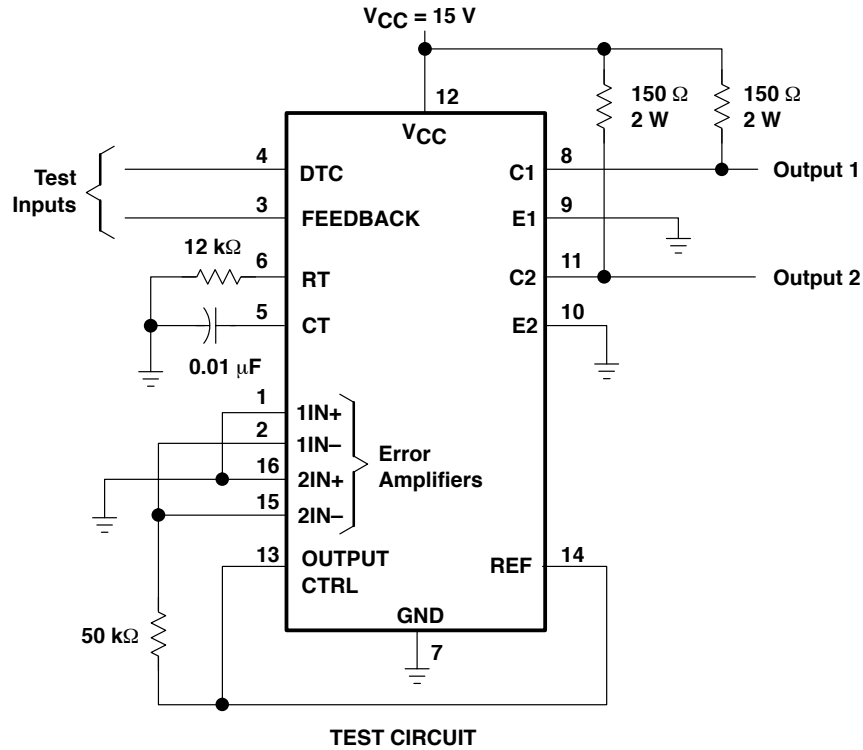

Figure 1. Operational Test Circuit and Waveforms

PARAMETER MEASUREMENT INFORMATION

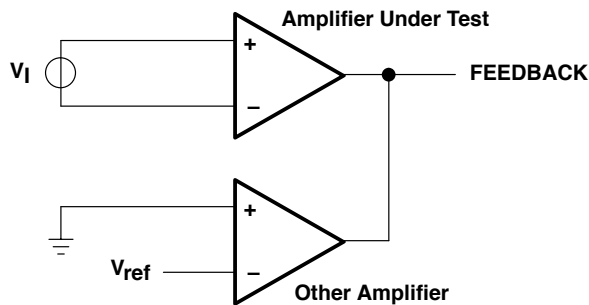
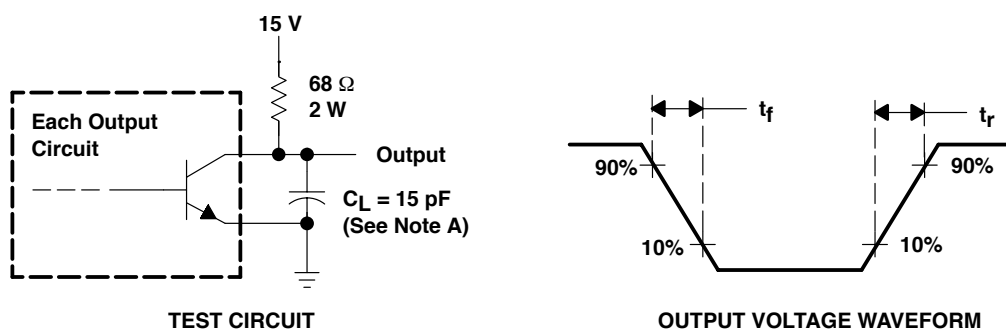
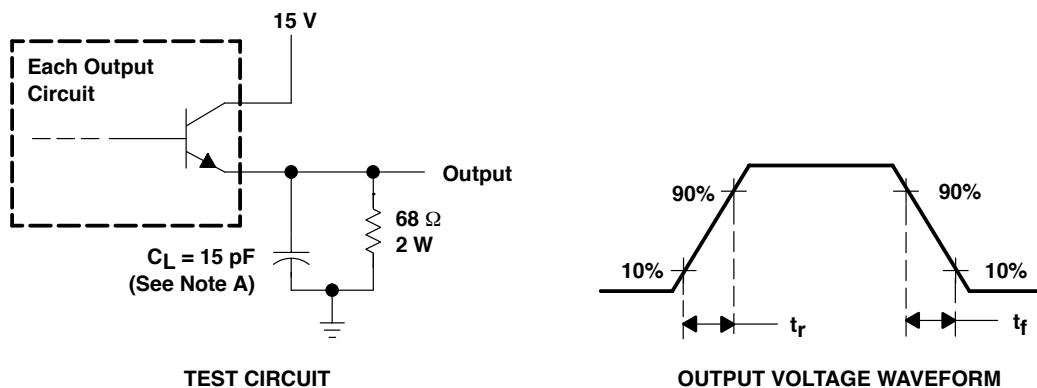

Figure 2. Amplifier Characteristics



NOTE A:  $C_L$  includes probe and jig capacitance.

Figure 3. Common-Emitter Configuration



NOTE A:  $C_L$  includes probe and jig capacitance.

Figure 4. Emitter-Follower Configuration

**TYPICAL CHARACTERISTICS**

**OSCILLATOR FREQUENCY AND  
 FREQUENCY VARIATION†**

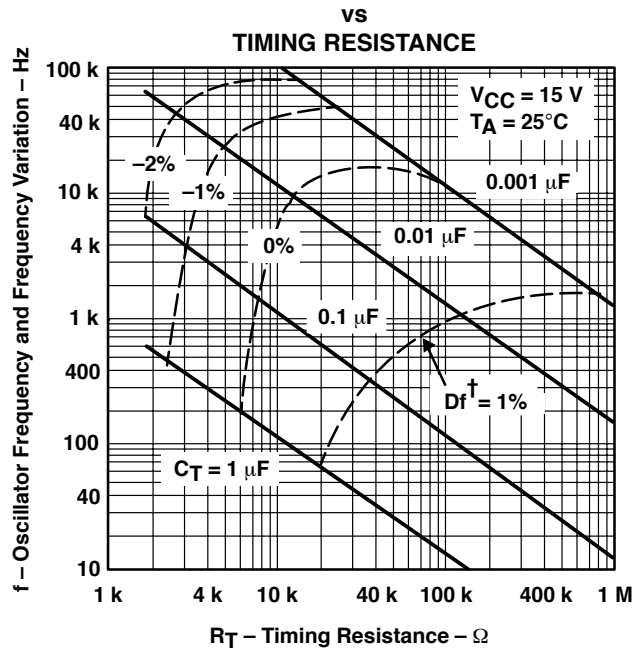

† Frequency variation ( $\Delta f$ ) is the change in oscillator frequency that occurs over the full temperature range.

**Figure 5**

**AMPLIFIER VOLTAGE AMPLIFICATION  
 vs  
 FREQUENCY**

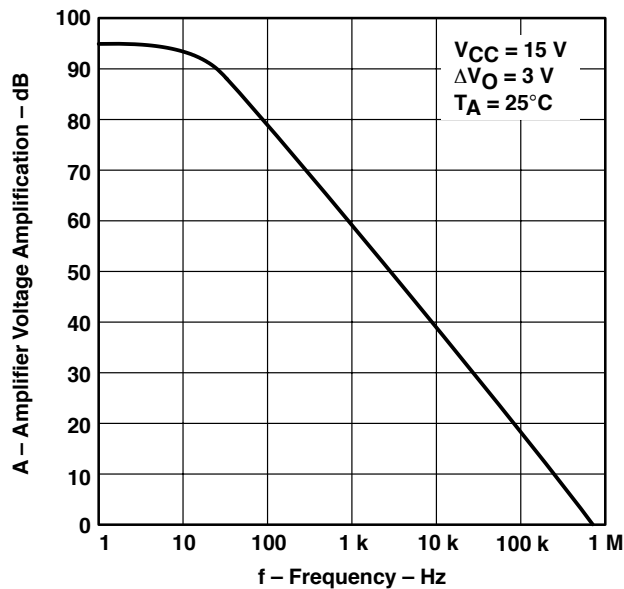

**Figure 6**

## IMPORTANT NOTICE

Texas Instruments Incorporated and its subsidiaries (TI) reserve the right to make corrections, modifications, enhancements, improvements, and other changes to its products and services at any time and to discontinue any product or service without notice. Customers should obtain the latest relevant information before placing orders and should verify that such information is current and complete. All products are sold subject to TI's terms and conditions of sale supplied at the time of order acknowledgment.

TI warrants performance of its hardware products to the specifications applicable at the time of sale in accordance with TI's standard warranty. Testing and other quality control techniques are used to the extent TI deems necessary to support this warranty. Except where mandated by government requirements, testing of all parameters of each product is not necessarily performed.

TI assumes no liability for applications assistance or customer product design. Customers are responsible for their products and applications using TI components. To minimize the risks associated with customer products and applications, customers should provide adequate design and operating safeguards.

TI does not warrant or represent that any license, either express or implied, is granted under any TI patent right, copyright, mask work right, or other TI intellectual property right relating to any combination, machine, or process in which TI products or services are used. Information published by TI regarding third-party products or services does not constitute a license from TI to use such products or services or a warranty or endorsement thereof. Use of such information may require a license from a third party under the patents or other intellectual property of the third party, or a license from TI under the patents or other intellectual property of TI.

Reproduction of information in TI data books or data sheets is permissible only if reproduction is without alteration and is accompanied by all associated warranties, conditions, limitations, and notices. Reproduction of this information with alteration is an unfair and deceptive business practice. TI is not responsible or liable for such altered documentation.

Resale of TI products or services with statements different from or beyond the parameters stated by TI for that product or service voids all express and any implied warranties for the associated TI product or service and is an unfair and deceptive business practice. TI is not responsible or liable for any such statements.

### Mailing Address:

Texas Instruments  
Post Office Box 655303  
Dallas, Texas 75265