

# THS1030 3-V TO 5.5-V, 10-BIT, 30 MSPS CMOS ANALOG-TO-DIGITAL CONVERTER

SLAS243E – NOVEMBER 1999 – REVISED DECEMBER 2003

- **10-Bit Resolution, 30 MSPS Analog-to-Digital Converter**
- **Configurable Input: Single-Ended or Differential**
- **Differential Nonlinearity:  $\pm 0.3$  LSB**
- **Signal-to-Noise: 57 dB**
- **Spurious Free Dynamic Range: 60 dB**
- **Adjustable Internal Voltage Reference**
- **Out-of-Range Indicator**
- **Power-Down Mode**
- **Pin Compatible With TLC876**

28-PIN TSSOP/SOIC PACKAGE  
(TOP VIEW)

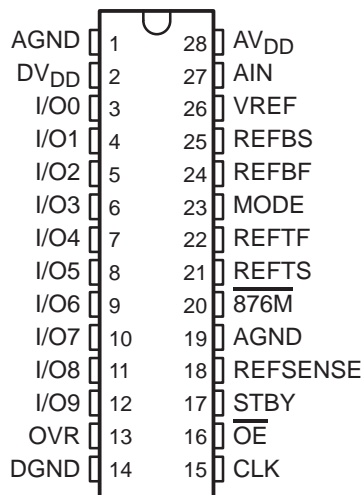

## description

The THS1030 is a CMOS, low-power, 10-bit, 30 MSPS analog-to-digital converter (ADC) that can operate with a supply range from 3 V to 5.5 V. The THS1030 has been designed to give circuit developers flexibility. The analog input to the THS1030 can be either single-ended or differential. The THS1030 provides a wide selection of voltage references to match the user's design requirements. For more design flexibility, the internal reference can be bypassed to use an external reference to suit the dc accuracy and temperature drift requirements of the application. The out-of-range output is used to monitor any out-of-range condition in THS1030's input range.

The speed, resolution, and single-supply operation of the THS1030 are suited for applications in STB, video, multimedia, imaging, high-speed acquisition, and communications. The speed and resolution ideally suit charge-couple device (CCD) input systems such as color scanners, digital copiers, digital cameras, and camcorders. A wide input voltage range between REFBS and REFTS allows the THS1030 to be applied in both imaging and communications systems.

The THS1030C is characterized for operation from 0°C to 70°C, while the THS1030I is characterized for operation from -40°C to 85°C

## AVAILABLE OPTIONS

PRODUCT	PACKAGE LEAD	PACKAGE DESIGNATOR†	SPECIFIED TEMPERATURE RANGE	PACKAGE MARKINGS	ORDERING NUMBER	TRANSPORT MEDIA, QUANTITY		
THS1030C	TSSOP-28	PW	0°C to 70°C	TH1030	THS1030CPW	Tube, 50		
					THS1030CPWR	Tube and Reel, 2000		
THS1030I	TSSOP-28	PW	-40°C to 85°C	TJ1030	THS1030IPW	Tube, 50		
					THS1030IPWR	Tube and Reel, 2000		
THS1030C	SOP-28	DW	0°C to 70°C	TH1030	THS1030CDW	Tube, 20		
					THS1030CDWR	Tube and Reel, 1000		
THS1030I			SOP-28	DW	-40°C to 85°C	TJ1030	THS1030IDW	Tube, 20
							THS1030IDWR	Tube and Reel, 1000

† For the most current specification and package information, refer to the TI web site at [www.ti.com](http://www.ti.com).



Please be aware that an important notice concerning availability, standard warranty, and use in critical applications of Texas Instruments semiconductor products and disclaimers thereto appears at the end of this data sheet.

PRODUCTION DATA information is current as of publication date. Products conform to specifications per the terms of Texas Instruments standard warranty. Production processing does not necessarily include testing of all parameters.

 **TEXAS  
INSTRUMENTS**

POST OFFICE BOX 655303 • DALLAS, TEXAS 75265

Copyright © 1999 – 2003, Texas Instruments Incorporated

**THS1030**  
**3-V TO 5.5-V, 10-BIT, 30 MSPS**  
**CMOS ANALOG-TO-DIGITAL CONVERTER**

SLAS243E – NOVEMBER 1999 – REVISED DECEMBER 2003

**functional block diagram**

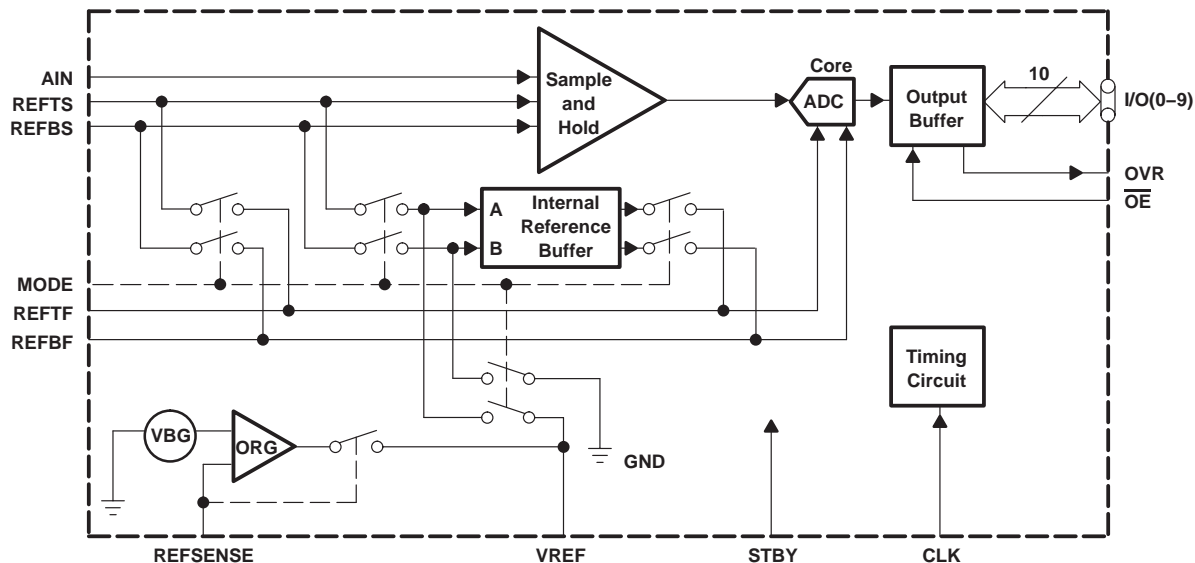

**Terminal Functions**

TERMINAL NAME	NO.	I/O	DESCRIPTION
AGND	1, 19	I	Analog ground
AIN	27	I	Analog input
AVDD	28	I	Analog supply
CLK	15	I	Clock input
DGND	14	I	Digital ground
DVDD	2	I	Digital driver supply
I/O0	3	O	Digital I/O bit 0 (LSB)
I/O1	4		Digital I/O bit 1
I/O2	5		Digital I/O bit 2
I/O3	6		Digital I/O bit 3
I/O4	7		Digital I/O bit 4
I/O5	8		Digital I/O bit 5
I/O6	9		Digital I/O bit 6
I/O7	10		Digital I/O bit 7
I/O8	11		Digital I/O bit 8
I/O9	12		Digital I/O bit 9 (MSB)
MODE	23	I	Mode input
OE	16	I	High to 3-state the data bus, low to enable the data bus
OVR	13	O	Out-of-range indicator
REFBS	25	I	Reference bottom sense
REFBF	24	I	Reference bottom decoupling
REFSENSE	18	I	Reference sense
REFTF	22	I	Reference top decoupling
REFTS	21	I	Reference top sense
STBY	17	I	High = power-down mode, low = normal operation mode
VREF	26	I/O	Internal and external reference
876M	20	I	High = THS1030 mode, low = TLC876 mode (see section 4 for TLC876 mode)



**absolute maximum ratings over operating free-air temperature (unless otherwise noted)†**

Supply voltage range: $AV_{DD}$ to AGND, $DV_{DD}$ to DGND	-0.3 V to 6.5 V
AGND to DGND	-0.3 V to 0.3 V
$AV_{DD}$ to $DV_{DD}$	-6.5 V to 6.5 V
Mode input voltage range, MODE to AGND	-0.3 V to $AV_{DD} + 0.3$ V
Reference voltage input range, REFTF, REFTB, REFTS, REFBS to AGND	-0.3 V to $AV_{DD} + 0.3$ V
Analog input voltage range, AIN to AGND	-0.3 V to $AV_{DD} + 0.3$ V
Reference input voltage range, VREF to AGND	-0.3 V to $AV_{DD} + 0.3$ V
Reference output voltage range, VREF to AGND	-0.3 V to $AV_{DD} + 0.3$ V
Clock input voltage range, CLK to AGND	-0.3 V to $AV_{DD} + 0.3$ V
Digital input voltage range, digital input to DGND	-0.3 V to $DV_{DD} + 0.3$ V
Digital output voltage range, digital output to DGND	-0.3 V to $DV_{DD} + 0.3$ V
Operating junction temperature range, $T_J$	0°C to 150°C
Storage temperature range, $T_{stg}$	-65°C to 150°C
Lead temperature 1,6 mm (1/16 in) from case for 10 seconds	300°C

† Stresses beyond those listed under “absolute maximum ratings” may cause permanent damage to the device. These are stress ratings only, and functional operation of the device at these or any other conditions beyond those indicated under “recommended operating conditions” is not implied. Exposure to absolute-maximum-rated conditions for extended periods may affect device reliability.

**recommended operating conditions**

**digital inputs**

		MIN	NOM	MAX	UNIT
High-level input voltage, $V_{IH}$	Clock input	$0.8 \times AV_{DD}$			V
	All other inputs	$0.8 \times DV_{DD}$			
Low-level input voltage, $V_{IL}$	Clock input	$0.2 \times AV_{DD}$			V
	All other inputs	$0.2 \times DV_{DD}$			

**analog inputs**

		MIN	NOM	MAX	UNIT
Analog input voltage, $V_{I(AIN)}$		REFBS		REFTS	V
Reference input voltage	$V_{I(VREF)}$	1		2	V
	$V_{I(REFTS)}$	1		$AV_{DD}$	V
	$V_{I(REFBS)}$	0		$AV_{DD}-1$	V

**power supply**

		MIN	NOM	MAX	UNIT	
Supply voltage	Maximum sampling rate = 30 MSPS	$AV_{DD}$	3	3.3	5.5	V
		$DV_{DD}$	3	3.3	5.5	

**REFTS, REFBS reference voltages (MODE =  $AV_{DD}$ )**

		MIN	NOM	MAX	UNIT
Reference input voltage (top)	REFTS	1		$AV_{DD}$	V
Reference input voltage (bottom)	REFBS	0		$AV_{DD}-1$	V
Differential input voltage (REFTS – REFBS)		1		2	V
Switched sampling input capacitance on REFTS or REFBS			0.6		pF

**THS1030**  
**3-V TO 5.5-V, 10-BIT, 30 MSPS**  
**CMOS ANALOG-TO-DIGITAL CONVERTER**

SLAS243E – NOVEMBER 1999 – REVISED DECEMBER 2003

**recommended operating conditions (continued)**

**sampling rate and resolution**

PARAMETER		MIN	NOM	MAX	UNIT
$f_s$	Sample frequency	5		30	MSPS
	Resolution		10		Bits

**electrical characteristics over recommended operating conditions,  $AV_{DD} = 3\text{ V}$ ,  $DV_{DD} = 3\text{ V}$ ,  $f_s = 30\text{ MSPS}$ /50% duty cycle,  $MODE = AV_{DD}$ , 2-V input span from 0.5 V to 2.5 V, external reference,  $T_A = T_{min}$  to  $T_{max}$  (unless otherwise noted)**

**analog inputs**

PARAMETER		MIN	TYP	MAX	UNIT
$V_I(AIN)$	Analog input voltage	REFBS		REFTS	V
$C_I$	Switched sampling input capacitance		1.2		pF
BW	Full power bandwidth (–3 dB)		150		MHz
$I_{IKG}$	DC leakage current (input = $\pm FS$ )		60		$\mu A$

**VREF reference voltages**

PARAMETER		MIN	TYP	MAX	UNIT
	Internal 1-V reference voltage (REFSENSE = VREF)	0.95	1	1.05	V
	Internal 2-V reference voltage (REFSENSE = AGND)	1.90	2	2.10	V
	External reference voltage (REFSENSE = $AV_{DD}$ )	1		2	V
	Reference input resistance		680		$\Omega$

**REFTF, REFBF reference voltages**

PARAMETER		TEST CONDITIONS	MIN	TYP	MAX	UNIT
Differential input voltage (REFTF – REFBF) (REFSENSE = VREF)			0.9	1	1.1	V
Differential input voltage (REFTF – REFBF) (REFSENSE = AGND)			1.9	2	2.1	V
Input common mode voltage (REFTF + REFBF)/2		$AV_{DD} = 3\text{ V}$	1.3	1.5	1.7	V
		$AV_{DD} = 5\text{ V}$	2	2.5	3	
REFTF voltage (MODE = $AV_{DD}$ )	VREF = 1 V	$AV_{DD} = 3\text{ V}$	2		V	
		$AV_{DD} = 5\text{ V}$	3			
	VREF = 2 V	$AV_{DD} = 3\text{ V}$	2.5		V	
		$AV_{DD} = 5\text{ V}$	3.5			
REFBF voltage (MODE = $AV_{DD}$ )	VREF = 1 V	$AV_{DD} = 3\text{ V}$	1		V	
		$AV_{DD} = 5\text{ V}$	2			
	VREF = 2 V	$AV_{DD} = 3\text{ V}$	0.5		V	
		$AV_{DD} = 5\text{ V}$	1.5			
Input resistance between REFTF and REFBF			600		$\Omega$	
Power up time for valid ADC conversions ( $t_{PUconv}$ )		See Note 1	1.2		$\mu s$	

NOTES: 1. Time from control register STBY pin returning low to the ADC conversion to be accurate within 0.1% of fullscale.



**THS1030**  
**3-V TO 5.5-V, 10-BIT, 30 MSPS**  
**CMOS ANALOG-TO-DIGITAL CONVERTER**

SLAS243E – NOVEMBER 1999 – REVISED DECEMBER 2003

electrical characteristics over recommended operating conditions,  $AV_{DD} = 3\text{ V}$ ,  $DV_{DD} = 3\text{ V}$ ,  $f_s = 30\text{ MSPS}/50\%$  duty cycle,  $MODE = AV_{DD}$ , 2-V input span from 0.5 V to 2.5 V, external reference,  $T_A = T_{min}$  to  $T_{max}$  (unless otherwise noted) (continued)

**dc accuracy**

PARAMETER		MIN	TYP	MAX	UNIT
INL	Integral nonlinearity (see Note 2)		±1	±2	LSB
DNL	Differential nonlinearity (see Note 3)		±0.3	±1	LSB
	Offset error (see Note 4)		0.4	1.4	%FSR
	Gain error (see Note 5)		1.4	3.5	%FSR
	Missing code	No missing code assured			

- NOTES:
- Integral nonlinearity refers to the deviation of each individual code from a line drawn from zero to full scale. The point used as zero occurs 1/2 LSB before the first code transition. The full-scale point is defined as a level 1/2 LSB beyond the last code transition. The deviation is measured from the center of each particular code to the true straight line between these two endpoints.
  - An ideal ADC exhibits code transitions that are exactly 1 LSB apart. DNL is the deviation from this ideal value. Therefore this measure indicates how uniform the transfer function step sizes are. The ideal step size is defined here as the step size for the device under test (i.e., (last transition level – first transition level) ÷ (2<sup>n</sup> – 2)). Using this definition for DNL separates the effects of gain and offset error. A minimum DNL better than –1 LSB ensures no missing codes.
  - Offset error is defined as the difference in analog input voltage – between the ideal voltage and the actual voltage – that will switch the ADC output from code 0 to code 1. The ideal voltage level is determined by adding the voltage corresponding to 1/2 LSB to the bottom reference level. The voltage corresponding to 1 LSB is found from the difference of top and bottom references divided by the number of ADC output levels (1024).
  - Gain error is defined as the difference in analog input voltage – between the ideal voltage and the actual voltage – that will switch the ADC output from code 1022 to code 1023. The ideal voltage level is determined by subtracting the voltage corresponding to 1.5 LSB from the top reference level. The voltage corresponding to 1 LSB is found from the difference of top and bottom references divided by the number of ADC output levels (1024).

**dynamic performance (See Note 6)**

PARAMETER		TEST CONDITIONS	MIN	TYP	MAX	UNIT
ENOB	Effective number of bits	f = 3.5 MHz	8.4	9		Bits
		f = 3.5 MHz, $AV_{DD} = 5\text{ V}$		9		
		f = 15 MHz, 3 V		7.8		
		f = 15 MHz, $AV_{DD} = 5\text{ V}$		7.7		
SFDR	Spurious free dynamic range	f = 3.5 MHz	56	60.6		dB
		f = 3.5 MHz, $AV_{DD} = 5\text{ V}$		64.6		
		f = 15 MHz		48.5		
		f = 15 MHz, $AV_{DD} = 5\text{ V}$		53		
THD	Total harmonic distortion	f = 3.5 MHz		–60	–56	dB
		f = 3.5 MHz, $AV_{DD} = 5\text{ V}$		–66.9		
		f = 15 MHz		–47.5		
		f = 15 MHz, $AV_{DD} = 5\text{ V}$		–53.1		
SNR	Signal-to-noise ratio	f = 3.5 MHz	53	57		dB
		f = 3.5 MHz, $AV_{DD} = 5\text{ V}$		56		
		f = 15 MHz		53.1		
		f = 15 MHz, $AV_{DD} = 5\text{ V}$		49.4		
SINAD	Signal-to-noise and distortion	f = 3.5 MHz	52.5	56		dB
		f = 3.5 MHz, $AV_{DD} = 5\text{ V}$		56		
		f = 15 MHz		48.6		
		f = 15 MHz, $AV_{DD} = 5\text{ V}$		48.1		

- NOTES: 6. Input amplitude of single tone sine wave for dynamic tests is –0.5 dBFS.



**THS1030**  
**3-V TO 5.5-V, 10-BIT, 30 MSPS**  
**CMOS ANALOG-TO-DIGITAL CONVERTER**

SLAS243E – NOVEMBER 1999 – REVISED DECEMBER 2003

electrical characteristics over recommended operating conditions,  $AV_{DD} = 3\text{ V}$ ,  $DV_{DD} = 3\text{ V}$ ,  $f_s = 30\text{ MSPS}$ /50% duty cycle,  $MODE = AV_{DD}$ , 2-V input span from 0.5 V to 2.5 V, external reference,  $T_A = T_{min}$  to  $T_{max}$  (unless otherwise noted) (continued)

**clock**

PARAMETER		MIN	TYP	MAX	UNIT
$t_c$	Clock cycle	33			ns
$t_w(CKH)$	Pulse duration, clock high	15	16.5	110	ns
$t_w(CKL)$	Pulse duration, clock low	15	16.5	110	ns
$t_{d(o)}$	Clock to data valid, delay time			25	ns
$t_{d(DZ)}$	Output disable to Hi-Z output, disable time			20	ns
$t_{d(DEN)}$	Output enable to output valid, enable time			20	ns
	Pipeline latency		3		Cycles
$t_{d(AP)}$	Aperture delay time		4		ns
	Aperture uncertainty (jitter)		2		ps

**power supply (See Note 7)**

PARAMETER	TEST CONDITIONS	MIN	TYP	MAX	UNIT	
$I_{CC}$	Operating supply current	$AV_{DD} = DV_{DD} = 3\text{ V}$ , $MODE = AV_{DD}$		29	40	mA
$P_D$	Power dissipation	$AV_{DD} = DV_{DD} = 3\text{ V}$		87	120	mW
		$AV_{DD} = DV_{DD} = 5\text{ V}$		150		
$P_D(STBY)$	Standby power	$AV_{DD} = DV_{DD} = 3\text{ V}$ , $MODE = AV_{DD}$		3	5	mW

NOTES: 7. Mode and REFSENSE are set to  $AV_{DD}$ . The internal reference buffer is powered up to buffer the externally applied 0.5 V REFBS and 2.5 V REFTS. 1.5 VDC is applied at AIN while converting data at 30 MSPS.



**PARAMETER MEASUREMENT INFORMATION**

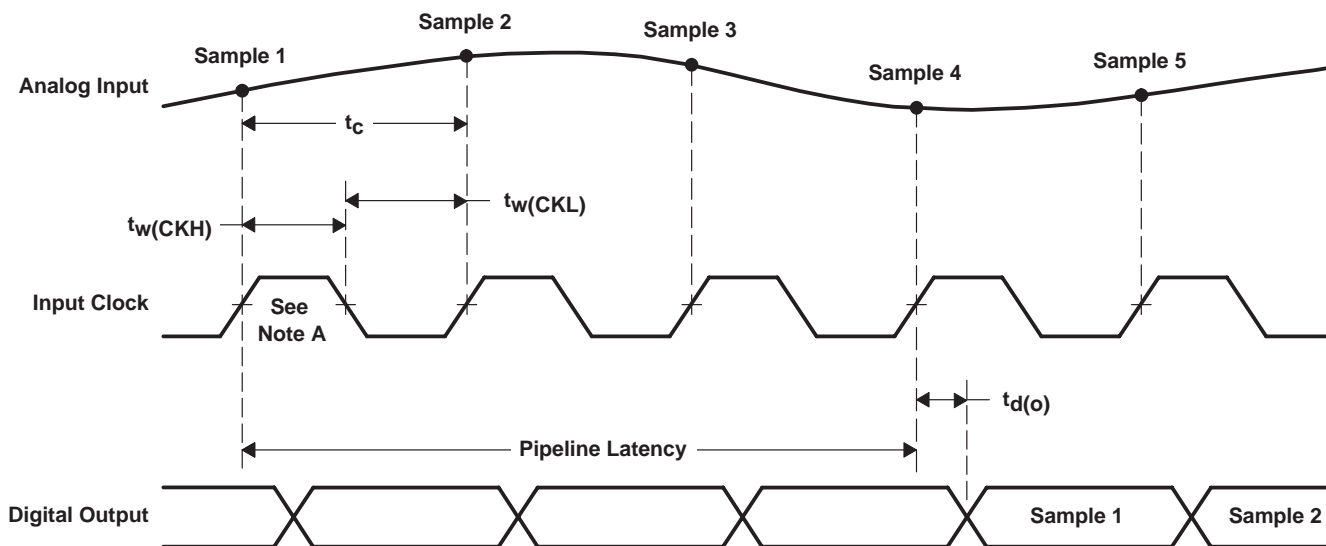

NOTE A: All timing measurements are based on 50% of edge transition.

**Figure 1. Digital Output Timing Diagram**

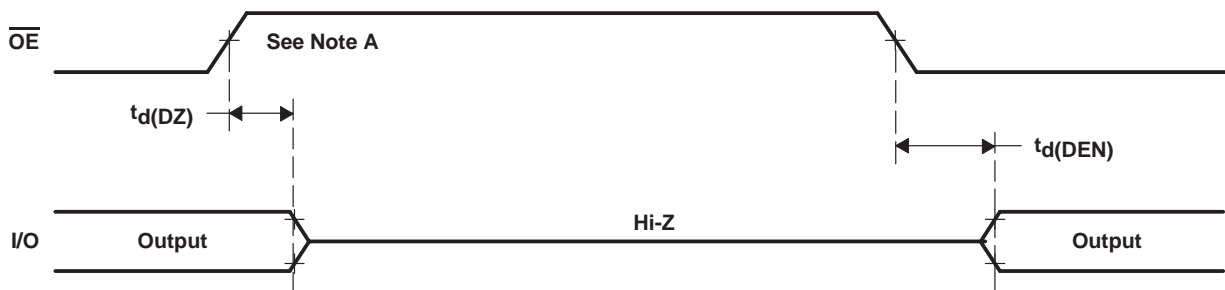

NOTE A: All timing measurements are based on 50% of edge transition.

**Figure 2. Output Enable Timing Diagram**

**THS1030**  
**3-V TO 5.5-V, 10-BIT, 30 MSPS**  
**CMOS ANALOG-TO-DIGITAL CONVERTER**

SLAS243E – NOVEMBER 1999 – REVISED DECEMBER 2003

**TYPICAL CHARACTERISTICS**

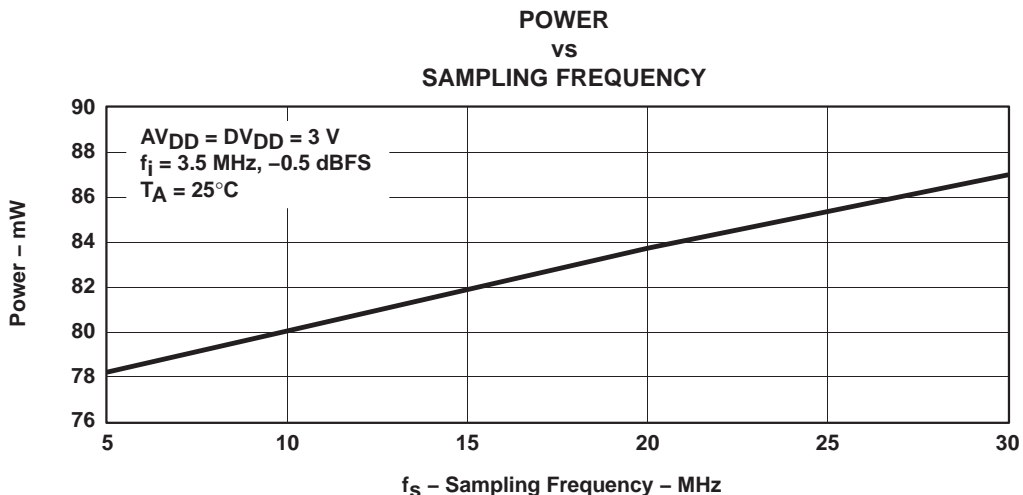

**Figure 3**

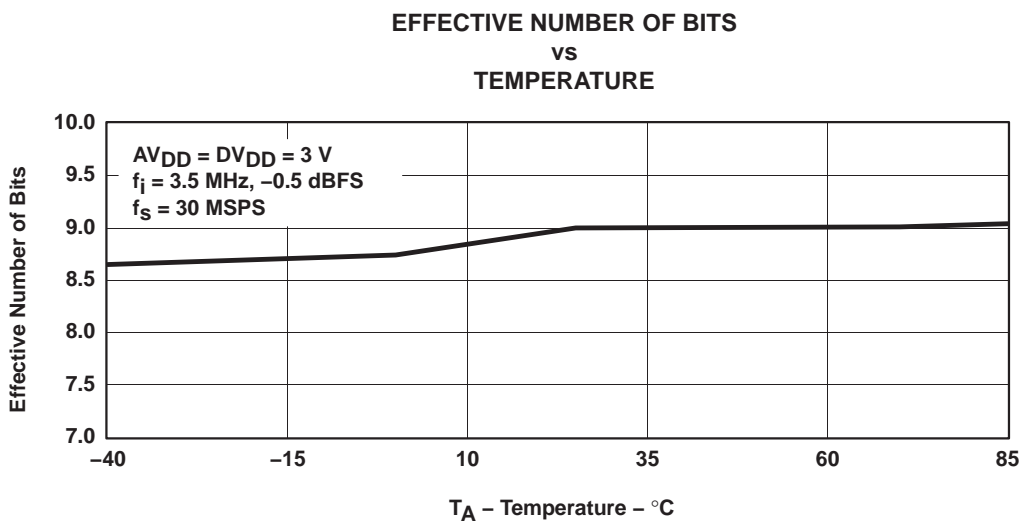

**Figure 4**

**TYPICAL CHARACTERISTICS**

**EFFECTIVE NUMBER OF BITS  
 vs  
 SAMPLING FREQUENCY**

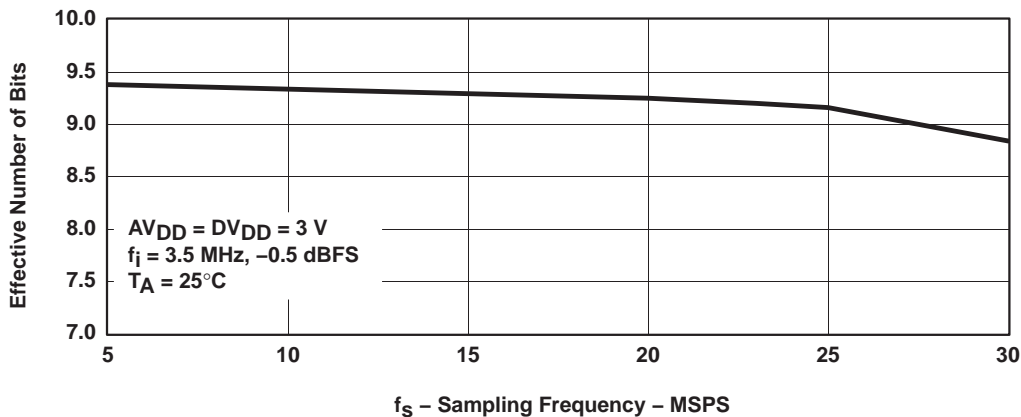

**Figure 5**

**EFFECTIVE NUMBER OF BITS  
 vs  
 SAMPLING FREQUENCY**

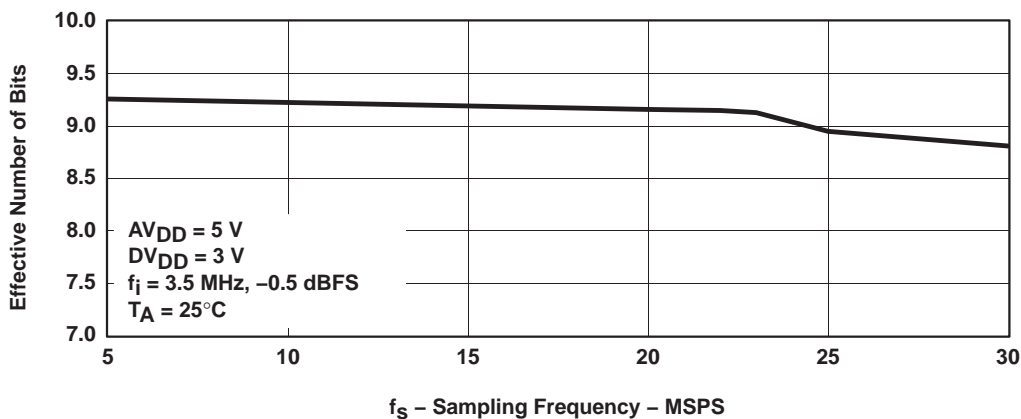

**Figure 6**

**THS1030**  
**3-V TO 5.5-V, 10-BIT, 30 MSPS**  
**CMOS ANALOG-TO-DIGITAL CONVERTER**

SLAS243E – NOVEMBER 1999 – REVISED DECEMBER 2003

**TYPICAL CHARACTERISTICS**

**EFFECTIVE NUMBER OF BITS**  
**vs**  
**SAMPLING FREQUENCY**

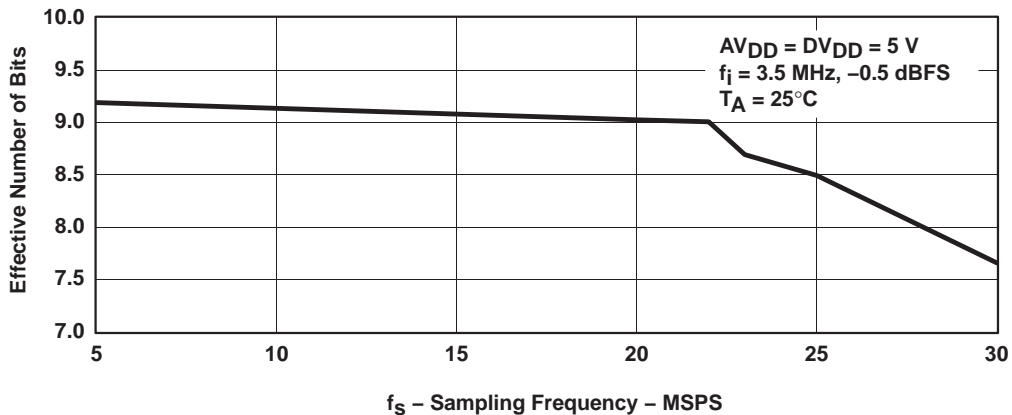

**Figure 7**

**DIFFERENTIAL NONLINEARITY**  
**vs**  
**INPUT CODE**

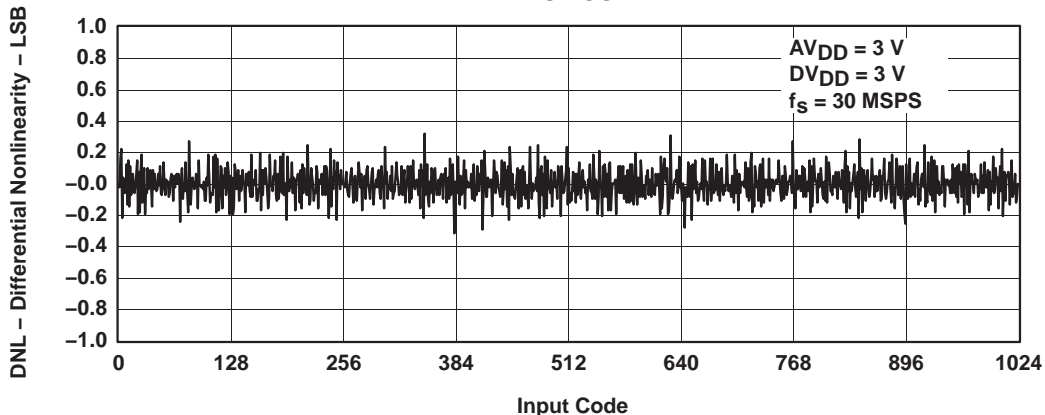

**Figure 8**

TYPICAL CHARACTERISTICS

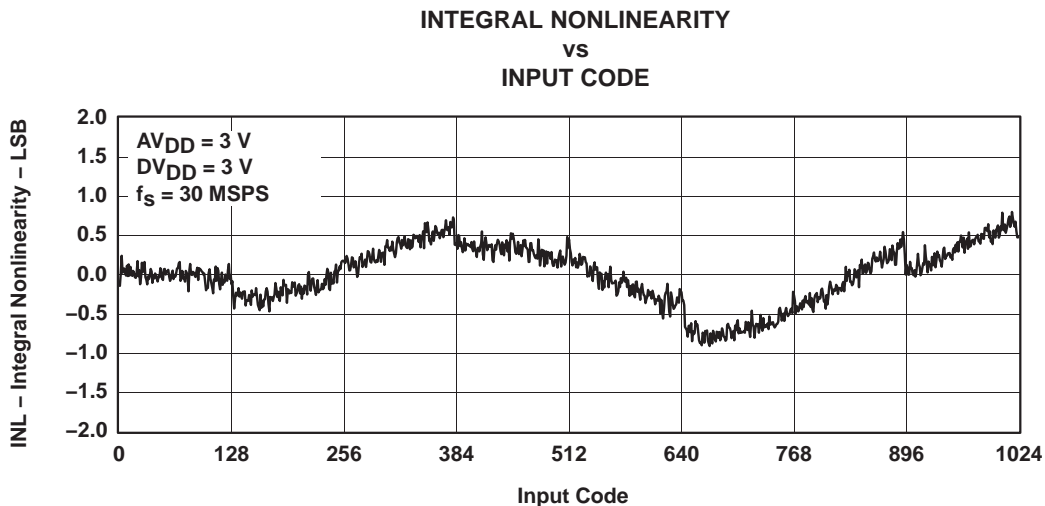

Figure 9

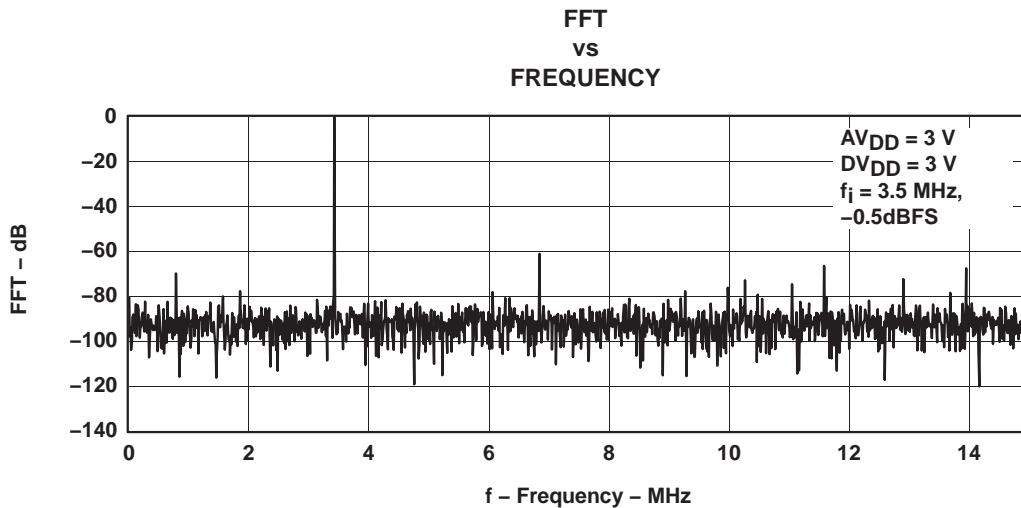

Figure 10

# THS1030

## 3-V TO 5.5-V, 10-BIT, 30 MSPS

### CMOS ANALOG-TO-DIGITAL CONVERTER

SLAS243E – NOVEMBER 1999 – REVISED DECEMBER 2003

#### PRINCIPLES OF OPERATION

The analog input AIN is sampled in the sample and hold unit, the output of which feeds the ADC core, where the process of analog to digital conversion is performed against ADC reference voltages, REFTF and REFBF.

Connecting the MODE pin to one of three voltages, AGND,  $AV_{DD}$  or  $AV_{DD}/2$  sets up operating configurations. The three settings open or close internal switches to select one of the three basic methods of ADC reference generation.

Depending on the user's choice of operating configuration, the ADC reference voltages may come from the internal reference buffer or may be fed from completely external sources. Where the reference buffer is employed, the user can choose to drive it from the onboard reference generator (ORG), or may use an external voltage source. A specific configuration is selected by connections to the REFSENSE, VREF, REFTS and REFBS, and REFTF and REFBF pins, along with any external voltage sources selected by the user.

The ADC core drives out through output buffers to the data pins D0 to D9. The output buffers can be disabled by the  $\overline{OE}$  pin.

A single, sample-rate clock (30 MHz maximum) is required at pin CLK. The analog input signal is sampled on the rising edge of CLK, and corresponding data is output after following third rising edge.

The STBY pin controls the THS1030 power down.

The user-chosen operating configuration and reference voltages determine what input signal voltage range the THS1030 can handle.

The following sections explain:

- The internal signal flow of the device, and how the input signal span is related to the ADC reference voltages
- The ways in which the ADC reference voltages can be buffered internally, or externally applied
- How to set the onboard reference generator output, if required, and several examples of complete configurations

#### signal processing chain (sample and hold, ADC)

Figure 11 shows the signal flow through the sample and hold unit to the ADC core.

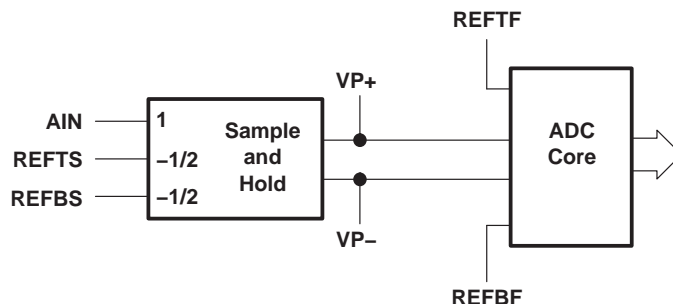

Figure 11. Analog Input Signal Flow

## PRINCIPLES OF OPERATION

### sample and hold

The analog input signal  $A_{IN}$  is applied to the AIN pin, either dc-coupled or ac-coupled.

The differential sample and hold processes  $A_{IN}$  with respect to the voltages applied to the REFTS and REFBS pins, to give a differential output  $VP^+ - VP^- = VP$  given by:

$$VP = A_{IN} - VM$$

Where:

$$VM = \frac{(REFTS + REFBS)}{2} \quad (1)$$

For single-ended input signals, VM is a constant voltage; usually the AIN mid-scale input voltage. However if  $MODE = AV_{DD}/2$  then REFTS and REFBS can be connected together to operate with AIN as a complementary pair of differential inputs (see Figures 16 and 17).

### analog-to-digital converter

In all operating configurations, VP is digitized against ADC reference voltages REFTF and REFBF, full-scale values of VP being given by:

$$VPFS^+ = \frac{+(REFTF - REFBF)}{2} \quad (2)$$

$$VPFS^- = \frac{-(REFTF - REFBF)}{2}$$

VP voltages outside the range  $VPFS^-$  to  $VPFS^+$  lie outside the conversion range of the ADC. Attempts to convert out-of-range inputs are signaled to the application by driving the OVR output pin high. VP voltages less than  $VPFS^-$  give ADC output code 0. VP voltages greater than  $VPFS^+$  give output code 1023.

### complete system

Combining the above equations, the analog full scale input voltages at AIN which give  $VPFS^+$  and  $VPFS^-$  at the sample and hold output are:

$$A_{IN} = FS^+ = VM + \frac{(REFTF - REFBF)}{2} \quad (3)$$

and

$$A_{IN} = FS^- = VM - \frac{(REFTF - REFBF)}{2} \quad (4)$$

The analog input span (voltage range) that lies within the ADC conversion range is:

$$\text{Input span} = [(FS^+) - (FS^-)] = (REFTF - REFBF) \quad (5)$$

The REFTF and REFBF voltage difference sets the device input range. The next sections describe in detail the various methods available for setting voltages REFTF and REFBF to obtain the desired input span and ADC performance.

**THS1030**  
**3-V TO 5.5-V, 10-BIT, 30 MSPS**  
**CMOS ANALOG-TO-DIGITAL CONVERTER**

SLAS243E – NOVEMBER 1999 – REVISED DECEMBER 2003

**PRINCIPLES OF OPERATION**

**ADC reference generation**

The THS1030 has three primary modes of ADC reference generation, selected by the voltage level applied to the MODE pin.

Connecting the MODE pin to AGND gives full external reference mode. In this mode, the user supplies the ADC reference voltages directly to pins REFTF and REFBF. This mode is used where there is need for minimum power drain or where there are very tight tolerances on the ADC reference voltages. This mode also offers the possibility of Kelvin connection of the reference inputs to the THS1030 to eliminate any voltage drops from remote references that may occur in the system. Only single-ended input is possible in this mode.

Connecting the MODE pin to  $AV_{DD}/2$  gives differential mode. In this mode, the ADC reference voltages REFTF and REFBF are generated by the internal reference buffer from the voltage applied to the VREF pin. This mode is suitable for handling differentially presented inputs, which are applied to the AIN and REFTS/REFBS pins. A special case of differential mode is center span mode, in which the user applies a single-ended signal to AIN and applies the mid-scale input voltage (VM) to the REFTS and REFBS pins.

Connecting the MODE pin to  $AV_{DD}$  gives top/bottom mode. In this mode, the ADC reference voltages REFTF and REFBF are generated by the internal reference buffer from the voltages applied to the REFTS and REFBS pins. Only single-ended input is possible in top/bottom mode.

When MODE is connected to AGND, the internal reference buffer is powered down, its inputs and outputs disconnected, and REFTS and REFBS internally connected to REFTF and REFBF respectively. These nodes are connected by the user to external sources to provide the ADC reference voltages. The internal connections are designed for use in kelvin connection mode (Figure 14). When using external reference mode as shown in Figure 13, REFTS must be shorted to REFTF and REFBS must be shorted to REFBF externally. The mean of REFTF and REFBF must be equal to  $AV_{DD}/2$ . See Figure 13.

**Table 1. Typical Set of Reference Connections**

REFERENCE MODE	MODE	REFSENSE	VREF VOLTAGE	REFTS, REFBS	ANALOG INPUT	FIGURES
External	AGND	$AV_{DD}$	Disabled	Reference buffer powered down, reference voltage provided directly by REFT and REFB	Single-ended	12, 13, 14
Internal	$AV_{DD}/2$	VREF	1 V	Externally connect REFTS to REFBS. This pair then forms AIN– to the ADC.	Differential or center span	15, 16, 17
		AGND	2 V			
		External divider	$1 + R_a/R_b$ (see Figure 22)			
External (through internal reference buffer)	$AV_{DD}$	$AV_{DD}$	Disabled	$REFTS = V_{FS+}$ $REFBS = V_{FS-}$	Single-ended (top-bottom mode)	18, 19
Output of VREF can be externally tied to REFTS or REFBS to provide one of the reference voltages		VREF	1 V			
		AGND	2 V			
		External divider	$1 + R_a/R_b$ (see Figure 22)			



**PRINCIPLES OF OPERATION**

full external reference mode (mode = AGND)

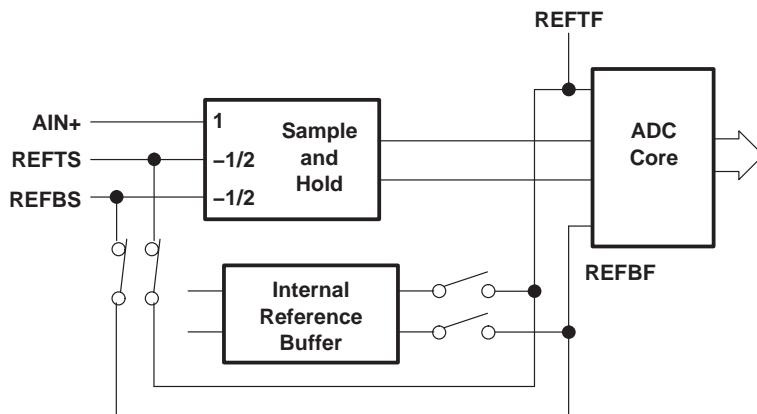

**Figure 12. ADC Reference Generation, Full External Reference Mode (MODE = AGND)**

It is also possible to use REFTS and REFBS as sense lines to drive the REFTF and REFBF lines (Kelvin mode) to overcome any voltage drops within the system. See Figure 14.

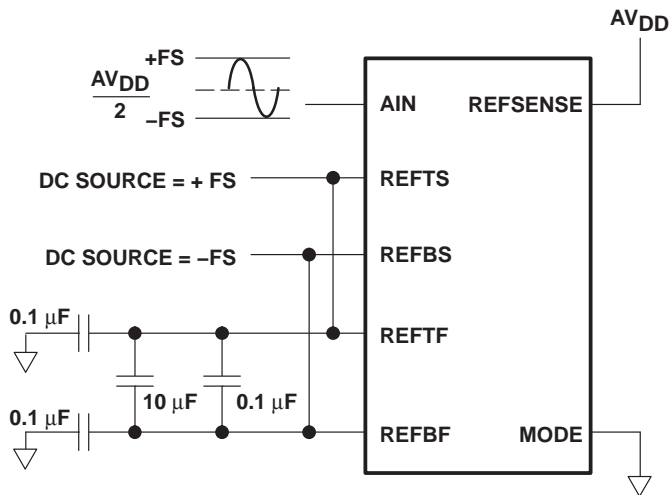

**Figure 13. Full External Reference Mode**

**PRINCIPLES OF OPERATION**

**full external reference mode (mode = AGND) (continued)**

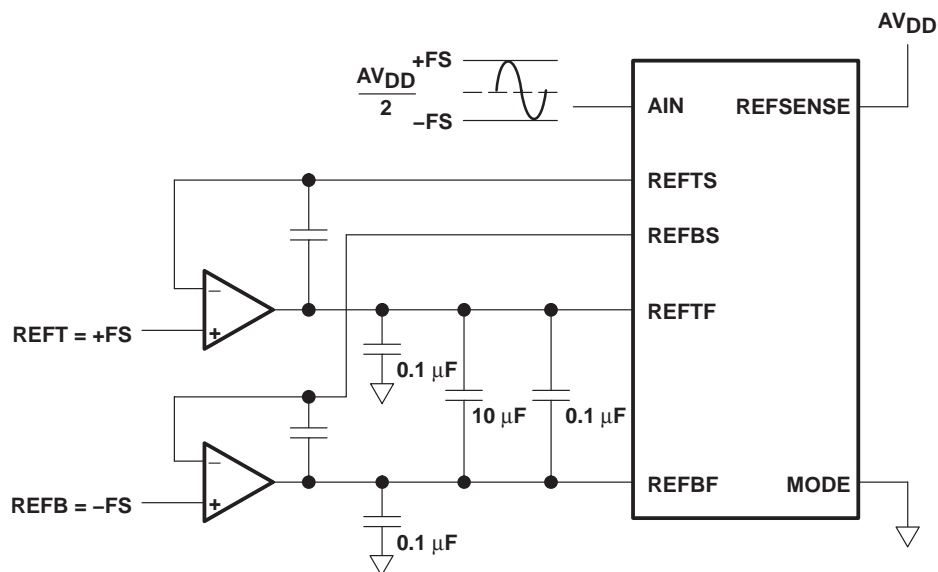

**Figure 14. Full External Reference With Kelvin Connections**

**differential input mode (MODE = AV<sub>DD</sub>/2)**

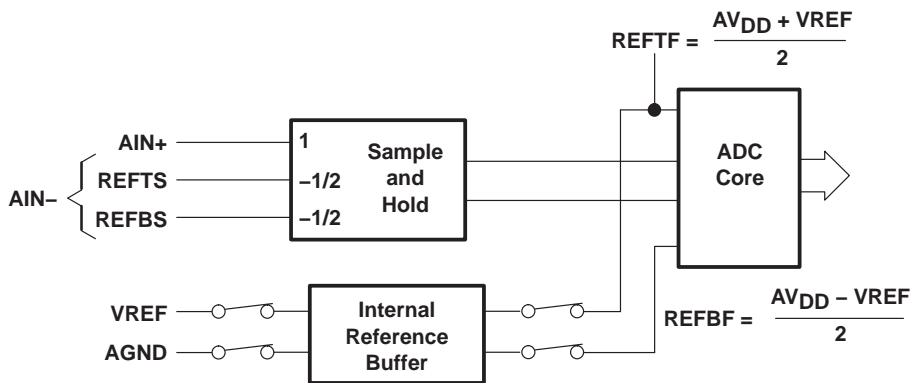

**Figure 15. ADC Reference Generation, MODE = AV<sub>DD</sub>/2**

When MODE = AV<sub>DD</sub>/2, the internal reference buffer is enabled, its outputs internally switched to REFTF and REFBS and inputs internally switched to VREF and AGND as shown in Figure 15. The REFTF and REFBS voltages are centered on AV<sub>DD</sub>/2 by the internal reference buffer and the voltage difference between REFTF and REFBS equals the voltage at VREF. The internal REFTS to REFBS and REFTF to REFBS switches are open in this mode, allowing REFTS and REFBS to form the AIN<sup>-</sup> to the sample and hold.

Depending on the connection of the REFSense pin, the voltage on VREF may be externally driven, or set to an internally generated voltage of 1 V, 2 V, or an intermediate voltage (see the section on onboard reference generator configuration).

**PRINCIPLES OF OPERATION**

**differential input mode (MODE =  $AV_{DD}/2$ ) (continued)**

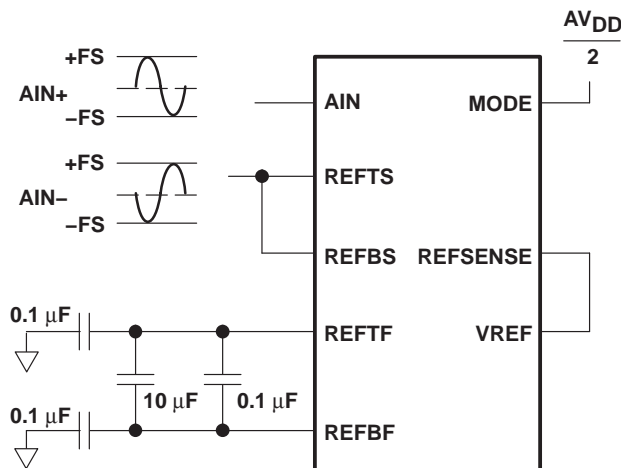

**Figure 16. Differential Input Mode, 1-V Reference Span**

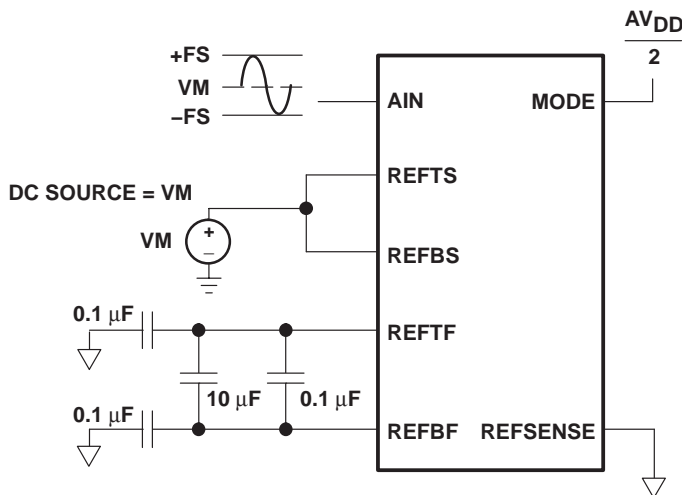

**Figure 17. Center Span Mode, 2-V Reference Span**

**THS1030**  
**3-V TO 5.5-V, 10-BIT, 30 MSPS**  
**CMOS ANALOG-TO-DIGITAL CONVERTER**

SLAS243E – NOVEMBER 1999 – REVISED DECEMBER 2003

**PRINCIPLES OF OPERATION**

top/bottom mode (MODE = AV<sub>DD</sub>)

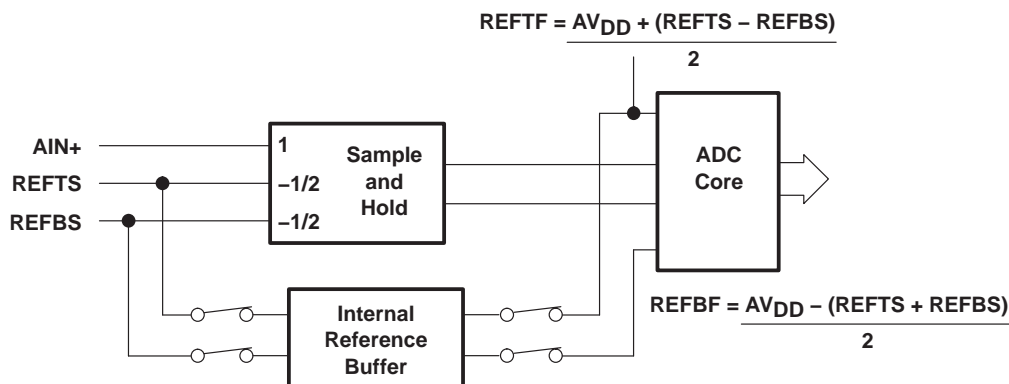
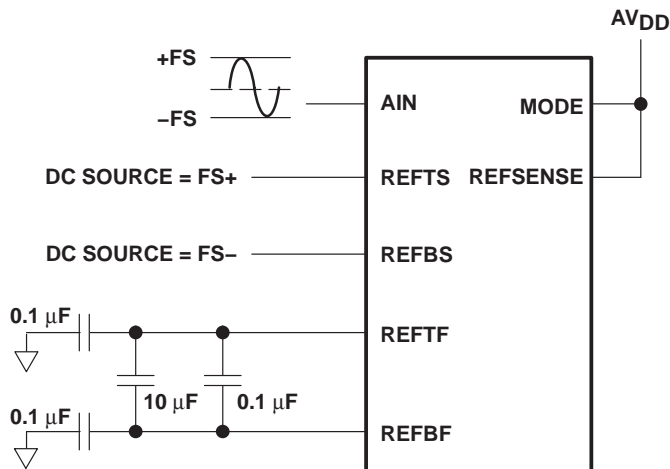

**Figure 18. ADC Reference Generation Mode = AV<sub>DD</sub>**

Connecting MODE to AV<sub>DD</sub> enables the internal reference buffer. Its inputs are internally switched to the REFTS and REFBS pins and its outputs internally switched to pins REFTF and REFBF. The internal connections (REFTS to REFTF) and (REFBS to REFBF) are broken.

The REFTS and REFBS voltages set the analog input span limits FS+ and FS- respectively. Any voltages at AIN greater than REFTS or less than REFBS will cause ADC over-range, which is signaled by OVR going high when the conversion result is output.

Typically, REFSENSE is tied to AV<sub>DD</sub> to disable the ORG output to VREF (as in Figure 19), but the user can choose to use the ORG output to VREF as either REFTS or REFBS.



**Figure 19. Top/Bottom Reference Mode**

## PRINCIPLES OF OPERATION

### onboard reference generator configuration

The onboard reference generator (ORG) can provide a supply-voltage-independent and temperature-independent voltage on pin VREF.

External connections to REFSENSE control the ORG's output to the VREF pin as shown in Table 2.

**Table 2. Effect of REFSENSE Connection on VREF Value**

REFSENSE CONNECTION	ORG OUTPUT TO VREF	REFER TO:
VREF pin	1 V	Figure 20
AGND	2 V	Figure 21
External divider junction	$(1 + R_A/R_B)$	Figure 22
AVDD	Open circuit	Figure 23

REFSENSE = AV<sub>DD</sub> powers the ORG down, saving power when the ORG function is not required.

If MODE = AV<sub>DD</sub>/2, the voltage on VREF determines the ADC reference voltages:

$$\text{REFTF} = \frac{\text{AV}_{\text{DD}}}{2} + \frac{\text{VREF}}{2} \tag{6}$$

$$\text{REFBF} = \frac{\text{AV}_{\text{DD}}}{2} - \frac{\text{VREF}}{2}$$

$$\text{REFTF} - \text{REFBF} = \text{VREF}$$

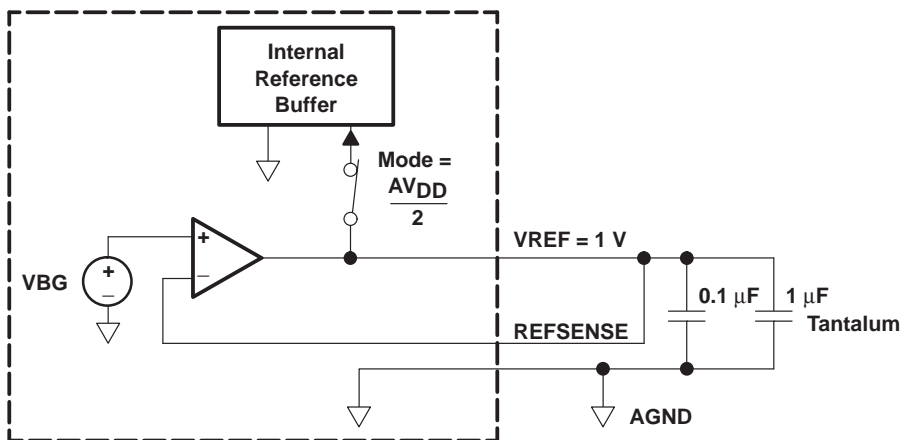

**Figure 20. 1-V VREF Using ORG**

**PRINCIPLES OF OPERATION**

**onboard reference generator configuration (continued)**

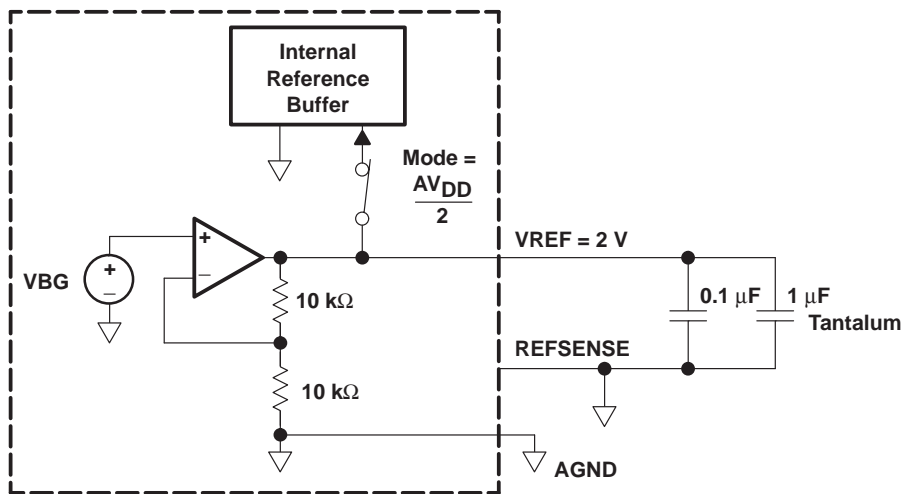

**Figure 21. 2-V VREF Using ORG**

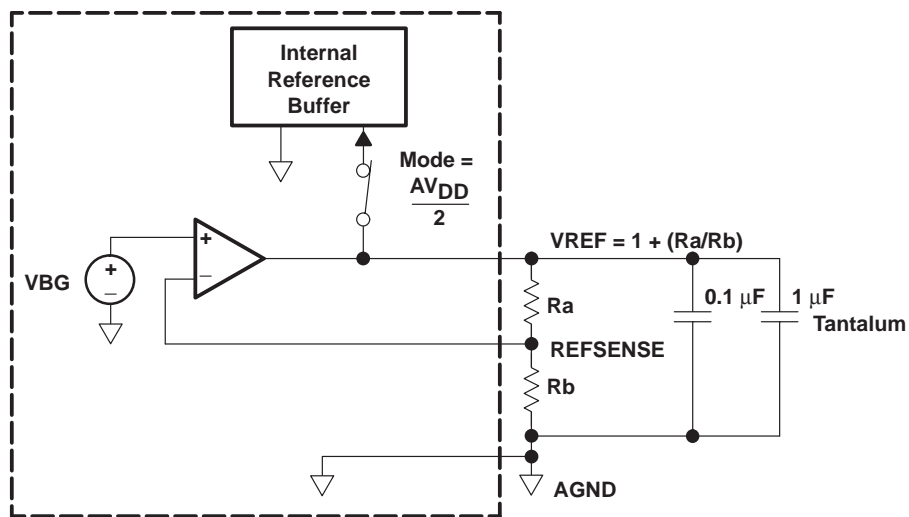

**Figure 22. External Divider Mode**

**PRINCIPLES OF OPERATION**

**onboard reference generator configuration (continued)**

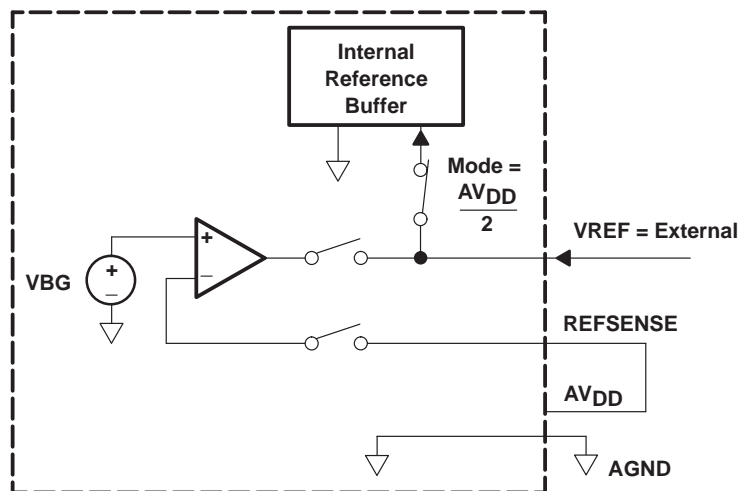
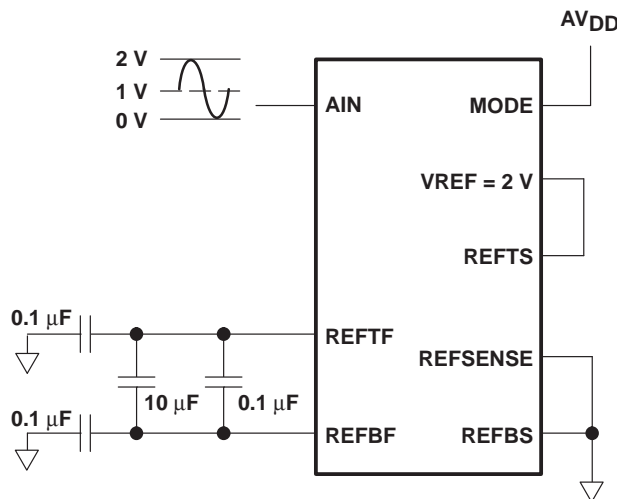

**Figure 23. Drive VREF Mode**

**operating configuration examples**

This section provides examples of operating configurations.

Figure 24 shows the operating configuration in top/bottom mode for a 2-V span single-ended input, using VREF to drive REFTS. Connecting the mode pin to  $AV_{DD}$  puts the THS1030 in top/bottom mode. Connecting pin REFSENSE to AGND sets the output of the ORG to 2 V. REFTS and REFBS are user-connected to VREF and AGND respectively to match the AIN pin input range to the voltage range of the input signal.



**Figure 24. Operation Configuration in Top/Bottom Mode**

In Figure 25 the input signal is differential, so mode =  $AV_{DD}/2$  (differential mode) is set to allow the inverse signal to be applied to REFTS and REFBS. The differential input goes from  $-0.8$  V to  $0.8$  V, giving a total input signal span of 1.6 V, REFTF–REFBF should therefore equal 1.6 V. REFSENSE is connected to resistors  $R_A$  and  $R_B$  (external divider mode) to make  $V_{REF} = 1.6$  V, that is  $R_A/R_B = 0.6$  (see Figure 22).

**THS1030**  
**3-V TO 5.5-V, 10-BIT, 30 MSPS**  
**CMOS ANALOG-TO-DIGITAL CONVERTER**

SLAS243E – NOVEMBER 1999 – REVISED DECEMBER 2003

**PRINCIPLES OF OPERATION**

**operating configuration examples (continued)**

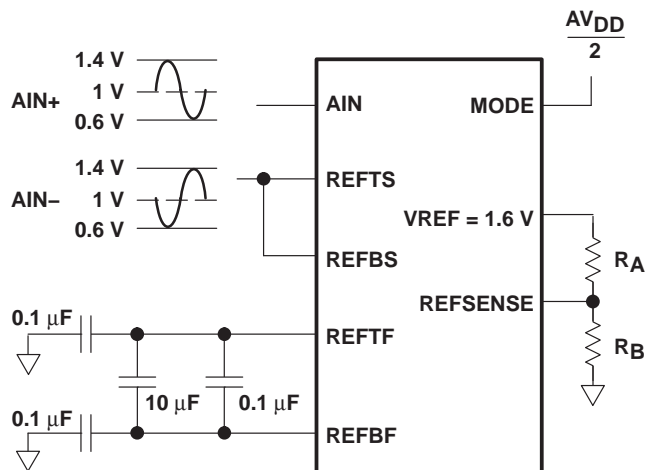

**Figure 25. Differential Operation**

Figure 26 shows a center span configuration for an input waveform swinging between 0.2 V and 1.9 V. Pins REFTS and REFBS are connected to a voltage source of 1.05 V, equal to the mid-scale of the input waveform. REFTF–REFBF should be set equal to the span of the input waveform, 1.7 V, so VREF is connected to an external source of 1.7 V. REFSENSE must be connected to  $AV_{DD}$  to disable the ORG output to VREF (see Figure 23) to allow this external source to be applied.

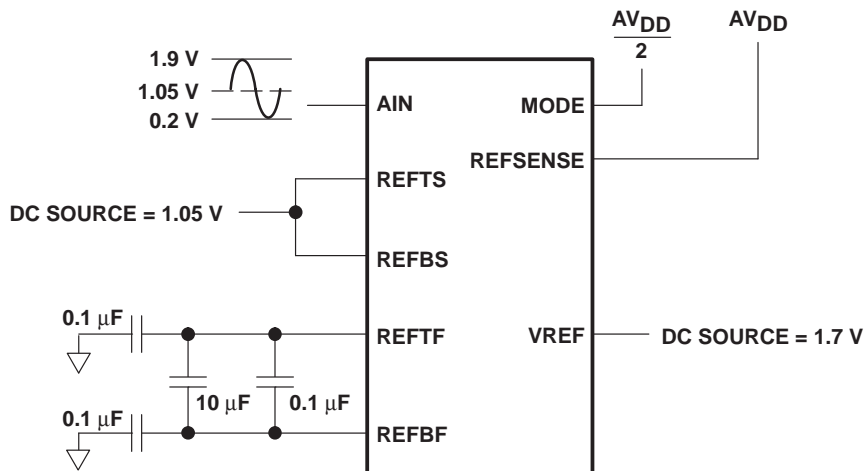

**Figure 26. Center Span Operation**

## PRINCIPLES OF OPERATION

### power management

In power-sensitive applications (such as battery-powered systems) where the THS1030 ADC is not required to convert continuously, power can be saved between conversion intervals by placing the THS1030 into power-down mode. This is achieved by setting pin 17 (STBY) to 1. In power-down mode, the device typically consumes less than 1 mW of power (from  $AV_{DD}$  and  $DV_{DD}$ ) in either top/bottom mode or center-span mode. On power up, the THS1030 typically requires 5 ms of wake-up time before valid conversion results are available in either top/bottom or center span modes.

Disabling the ORG in applications where the ORG output is not required can also reduce power dissipation by 1 mA analog  $I_{DD}$ . This is achieved by connecting the REFSENSE pin to  $AV_{DD}$ .

### output format and digital I/O

While the  $\overline{OE}$  pin is held low, ADC conversion results are output at pins D0 (LSB) to D9 (MSB). The ADC input over-range indicator is output at pin OVR. OVR is also disabled when  $\overline{OE}$  is held high.

The ADC output data format is unsigned binary (output codes 0 to 1023).

### driving the THS1030 analog inputs

#### driving AIN

Figure 26 shows an equivalent circuit for the THS1030 AIN pin. The load presented to the system at the AIN pin comprises the switched input sampling capacitor,  $C_{SAMPLE}$ , and various stray capacitances,  $C_{P1}$  and  $C_{P2}$ .

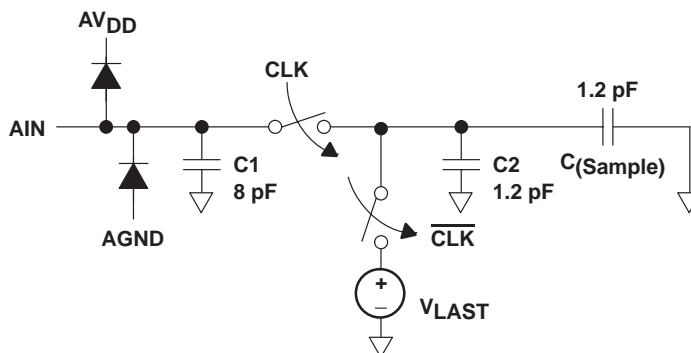

**Figure 27. Equivalent Circuit of Analog Input AIN**

In any single-ended input mode,  $V_{LAST}$  = the average of the previously sampled voltage at AIN and the average of the voltages on pins REFTS and REFBS. In any differential mode,  $V_{LAST}$  = the common mode input voltage.

The external source driving AIN must be able to charge and settle into  $C_{SAMPLE}$  and the  $C_{P1}$  and  $C_{P2}$  strays to within 0.5 LSB error while sampling (CLK pin low) to achieve full ADC resolution.

**THS1030**  
**3-V TO 5.5-V, 10-BIT, 30 MSPS**  
**CMOS ANALOG-TO-DIGITAL CONVERTER**

SLAS243E – NOVEMBER 1999 – REVISED DECEMBER 2003

**PRINCIPLES OF OPERATION**

**AIN input current and input load modeling**

When CLK goes low, the source driving AIN must charge the total switched capacitance  $C_S = C_{SAMPLE} + C_{P2}$ . The total charge transferred depends on the voltage at AIN and is given by:

$$Q_{CHARGING} = (A_{IN} - V_{LAST}) \times C_S \tag{7}$$

For a fixed voltage at AIN, so that AIN and  $V_{LAST}$  do not change between samples, the maximum amount of charge transfer occurs at  $A_{IN} = FS-$  (charging current flows out of THS1030) and  $A_{IN} = FS+$  (current flows into THS1030). If AIN is held at the voltage  $FS+$ ,  $V_{LAST} = [(FS+) + VM]/2$ , giving a maximum transferred charge:

$$Q(FS) = \frac{(FS+) - [(FS+) + VM]}{2} \times C_S = \frac{[(FS+) - VM] \times C_S}{2} \tag{8}$$

$$= (1/4 \text{ of the input voltage span}) \times C_S$$

If the input voltage changes between samples, then the maximum possible charge transfer is

$$Q(max) = 3 \times Q(FS) \tag{9}$$

which occurs for a full-scale input change ( $FS+$  to  $FS-$  or  $FS-$  to  $FS+$ ) between samples.

The charging current pulses can make the AIN source jump or ring, especially if the source is slightly inductive at high frequencies. Inserting a small series resistor of  $20 \Omega$  or less in the input path can damp source ringing (see Figure 31). This resistor can be made larger than  $20 \Omega$  if reduced input bandwidth or distortion performance is acceptable.

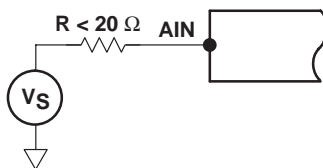
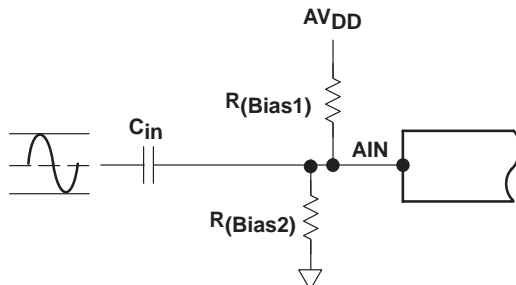

**Figure 28. Damping Source Ringing Using a Small Resistor**

## PRINCIPLES OF OPERATION

### equivalent input resistance at AIN and ac-coupling to AIN

Some applications may require ac-coupling of the input signal to the AIN pin. Such applications can use an ac-coupling network such as shown in Figure 29.



**Figure 29. AC-Coupling the Input Signal to the AIN Pin**

Note that if the bias voltage is derived from the supplies, as shown in Figure 29, then additional filtering should be used to ensure that noise from the supplies does not reach AIN.

Working with the input current pulse equations given in the previous section is awkward when designing ac-coupling input networks. For such design, it is much simpler to model the AIN input as an equivalent resistance,  $R_{AIN}$ , from the AIN pin to a voltage source  $V_M$  where

$$V_M = (REFTS + REFBS)/2 \text{ and } R_{AIN} = 1 / (C_S \times f_{clk})$$

where  $f_{clk}$  is the CLK frequency.

The high-pass –3 dB cutoff frequency for the circuit shown in Figure 29 is:

$$f_{(-3 \text{ dB})} = \frac{1}{(2 \times \pi \times R_{INtot})} \tag{10}$$

where  $R_{INtot}$  is the parallel combination of  $R_{bias1}$ ,  $R_{bias2}$ , and  $R_{AIN}$ . This approximation is good provided that the clock frequency,  $f_{clk}$ , is much higher than  $f_{(-3 \text{ dB})}$ .

Note also that the effect of the equivalent  $R_{AIN}$  and  $V_M$  at the AIN pin must be allowed for when designing the bias network dc level.

### details

The above value for  $R_{AIN}$  is derived by noting that the average AIN voltage must equal the bias voltage supplied by the ac coupling network. The average value of  $V_{LAST}$  in equation 8 is thus a constant voltage

$$V_{LAST} = V(\text{AIN bias}) - V_M$$

For an input voltage  $V_{in}$  at the AIN pin,

$$Q_{in} = (V_{in} - V_{LAST}) \times C_S$$

Provided that  $f_{(-3 \text{ dB})}$  is much lower than  $f_{clk}$ , a constant current flowing over the clock period can approximate the input charging pulse

$$\begin{aligned} I_{in} &= Q_{in} / t_{clk} \\ &= Q_{in} \times f_{clk} \\ &= (V_{in} - V_{LAST}) \times C_S \times f_{clk} \end{aligned}$$

**THS1030**  
**3-V TO 5.5-V, 10-BIT, 30 MSPS**  
**CMOS ANALOG-TO-DIGITAL CONVERTER**

SLAS243E – NOVEMBER 1999 – REVISED DECEMBER 2003

**PRINCIPLES OF OPERATION**

**details (continued)**

The ac input resistance  $R_{AIN}$  is then

$$\begin{aligned} R_{AIN} &= dI_{IN} / dV_{IN} \\ &= 1 / (dV_{IN} / dI_{IN}) \\ &= 1 / (C_S \times f_{CLK}) \end{aligned}$$

**driving the VREF pin (differential mode)**

Figure 30 shows the equivalent load on the VREF pin when driving the internal reference buffer via this pin (MODE =  $AV_{DD}/2$  and REFSENSE =  $AV_{DD}$ ).

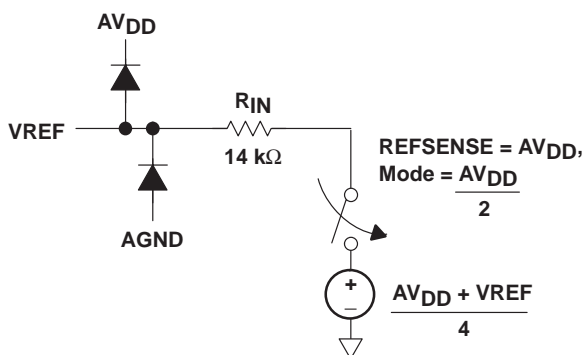

**Figure 30. Equivalent Circuit of VREF**

The current flowing into  $I_{IN}$  is given by

$$I_{IN} = \frac{(3 \times VREF - AV_{DD})}{(4 \times R_{IN})} \tag{11}$$

Note that the actual  $I_{IN}$  may differ from this value by up to  $\pm 50\%$  due to device-to-device processing variations and allowing for operating temperature variations.

The user should ensure that VREF is driven from a low noise, low drift source, well-decoupled to analog ground and capable of driving  $I_{IN}$ .

## PRINCIPLES OF OPERATION

### driving the internal reference buffer (top/bottom mode)

Figure 31 shows the load present on the REFTS and REFBS pins in top/bottom mode due to the internal reference buffer only. The sample and hold must also be driven via these pins, which adds additional load.

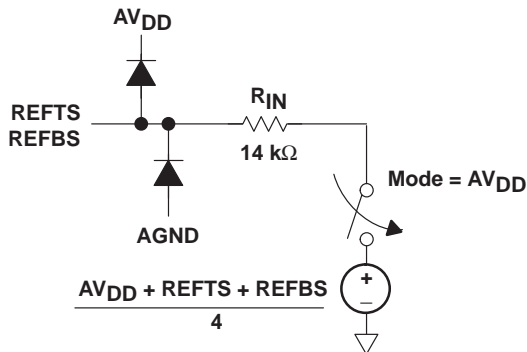

**Figure 31. Equivalent Circuit of Inputs to Internal Reference Buffer**

Equations for the currents flowing into REFTS and REFBS are:

$$I_{IN}^{TS} = \frac{(3 \times REFTS - AV_{DD} - REFBS)}{(4 \times R_{IN})} \quad (12)$$

$$I_{IN}^{BS} = \frac{(3 \times REFBS - AV_{DD} - REFTS)}{(4 \times R_{IN})} \quad (13)$$

These currents must be provided by the sources on REFTS and REFBS in addition to the requirements of driving the sample and hold. Tolerance on these currents are  $\pm 50\%$ .

### driving REFTS and REFBS

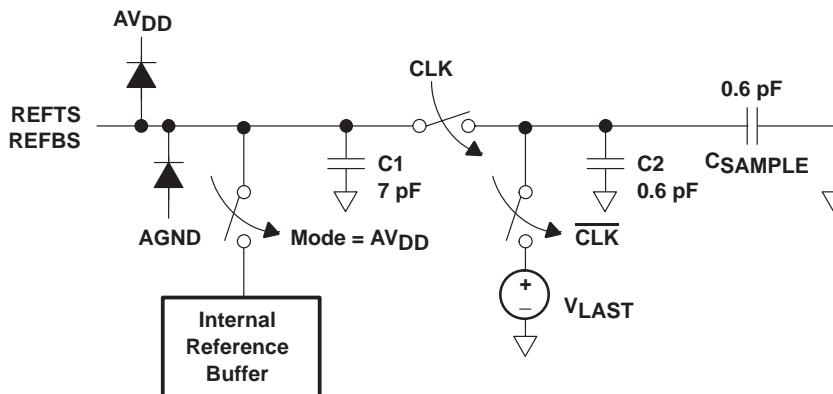

**Figure 32. Equivalent Circuit of REFTS and REFBS Inputs**

This is essentially a combination of driving the ADC internal reference buffer (if in top/bottom mode) and also driving a switched capacitor load like AIN, but with the sampling capacitor and  $C_{P2}$  on each pin now being 0.6 pF and about 0.6 pF respectively.

# THS1030

## 3-V TO 5.5-V, 10-BIT, 30 MSPS

### CMOS ANALOG-TO-DIGITAL CONVERTER

SLAS243E – NOVEMBER 1999 – REVISED DECEMBER 2003

#### PRINCIPLES OF OPERATION

##### driving REFTF and REFBF (full external reference mode)

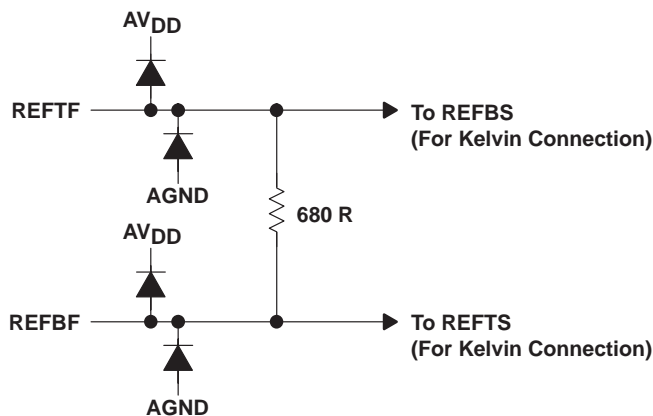

Figure 33. Equivalent Circuit of REFTF and REFBF Inputs

Note the need for off-chip decoupling.

##### driving the clock input

Obtaining good performance from the THS1030 requires care when driving the clock input.

Different sections of the sample-and-hold and ADC operate while the clock is low or high. The user should ensure that the clock duty cycle remains near 50% to ensure that all internal circuits have as much time as possible in which to operate.

The CLK pin should be driven from a low jitter source for best dynamic performance. To maintain low jitter at the CLK input, any clock buffers external to the THS1030 should have fast rising edges. Use a fast logic family such as AC or ACT to drive the CLK pin, and consider powering any clock buffers separately from any other logic on the PCB to prevent digital supply noise appearing on the buffered clock edges as jitter.

The CLK input threshold is nominally around  $AV_{DD}/2$ —ensure that any clock buffers have an appropriate supply voltage to drive above and below this level.

##### digital output loading and circuit board layout

The THS1030 outputs are capable of driving rail-to-rail with up to 20 pF of load per pin at 30-MHz clock and 3-V digital supply. Minimizing the load on the outputs will improve THS1030 signal-to-noise performance by reducing the switching noise coupling from the THS1030 output buffers to the internal analog circuits. The output load capacitance can be minimized by buffering the THS1030 digital outputs with a low input capacitance buffer placed as close to the output pins as physically possible, and by using the shortest possible tracks between the THS1030 and this buffer.

Noise levels at the output buffers, and hence coupling to the analog circuits within THS1030, becomes worse as the THS1030 digital supply voltage is increased. Where possible, consider using the lowest  $DV_{DD}$  that the application can tolerate.

Use good layout practices when designing the application PCB to ensure that any off-chip return currents from the THS1030 digital outputs (and any other digital circuits on the PCB) do not return via the supplies to any sensitive analog circuits. The THS1030 should be soldered directly to the PCB for best performance. Socketing the device will degrade performance by adding parasitic socket inductance and capacitance to all pins.



## PRINCIPLES OF OPERATION

### user tips for obtaining best performance from the THS1030

- Voltages on AIN, REFTF and REFBF and REFTS and REFBS must all be inside the supply rails.
- ORG modes offer the simplest configurations for ADC reference generation.
- Choose differential input mode for best distortion performance.
- Choose a 2-V ADC input span for best noise performance.
- Choose a 1-V ADC input span for best distortion performance.
- If the ORG is not used to provide ADC reference voltages, its output may be used for other purposes in the system. Care should be taken to ensure noise is not injected into the THS1030.
- Use external voltage sources for ADC reference generation where there are stringent requirements on accuracy and drift.
- Drive clock input CLK from a low-jitter, fast logic stage, with a well-decoupled power supply and short PCB traces.

### TLC876 mode

The THS1030 is pin compatible with the TI TLC876 and thus enables users of TLC876 to upgrade to higher speed by dropping the THS1030 into their sockets. Grounding the 1876M pin effectively puts the THS1030 into 876 mode using the external ADC reference. The MODE pin should either be grounded or left floating.

The REFSENSE pin is connected to  $DV_{DD}$  when the THS1030 is dropped into a TLC876 socket. For  $DV_{DD} = 5\text{-V}$  applications, this will disable the ORG. For TLC876 applications using  $DV_{DD} = 3.3\text{ V}$ , the VREF pin will be driven to  $AV_{SS}$ . In TLC876/AD876 mode, the pipeline latency is increased to 3.5 clock cycles to match the TLC876 latency.

**PACKAGING INFORMATION**

Orderable Device	Status (1)	Package Type	Package Drawing	Pins	Package Qty	Eco Plan (2)	Lead/Ball Finish (6)	MSL Peak Temp (3)	Op Temp (°C)	Device Marking (4/5)	Samples
THS1030CDW	OBSOLETE	SOIC	DW	28		TBD	Call TI	Call TI	0 to 70	TH1030	
THS1030CDWG4	OBSOLETE	SOIC	DW	28		TBD	Call TI	Call TI	0 to 70	TH1030	
THS1030CDWR	OBSOLETE	SOIC	DW	28		TBD	Call TI	Call TI	0 to 70	TH1030	
THS1030CPW	ACTIVE	TSSOP	PW	28	50	Green (RoHS & no Sb/Br)	CU NIPDAU	Level-1-260C-UNLIM	0 to 70	TH1030	<a href="#">Samples</a>
THS1030CPWR	ACTIVE	TSSOP	PW	28	2000	Green (RoHS & no Sb/Br)	CU NIPDAU	Level-1-260C-UNLIM	0 to 70	TH1030	<a href="#">Samples</a>
THS1030CPWRG4	ACTIVE	TSSOP	PW	28	2000	Green (RoHS & no Sb/Br)	CU NIPDAU	Level-1-260C-UNLIM	0 to 70	TH1030	<a href="#">Samples</a>
THS1030IDW	OBSOLETE	SOIC	DW	28		TBD	Call TI	Call TI	-40 to 85	TJ1030	
THS1030IPW	ACTIVE	TSSOP	PW	28	50	Green (RoHS & no Sb/Br)	CU NIPDAU	Level-1-260C-UNLIM	-40 to 85	TJ1030	<a href="#">Samples</a>
THS1030IPWG4	ACTIVE	TSSOP	PW	28	50	Green (RoHS & no Sb/Br)	CU NIPDAU	Level-1-260C-UNLIM	-40 to 85	TJ1030	<a href="#">Samples</a>
THS1030IPWR	ACTIVE	TSSOP	PW	28	2000	Green (RoHS & no Sb/Br)	CU NIPDAU	Level-1-260C-UNLIM	-40 to 85	TJ1030	<a href="#">Samples</a>
THS1030IPWRG4	ACTIVE	TSSOP	PW	28	2000	Green (RoHS & no Sb/Br)	CU NIPDAU	Level-1-260C-UNLIM	-40 to 85	TJ1030	<a href="#">Samples</a>

(1) The marketing status values are defined as follows:

**ACTIVE:** Product device recommended for new designs.

**LIFEBUY:** TI has announced that the device will be discontinued, and a lifetime-buy period is in effect.

**NRND:** Not recommended for new designs. Device is in production to support existing customers, but TI does not recommend using this part in a new design.

**PREVIEW:** Device has been announced but is not in production. Samples may or may not be available.

**OBSOLETE:** TI has discontinued the production of the device.

(2) Eco Plan - The planned eco-friendly classification: Pb-Free (RoHS), Pb-Free (RoHS Exempt), or Green (RoHS & no Sb/Br) - please check <http://www.ti.com/productcontent> for the latest availability information and additional product content details.

**TBD:** The Pb-Free/Green conversion plan has not been defined.

**Pb-Free (RoHS):** TI's terms "Lead-Free" or "Pb-Free" mean semiconductor products that are compatible with the current RoHS requirements for all 6 substances, including the requirement that lead not exceed 0.1% by weight in homogeneous materials. Where designed to be soldered at high temperatures, TI Pb-Free products are suitable for use in specified lead-free processes.

**Pb-Free (RoHS Exempt):** This component has a RoHS exemption for either 1) lead-based flip-chip solder bumps used between the die and package, or 2) lead-based die adhesive used between the die and leadframe. The component is otherwise considered Pb-Free (RoHS compatible) as defined above.

**Green (RoHS & no Sb/Br):** TI defines "Green" to mean Pb-Free (RoHS compatible), and free of Bromine (Br) and Antimony (Sb) based flame retardants (Br or Sb do not exceed 0.1% by weight in homogeneous material)

- (3) MSL, Peak Temp. - The Moisture Sensitivity Level rating according to the JEDEC industry standard classifications, and peak solder temperature.
- (4) There may be additional marking, which relates to the logo, the lot trace code information, or the environmental category on the device.
- (5) Multiple Device Markings will be inside parentheses. Only one Device Marking contained in parentheses and separated by a "-" will appear on a device. If a line is indented then it is a continuation of the previous line and the two combined represent the entire Device Marking for that device.
- (6) Lead/Ball Finish - Orderable Devices may have multiple material finish options. Finish options are separated by a vertical ruled line. Lead/Ball Finish values may wrap to two lines if the finish value exceeds the maximum column width.

**Important Information and Disclaimer:**The information provided on this page represents TI's knowledge and belief as of the date that it is provided. TI bases its knowledge and belief on information provided by third parties, and makes no representation or warranty as to the accuracy of such information. Efforts are underway to better integrate information from third parties. TI has taken and continues to take reasonable steps to provide representative and accurate information but may not have conducted destructive testing or chemical analysis on incoming materials and chemicals. TI and TI suppliers consider certain information to be proprietary, and thus CAS numbers and other limited information may not be available for release.

In no event shall TI's liability arising out of such information exceed the total purchase price of the TI part(s) at issue in this document sold by TI to Customer on an annual basis.

## TAPE AND REEL INFORMATION



### QUADRANT ASSIGNMENTS FOR PIN 1 ORIENTATION IN TAPE



\*All dimensions are nominal

Device	Package Type	Package Drawing	Pins	SPQ	Reel Diameter (mm)	Reel Width W1 (mm)	A0 (mm)	B0 (mm)	K0 (mm)	P1 (mm)	W (mm)	Pin1 Quadrant
THS1030CPWR	TSSOP	PW	28	2000	330.0	16.4	6.9	10.2	1.8	12.0	16.0	Q1
THS1030IPWR	TSSOP	PW	28	2000	330.0	16.4	6.9	10.2	1.8	12.0	16.0	Q1

**TAPE AND REEL BOX DIMENSIONS**

\*All dimensions are nominal

Device	Package Type	Package Drawing	Pins	SPQ	Length (mm)	Width (mm)	Height (mm)
THS1030CPWR	TSSOP	PW	28	2000	367.0	367.0	38.0
THS1030IPWR	TSSOP	PW	28	2000	367.0	367.0	38.0

DW (R-PDSO-G28)

PLASTIC SMALL OUTLINE

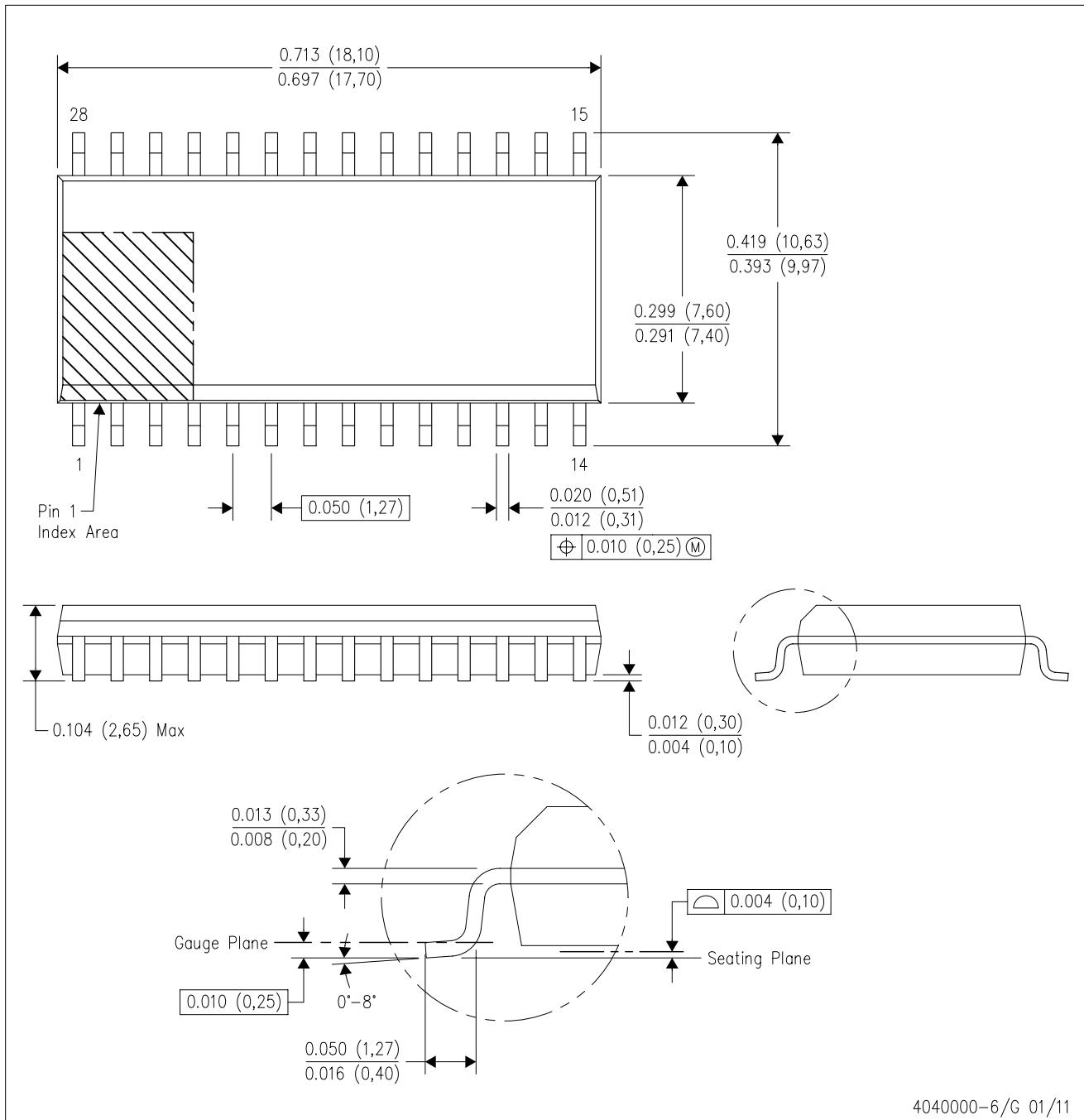

4040000-6/G 01/11

- NOTES:
- All linear dimensions are in inches (millimeters). Dimensioning and tolerancing per ASME Y14.5M-1994.
  - This drawing is subject to change without notice.
  - Body dimensions do not include mold flash or protrusion not to exceed 0.006 (0,15).
  - Falls within JEDEC MS-013 variation AE.

PW (R-PDSO-G28)

PLASTIC SMALL OUTLINE

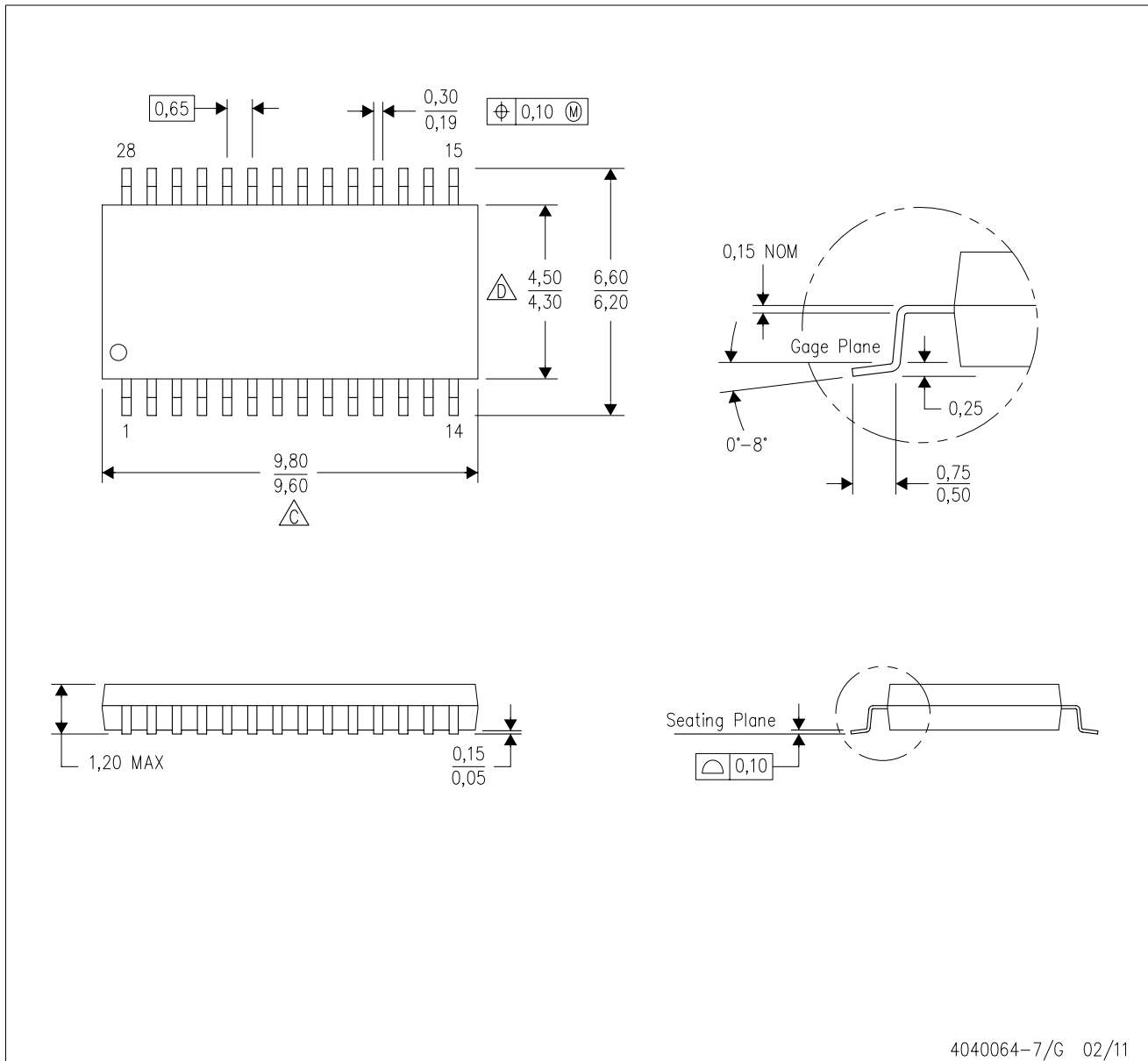

4040064-7/G 02/11

- NOTES:
- A. All linear dimensions are in millimeters. Dimensioning and tolerancing per ASME Y14.5M-1994.
  - B. This drawing is subject to change without notice.
  - C. Body length does not include mold flash, protrusions, or gate burrs. Mold flash, protrusions, or gate burrs shall not exceed 0,15 each side.
  - D. Body width does not include interlead flash. Interlead flash shall not exceed 0,25 each side.
  - E. Falls within JEDEC MO-153

PW (R-PDSO-G28)

PLASTIC SMALL OUTLINE

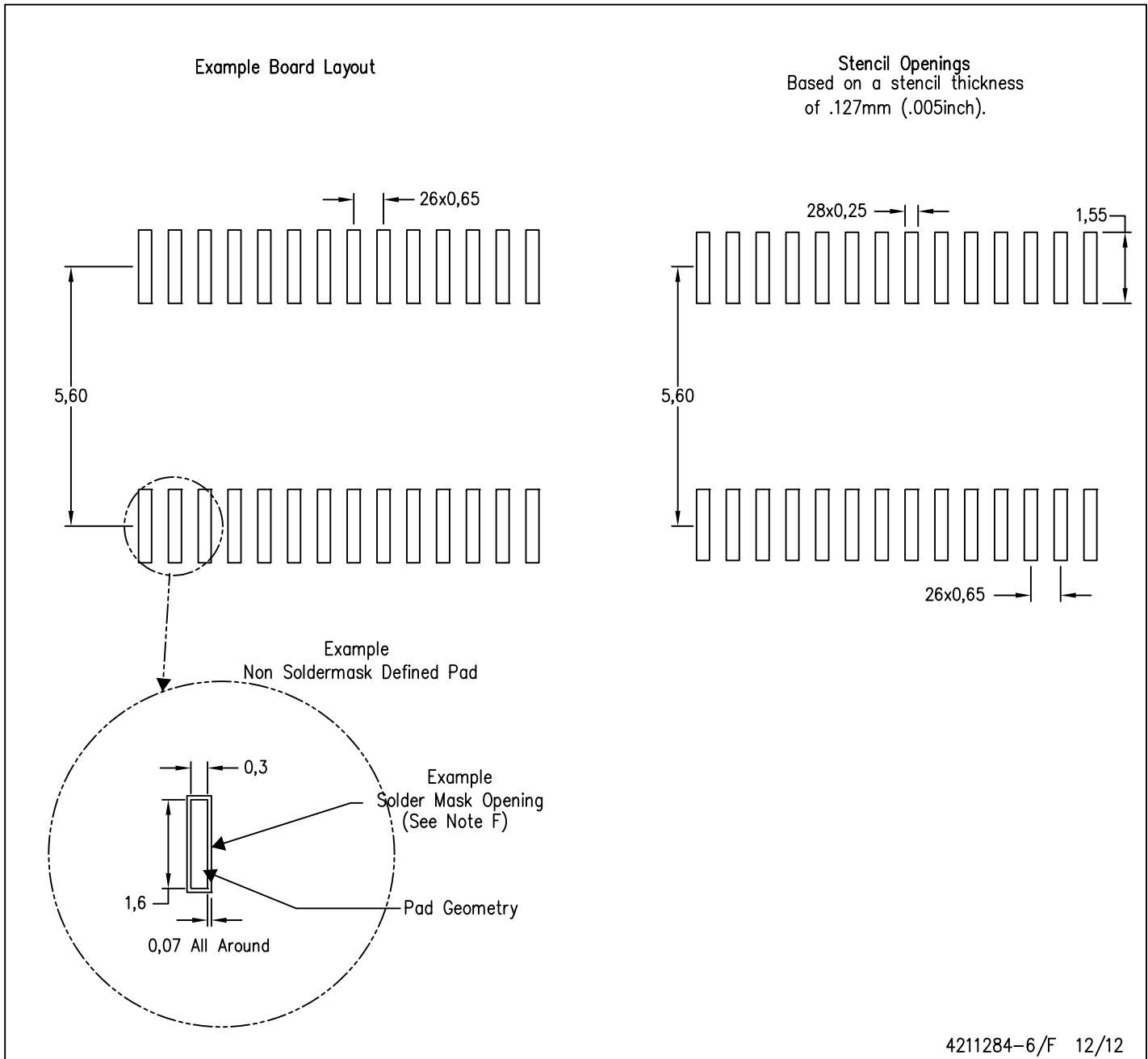

- NOTES:
- A. All linear dimensions are in millimeters.
  - B. This drawing is subject to change without notice.
  - C. Publication IPC-7351 is recommended for alternate design.
  - D. Laser cutting apertures with trapezoidal walls and also rounding corners will offer better paste release. Customers should contact their board assembly site for stencil design recommendations. Refer to IPC-7525 for other stencil recommendations.
  - E. Customers should contact their board fabrication site for solder mask tolerances between and around signal pads.

PW (R-PDSO-G28)

PLASTIC SMALL OUTLINE

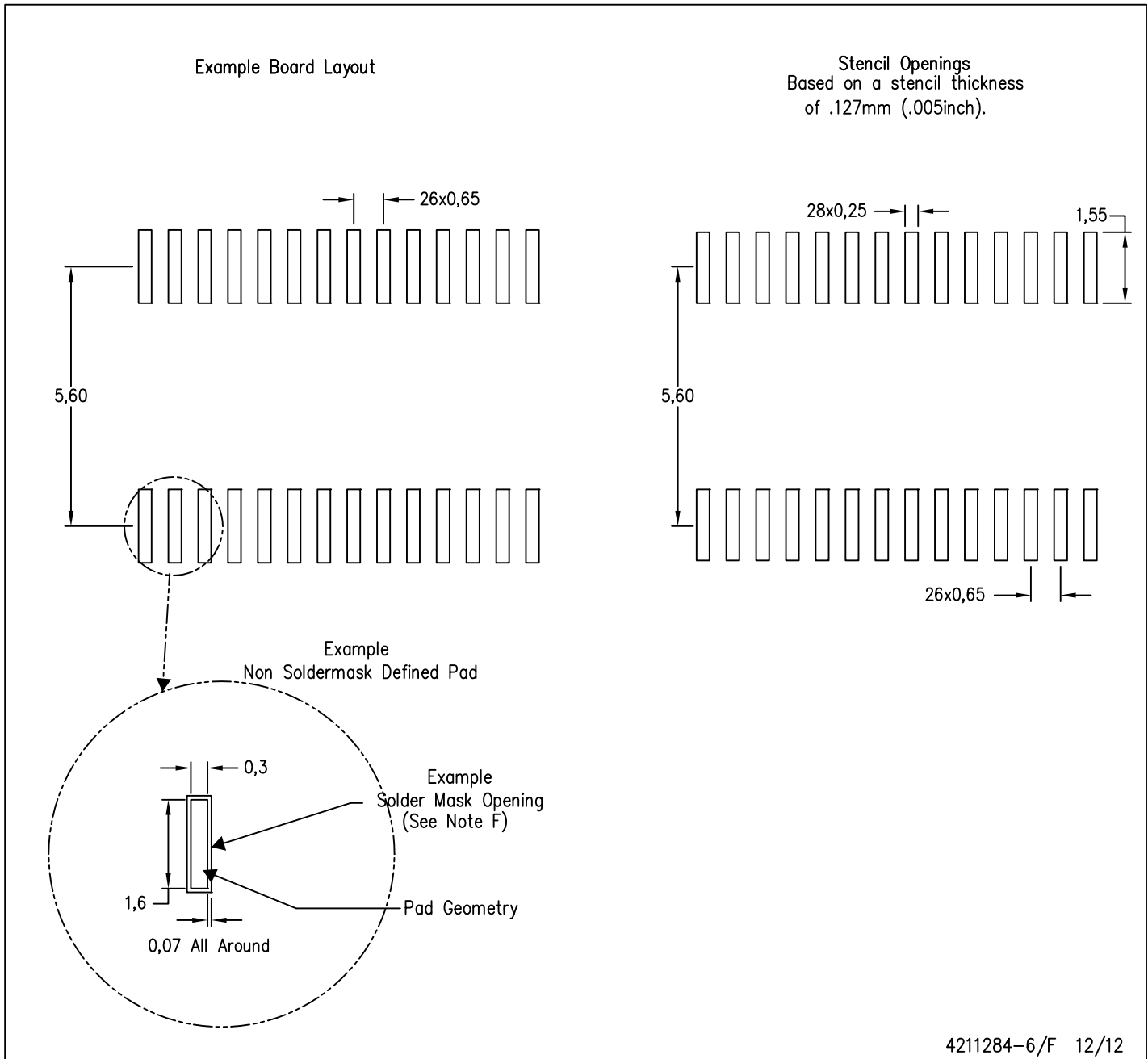

- NOTES:
- A. All linear dimensions are in millimeters.
  - B. This drawing is subject to change without notice.
  - C. Publication IPC-7351 is recommended for alternate design.
  - D. Laser cutting apertures with trapezoidal walls and also rounding corners will offer better paste release. Customers should contact their board assembly site for stencil design recommendations. Refer to IPC-7525 for other stencil recommendations.
  - E. Customers should contact their board fabrication site for solder mask tolerances between and around signal pads.

## IMPORTANT NOTICE

Texas Instruments Incorporated and its subsidiaries (TI) reserve the right to make corrections, enhancements, improvements and other changes to its semiconductor products and services per JESD46, latest issue, and to discontinue any product or service per JESD48, latest issue. Buyers should obtain the latest relevant information before placing orders and should verify that such information is current and complete. All semiconductor products (also referred to herein as "components") are sold subject to TI's terms and conditions of sale supplied at the time of order acknowledgment.

TI warrants performance of its components to the specifications applicable at the time of sale, in accordance with the warranty in TI's terms and conditions of sale of semiconductor products. Testing and other quality control techniques are used to the extent TI deems necessary to support this warranty. Except where mandated by applicable law, testing of all parameters of each component is not necessarily performed.

TI assumes no liability for applications assistance or the design of Buyers' products. Buyers are responsible for their products and applications using TI components. To minimize the risks associated with Buyers' products and applications, Buyers should provide adequate design and operating safeguards.

TI does not warrant or represent that any license, either express or implied, is granted under any patent right, copyright, mask work right, or other intellectual property right relating to any combination, machine, or process in which TI components or services are used. Information published by TI regarding third-party products or services does not constitute a license to use such products or services or a warranty or endorsement thereof. Use of such information may require a license from a third party under the patents or other intellectual property of the third party, or a license from TI under the patents or other intellectual property of TI.

Reproduction of significant portions of TI information in TI data books or data sheets is permissible only if reproduction is without alteration and is accompanied by all associated warranties, conditions, limitations, and notices. TI is not responsible or liable for such altered documentation. Information of third parties may be subject to additional restrictions.

Resale of TI components or services with statements different from or beyond the parameters stated by TI for that component or service voids all express and any implied warranties for the associated TI component or service and is an unfair and deceptive business practice. TI is not responsible or liable for any such statements.

Buyer acknowledges and agrees that it is solely responsible for compliance with all legal, regulatory and safety-related requirements concerning its products, and any use of TI components in its applications, notwithstanding any applications-related information or support that may be provided by TI. Buyer represents and agrees that it has all the necessary expertise to create and implement safeguards which anticipate dangerous consequences of failures, monitor failures and their consequences, lessen the likelihood of failures that might cause harm and take appropriate remedial actions. Buyer will fully indemnify TI and its representatives against any damages arising out of the use of any TI components in safety-critical applications.

In some cases, TI components may be promoted specifically to facilitate safety-related applications. With such components, TI's goal is to help enable customers to design and create their own end-product solutions that meet applicable functional safety standards and requirements. Nonetheless, such components are subject to these terms.

No TI components are authorized for use in FDA Class III (or similar life-critical medical equipment) unless authorized officers of the parties have executed a special agreement specifically governing such use.

Only those TI components which TI has specifically designated as military grade or "enhanced plastic" are designed and intended for use in military/aerospace applications or environments. Buyer acknowledges and agrees that any military or aerospace use of TI components which have **not** been so designated is solely at the Buyer's risk, and that Buyer is solely responsible for compliance with all legal and regulatory requirements in connection with such use.

TI has specifically designated certain components as meeting ISO/TS16949 requirements, mainly for automotive use. In any case of use of non-designated products, TI will not be responsible for any failure to meet ISO/TS16949.

### Products

Audio	<a href="http://www.ti.com/audio">www.ti.com/audio</a>
Amplifiers	<a href="http://amplifier.ti.com">amplifier.ti.com</a>
Data Converters	<a href="http://dataconverter.ti.com">dataconverter.ti.com</a>
DLP® Products	<a href="http://www.dlp.com">www.dlp.com</a>
DSP	<a href="http://dsp.ti.com">dsp.ti.com</a>
Clocks and Timers	<a href="http://www.ti.com/clocks">www.ti.com/clocks</a>
Interface	<a href="http://interface.ti.com">interface.ti.com</a>
Logic	<a href="http://logic.ti.com">logic.ti.com</a>
Power Mgmt	<a href="http://power.ti.com">power.ti.com</a>
Microcontrollers	<a href="http://microcontroller.ti.com">microcontroller.ti.com</a>
RFID	<a href="http://www.ti-rfid.com">www.ti-rfid.com</a>
OMAP Applications Processors	<a href="http://www.ti.com/omap">www.ti.com/omap</a>
Wireless Connectivity	<a href="http://www.ti.com/wirelessconnectivity">www.ti.com/wirelessconnectivity</a>

### Applications

Automotive and Transportation	<a href="http://www.ti.com/automotive">www.ti.com/automotive</a>
Communications and Telecom	<a href="http://www.ti.com/communications">www.ti.com/communications</a>
Computers and Peripherals	<a href="http://www.ti.com/computers">www.ti.com/computers</a>
Consumer Electronics	<a href="http://www.ti.com/consumer-apps">www.ti.com/consumer-apps</a>
Energy and Lighting	<a href="http://www.ti.com/energy">www.ti.com/energy</a>
Industrial	<a href="http://www.ti.com/industrial">www.ti.com/industrial</a>
Medical	<a href="http://www.ti.com/medical">www.ti.com/medical</a>
Security	<a href="http://www.ti.com/security">www.ti.com/security</a>
Space, Avionics and Defense	<a href="http://www.ti.com/space-avionics-defense">www.ti.com/space-avionics-defense</a>
Video and Imaging	<a href="http://www.ti.com/video">www.ti.com/video</a>

### TI E2E Community

[e2e.ti.com](http://e2e.ti.com)