

Integrated Low Profile Transceiver Module for Telecom Applications - IrDA Standard



Description

The miniaturized TFDU4203 is an ideal transceiver for applications in telecommunications like mobile phones and pagers. The device is mechanically designed for lowest profile with a height of only 2.8 mm. The infrared transceiver is compatible to the IrDA® IrPHY specification up to a data rate of 115 kbit/s.

The transceiver can be operated without external current limiting resistor to achieve full SIR compliance (range > 1 m in full ± 15° cone).

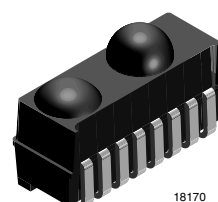

Features

- Package dimension:
L 7.1 mm x W 4.7 mm x H 2.8 mm
- Compatible to the latest IrDA IrPHY standard
- CIR remote control operation:
typical transmission range 8 m using standard RC-receivers. Receives RC-commands with typical specified sensitivity.
- SMD side view
- Lowest power consumption 65 µA, receive mode, 0.01 µA shutdown current
- Built-in current limitation
- Output intensity adjustable beyond IrDA low power
- Supply voltage range 2.4 V to 5.5 V operational down to 2.0 V



- Fewest external components
- Eye safety: double safety
Measures: Limited optical output pulse duration, limited optical output intensity
IEC 60825-1, 2001: class 1
- Tri-state output (RXD)
- High EMI immunity
- SD pin
- Lead (Pb)-free device
- Qualified for lead (Pb)-free and Sn/Pb processing (MSL4)
- Device in accordance with RoHS 2002/95/EC and WEEE 2002/96/EC

Applications

- Mobile phones
- Pagers
- Personal digital assistants (PDA)
- Hand-held battery operated equipment

Parts Table

Part	Description	Qty/reel
TFDU4203-TR1	Orientated in carrier tape for side view in mounting	750 pcs
TFDU4203-TR3	Orientated in carrier tape for side view in mounting	2250 pcs

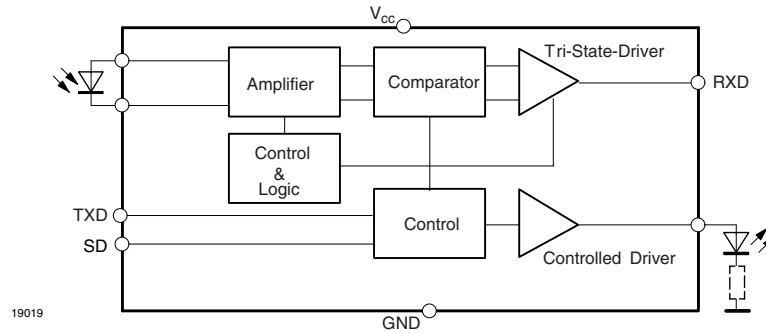
Functional Block Diagram

Pin Description

Pin number	Function	Description	I/O	Active
1	IRED GND	IRED cathode, ground		
2	IRED GND	IRED cathode, ground		
3	RXD	Output, received data, tri-state, floating in shutdown mode	O	Low
4	V _{CC}	Supply voltage		
5	GND	Ground		
6	GND	Ground		
7	TXD	Input, transmit data	I	High
8	SD	Shutdown	I	High

Pinout

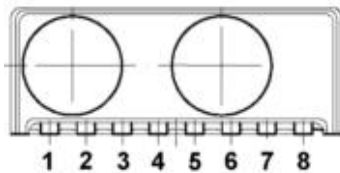
TFDU4203
weight 100 mg



18228

Absolute Maximum Ratings

Reference Point pin 8, unless otherwise noted.

Parameter	Test conditions	Symbol	Min.	Typ.	Max.	Unit
Supply voltage range		V _{CC}	- 0.5		+ 6	V
Input current	all pins				10	mA
Output sink current					25	mA
Power dissipation		P _{tot}			200	mW
Junction temperature		T _J			125	°C
Ambient temperature range (operating)		T _{amb}	- 25		85	°C
Storage temperature range		T _{stg}	- 40		100	°C
Soldering temperature	see the chapter "Soldering conditions" for lead-bearing and Pb-free processing				260	°C
Average IRED current		I _{IRED(DC)}			125	mA
Repetitive pulsed IRED current	< 90 μs, t _{on} < 20 %	I _{IRED(RP)}			500	mA
Transmitter data input voltage		V _{TXD}	- 0.5		6	V
Receiver data output voltage		V _{RXD}	- 0.5		6	V

Eye safety information

Parameter	Test conditions	Symbol	Min.	Typ.	Max.	Unit
Virtual source size (TFDU4203 only)	Method: (1 - 1/e) encircled energy	d		2		mm

Note:

Compatible to Class 1 operation of IEC 60825 or EN60825 with worst case IrDA SIR pulse pattern, 115.2 kbit/s

Electrical Characteristics

Transceiver

Parameter	Test conditions	Symbol	Min.	Typ.	Max.	Unit
Supported data rates	base band		9.6		115.2	kbit/s
Supply voltage range	operational down to 2.0 V	V_{CC}	2.4		5.5	V
Supply current	$V_{CC} = 2.4\text{ V to }5.5\text{ V}$, $E_e = 0$, receive mode, full temperature range	I_S		65	100	μA
	$V_{CC} = 2.4\text{ V to }5.5\text{ V}$, 10 klx sunlight, receive mode or transmit mode, full temperature range, no signal	I_S		70	100	μA
	$V_{CC} = 2.7\text{ V}$ 115.2 kbit/s transmission, receive mode, nose to nose operation	I_S		1		mA
Supply current, at V_{CCP}	shutdown mode, entire temperature range	$I_{S\text{shutdown}}$		0.02	1	μA
	$V_{CC} = 5.5\text{ V}$, 20 °C	$I_{S\text{shutdown}}$			10	nA
IREd peak current transmitting	$I_e = 40\text{ mW/sr}$, no external resistor $V_{CCP} = 2.7\text{ V}$, equivalent to SIR standard	I_{Str}			360	mA
Transceiver 'power on' settling time	time from switching on V_{CC} to established specified operation				1	ms



Optoelectronic Characteristics

Receiver

Tested for the following parameters ($V_{CC} = 2.4\text{ V to }5.5\text{ V}$, $-25\text{ }^{\circ}\text{C to }+85\text{ }^{\circ}\text{C}$, unless otherwise stated).

Parameter	Test Conditions	Symbol	Min.	Typ.	Max.	Unit
Minimum detection threshold irradiance (logic high receiver input irradiance)	$ \alpha \leq \pm 15^{\circ}$, $V_{CC} = 2.0\text{ V to }5.5\text{ V}$	$E_{e, \text{min.}}$		25 (2.5)	50 (5)	mW/m^2 ($\mu\text{W/cm}^2$)
	2.0 V, 25 $^{\circ}\text{C}$ tested	$E_{e, \text{min.}}$		50	100	mW/m^2
Maximum detection threshold irradiance	$ \alpha \leq \pm 90^{\circ}$, $V_{CC} = 5\text{ V}$	$E_{e, \text{max.}}$	3300 (330)	5000 (500)		W/m^2 (mW/cm^2)
	$ \alpha \leq \pm 90^{\circ}$, $V_{CC} = 3\text{ V}$	$E_{e, \text{max.}}$	8000 (800)	15000 (1500)		W/m^2 (mW/cm^2)
Logic low receiver input irradiance		$E_{e, \text{max.,low}}$			4 (0.4)	mW/m^2 ($\mu\text{W/cm}^2$)
Output voltage RXD	active, $C = 15\text{ pF}$	V_{OL}	0		0.5	V
	non active, $C = 15\text{ pF}$	V_{OH}	$V_{CC} - 0.5$			V
Output current RXD	$V_{OL} < 0.5\text{ V}$				4	mA
Rise time at load	$C = 15\text{ pF}$, $R = 2.2\text{ k}\Omega$	t_r	20		70	ns
Fall time at load	$C = 15\text{ pF}$, $R = 2.2\text{ k}\Omega$	t_f	20		70	ns
RXD signal electrical output pulse width	2.4 kbit/s, input pulse width 1.41 μs to 3/16 of bit duration	t_p	1.41		20	μs
	115.2 kbit/s, input pulse width 1.41 μs to 3/16 of bit duration	t_p	1.41		4.5	μs
Output delay time (RXD), leading edge optical input to electrical output	output level = $0.5 \times V_{CC}$ at 40 mW/m^2	t_{dl}		1	2	μs
Jitter, leading edge of output signal	over a period of 10 bit, 115.2 kbit/s	t_j			400	ns
Output delay time (RXD), trailing edge optical input to electrical output	output level = $0.5 \times V_{CC}$ at 40 mW/m^2	t_{dt}			6.5	μs
Power on time, SD recovery time				0.1	1	ms
Latency		t_L		100	200	μs

Transmitter

Parameter	Test conditions	Symbol	Min.	Typ.	Max.	Unit
Logic low shutdown input voltage ^{*)}		$V_{IL(TXD)}$	- 0.5		$0.15 \times V_{CC}$	V
Logic high shutdown input voltage ^{*)}		$V_{IH(TXD)}$	$0.8 \times V_{CC}$		6	V
Logic low transmitter input voltage ^{*)}		$V_{IL(TXD)}$	0.5		$0.81 \times V_{CC}$	V
Logic high transmitter input voltage ^{*)}		$V_{IH(TXD)}$	$0.8 \times V_{CC}$		6	V
Optical output radiant intensity	$ \alpha \leq \pm 15^\circ$, $I_{F1} = 320$ mA, Internally current controlled ^{**)} , voltage range 2.7 V to 5.5 V ^{*)}	I_e	45			mW/sr
Peak emission wavelength		λ_p	880		900	nm
Spectral emission bandwidth				40		nm
Optical rise/fall time	115.2 kHz square wave signal (duty cycle 1 : 1)				200	ns
Optical output pulse duration	input pulse duration 1.6 μ s		1.5	1.6	1.7	μ s
Output radiant intensity	logic low level				0.04	μ W/sr
Overshoot, optical					25	%
Rising edge peak to peak jitter	over a period of 10 bits, independent of information content	t_j			0.2	μ s

Notes:

^{*)} Recommended logic levels for minimum shutdown current. The CMOS decision level is $0.5 \times V_{CC}$.

^{**)} Add external resistor for $V_{CC} > 4$ V to prevent thermal overload, see Fig. 3.

Truth table

Inputs			Outputs	
SD	TXD	Optical input Irradiance mW/m ²	RXD	Transmitter
high	x	x	floating	0
low	high	x	high	I_e
low	high ≥ 25 μ s	x	high	0
low	low	< 4	high	0
low	low	> Min. Detection Threshold Irradiance	x	0
low	low	> Max. Detection Threshold Irradiance	x	0

Application Hints

The TFDU4203 does not need any external components when operated with a "clean" power supply. In a more noisy ambient it is recommended to add a capacitor C1 (4.7 μ F Tantalum) and a resistor R1 ($\leq 3 \Omega$) for noise suppression. In addition the capacitor is needed to prevent a pulse distortion when the power supply is not able to generate the peak currents or inductive wiring is used. A combination of a tantalum with a ceramics capacitor will be efficient to attenuate both, RF and LF if RF noise is present. The value is dependent on the power supply quality. A good choice is between 4.7 μ F and 10 μ F.

Shut down

To shut down the TFDU4203 into a standby mode the SD pin has to be set active.

Latency

The receiver is in specified conditions after the defined latency.

In a UART related application after that time after the last transmitted signal (IrDA specifies 500 μ s maximum for low power applications and 10 ms maximum for standard) the receiver buffer of the UART must be cleared. Therefore the transceiver has to wait at least the specified latency after receiving the last bit before starting the transmission to be sure that the corresponding receiver is in a defined state.

For more application circuits, see IrDC design guide and TOIM4232 data sheet.

Recommended Circuit Diagram

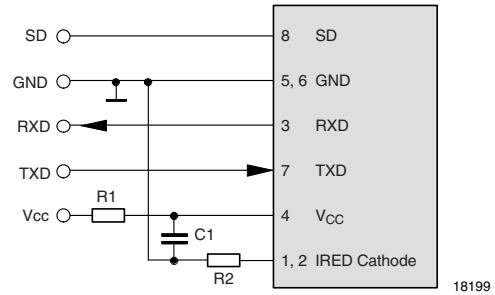

Recommended Application Circuit Components

Component	Recommended value	Vishay part number
C1	4.7 μ F, 16 V	293D 475X9 016B 2T
R1	5 Ω maximum	

Note:

This is a recommendation for a combination to start with to exclude power supply effects. Optimum, from a costs point of view, to work without both.

Temperature Derating Diagram

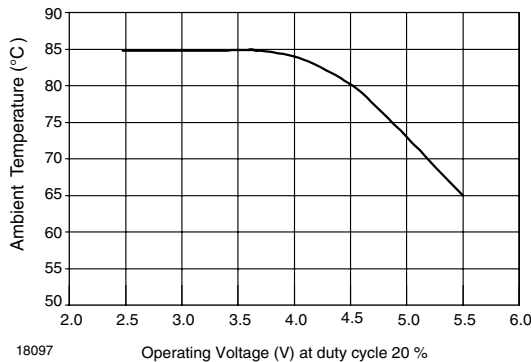

Figure 1. Temperature Derating Diagram

The temperature derating diagram shows the maximum operating temperature when the device is operated without external current limiting resistor. A power dissipating resistor of 2 Ω is recommended from the cathode of the IRED to Ground for supply voltages above 4 V. In that case the device can be operated up to 85 $^{\circ}$ C, too.

Recommended Solder Profiles

Solder Profile for Sn/Pb Soldering

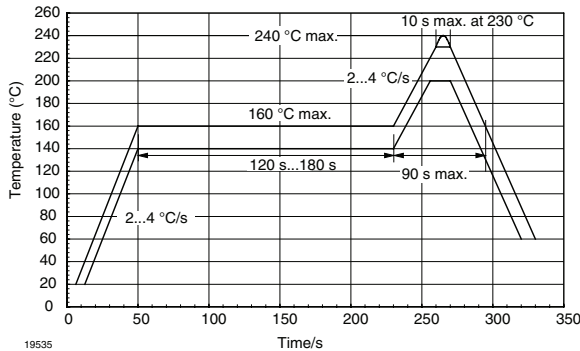

Figure 2. Recommended Solder Profile for Sn/Pb Soldering

Lead (Pb)-Free, Recommended Solder Profile

The TFDU4203 is a lead (Pb)-free transceiver and qualified for lead (Pb)-free processing. For lead (Pb)-free solder paste like Sn (3.0 - 4.0) Ag (0.5 - 0.9) Cu, there are two standard reflow profiles: Ramp-Soak-Spike (RSS) and Ramp-To-Spike (RTS). The Ramp-Soak-Spike profile was developed primarily for reflow ovens heated by infrared radiation. With widespread use of forced convection reflow ovens the Ramp-To-Spike profile is used increasingly. Shown below in figure 3 and 4 are VISHAY's recommended profiles for use with the TFDU4203 transceivers. For more details please refer to the application note "SMD Assembly Instructions" (<http://www.vishay.com/docs/82602/82602.pdf>).

A ramp-up rate less than 0.9 °C/s is not recommended. Ramp-up rates faster than 1.3 °C/s could damage an optical part because the thermal conductivity is less than compared to a standard IC.

Wave Soldering

For TFDUxxxx and TFBSxxxx transceiver devices wave soldering is not recommended.

Manual Soldering

Manual soldering is the standard method for lab use. However, for a production process it cannot be recommended because the risk of damage is highly dependent on the experience of the operator. Nevertheless, we added a chapter to the above mentioned application note, describing manual soldering and desoldering.

Storage

The storage and drying processes for all VISHAY transceivers (TFDUxxxx and TFBSxxx) are equivalent to MSL4.

The data for the drying procedure is given on labels on the packing and also in the application note "Taping, Labeling, Storage and Packing" (<http://www.vishay.com/docs/82601/82601.pdf>).

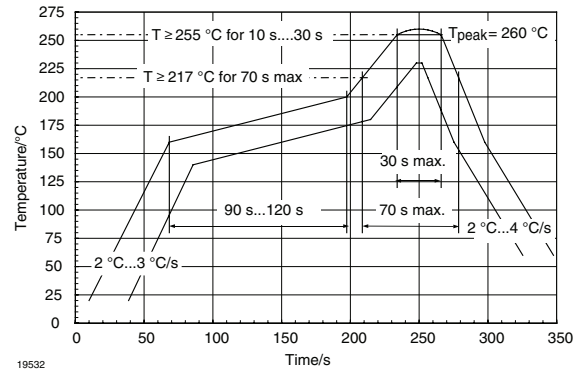

Figure 3. Solder Profile, RSS Recommendation

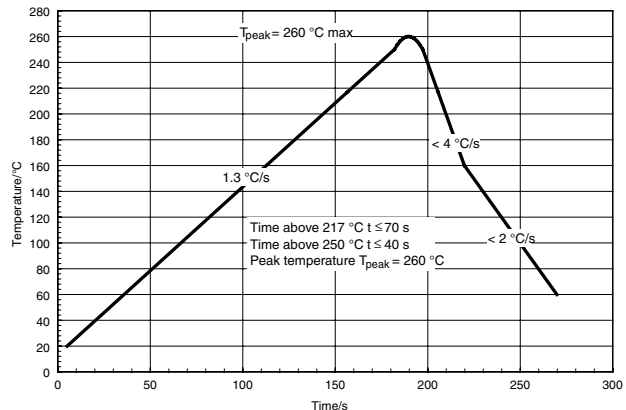
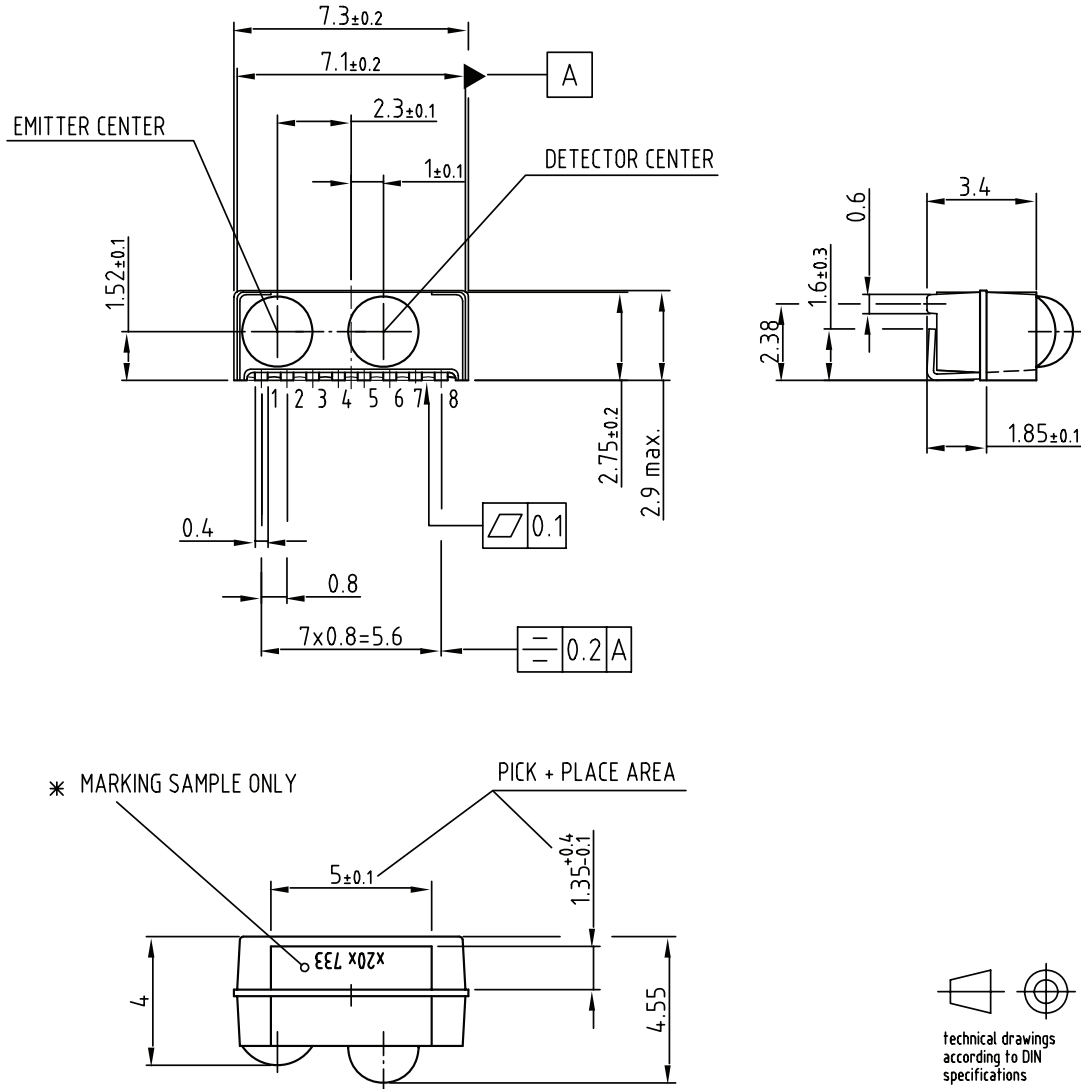

Figure 4. RTS Recommendation

Package Dimensions in mm



* MARKING ORIENTATION
180 DEGREES ALLOWED

19821

Drawing-No.: 6.550-5185.01-4
Issue: 5; 02.09.05

Figure 5. Package Drawing, TFDU4203

Reel Dimensions in mm

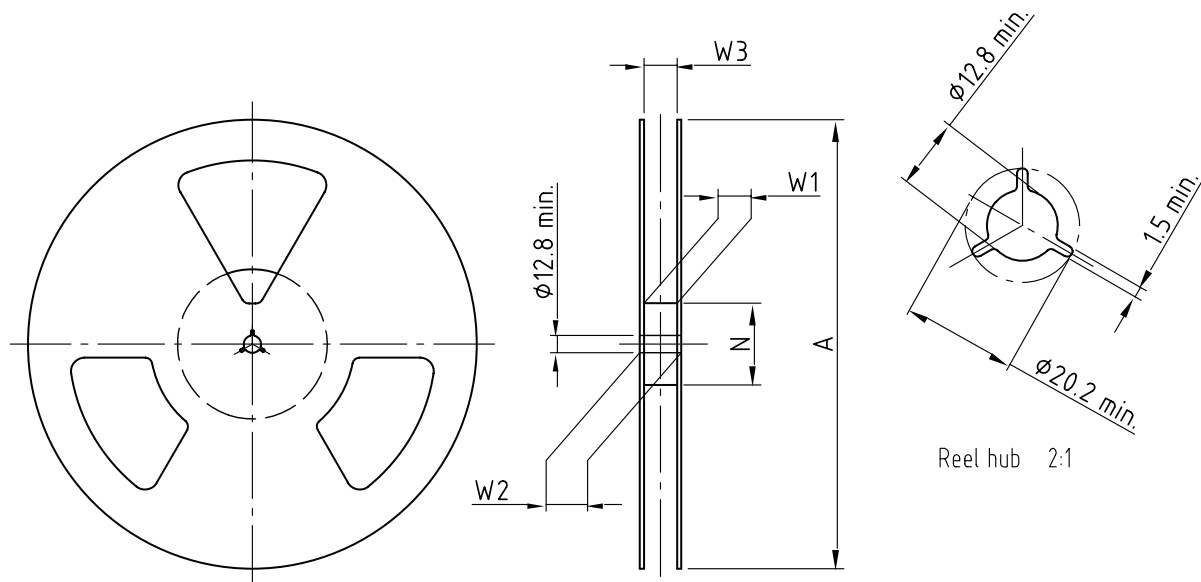

Drawing-No.: 9.800-5090.01-4
 Issue: 1; 29.11.05
 14017

Form of the leave open
 of the wheel is supplier specific.

Dimension acc. to IEC EN 60 286-3

technical drawings
 according to DIN
 specifications

mm	mm	mm	mm	mm	mm	mm
Tape width	A max.	N	W ₁ min.	W ₂ max.	W ₃ min.	W ₃ max.
16	180	60	16.4	22.4	15.9	19.4
16	330	50	16.4	22.4	15.9	19.4

Tape Dimensions in mm

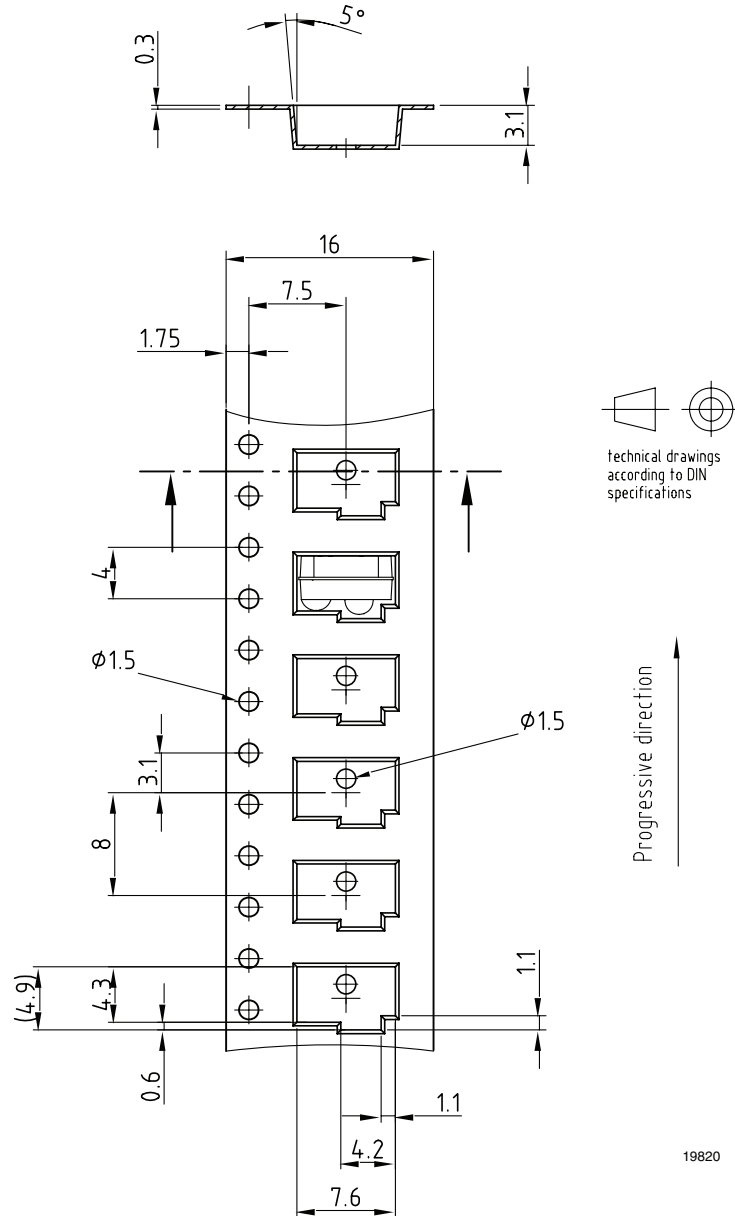

Drawing-No.: 9.700-5227.01-4
 Issue: 3; 03.09.99

Figure 6. Tape Drawing, TFDU4203 for Side View Mounting



Ozone Depleting Substances Policy Statement

It is the policy of Vishay Semiconductor GmbH to

1. Meet all present and future national and international statutory requirements.
2. Regularly and continuously improve the performance of our products, processes, distribution and operating systems with respect to their impact on the health and safety of our employees and the public, as well as their impact on the environment.

It is particular concern to control or eliminate releases of those substances into the atmosphere which are known as ozone depleting substances (ODSs).

The Montreal Protocol (1987) and its London Amendments (1990) intend to severely restrict the use of ODSs and forbid their use within the next ten years. Various national and international initiatives are pressing for an earlier ban on these substances.

Vishay Semiconductor GmbH has been able to use its policy of continuous improvements to eliminate the use of ODSs listed in the following documents.

1. Annex A, B and list of transitional substances of the Montreal Protocol and the London Amendments respectively
2. Class I and II ozone depleting substances in the Clean Air Act Amendments of 1990 by the Environmental Protection Agency (EPA) in the USA
3. Council Decision 88/540/EEC and 91/690/EEC Annex A, B and C (transitional substances) respectively.

Vishay Semiconductor GmbH can certify that our semiconductors are not manufactured with ozone depleting substances and do not contain such substances.

We reserve the right to make changes to improve technical design
and may do so without further notice.

Parameters can vary in different applications. All operating parameters must be validated for each customer application by the customer. Should the buyer use Vishay Semiconductors products for any unintended or unauthorized application, the buyer shall indemnify Vishay Semiconductors against all claims, costs, damages, and expenses, arising out of, directly or indirectly, any claim of personal damage, injury or death associated with such unintended or unauthorized use.

Vishay Semiconductor GmbH, P.O.B. 3535, D-74025 Heilbronn, Germany



Disclaimer

All product specifications and data are subject to change without notice.

Vishay Intertechnology, Inc., its affiliates, agents, and employees, and all persons acting on its or their behalf (collectively, "Vishay"), disclaim any and all liability for any errors, inaccuracies or incompleteness contained herein or in any other disclosure relating to any product.

Vishay disclaims any and all liability arising out of the use or application of any product described herein or of any information provided herein to the maximum extent permitted by law. The product specifications do not expand or otherwise modify Vishay's terms and conditions of purchase, including but not limited to the warranty expressed therein, which apply to these products.

No license, express or implied, by estoppel or otherwise, to any intellectual property rights is granted by this document or by any conduct of Vishay.

The products shown herein are not designed for use in medical, life-saving, or life-sustaining applications unless otherwise expressly indicated. Customers using or selling Vishay products not expressly indicated for use in such applications do so entirely at their own risk and agree to fully indemnify Vishay for any damages arising or resulting from such use or sale. Please contact authorized Vishay personnel to obtain written terms and conditions regarding products designed for such applications.

Product names and markings noted herein may be trademarks of their respective owners.