

**TEA10402V15A0**

# Specification

<b>Product Name</b>	<b>ESD Guard™</b>
<b>Series</b>	<b>TEA Series (Thin Film Air Gap)</b>
<b>Part No</b>	<b>TEA10402V15A0</b>
<b>Size</b>	<b>EIA 0402</b>



## TEA10402V15A0 Engineering Specification

### 1. Scope

TEA series is designed to protect the high-speed data lines against ESD transients. It has very low capacitance, fast turn on times, and cut-off frequency over 10GHz which meets the USB3.1 requirement.

TEA series meets RoHs standards.

### Features

- Protection against ESD voltages and currents (IEC61000-4-2 Level 4)
- Extremely quick response time (<1ns) present ideal ESD protection
- Extremely low capacitance (0.06pF typical)
- Bi-directional device
- SMD (Surface Mount Device)
- Zero signal distortion

### 2. Explanation of Part Number

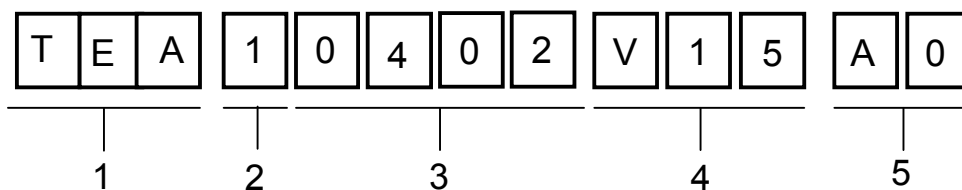

1 : Thin film ESD guard (air-gap type)

2 : Single element

3 : Chip size, EIA 0402

4 : Max rated voltage, VDC

5 : "A0": Model code

### 3. Circuit symbol



### 4. Construction & Dimensions

4.1. Substrate : Alumina

4.2. End termination: Ni/Sn

4.3. Dimensions :

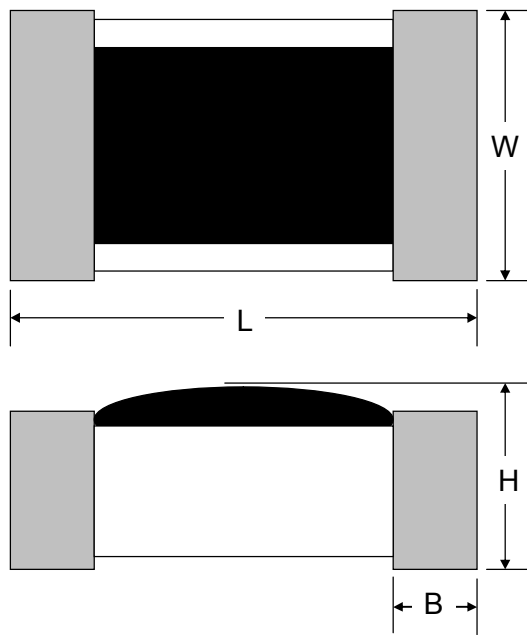

Unit: mm

L	W	H	B
1.0±0.1	0.5±0.1	0.38±0.1	0.25±0.15

## 5. Performance Characteristics

	Symbol	Unit	Min.	Typical	Max.
Rated voltage	$V_{DC}$	V			15
Trigger voltage	$V_t$	V		300	
Clamping voltage	$V_c$	V		20	
Capacitance, @1MHz	$C_p$	pF		0.06	
Response time		ns			1
ESD voltage capability, Contact discharge mode		kV		8	
ESD voltage capability, Air discharge mode		kV		15	
ESD pulse withstand		pulses		1,000	

$V_t$  – measured by Transmission Line Pulse (TLP)

$V_c$  –measured by Transmission Line Pulse (TLP)

$C_p$  – Device capacitance measured with 0Vrms

## 6. General specifications

### 6.1. Temperature Specifications

Operating Temperature range : -40°C to +85°C

### 6.2. Environmental Specifications

Item	Specifications	Test condition	Reference
Thermal Shock	$I_L \leq 10 \mu A$	-40°C to 85°C, 30min/cycle, 5 cycles	JIS C 0025 (1998)Test Na
High Temperature load voltage	$I_L \leq 10 \mu A$	85°C rated voltage, 1000 hrs	MIL-STD-202G Method 108
Solder leach resistance	$I_L \leq 10 \mu A$	260°C, 10sec	MIL-STD-202G Method 210F

$I_L$  – Leakage current measured at 5V after reliability tests.

## 7. Taping Package and Label Marking

### 7.1. Carrier tape dimensions

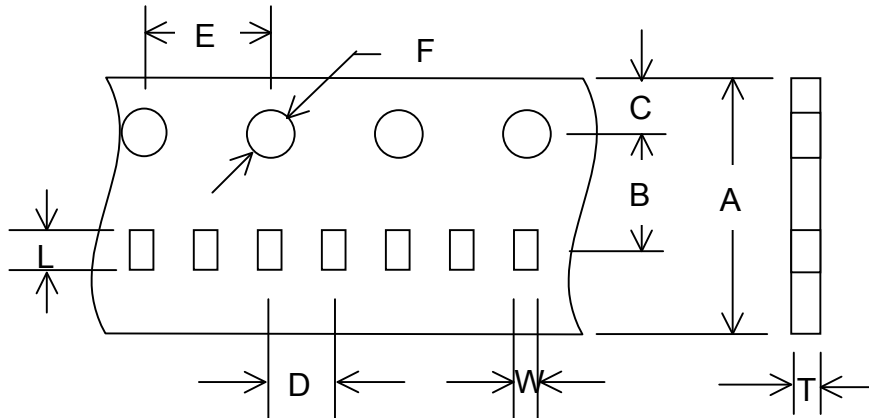

	0402
A	8.00±0.30
B	3.50±0.05
C	1.75±0.10
D	2.00±0.05
E	4.00±0.10
F	1.50±0.10
L	1.19±0.05
W	0.69±0.05
T	0.40±0.03

## 7.2. Taping reel dimensions

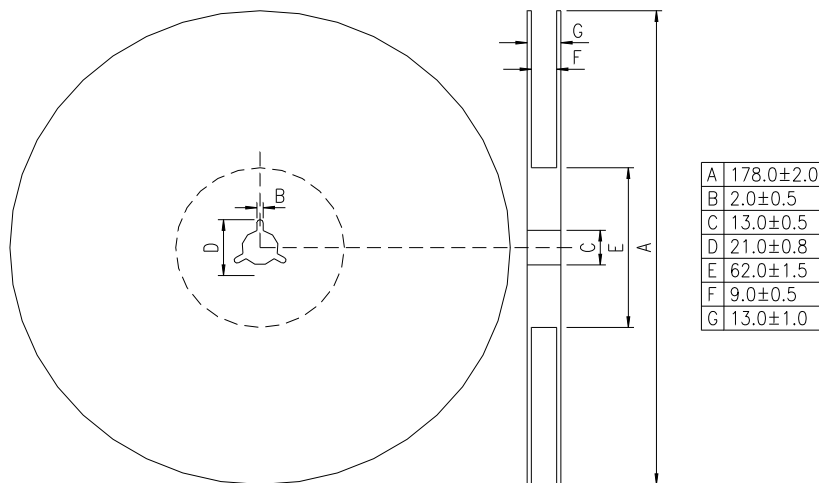

## 7.3. Taping specifications

There is a portion without product in both the head and the end of taping, with cover tape in the head of taping.

## 7.4. Label Marking

A label specified as follows is on the side of reel.

- (1) Part No.
- (2) Quantity
- (3) Lot No.

\* Part No. And Quantity are also marked on outer packaging.

## 7.5. Quantity of products in the taping package

- (1) Standard quantity : 10000pcs/Reel
- (2) Shipping quantity is a multiple of standard quantity.

## 8. Precautions for Handling

### 8.1. Solder cream in reflow soldering

Below refers to the recommended land pattern and printing mask pattern for solder cream.

Print solder in a thickness of 0.15 to 0.2 mm.

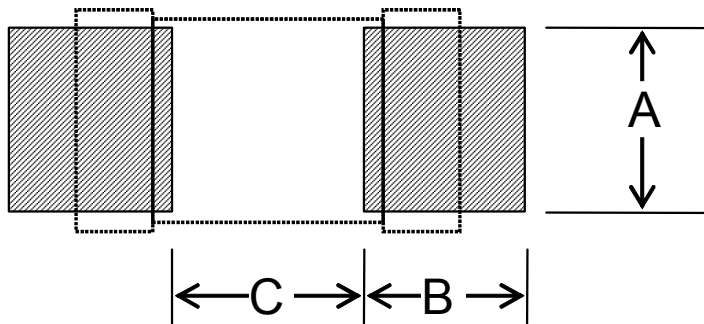

Unit : mm(inch)

A	0.50±0.1 (0.02±0.004)
B	0.50±0.1 (0.02±0.004)
C	0.50±0.1 (0.02±0.004)

### 8.2. Precautions for handling of substrate

Do not exceed to bend the board after soldering this product extremely.

(reference examples)

- Mounting place must be as far as possible from the break line or large holes on the board.
- Do not bend the board extremely in mounting another components.

If necessary, use back-up pin (support pin) to prevent from bending extremely.

- Do not break the board by hand. We recommend using a machine or a jig to break it.

### 8.3. Precautions for soldering

Note that this product will be easily damaged by rapid heating, rapid cooling or local heating.

Do not give heat shock over 100°C in the process of soldering. We recommend preheating and gradual cooling.

### 8.4. Recommended reflow soldering

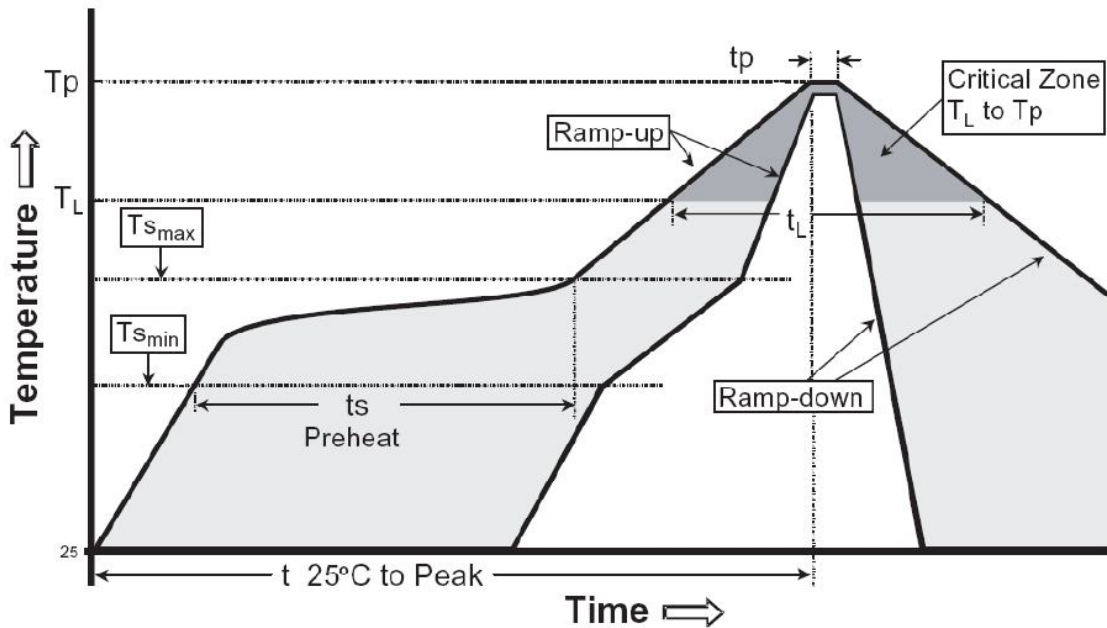

Reference IPC-020c-5-1

Profile Feature	Pb free Assembly
Average Ramp Rate (Ts max to Tp)	3 °C/second max
Preheat <ul style="list-style-type: none"> <li>- Temperature Min (Ts<sub>min</sub>)</li> <li>- Temperature Min (Ts<sub>max</sub>)</li> <li>- Time(ts<sub>min</sub> to ts<sub>min</sub>)</li> </ul>	150°C 200°C 60-180 seconds
Time maintained above: <ul style="list-style-type: none"> <li>- Temperature (T<sub>L</sub>)</li> <li>- Time (t<sub>L</sub>)</li> </ul>	217°C 60-150 seconds
Peak Temperature (T <sub>p</sub> )	260°C +0/-5 °C
Time within 5 °C of actual Peak Temperature (T <sub>p</sub> )	20-40 seconds
Ramp-Down Rate	6 °C/second max.
Time 25°C to Peak Temperature	8 minutes max

### 8.5. Soldering gun procedure

Note the follows, in case of using solder gun for replacement.

- (1) Tip temperature must not exceed 280°C for over 3 seconds by using soldering gun under 30 W.
- (2) Soldering gun tip should not touch this product directly.

### 8.6. Soldering volume

Note that excess of soldering volume might cause crack in this product.

### 8.7. Taping Package Storage Condition

Storage Temperature : 5 to 40 °C

Relative Humidity: < 65%RH

Storage Time : 12 months max