

**FEATURES**

- ※ Compact size
- ※ SMT & Through hole type available
- ※ Different stem height for option

**APPLICATION**

- ※ DVD Players, CD-ROMs
- ※ Automotive
- ※ Telecommunication

**SPECIFICATION**

Contact Rating	5mA, 5V DC
Contact Resistance	500mΩ max.
Insulation Resistance	100MΩ min. 250V DC
Dielectric Strength	250V AC/1 minute
Operating Force	35gf max.
Travel	2mm
Operating Life	50,000 cycles
Operating Temp.	-20°C ~ +70°C
Storage Temp.	-30°C ~ +80°C

**HOW TO ORDER**

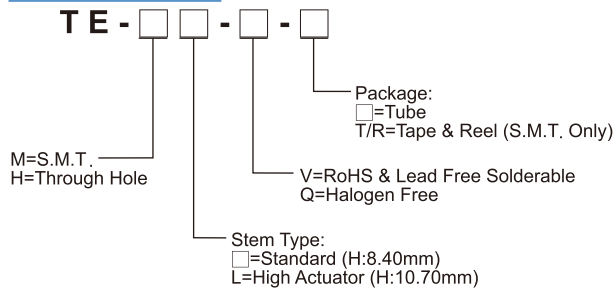

**CIRCUIT**

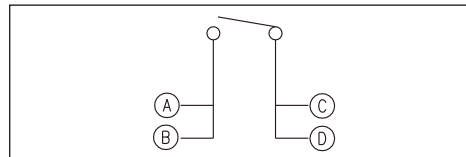

**PACKAGE**

- <Tube>  
72 pcs
- <Tape & Reel>  
TE-M: 500 pcs  
TE-ML: 400 pcs

**TE-ML**

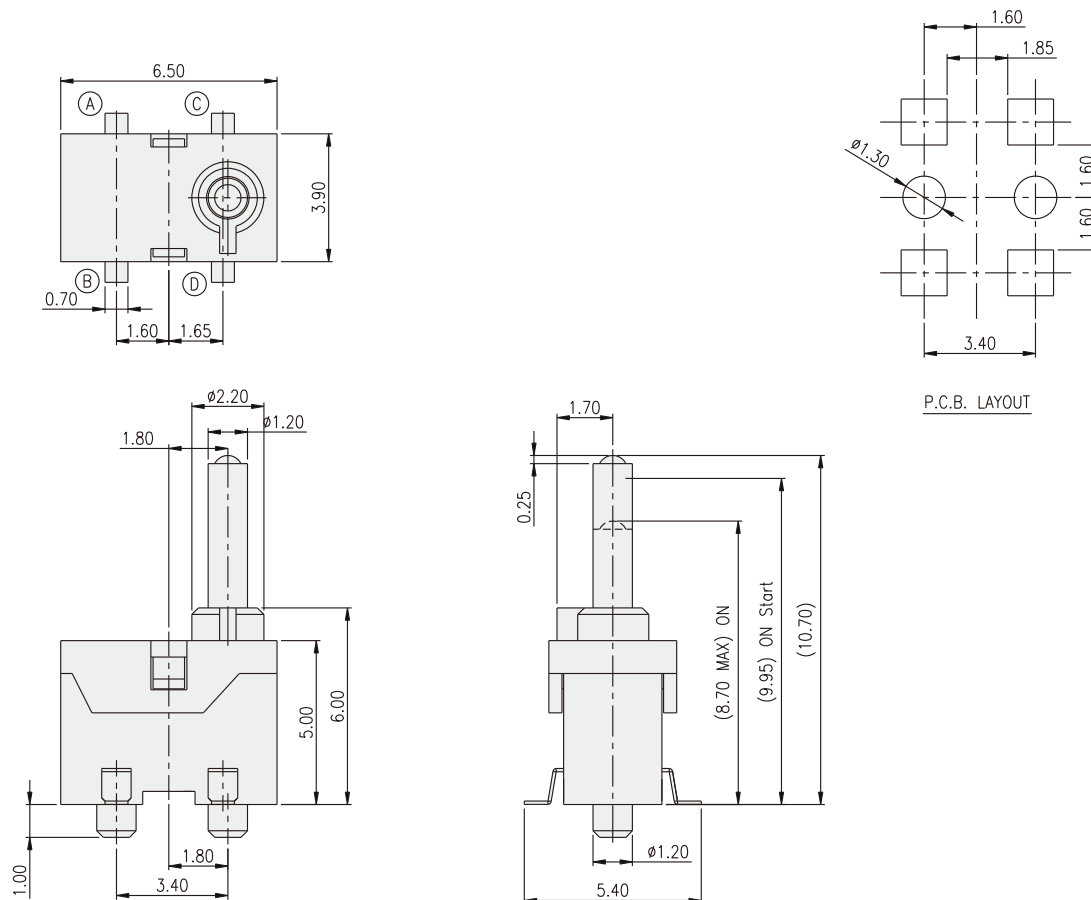

TE-H

