

TDC1044A

Monolithic Video A/D Converter

The TDC1044A is a 25 Msps (Megasample per second) full-parallel analog-to-digital converter, capable of converting an analog signal with full-power frequency components up to 12.5 MHz into 4-bit digital words. Use of a sample-and-hold circuit is not necessary for operation of the TDC1044A. All digital inputs and outputs are TTL compatible.

The TDC1044A consists of 15 latching comparators, encoding logic, and an output register. A single convert signal controls the conversion operation. Output formats are true/inverted binary or true/inverted offset two's complement code.

Rochester Electronics Manufactured Components

Rochester branded components are manufactured using either die/wafers purchased from the original suppliers or Rochester wafers recreated from the original IP. All recreations are done with the approval of the OCM.

Parts are tested using original factory test programs or Rochester developed test solutions to guarantee product meets or exceeds the OCM data sheet.

Quality Overview

- ISO-9001
- AS9120 certification
- Qualified Manufacturers List (QML) MIL-PRF-38535
 - Class Q Military
 - Class V Space Level
- Qualified Suppliers List of Distributors (QSLD)
 - Rochester is a critical supplier to DLA and meets all industry and DLA standards.

Rochester Electronics, LLC is committed to supplying products that satisfy customer expectations for quality and are equal to those originally supplied by industry manufacturers.

The original manufacturer's datasheet accompanying this document reflects the performance and specifications of the Rochester manufactured version of this device. Rochester Electronics guarantees the performance of its semiconductor products to the original OEM specifications. 'Typical' values are for reference purposes only. Certain minimum or maximum ratings may be based on product characterization, design, simulation, or sample testing.

TDC1044A

Monolithic Video A/D Converter

4-Bit, 25 Msp/s

Features

- 4-bit resolution
- 1/4 LSB non-linearity
- Sample-and-hold circuit not required
- 25 Msp/s conversion rate
- Selectable output format
- 16-lead DIP and 20-lead PLCC packages

Applications

- Digital communications
- Video special effects
- Radar data conversion
- Medical imaging

Description

The TDC1044A is a 25 Msp/s (Megasample per second) full-parallel analog-to-digital converter, capable of converting an analog signal with full-power frequency components up to 12.5 MHz into 4-bit digital words. Use of a sample-and-hold circuit is not necessary for operation of the TDC1044A. All digital inputs and outputs are TTL compatible.

The TDC1044A consists of 15 latching comparators, encoding logic, and an output register. A single convert signal controls the conversion operation. Output formats are true/inverted binary or true/inverted offset two's complement codes.

Block Diagram

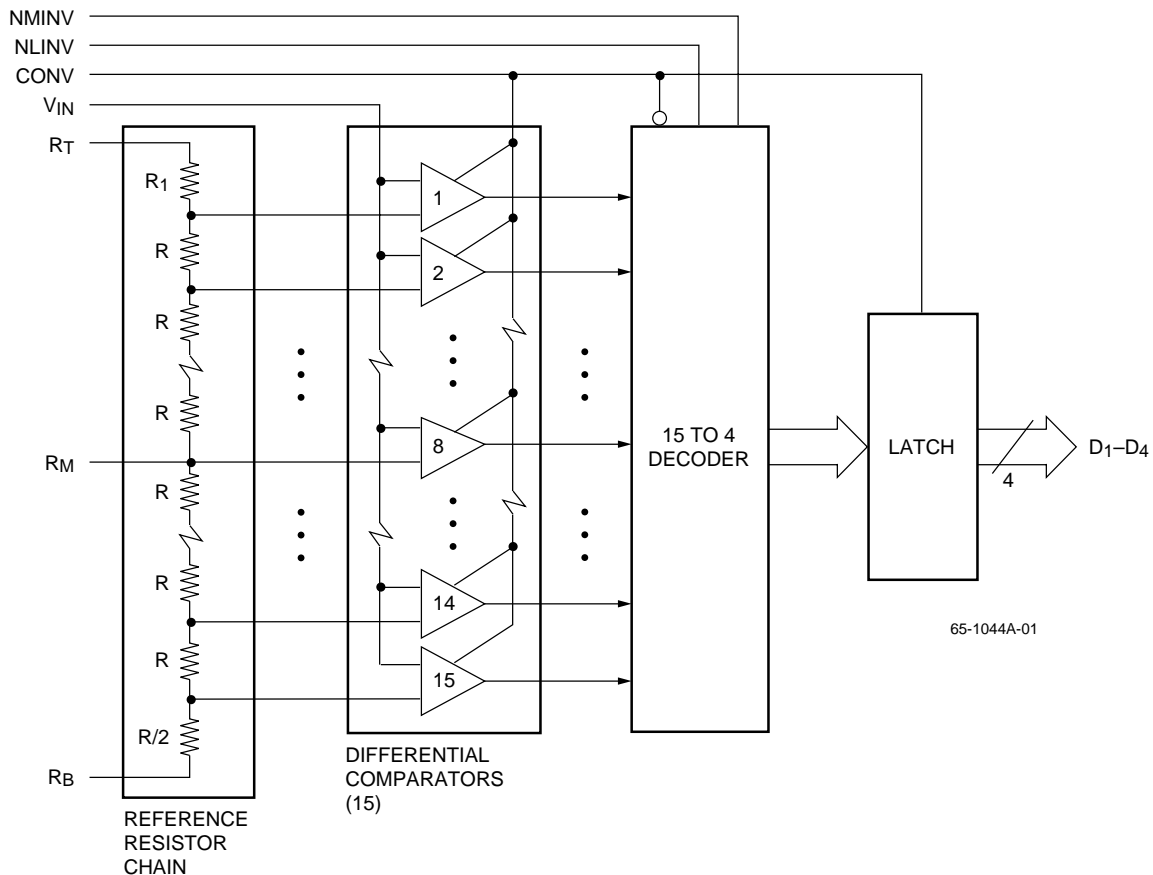

65-1044A-01

Functional Description

General Information

The TDC1044A has three functional sections: a comparator array, encoding logic, and an output register. The comparator array compares the input signal with 15 reference voltages to produce an N-of-15 thermometer code. All the comparators referred to voltages more positive than the input signal will be off, and those referred to voltages more negative than the input signal will be on. Encoding logic converts the N-of-15 code into binary or two's complement coding and can invert either output code. This coding function is controlled by DC signals on pins NMINV and NLINV. The output register holds the output constant between updates.

Power

The TDC1044A operates from two power supply voltages, +5.0V and -5.2V. The return for ICC (the current drawn from the +5.0V supply) is DGND. The return for IEE (the current drawn from the -5.2V supply) is AGND. All power and ground pins must be connected.

Reference

The TDC1044A converts analog signals in the range $V_{RB} \leq V_{IN} \leq V_{RB}$ into digital form. V_{RB} (the voltage applied to RB at the bottom of the reference resistor chain) and V_{RT} (the voltage applied to RB at the top of the reference resistor chain) should be between +0.1V and -1.1V. V_{RT} should be more positive than V_{RB} within that range. The voltage applied across the reference resistor chain ($V_{RT} - V_{RB}$) must be between 0.4V and 1.3V.

Nominal voltages are $V_{RT} = 0.00V$ and $V_{RB} = -1.00V$. These voltages may be varied dynamically up to 10MHz. Due to slight variation in the reference currents with clock and input signals, R_T and R_B should be low-impedance points. For circuits in which the reference is not varied, a bypass capacitor to ground is recommended. If the reference inputs are varied dynamically (as in an Automatic Gain Control circuit), a low-impedance reference source is required.

A reference middle, R_M , is also provided; this may be used as an input to adjust the mid-scale point in order to improve integral linearity. This point may also be used as a tap to supply a mid-scale voltage to offset the analog input. If V_{RM} is used as an output, it must be connected to a high input impedance device which has small input current. Noise at this point may adversely affect the performance of this device.

Controls

Two function control pins, NMINV and NLINV, set the output format to be either straight binary or offset two's complement, in either true or inverted sense, according to Table 1. These pins are active LOW as signified by the prefix "N" in the signal name. They may be tied to VCC for a logic "1" and DGND for a logic "0."

NMINV controls the MSB, D₁; NLINV controls the three LSBs: D₂, D₃ and D₄.

Convert

The TDC1044A requires a CONVert (CONV) signal. A sample is taken (the comparators are latched) within t_{STO} after a rising edge of CONV. The coded result is translated to the output latches on the next rising edge. The outputs hold the previous data a minimum time (t_{HO}) after the rising edge of the CONV signal. New data becomes valid after a maximum delay time, t_D .

Analog Input

The TDC1044A uses latching comparators which cause the input impedance to vary slightly with the signal level. For optimal performance, the source impedance of the driving circuit must be less than 25 Ohms. Within the range of V_{EE} to +0.5V, the input signal will not damage the device. If the input signal is at a voltage between V_{RT} and V_{RB} , the output will be a binary code between 0 and 15 inclusive. A signal outside this range will indicate either full-scale positive or full-scale negative, depending on whether the signal is off-scale in the positive or negative direction.

Outputs

TDC1044A outputs are TTL compatible, and capable of driving four low-power Schottky TTL (54/74 LS) unit loads. The outputs hold the previous data a minimum time (t_{HO}) after the rising edge of the CONV signal. Data becomes valid after a maximum delay time (t_D) after the rising edge of CONV. For optimum performance, 2.2 kOhm pull-up resistors are recommended.

No Connects

Pin 3 of the TDC1044A is labeled No Connect (NC), and has no connection to the chip. Connect this pin to AGND for best noise performance.

Table 1. Output Coding¹

Range	Binary		Offset Two's Complement	
	True	Inverted	True	Inverted
-1.00V FS	NMINV = 1 NLINV = 1	0 0	0 1	1 0
0.000V	0000	1111	1000	0111
-0.067V	0001	1110	1001	0110
-0.133V	0010	1101	1010	0101
-0.200V	0011	1100	1011	0100
-0.267V	0100	1011	1100	0011
-0.333V	0101	1010	1101	0010
-0.400V	0110	1001	1110	0001
-0.467V	0111	1000	1111	0000
-0.533V	1000	0111	0000	1111
-0.600V	1001	0110	0001	1110
-0.667V	1010	0101	0010	1101
-0.733V	1011	0100	0011	1100
-0.800V	1100	0011	0100	1011
-0.867V	1101	0010	0101	1010
-0.933V	1110	0001	0110	1001
-1.000V	1111	0000	0111	1000

Note:

1. Input voltages are at code centers.

Pin Assignments

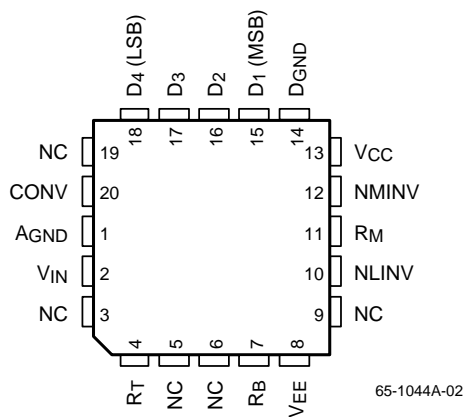

20 Lead PLCC

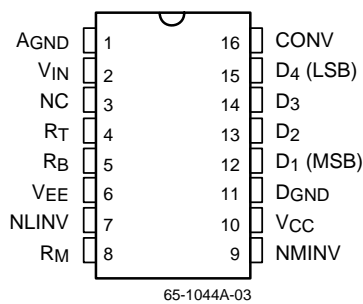

16 Lead DIP

Pin Descriptions

Pin Name	Pin Number		Value	Description
	DIP	PLCC		
Power				
VCC	10	13	+5.0V	Positive Supply Voltage
VEE	6	8	-5.2V	Negative Supply Voltage
DGND	11	14	0.0V	Digital Ground
AGND	1	1	0.0V	Analog Ground
Reference				
RT	4	4	0.0V	Reference Resistor, Top
RM	8	11	-0.5V	Reference Resistor, Middle
RB	5	7	-1.0V	Reference Resistor, Bottom
Control				
NMINV	9	12	TTL	Not MSB Invert
NLINV	7	10	TTL	Not LSB Invert
Convert				
CONV	16	20	TTL	Convert
Analog Input				
VIN	2	2	0V to -1V	Analog Input Signal
Output				
D1	12	15	TTL	MSB Output
D2	13	16	TTL	
D3	14	17	TTL	
D4	15	18	TTL	LSB Output
NC	3	3, 5, 6, 9, 19	AGND	No Connect

Absolute Maximum Ratings

(beyond which the device may be damaged)¹

Type	Parameter	Min	Max	Unit
Supply Voltages	VCC (measured to DGND)	-0.5	7.0	V
	VEE (measured to AGND)	+0.5	-7.0	V
	AGND (measured to DGND)	-0.5	+0.5	V
Input Voltages	CONV, NMINV, NLINV (measured to DGND)	-0.5	+5.5	V
	VIN, VRT, VRB (measured to AGND)	+0.5	VEE	V
	VRT (measured to VRB)	-2.2	+2.2	V
Output	Applied voltage (measured to DGND) ²	-0.5	+5.5	V
	Applied current, externally forced ^{3,4}	-1.0	+6.0	mA
	Short circuit duration (single output in high state to ground)		1	sec
Temperature	Operating, ambient	-55	+125	°C
	Operating, junction		+150	°C
	Lead, soldering (10 seconds)		+300	°C
	Storage	-65	+150	°C

Notes:

1. Absolute maximum ratings are limiting values applied individually while all other parameters are within specified operating conditions. Functional operation under any of these conditions is NOT implied.
2. Applied voltage must be current limited to specified range.
3. Forcing voltage must be limited to specified range.
4. Current is specified as positive when flowing into the device.

Operating Conditions

Parameter		Min.	Nom.	Max.	Units
VCC	Positive Supply Voltage (measured to DGND)	4.75	5.0	5.25	V
VEE	Negative Supply Voltage (measured to AGND)	-4.9	-5.2	-5.5	V
VAGND	Analog Ground Voltage (measured to DGND)	-0.1	0.0	0.1	V
tPWL	CONV Pulse Width, LOW	17			ns
tPWH	CONV Pulse Width, HIGH	17			ns
VIL	Input Voltage, Logic LOW			0.8	V
VIH	Input Voltage, Logic HIGH	2.0			V
IOL	Output Current, Logic LOW			4.0	mA
IOH	Output Current, Logic HIGH			-400	μA
VRT	Most Positive Reference	-1.9	0.0	0.1	V
VRB	Most Negative Reference	-2.1	-1.0	-0.1	V
VRT – VRB	Reference Differential	0.2	1.0	2.0	V
VIN	Input Voltage	VRB		VRT	V
TA	Ambient Temperature, Still Air	0		70	°C

Electrical Characteristics

Within specified operating conditions

Parameter		Test Conditions	Min.	Max.	Units
ICC	Positive Supply Current	VCC = Max, static ¹		15	mA
IEE	Negative Supply Current	VEE = Max, static			
		TA = 0°C to 70°C		-50	mA
		TA = 70°C		-40	mA
IREF	Reference Current	VRT, VRB = Nom		2	mA
RREF	Total Reference Resistance		500		Ohms
RIN	Input Equivalent Resistance	VRT, VRB = Nom, VIN = VRB	250		Kohms
CIN	Input Capacitance			25	pF
ICB	Input Constant Bias Current	VEE = Max		40	μA
IIL	Input Current, Logic LOW	VCC = Max, VI = 0.5V			
		CONV		-0.8	mA
		NMINV, NLINV		-0.8	mA
IiH	Input Current, Logic HIGH	VCC = Max, VI = 2.4V		200	μA
Ii	Input Current, Max Input Voltage	VCC = Max, VI = 5.5V		1.0	mA
VOL	Output Voltage, Logic LOW	VCC = Min, IOL = Max		0.5	V
VOH	Output Voltage, Logic HIGH	VCC = Min, IOH = Max	2.4		V
IOS	Short Circuit Output Current	VCC = Max, One pin to ground, one second duration, Output HIGH		-300	mA
Ci	Digital Input Capacitance	TA = 25°C, F = 1 MHz		15	pF

Note:

1. Worst case: all digital inputs and outputs LOW.

Switching Characteristics

Within specified operating conditions

Parameter		Test Conditions	Min.	Max.	Units
FS	Maximum Conversion Rate	VCC = Min, VEE = Min	25		Msps
tSTO	Sampling Time Offset	VCC = Min, VEE = Min		10	ns
tD	Digital Output Delay	VCC = Min, VEE = Min, Load 1		30	ns
tHO	Digital Output Hold Time	VCC = Max, VEE = Max, Load 1	5		ns

System Performance Characteristics

Within specified operating conditions

Parameter	Test Conditions	Min.	Max.	Units	
ELI	Linearity Error Integral Independent	VRB = Nom		1.6	%
ELD	Linearity Error Differential			1.6	%
CS	Code Size	VRT, VRB = Nom	75	125	% Nominal
EOT	Offset Error Top	VIN = VRT		+30	mV
EOB	Offset Error Bottom	VIN = VRB		+40	mV
Tco	Offset Error Temperature Coefficient			±20	µV/°C
BW	Bandwidth, Full Power Input		12.5		MHz
tTR	Transient Response, Full Scale			10	ns
EAP	Aperture Error			30	ps

Timing Diagram

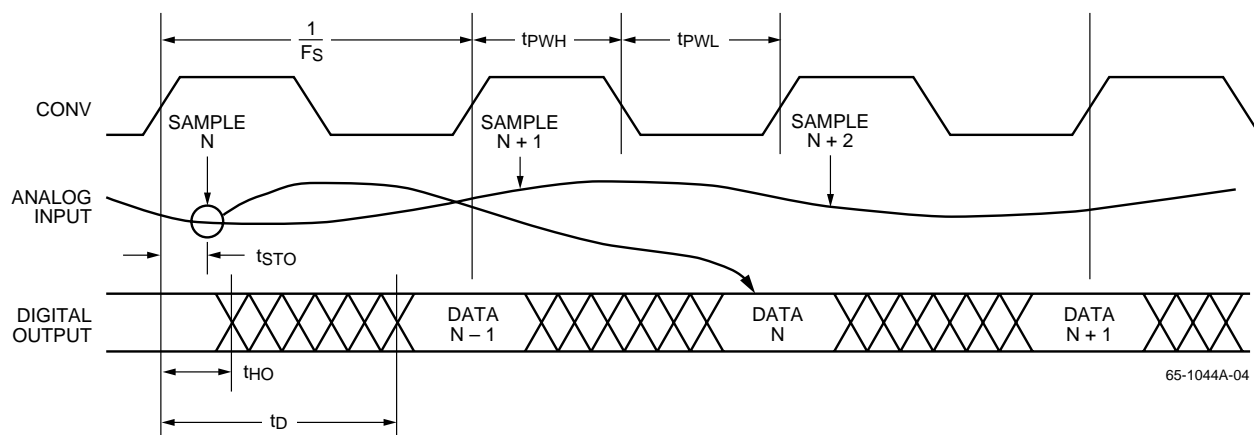

65-1044A-04

Equivalent Circuits

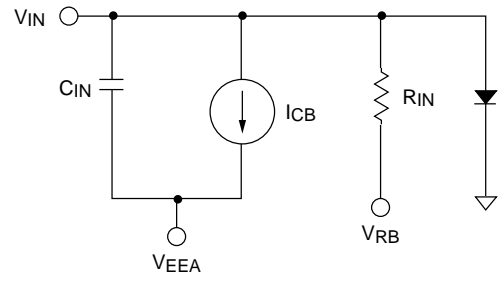
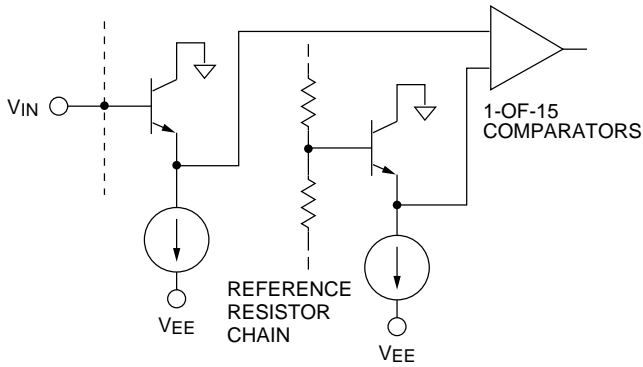

65-1044A-05

Figure 1. Simplified Analog Input Equivalent Circuit

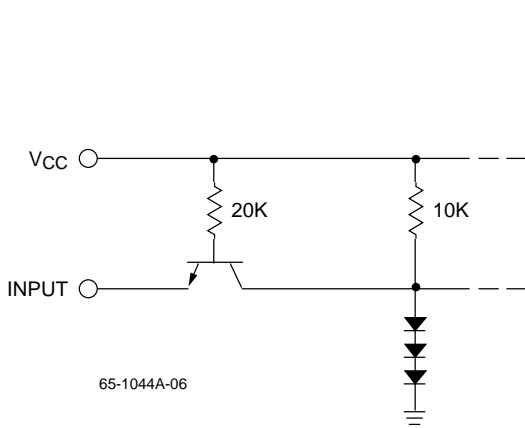

65-1044A-06

Figure 2. Digital Input Equivalent Circuit

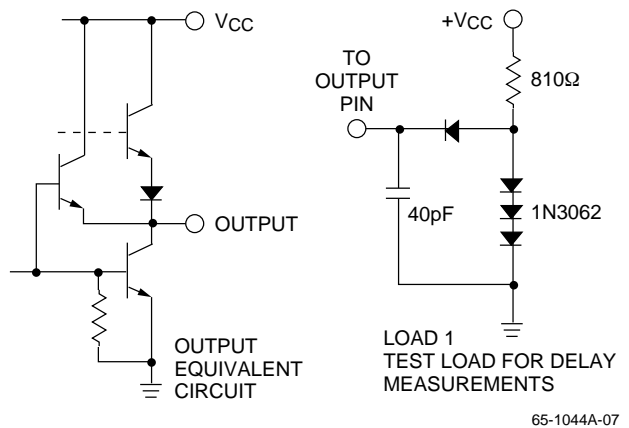

65-1044A-07

Figure 3. Output Circuits

Applications Discussion

Calibration

To calibrate the TDC1044A, adjust V_{RT} and V_{RB} to set the 1st and 15th thresholds to the desired voltages. Assuming a 0V to -1V desired range, continuously strobe the converter with -0.0033V (1/2 LSB from 0.000V) on the analog input, and adjust V_{RT} for output toggling between codes 0000 and 0001. Then apply -0.976V (1/2 LSB from -1.000V) and adjust V_{RB} for toggling between codes 1110 and 1111. Instead of adjusting V_{RT} , R_T can be connected to analog ground and the 0V end of the range calibrated with an amplifier offset control. R_B is a convenient point for gain adjustment that is not in the analog signal path.

Typical Interface Circuit

The TDC1044A does not require a special input buffer amplifier to drive the analog input because of its low input capacitance. A terminated low-impedance transmission line (<100 Ohms) connected to the V_{IN} terminal of the device is sufficient if the input voltage levels match those of the A/D converter.

However, many driver circuits lack sufficient offset control, drive current, or gain stability. The typical interface circuit in Figure 4 shows a simple amplifier and voltage reference circuit that may be used with the device. U2 is a wide-band operational amplifier with a gain factor of -1. As the video

input increases from zero to one volt, V_{IN} of the TDC1044A decreases from zero to -1 volt. With true binary selected ($N_{MINV} = 1$ and $N_{LINV} = 1$), output codes increase from 0000 to 1111.

A small value resistor, R_{12} , serves to isolate the small input capacitance of the A/D converter from the amplifier output and insure frequency stability. Pulse and frequency response of the amplifier are optimized by variable capacitor C12. The reference voltage for the TDC1044A is generated by amplifier U3. System gain is adjusted by varying R_9 , which controls the reference voltage level to the A/D converter.

Input voltage range and input impedance for the circuit are determined by resistors R_1 and R_2 . Formulas for calculating values for these input resistors are:

$$R_1 = \frac{1}{\left(\frac{2V_R}{Z_{IN}}\right) - \frac{1}{1000}}$$

and

$$R_2 = Z_{IN} - \left(\frac{1000 R_1}{1000 + R_1}\right)$$

where V_R is the input voltage range of the circuit, Z_{IN} is the input impedance of the circuit, and the constant 1000 comes from the value of R_3 . As shown, the circuit is set up for 1Vp-p 75 Ohm video input.

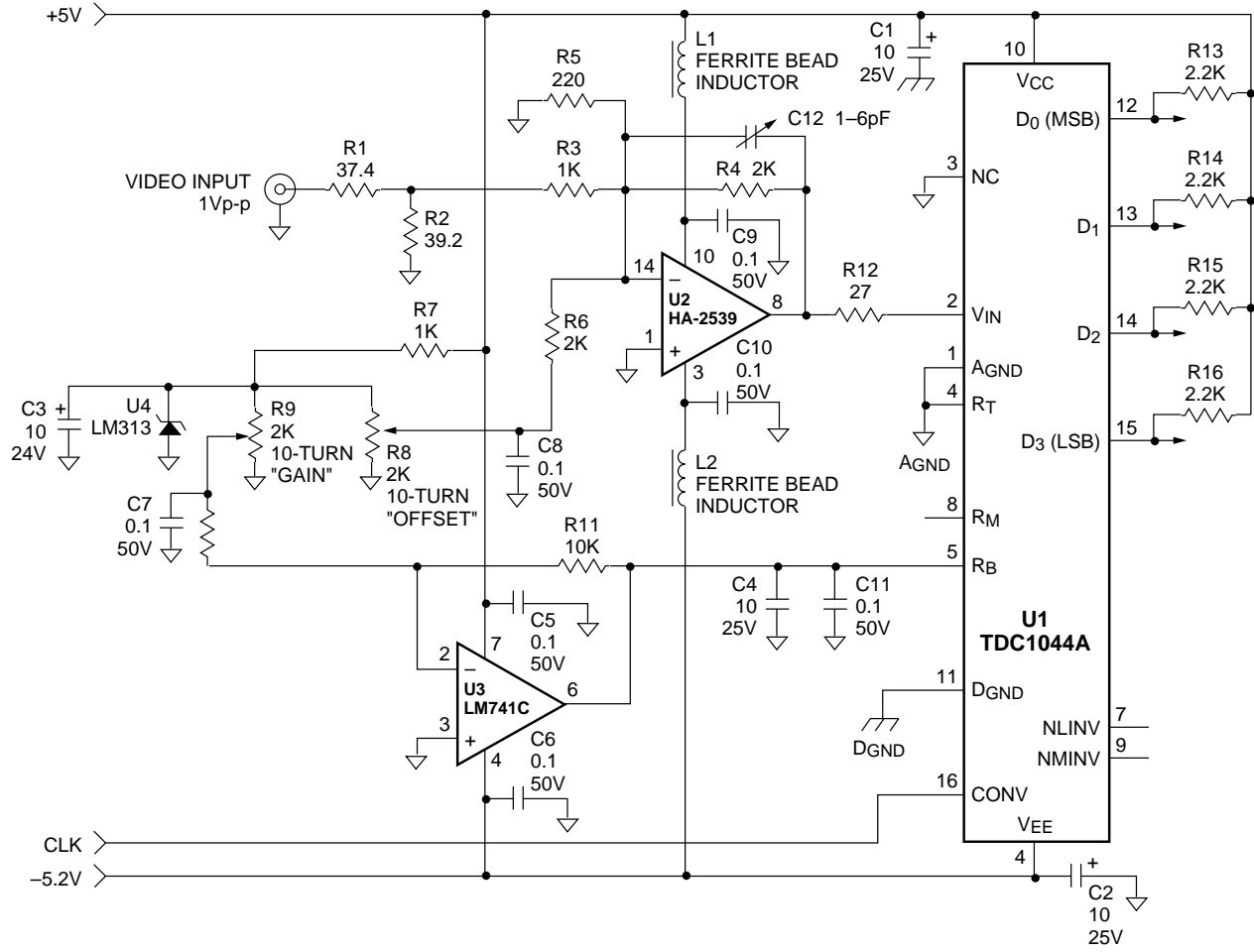

65-1044A-08

Figure 4. Typical Interface Circuit

Notes:

Notes:

Mechanical Dimensions

16-Lead Ceramic DIP Package

Symbol	Inches		Millimeters		Notes
	Min.	Max.	Min.	Max.	
A	—	.200	—	5.08	
b1	.014	.023	.36	.58	8
b2	.050	.065	1.27	1.65	2
c1	.008	.015	.20	.38	8
D	.745	.840	18.92	21.33	4
E	.220	.310	5.59	7.87	4
e	.100 BSC		2.54 BSC		5, 9
eA	.300 BSC		7.62 BSC		7
L	.115	.160	2.92	4.06	
Q	.015	.060	.38	1.52	3
s1	.005	—	.13	—	6
α	90°	105°	90°	105°	

Notes:

1. Index area: a notch or a pin one identification mark shall be located adjacent to pin one. The manufacturer's identification shall not be used as pin one identification mark.
2. The minimum limit for dimension "b2" may be .023 (.58mm) for leads number 1, 8, 9 and 16 only.
3. Dimension "Q" shall be measured from the seating plane to the base plane.
4. This dimension allows for off-center lid, meniscus and glass overrun.
5. The basic pin spacing is .100 (2.54mm) between centerlines. Each pin centerline shall be located within $\pm .010$ (.25mm) of its exact longitudinal position relative to pins 1 and 16.
6. Applies to all four corners (leads number 1, 8, 9, and 16).
7. "eA" shall be measured at the center of the lead bends or at the centerline of the leads when " α " is 90°.
8. All leads – Increase maximum limit by .003 (.08mm) measured at the center of the flat, when lead finish applied.
9. Fourteen spaces.

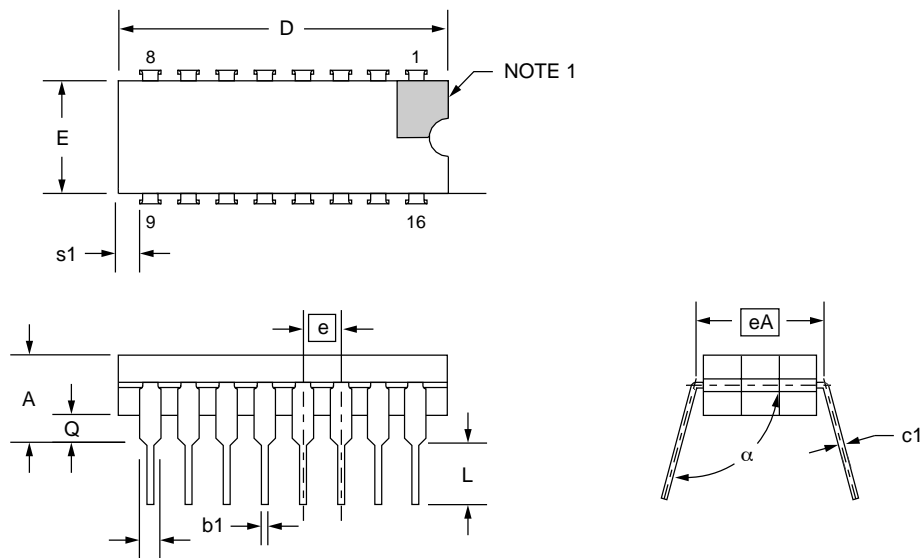

Mechanical Dimensions (continued)

16-Lead Plastic DIP Package

Symbol	Inches		Millimeters		Notes
	Min.	Max.	Min.	Max.	
A	—	.210	—	5.33	
A1	.015	—	.38	—	
A2	.115	.195	2.93	4.95	
B	.014	.022	.36	.56	
B1	.045	.070	1.14	1.78	
C	.008	.015	.20	.38	4
D	.745	.840	18.92	21.33	2
D1	.005	—	.13	—	
E	.300	.325	7.62	8.26	
E1	.240	.280	6.10	7.11	2
e	.100 BSC		2.54 BSC		
eB	—	.430	—	10.92	
L	.115	.160	2.92	4.06	
N	16		16		5

Notes:

1. Dimensioning and tolerancing per ANSI Y14.5M-1982.
2. "D" and "E1" do not include mold flashing. Mold flash or protrusions shall not exceed .010 inch (0.25mm).
3. Terminal numbers are shown for reference only.
4. "C" dimension does not include solder finish thickness.
5. Symbol "N" is the maximum number of terminals.

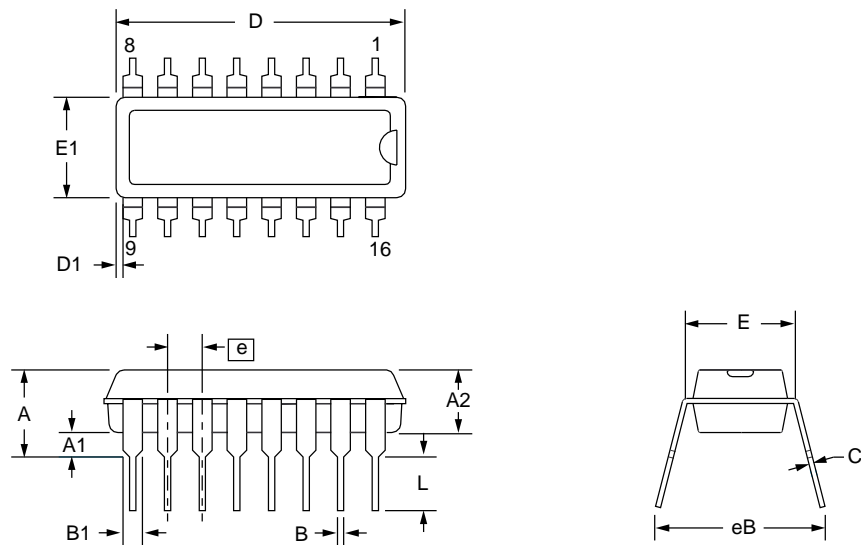

Mechanical Dimensions (continued)

20-Lead PLCC Package

Symbol	Inches		Millimeters		Notes
	Min.	Max.	Min.	Max.	
A	.165	.180	4.19	4.57	
A1	.090	.120	2.29	3.05	
A2	.020	—	.51	—	
B	.013	.021	.33	.53	
B1	.026	.032	.66	.81	
D/E	.385	.395	9.78	10.03	
D1/E1	.350	.356	8.89	9.04	3
D3/E3	.200 BSC		5.08 BSC		
e	.050 BSC		1.27 BSC		
J	.042	.048	1.07	1.22	2
ND/NE	5		5		
N	20		20		
ccc	—	.004	—	0.10	

Notes:

1. All dimensions and tolerances conform to ANSI Y14.5M-1982
2. Corner and edge chamfer (J) = 45°
3. Dimension D1 and E1 do not include mold protrusion. Allowable protrusion is .245" (.101mm)

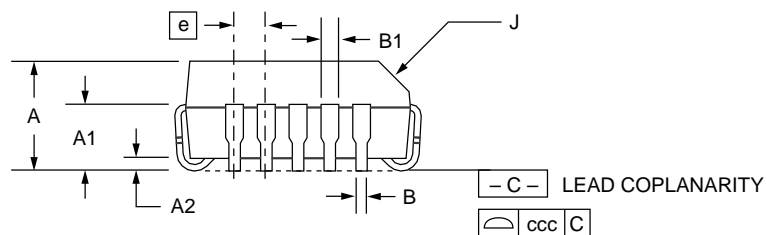
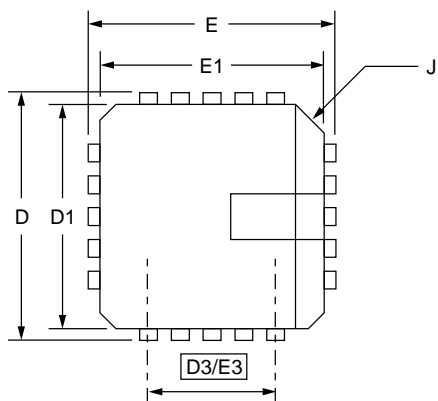

Ordering Information

Product Number	Temperature Range	Screening	Package	Package Marking
TDC1044AB9C	0°C to 70°C	Commercial	16-Lead Ceramic DIP	1044AB9C
TDC1044AN9C	0°C to 70°C	Commercial	16-Lead Plastic DIP	1044AN9C
TDC1044AR4C	0°C to 70°C	Commercial	20-Lead PLCC	1044AR4C

LIFE SUPPORT POLICY

FAIRCHILD'S PRODUCTS ARE NOT AUTHORIZED FOR USE AS CRITICAL COMPONENTS IN LIFE SUPPORT DEVICES OR SYSTEMS WITHOUT THE EXPRESS WRITTEN APPROVAL OF THE PRESIDENT OF FAIRCHILD SEMICONDUCTOR CORPORATION. As used herein:

1. Life support devices or systems are devices or systems which, (a) are intended for surgical implant into the body, or (b) support or sustain life, and (c) whose failure to perform when properly used in accordance with instructions for use provided in the labeling, can be reasonably expected to result in a significant injury of the user.
2. A critical component in any component of a life support device or system whose failure to perform can be reasonably expected to cause the failure of the life support device or system, or to affect its safety or effectiveness.