

TV VERTICAL DEFLECTION BOOSTER

- POWER AMPLIFIER
- FLYBACK GENERATOR
- THERMAL PROTECTION

DESCRIPTION

Designed for monitors and high performance TVs, the TDA8179S vertical deflection booster delivers flyback voltages up to 90V.

The TDA8179S operates with supplies up to 42V and provides up to 2A_{app} output current to drive to yoke.

The TDA8179S is offered in HEPTAWATT package.

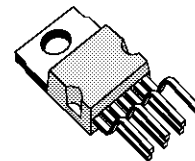

HEPTAWATT
(Plastic Package)

ORDER CODE : TDA8179S

PIN CONNECTIONS

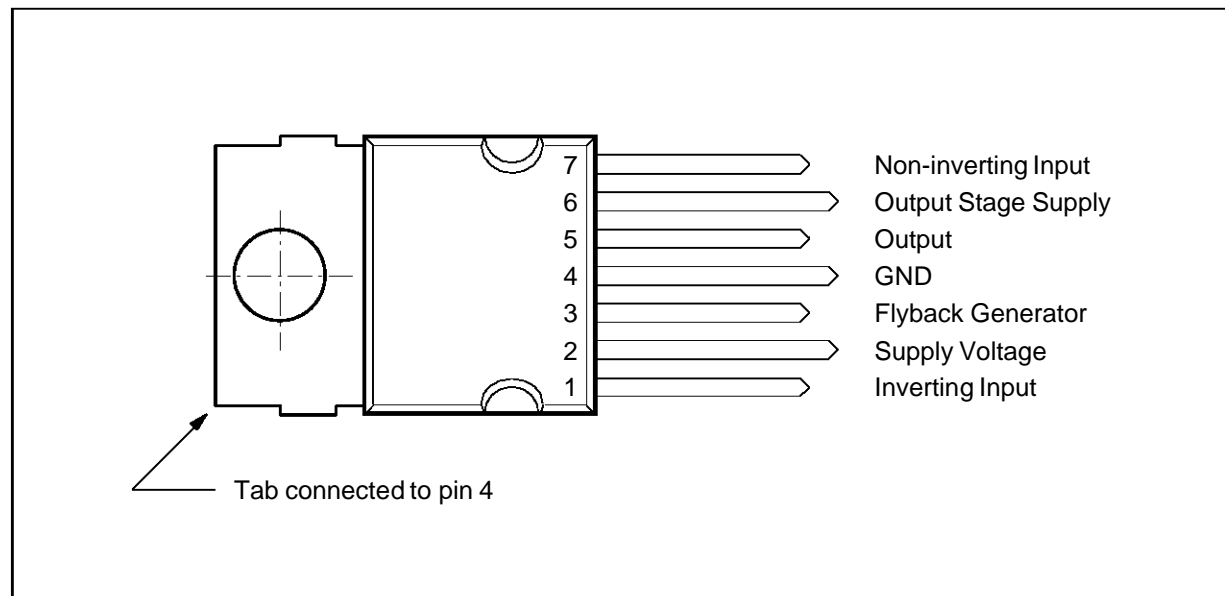

8179S-01.EPS

TDA8179S

BLOCK DIAGRAM

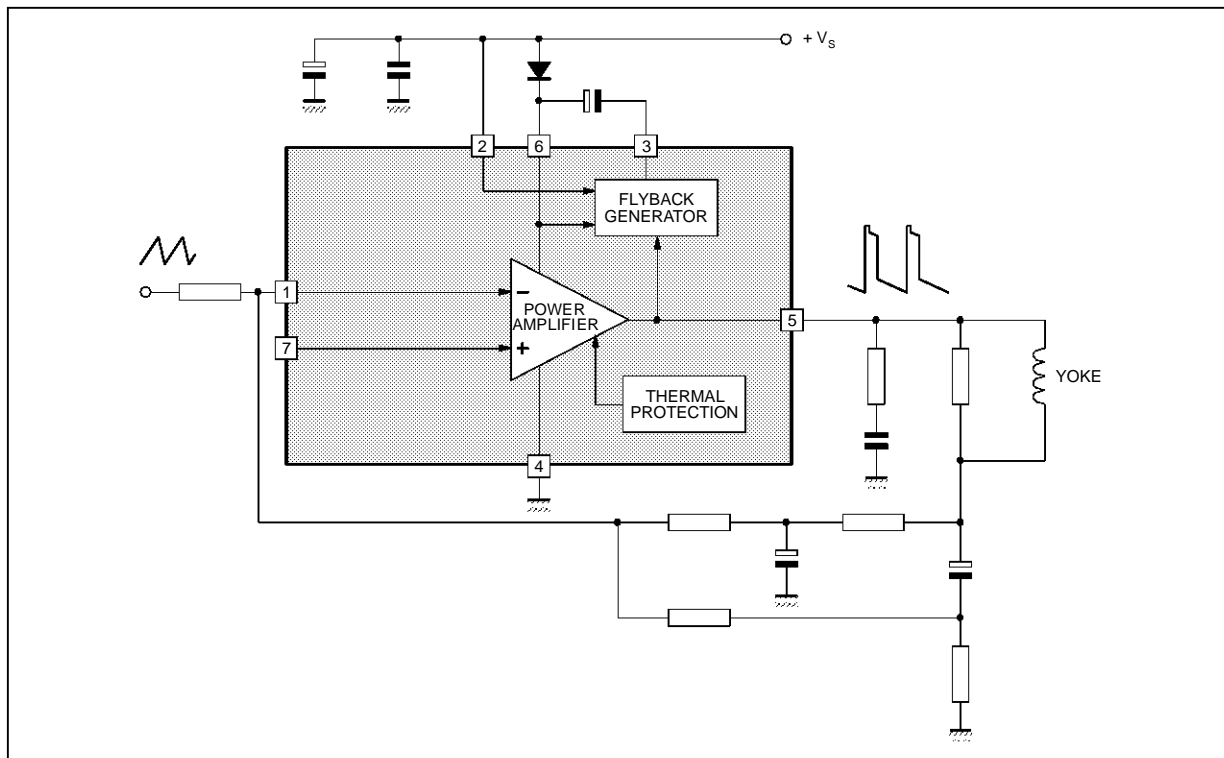

8179S-02.EPS

APPLICATION CIRCUIT

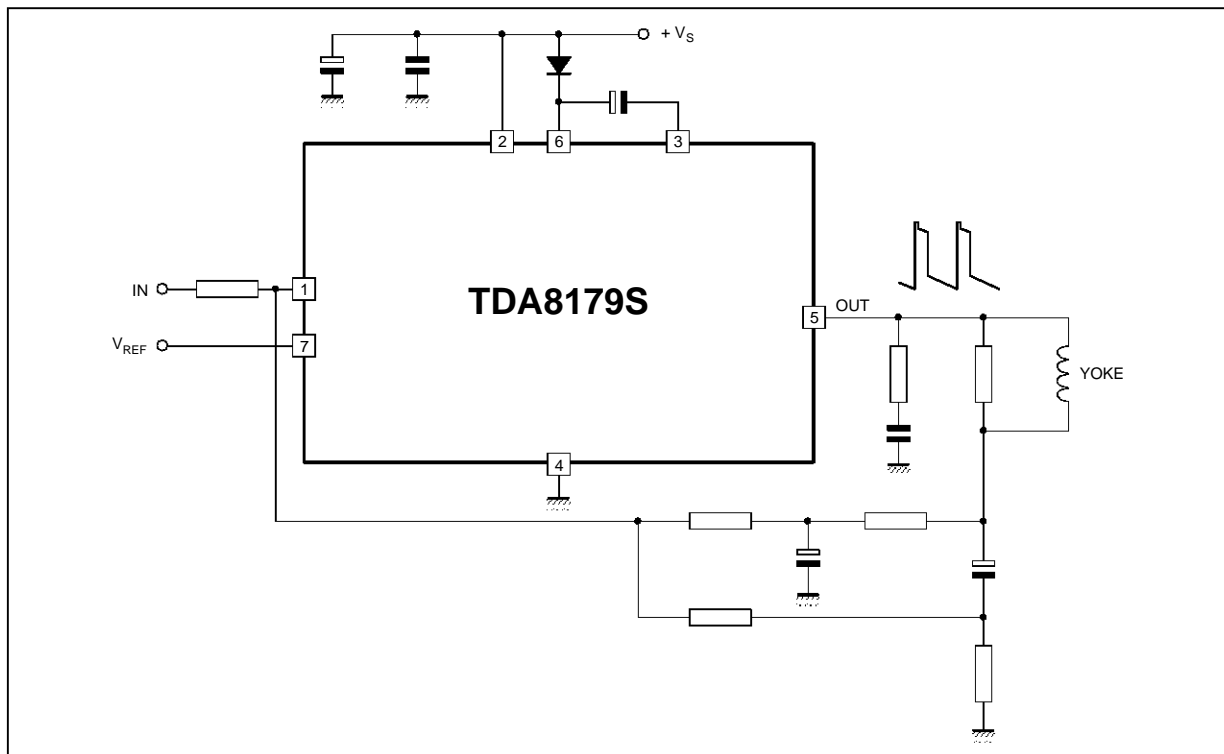

8179S-03.EPS

Note : For values see "Easy Design of Vertical Deflection Stages" (software available from our sales offices)

ABSOLUTE MAXIMUM RATINGS

Symbol	Parameter	Value	Unit
V _S	Supply Voltage (pin 2)	50	V
V ₅ , V ₆	Flyback Peak Voltage	100	V
V ₁ , V ₇	Amplifier Input Voltage	+ V _S	
I _O	Output Peak Current	2 2 1.8	A
	Non-repetitive, t = 2ms f = 50 or 60Hz, t ≤ 10μs f = 50 or 60Hz, t > 10μs		
I ₃	Pin 3 DC at V ₅ < V ₂ Pin 3 Peak Flyback Current at f = 50 or 60Hz, t _{fly} ≤ 1.5ms	100 1.8	mA A
P _{tot}	Total Power Dissipation at T _C = 70°C	20	W
T _{stg}	Storage Temperature	- 40, + 150	°C
T _j	Junction Temperature	0, +150	°C

8179S-01.TBL

THERMAL DATA

Symbol	Parameter	Value	Unit
R _{th(j-c)}	Junction-case Thermal Resistance	Max. 3	°C/W

8179S-02.TBL

ELECTRICAL CHARACTERISTICS

(V₇ = 2.2V, V_S = 42V, T_A = 25°C, unless otherwise specified)

(refer to the test circuits - see Figure 1 next page)

Symbol	Parameter	Test Conditions	Min.	Typ.	Max.	Unit
V _S	Operating Supply Voltage Range		10		42	V
I ₂	Pin 2 Quiescent Current	I ₃ = 0 I ₅ = 0		10	20	mA
I ₆	Pin 6 Quiescent Current	I ₃ = 0 I ₅ = 0		20	40	mA
I ₁	Amplifier Bias Current	V ₁ = 1V		- 0.2	- 1	μA
V _{3L}	Scanning Voltage	I ₃ = 20mA		1.3	1.8	V
V ₅	Quiescent Output Voltage	V _S = 42V R _a = 3.9kΩ V _S = 35V R _a = 5.6kΩ	23.4 17	24.2 17.8	25 18.5	V
V _{5L}	Output Saturation Voltage to GND	I ₅ = 1A		1.2	1.5	V
V _{5H}	Output Saturation Voltage to Supply	- I ₅ = 1A		2.2	2.6	V
V _{D5-6}	Diode Forward Voltage between Pins 5-6	I _D = 1A		1.5	3	V
V _{D3-2}	Diode Forward Voltage between Pins 3-2	I _D = 1A		1.5	3	V
R ₁	Input Resistance			200		kΩ
T _j	Junction Temperature for Thermal Shutdown			140		°C

8179S-03.TBL

TDA8179S

FIGURE 1 : DC Test Circuits

Figure 1a : Measurement of I_1 , I_2 , I_6

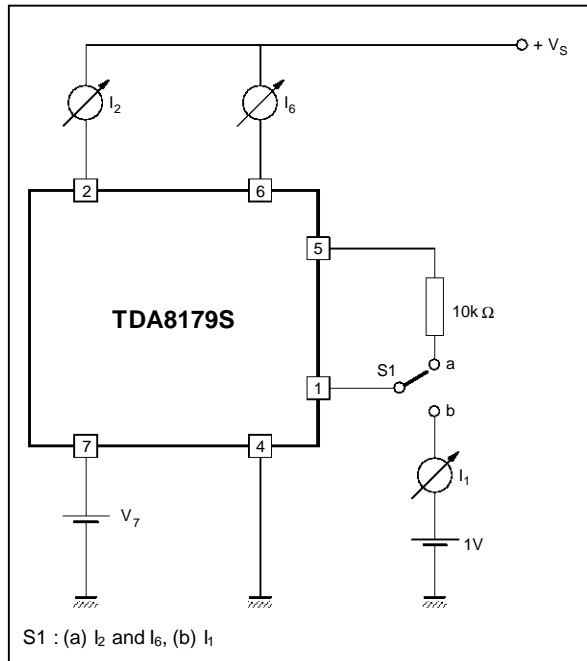

Figure 1b : Measurement of V_{5H}

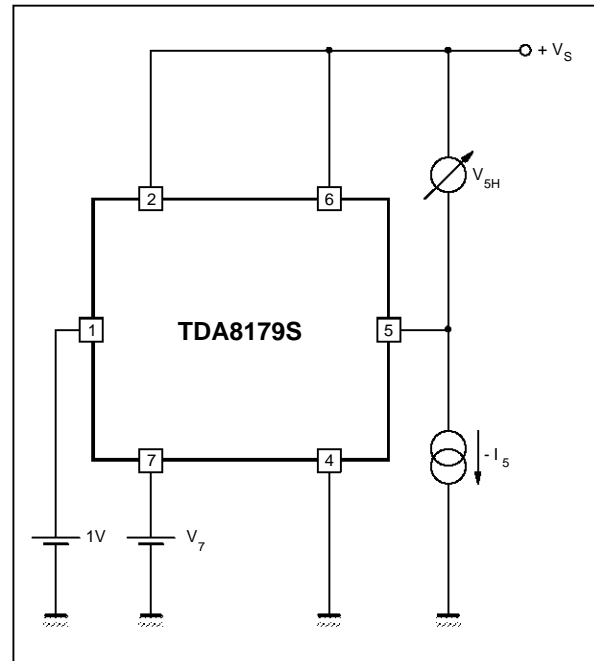

Figure 1c : Measurement of V_{3L} , V_{5L}

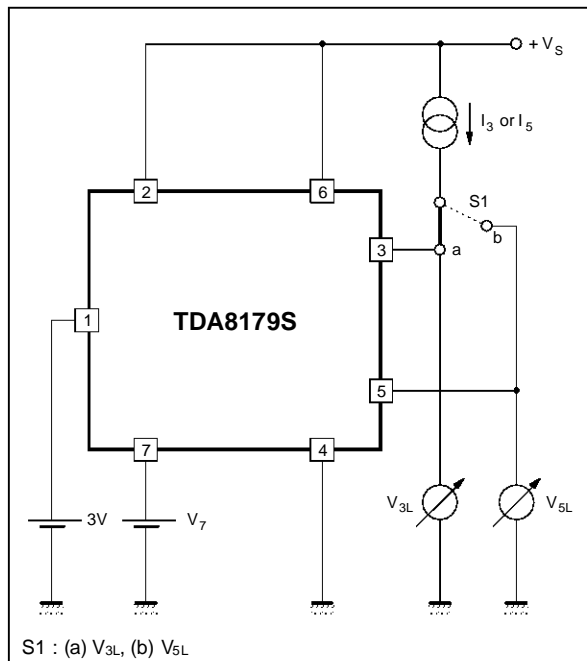

Figure 1d : Measurement of V_5

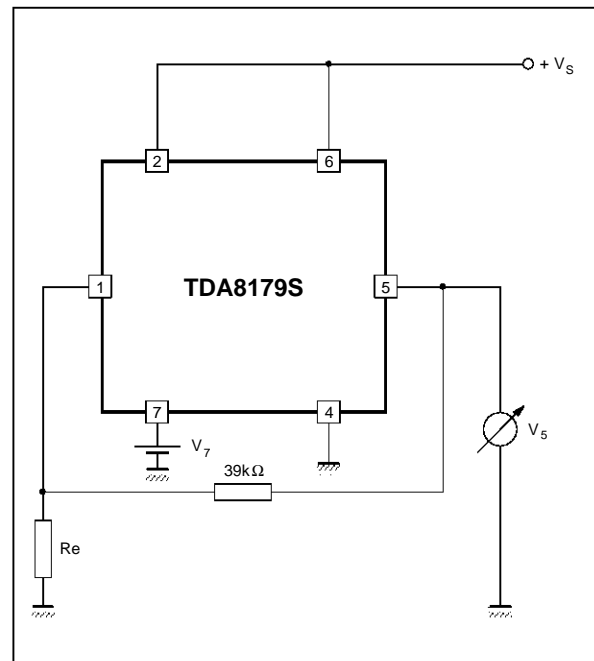
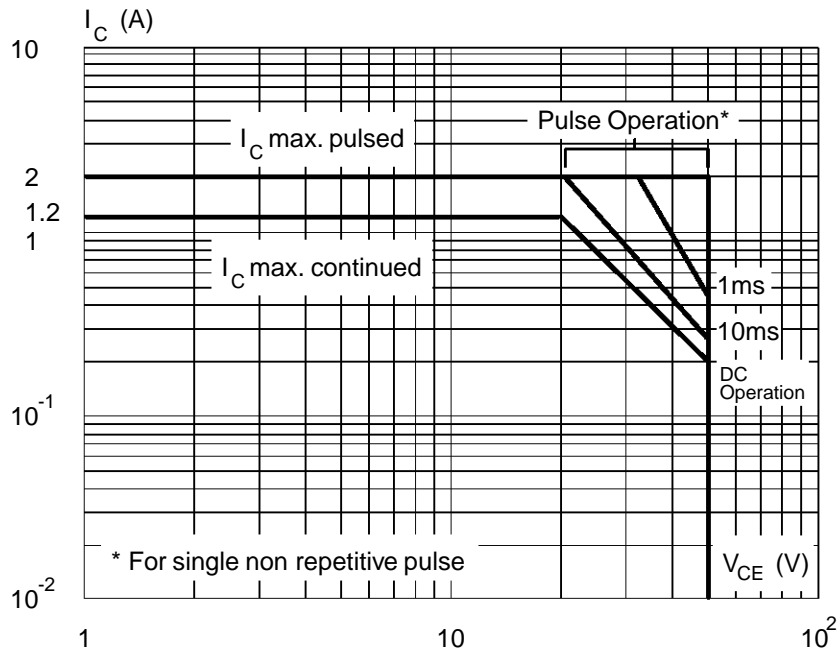

Figure 2 : SOA of Each Output Power Transistor at $T_A = 25^\circ\text{C}$



8179S-08.EPS

