

# DATA SHEET

**TDA6107JF**

Triple video output amplifier

Product specification

2002 Oct 18

## Triple video output amplifier

## TDA6107JF

### FEATURES

- Typical bandwidth of 5.5 MHz for an output signal of 60 V (p-p)
- High slew rate of 900 V/μs
- No external components required
- Very simple application
- Single supply voltage of 200 V
- Internal reference voltage of 2.5 V
- Fixed gain of 50
- Black-Current Stabilization (BCS) circuit with voltage window from 1.8 to 6 V and current window from -100 μA to 10 mA
- Thermal protection
- Internal protection against positive flashover discharges appearing on the CRT.

### GENERAL DESCRIPTION

The TDA6107JF includes three video output amplifiers and is intended to drive the three cathodes of a colour CRT directly. The device is contained in a plastic DIL-bent-SIL 9-pin medium power (DBS9MPF) package, and uses high-voltage DMOS technology.

To obtain maximum performance, the amplifier should be used with black-current control.

### ORDERING INFORMATION

| TYPE NUMBER | PACKAGE |   |          |
|-------------|---------|---|----------|
|             | NAME    | DESCRIPTION   | VERSION  |
| TDA6107JF   | DBS9MPF | plastic DIL-bent-SIL medium power package with fin; 9 leads | SOT111-1 |

Triple video output amplifier

TDA6107JF

BLOCK DIAGRAM

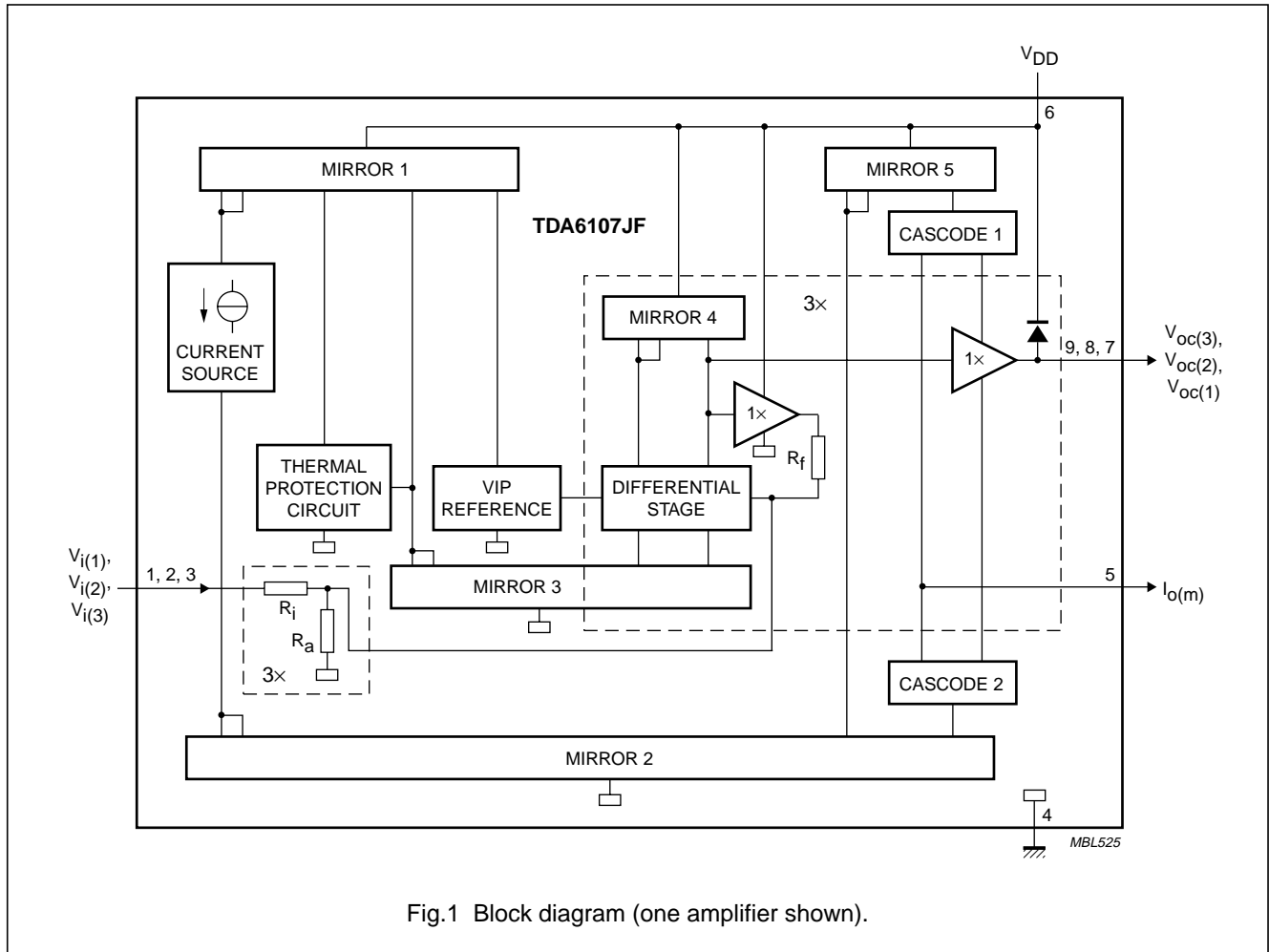

Fig.1 Block diagram (one amplifier shown).

PINNING

| SYMBOL      | PIN | DESCRIPTION                      |
|-------------|-----|----------------------------------|
| $V_{i(1)}$  | 1   | inverting input 1                |
| $V_{i(2)}$  | 2   | inverting input 2                |
| $V_{i(3)}$  | 3   | inverting input 3                |
| GND         | 4   | ground (fin)                     |
| $I_{om}$    | 5   | black-current measurement output |
| $V_{DD}$    | 6   | supply voltage                   |
| $V_{oc(3)}$ | 7   | cathode output 3                 |
| $V_{oc(2)}$ | 8   | cathode output 2                 |
| $V_{oc(1)}$ | 9   | cathode output 1                 |

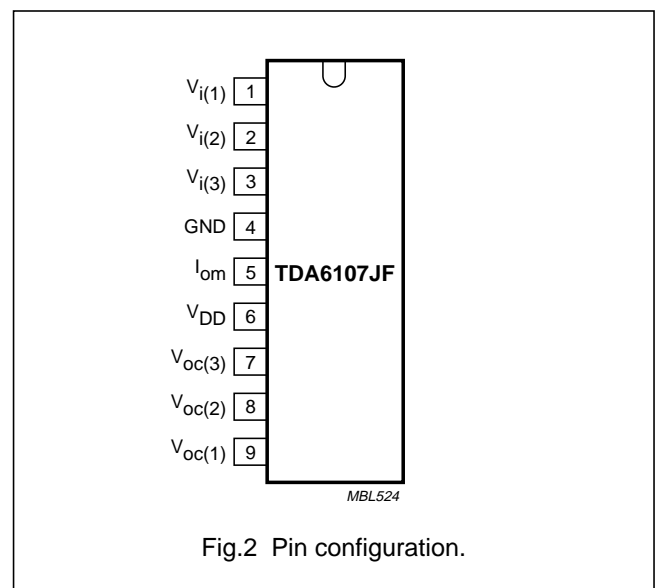

Fig.2 Pin configuration.

## Triple video output amplifier

TDA6107JF

**LIMITING VALUES**

In accordance with the Absolute Maximum Rating System (IEC 60134); voltages measured with respect to pin 4 (ground); currents as specified in Fig.1; unless otherwise specified.

| SYMBOL        | PARAMETER  | MIN. | MAX.     | UNIT         |
|---------------|--|------|----------|--------------|
| $V_{DD}$      | supply voltage   | 0    | 250      | V            |
| $V_i$         | input voltage at pins 1 to 3   | 0    | 12       | V            |
| $V_{o(m)}$    | measurement output voltage   | 0    | 6        | V            |
| $V_{oc}$      | cathode output voltage   | 0    | $V_{DD}$ | V            |
| $I_{ocsm(L)}$ | LOW non-repetitive peak cathode output current at a flashover discharge of 100 $\mu$ C | 0    | 3        | A            |
| $I_{ocsm(H)}$ | HIGH non-repetitive peak cathode output current at a flashover discharge of 100 nC     | 0    | 6        | A            |
| $T_{stg}$     | storage temperature  | -55  | +150     | $^{\circ}$ C |
| $T_j$         | junction temperature   | -20  | +150     | $^{\circ}$ C |
| $V_{es}$      | electrostatic handling voltage   |      |          |              |
|               | Human Body Model (HBM)   | -    | 3000     | V            |
|               | Machine Model (MM)   | -    | 300      | V            |

**HANDLING**

Inputs and outputs are protected against electrostatic discharge in normal handling. However, to be totally safe, it is desirable to take normal precautions appropriate to handling MOS devices (see "Handling MOS Devices").

**QUALITY SPECIFICATION**

Quality specification "SNW-FQ-611 part D" is applicable and can be found in the "Quality reference Handbook". The handbook can be ordered using the code 9397 750 00192.

Triple video output amplifier

TDA6107JF

**THERMAL CHARACTERISTICS**

| SYMBOL          | PARAMETER                                   | CONDITIONS | VALUE | UNIT |
|-----------------|---|------------|-------|------|
| $R_{th(j-a)}$   | thermal resistance from junction to ambient |            | 56    | K/W  |
| $R_{th(j-fin)}$ | thermal resistance from junction to fin     | note 1     | 11    | K/W  |
| $R_{th(h-a)}$   | thermal resistance from heatsink to ambient |            | 18    | K/W  |

**Note**

1. An external heatsink is necessary.

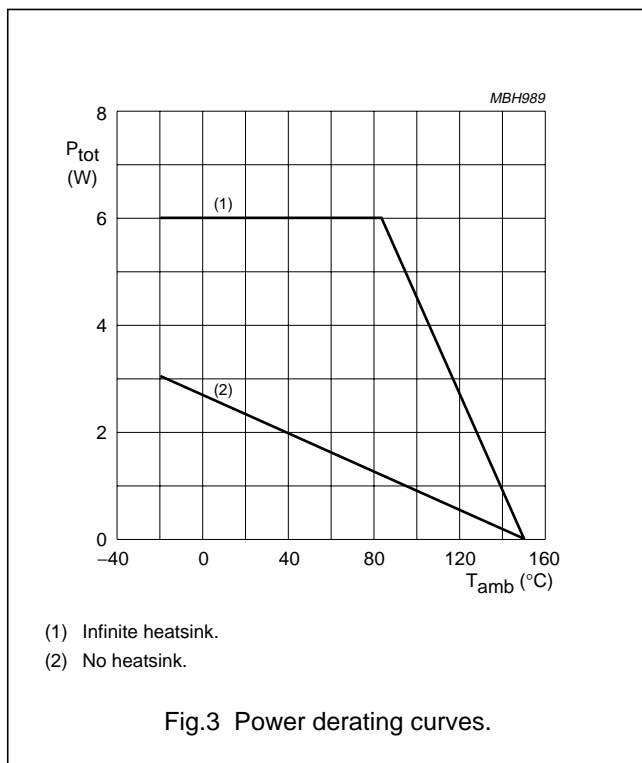

**Thermal protection**

The internal thermal protection circuit gives a decrease of the slew rate at high temperatures: 10% decrease at 130 °C and 30% decrease at 145 °C (typical values on the spot of the thermal protection circuit).

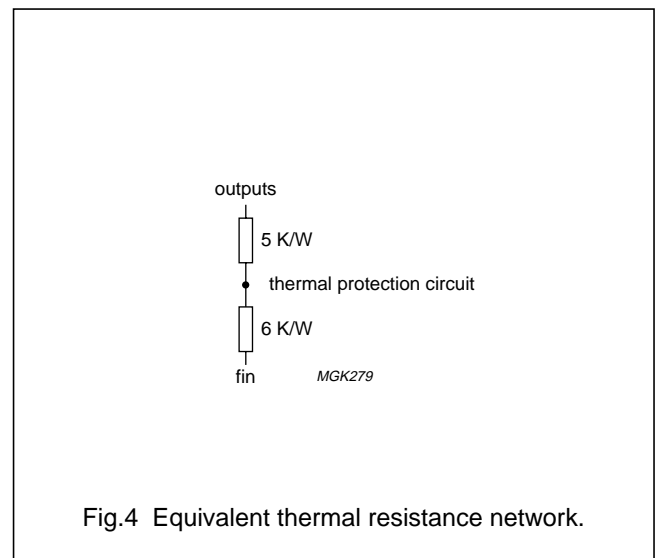

## Triple video output amplifier

## TDA6107JF

**CHARACTERISTICS**

Operating range:  $T_j = -20$  to  $+150$  °C;  $V_{DD} = 180$  to  $210$  V. Test conditions:  $T_{amb} = 25$  °C;  $V_{DD} = 200$  V;

$V_{o(c1)} = V_{o(c2)} = V_{o(c3)} = \frac{1}{2}V_{DD}$ ;  $C_L = 10$  pF ( $C_L$  consists of parasitic and cathode capacitance);  $R_{th(h-a)} = 18$  K/W (measured in test circuit of Fig.8); unless otherwise specified.

| SYMBOL                            | PARAMETER   | CONDITIONS   | MIN.          | TYP. | MAX. | UNIT       |
|-----------------------------------|---|--|---------------|------|------|------------|
| $I_q$                             | quiescent supply current  |  | 5.6           | 6.6  | 7.6  | mA         |
| $V_{ref(int)}$                    | internal reference voltage (input stage)  |  | –             | 2.5  | –    | V          |
| $R_i$                             | input resistance  |  | –             | 3.6  | –    | k $\Omega$ |
| G                                 | gain of amplifier   |  | 47.5          | 51.0 | 55.0 |            |
| $\Delta G$                        | gain difference   |  | –2.5          | 0    | +2.5 |            |
| $V_{O(oc)}$                       | nominal output voltage at pins 7, 8 and 9 (DC value)  | $I_i = 0$ $\mu$ A  | 116           | 129  | 142  | V          |
| $\Delta V_{O(oc)(offset)}$        | differential nominal output offset voltage between pins 7 and 8, 8 and 9 and 9 and 7 (DC value) | $I_i = 0$ $\mu$ A  | –             | 0    | 5    | V          |
| $\Delta V_{o(c)(T)}$              | output voltage temperature drift at pins 7, 8 and 9   |  | –             | 10   | –    | mV/K       |
| $\Delta V_{o(c)(T)(offset)}$      | differential output offset voltage temperature drift between pins 7 and 8, 8 and 9 and 7 and 9  |  | –             | 0    | –    | mV/K       |
| $I_{o(m)(offset)}$                | offset current of measurement output (for three channels)                                       | $I_{o(c)} = 0$ $\mu$ A;<br>$1.5$ V < $V_i$ < $5.5$ V;<br>$1.8$ V < $V_{o(m)}$ < $6$ V                            | –50           | –    | +50  | $\mu$ A    |
| $\Delta I_{o(m)}/\Delta I_{o(c)}$ | linearity of current transfer (for three channels)  | $-100$ $\mu$ A < $I_{o(c)}$ < $100$ $\mu$ A;<br>$1.5$ V < $V_i$ < $5.5$ V;<br>$1.8$ V < $V_{o(m)}$ < $6$ V       | –0.9          | –1.0 | –1.1 |            |
|                                   |   | $-100$ $\mu$ A $\leq I_{o(c)} < 10$ mA;<br>$1.5$ V < $V_i$ < $5.5$ V;<br>$1.8$ V < $V_{o(m)}$ < $4$ V            | –0.9          | –1.0 | –1.1 |            |
| $I_{o(c)(max)}$                   | maximum peak output current (pins 7, 8 and 9)   | $50$ V < $V_{o(c)} < V_{DD} - 50$ V  | –             | 20   | –    | mA         |
| $V_{o(c)(min)}$                   | minimum output voltage (pins 7, 8 and 9)  | $V_i = 7.0$ V; at $I_{o(c)} = 0$ mA;<br>note 1   | –             | –    | 10   | V          |
| $V_{o(c)(max)}$                   | maximum output voltage (pins 7, 8 and 9)  | $V_i = 1.0$ V; at $I_{o(c)} = 0$ mA;<br>note 1   | $V_{DD} - 15$ | –    | –    | V          |
| $B_S$                             | small signal bandwidth (pins 7, 8 and 9)  | $V_{o(c)} = 60$ V (p-p)  | –             | 5.5  | –    | MHz        |
| $B_L$                             | large signal bandwidth (pins 7, 8 and 9)  | $V_{o(c)} = 100$ V (p-p)   | –             | 4.5  | –    | MHz        |
| $t_{PCO}$                         | cathode output propagation time 50% input to 50% output (pins 7, 8 and 9)                       | $V_{o(c)} = 100$ V (p-p) square wave; $f < 1$ MHz;<br>$t_r = t_f = 40$ ns (pins 1, 2 and 3);<br>see Figs 6 and 7 | –             | 60   | –    | ns         |

## Triple video output amplifier

## TDA6107JF

| SYMBOL            | PARAMETER   | CONDITIONS   | MIN. | TYP. | MAX. | UNIT       |
|-------------------|---|--|------|------|------|------------|
| $\Delta t_{PCO}$  | difference in cathode output propagation time 50% input to 50% output (pins 7 and 8, 7 and 9 and 8 and 9) | $V_{O(c)} = 100$ V (p-p) square wave; $f < 1$ MHz; $t_r = t_f = 40$ ns (pins 1, 2 and 3)                   | -10  | 0    | +10  | ns         |
| $t_{o(r)}$        | cathode output rise time 10% output to 90% output (pins 7, 8 and 9)                                       | $V_{O(c)} = 50$ to 150 V square wave; $f < 1$ MHz; $t_f = 40$ ns (pins 1, 2 and 3); see Fig.6              | 67   | 91   | 113  | ns         |
| $t_{o(f)}$        | cathode output fall time 90% output to 10% output (pins 7, 8 and 9)                                       | $V_{O(c)} = 150$ to 50 V square wave; $f < 1$ MHz; $t_r = 40$ ns (pins 1, 2 and 3); see Fig.7              | 67   | 91   | 113  | ns         |
| $t_{st}$          | settling time 50% input to 99% < output < 101% (pins 7, 8 and 9)  | $V_{O(c)} = 100$ V (p-p) square wave; $f < 1$ MHz; $t_r = t_f = 40$ ns (pins 1, 2 and 3); see Figs 6 and 7 | –    | –    | 350  | ns         |
| SR                | slew rate between 50 V to ( $V_{DD} - 50$ V) (pins 7, 8 and 9)  | $V_i = 4$ V (p-p) square wave; $f < 1$ MHz; $t_r = t_f = 40$ ns (pins 1, 2 and 3)                          | –    | 900  | –    | V/ $\mu$ s |
| $O_v$             | cathode output voltage overshoot (pins 7, 8 and 9)  | $V_{O(c)} = 100$ V (p-p) square wave; $f < 1$ MHz; $t_r = t_f = 40$ ns (pins 1, 2 and 3); see Figs 6 and 7 | –    | 2    | –    | %          |
| PSRR              | power supply rejection ratio  | $f < 50$ kHz; note 2   | –    | 55   | –    | dB         |
| $\alpha_{ct(DC)}$ | DC crosstalk between channels   |  | –    | -50  | –    | dB         |

**Notes**

1. See also Fig.5 for the typical DC-to-DC transfer of  $V_i$  to  $V_{O(oc)}$ .
2. The ratio of the change in supply voltage to the change in input voltage when there is no change in output voltage.

Triple video output amplifier

TDA6107JF

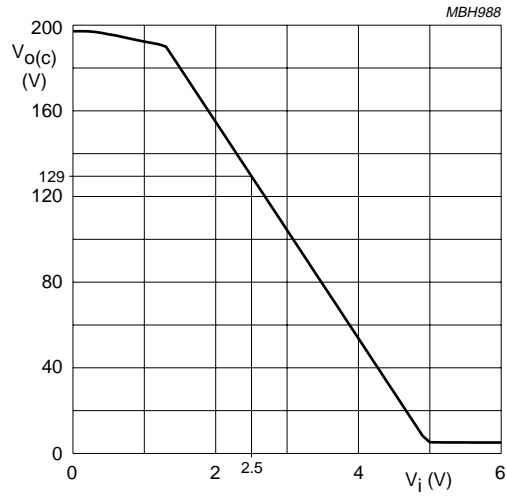

Fig.5 Typical DC-to-DC transfer of  $V_i$  to  $V_{oc}$ .

Triple video output amplifier

TDA6107JF

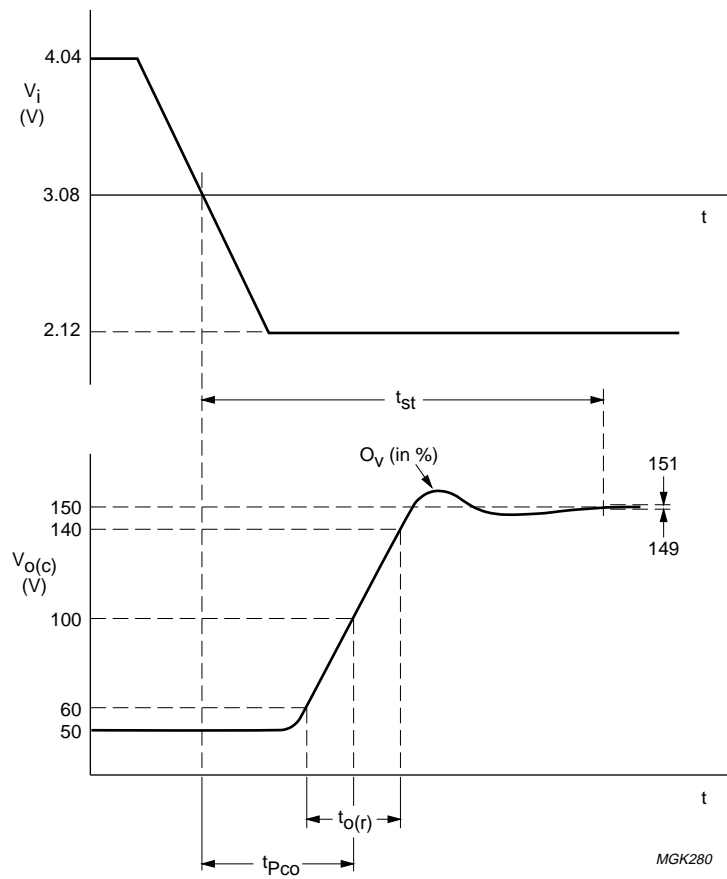

Fig.6 Output voltage (pins 7, 8 and 9) rising edge as a function of the AC input signal.

Triple video output amplifier

TDA6107JF

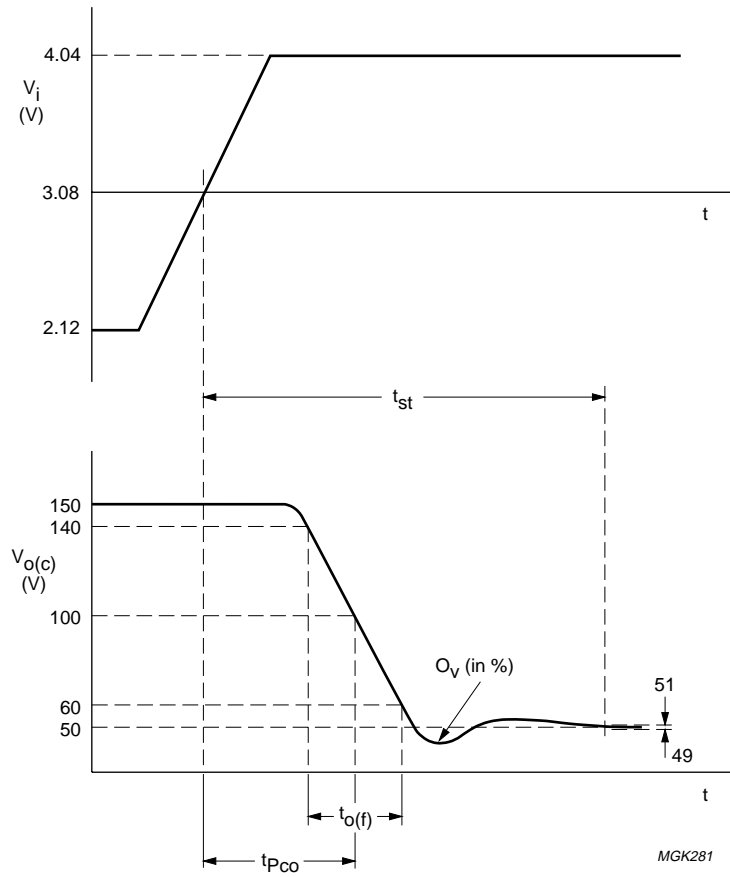

Fig.7 Output voltage (pins 7, 8 and 9) falling edge as a function of the AC input signal.

## Triple video output amplifier

TDA6107JF

### Cathode output

The cathode output is protected against peak current (caused by positive voltage peaks during high-resistance flash) of 3 A maximum with a charge content of 100  $\mu\text{C}$  <sup>(1)</sup>.

The cathode is also protected against peak currents (caused by positive voltage peaks during low-resistance flash) of 6 A maximum with a charge content of 100 nC <sup>(1)</sup>.

The DC voltage of  $V_{\text{DD}}$  (pin 6) must be within the operating range of 180 to 210 V during the peak currents.

### Flashover protection

The TDA6107JF incorporates protection diodes against CRT flashover discharges that clamp the cathodes output voltage up to a maximum of  $V_{\text{DD}} + V_{\text{diode}}$ .

To limit the diode current an external 1.5 k $\Omega$  carbon high-voltage resistor in series with the cathode output and a 2 kV spark gap are needed (for this resistor value, the CRT has to be connected to the main PCB <sup>(1)</sup>).

$V_{\text{DD}}$  must be decoupled to GND:

1. With a capacitor >20 nF with good HF behaviour (e.g. foil); this capacitor must be placed as close as possible to pins 6 and 4, but definitely within 5 mm.
2. With a capacitor >3.3  $\mu\text{F}$  on the picture tube base print, depending on the CRT size.

### Switch-off behaviour

The switch-off behaviour of the TDA6107JF is controllable. This is because the output pins of the TDA6107JF are still under control of the input pins for low power supply voltages (approximately 30 V and higher).

### Bandwidth

The addition of the flash resistor produces a decreased bandwidth and increases the rise and fall times; see "Application Note AN96072".

<sup>(1)</sup>External protection against higher currents is described in "Application Note AN96072".

### Dissipation

Regarding dissipation, distinction must first be made between static dissipation (independent of frequency) and dynamic dissipation (proportional to frequency).

The static dissipation of the TDA6107JF is due to voltage supply currents and load currents in the feedback network and CRT.

The static dissipation  $P_{\text{stat}}$  equals:

$$P_{\text{stat}} = V_{\text{DD}} \times I_{\text{DD}} + 3 \times V_{\text{OC}} \times I_{\text{OC}}$$

Where:

$V_{\text{DD}}$  = supply voltage

$I_{\text{DD}}$  = supply current

$V_{\text{OC}}$  = DC value of cathode voltage

$I_{\text{OC}}$  = DC value of cathode current.

The dynamic dissipation  $P_{\text{dyn}}$  equals:

$$P_{\text{dyn}} = 3 \times V_{\text{DD}} \times (C_{\text{L}} + C_{\text{int}}) \times f_{\text{i}} \times V_{\text{oc(p-p)}} \times \delta$$

Where:

$C_{\text{L}}$  = load capacitance

$C_{\text{int}}$  = internal load capacitance ( $\approx 4$  pF)

$f_{\text{i}}$  = input frequency

$V_{\text{oc(p-p)}}$  = output voltage (peak-to-peak value)

$\delta$  = non-blanking duty cycle.

The IC must be mounted on the picture tube base print to minimize the load capacitance  $C_{\text{L}}$ .

Triple video output amplifier

TDA6107JF

TEST AND APPLICATION INFORMATION

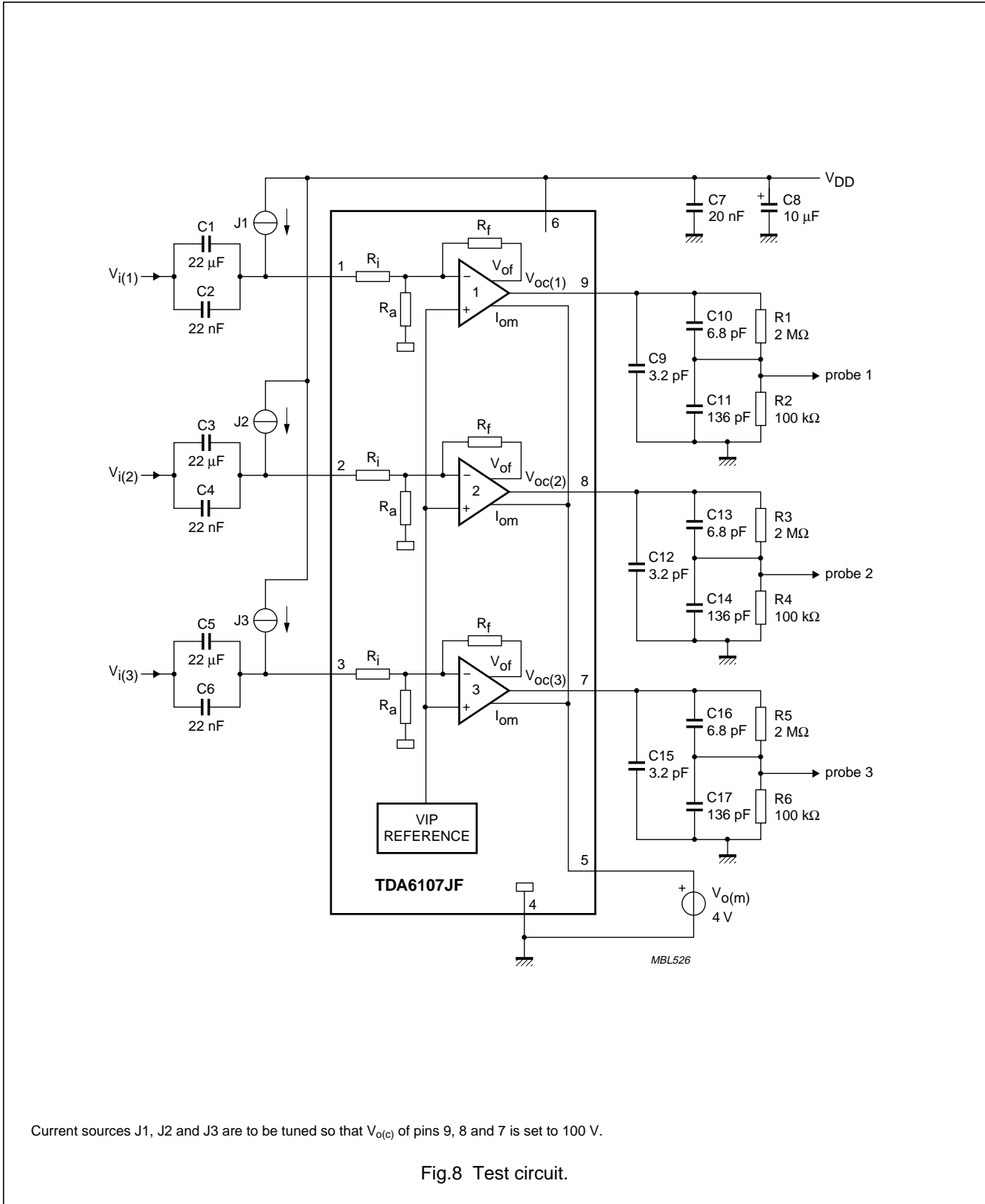

Triple video output amplifier

TDA6107JF

INTERNAL CIRCUITRY

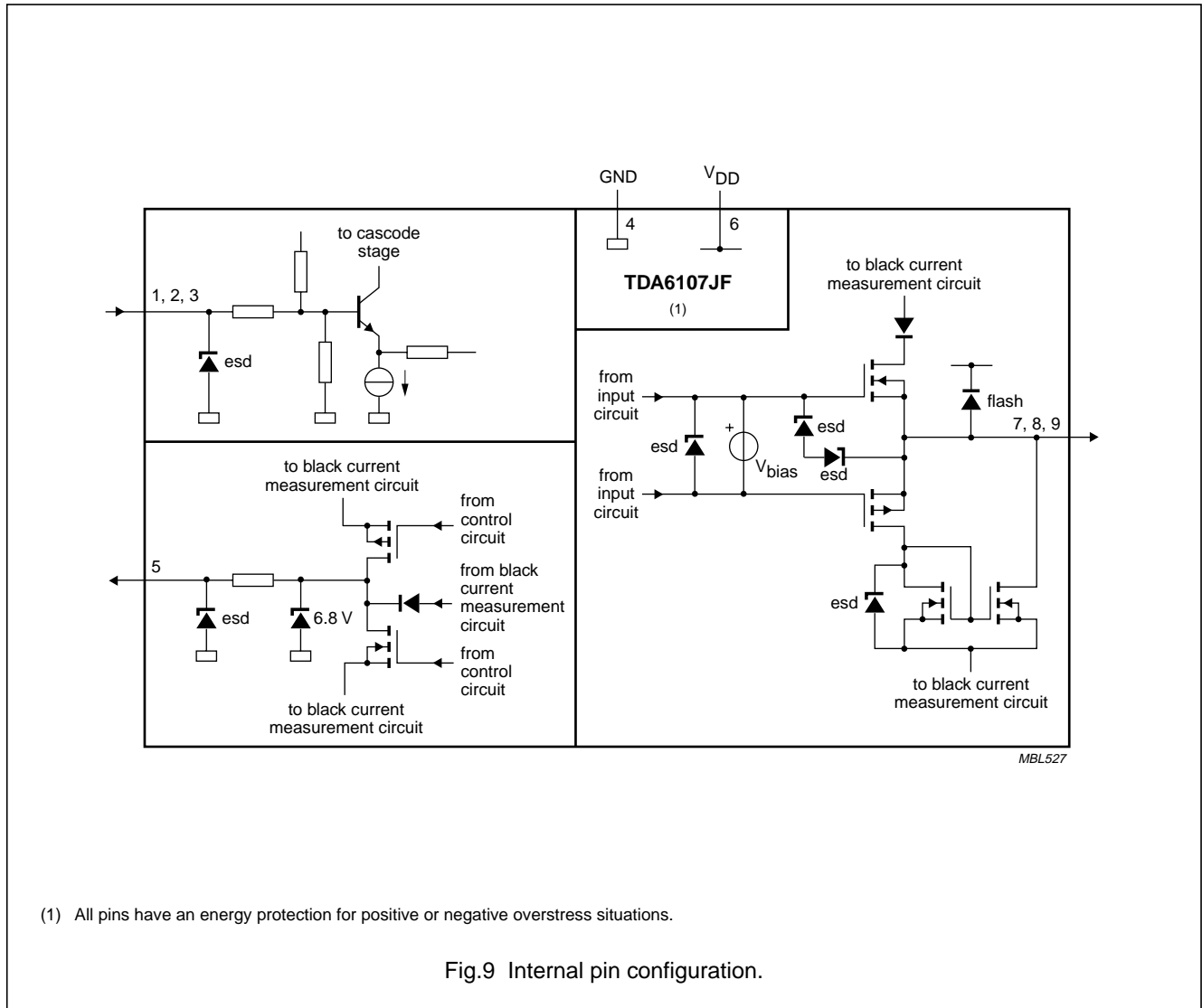

Triple video output amplifier

TDA6107JF

PACKAGE OUTLINE

DBS9MPF: plastic DIL-bent-SIL medium power package with fin; 9 leads

SOT111-1

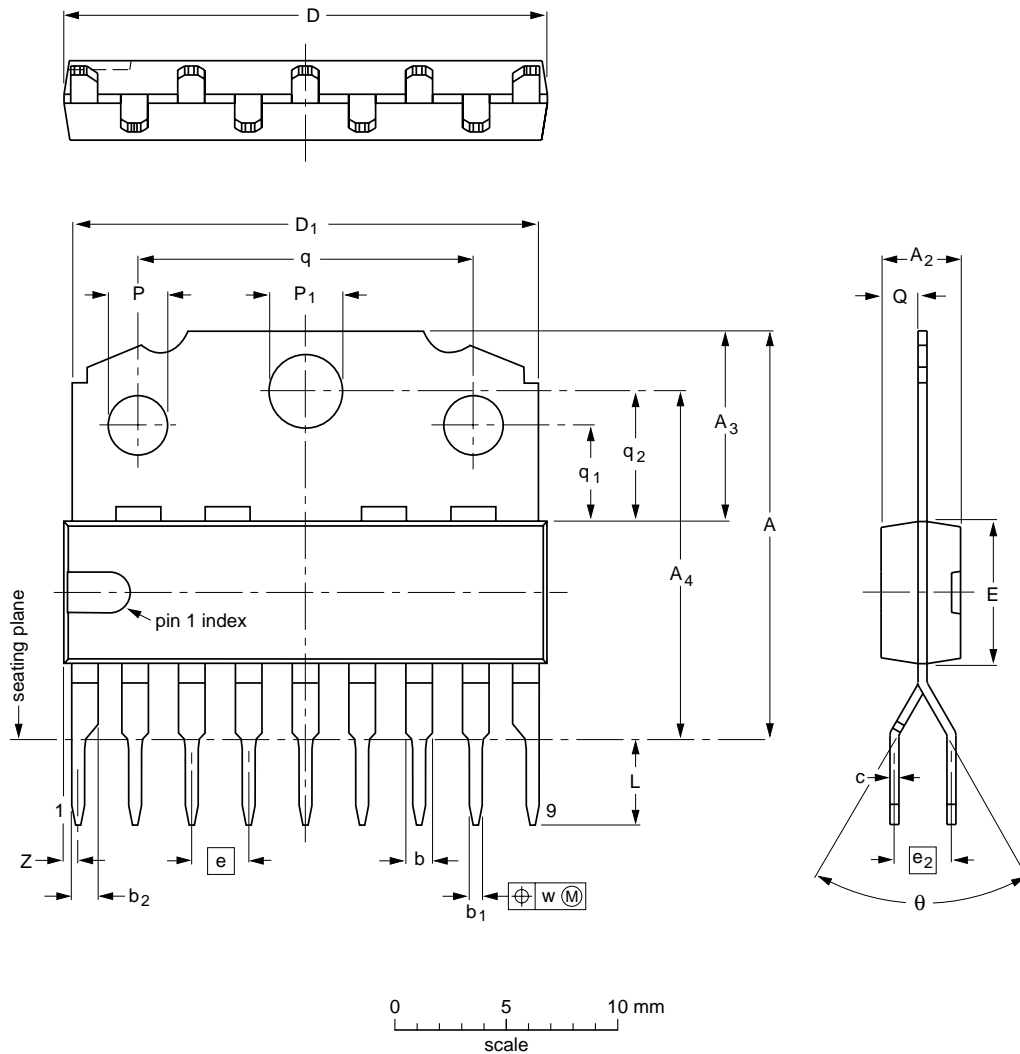

DIMENSIONS (mm are the original dimensions)

| UNIT | A            | A <sub>2</sub> max. | A <sub>3</sub> | A <sub>4</sub> | b            | b <sub>1</sub> | b <sub>2</sub> | c            | D <sup>(1)</sup> | D <sub>1</sub> | E <sup>(1)</sup> | e    | e <sub>2</sub> | L          | P            | P <sub>1</sub> | Q            | q            | q <sub>1</sub> | q <sub>2</sub> | w    | Z <sup>(1)</sup> max. | θ          |
|------|--------------|---------------------|----------------|----------------|--------------|----------------|----------------|--------------|------------------|----------------|------------------|------|----------------|------------|--------------|----------------|--------------|--------------|----------------|----------------|------|-----------------------|------------|
| mm   | 18.5<br>17.8 | 3.7                 | 8.7<br>8.0     | 15.5<br>15.1   | 1.40<br>1.14 | 0.67<br>0.50   | 1.40<br>1.14   | 0.48<br>0.38 | 21.8<br>21.4     | 21.4<br>20.7   | 6.48<br>6.20     | 2.54 | 2.54           | 3.9<br>3.4 | 2.75<br>2.50 | 3.4<br>3.2     | 1.75<br>1.55 | 15.1<br>14.9 | 4.4<br>4.2     | 5.9<br>5.7     | 0.25 | 1.0                   | 65°<br>55° |

Note

1. Plastic or metal protrusions of 0.25 mm maximum per side are not included.

| OUTLINE VERSION | REFERENCES |       |      |  | EUROPEAN PROJECTION | ISSUE DATE           |
|-----------------|------------|-------|------|--|---------------------|----------------------|
|                 | IEC        | JEDEC | EIAJ |  |                     |                      |
| SOT111-1        |            |       |      |  |                     | 92-11-17<br>95-03-11 |

## Triple video output amplifier

## TDA6107JF

**SOLDERING****Introduction to soldering through-hole mount packages**

This text gives a brief insight to wave, dip and manual soldering. A more in-depth account of soldering ICs can be found in our *"Data Handbook IC26; Integrated Circuit Packages"* (document order number 9398 652 90011).

Wave soldering is the preferred method for mounting of through-hole mount IC packages on a printed-circuit board.

**Soldering by dipping or by solder wave**

The maximum permissible temperature of the solder is 260 °C; solder at this temperature must not be in contact with the joints for more than 5 seconds.

The total contact time of successive solder waves must not exceed 5 seconds.

The device may be mounted up to the seating plane, but the temperature of the plastic body must not exceed the specified maximum storage temperature ( $T_{stg(max)}$ ). If the printed-circuit board has been pre-heated, forced cooling may be necessary immediately after soldering to keep the temperature within the permissible limit.

**Manual soldering**

Apply the soldering iron (24 V or less) to the lead(s) of the package, either below the seating plane or not more than 2 mm above it. If the temperature of the soldering iron bit is less than 300 °C it may remain in contact for up to 10 seconds. If the bit temperature is between 300 and 400 °C, contact may be up to 5 seconds.

**Suitability of through-hole mount IC packages for dipping and wave soldering methods**

| PACKAGE                   | SOLDERING METHOD |                         |
|---------------------------|------------------|-------------------------|
|                           | DIPPING          | WAVE                    |
| DBS, DIP, HDIP, SDIP, SIL | suitable         | suitable <sup>(1)</sup> |

**Note**

- For SDIP packages, the longitudinal axis must be parallel to the transport direction of the printed-circuit board.

## Triple video output amplifier

TDA6107JF

## DATA SHEET STATUS

| LEVEL | DATA SHEET STATUS <sup>(1)</sup> | PRODUCT STATUS <sup>(2)(3)</sup> | DEFINITION   |
|-------|----------------------------------|----------------------------------|--|
| I     | Objective data                   | Development                      | This data sheet contains data from the objective specification for product development. Philips Semiconductors reserves the right to change the specification in any manner without notice.  |
| II    | Preliminary data                 | Qualification                    | This data sheet contains data from the preliminary specification. Supplementary data will be published at a later date. Philips Semiconductors reserves the right to change the specification without notice, in order to improve the design and supply the best possible product.             |
| III   | Product data                     | Production                       | This data sheet contains data from the product specification. Philips Semiconductors reserves the right to make changes at any time in order to improve the design, manufacturing and supply. Relevant changes will be communicated via a Customer Product/Process Change Notification (CPCN). |

## Notes

1. Please consult the most recently issued data sheet before initiating or completing a design.
2. The product status of the device(s) described in this data sheet may have changed since this data sheet was published. The latest information is available on the Internet at URL <http://www.semiconductors.philips.com>.
3. For data sheets describing multiple type numbers, the highest-level product status determines the data sheet status.

## DEFINITIONS

**Short-form specification** — The data in a short-form specification is extracted from a full data sheet with the same type number and title. For detailed information see the relevant data sheet or data handbook.

**Limiting values definition** — Limiting values given are in accordance with the Absolute Maximum Rating System (IEC 60134). Stress above one or more of the limiting values may cause permanent damage to the device. These are stress ratings only and operation of the device at these or at any other conditions above those given in the Characteristics sections of the specification is not implied. Exposure to limiting values for extended periods may affect device reliability.

**Application information** — Applications that are described herein for any of these products are for illustrative purposes only. Philips Semiconductors make no representation or warranty that such applications will be suitable for the specified use without further testing or modification.

## DISCLAIMERS

**Life support applications** — These products are not designed for use in life support appliances, devices, or systems where malfunction of these products can reasonably be expected to result in personal injury. Philips Semiconductors customers using or selling these products for use in such applications do so at their own risk and agree to fully indemnify Philips Semiconductors for any damages resulting from such application.

**Right to make changes** — Philips Semiconductors reserves the right to make changes in the products - including circuits, standard cells, and/or software - described or contained herein in order to improve design and/or performance. When the product is in full production (status 'Production'), relevant changes will be communicated via a Customer Product/Process Change Notification (CPCN). Philips Semiconductors assumes no responsibility or liability for the use of any of these products, conveys no licence or title under any patent, copyright, or mask work right to these products, and makes no representations or warranties that these products are free from patent, copyright, or mask work right infringement, unless otherwise specified.

Triple video output amplifier

TDA6107JF

---

**NOTES**

Triple video output amplifier

TDA6107JF

---

**NOTES**

Triple video output amplifier

TDA6107JF

---

**NOTES**

# ***Philips Semiconductors – a worldwide company***

## **Contact information**

For additional information please visit <http://www.semiconductors.philips.com>. Fax: +31 40 27 24825

For sales offices addresses send e-mail to: [sales.addresses@www.semiconductors.philips.com](mailto:sales.addresses@www.semiconductors.philips.com).

© Koninklijke Philips Electronics N.V. 2002

SCA74

All rights are reserved. Reproduction in whole or in part is prohibited without the prior written consent of the copyright owner.

The information presented in this document does not form part of any quotation or contract, is believed to be accurate and reliable and may be changed without notice. No liability will be accepted by the publisher for any consequence of its use. Publication thereof does not convey nor imply any license under patent- or other industrial or intellectual property rights.

Printed in The Netherlands

753504/02/pp20

Date of release: 2002 Oct 18

Document order number: 9397 750 10545

*Let's make things better.*

**Philips  
Semiconductors**



**PHILIPS**

Copyright © Each Manufacturing Company.

All Datasheets cannot be modified without permission.

This datasheet has been download from :

[www.AllDataSheet.com](http://www.AllDataSheet.com)

100% Free DataSheet Search Site.

Free Download.

No Register.

Fast Search System.

[www.AllDataSheet.com](http://www.AllDataSheet.com)