

DATA SHEET

TDA1562Q 70 W high efficiency power amplifier with diagnostic facility

Preliminary specification
File under Integrated Circuits, IC01

1998 Apr 07

70 W high efficiency power amplifier with diagnostic facility

TDA1562Q

FEATURES

- Very high output power, operating from a single low supply voltage
- Low power dissipation, when used for music signals
- Switches to low output power at too high case temperatures
- Few external components
- Fixed gain
- Differential inputs with high common mode rejection
- Mode select pin (on, mute and standby)
- Status I/O pin (class-H, class-B and fast mute)
- All switching levels with hysteresis
- Diagnostic pin with information about:
 - Dynamic Distortion Detector (DDD)
 - Any short-circuit at outputs
 - Open load detector
 - Temperature protection.
- No switch-on or switch-off plops

- Fast mute on supply voltage drops
- Quick start option (e.g. car-telephony/navigation)
- Low (delta) offset voltage at the outputs
- Load dump protection
- Short-circuit safe to ground, supply voltage and across the load
- Low power dissipation in any short-circuit condition
- Protected against electrostatic discharge
- Thermally protected
- Flexible leads.

GENERAL DESCRIPTION

The TDA1562Q is a monolithic integrated 70 W/4 Ω Bridge-Tied Load (BTL) class-H high efficiency power amplifier in a 17-lead DIL-bent-SIL plastic power package.

The device can be used for car audio systems (e.g. car, radio and boosters) as well as mains fed applications (e.g. midi/mini audio combinations and TV sound).

QUICK REFERENCE DATA

Test conditions: $V_P = 14.4$ V; $R_L = 4$ Ω ; $R_s = 0$ Ω ; $f = 1$ kHz; $T_{amb} = 25$ $^{\circ}$ C; unless otherwise specified.

SYMBOL	PARAMETER	CONDITIONS	MIN.	TYP.	MAX.	UNIT
V_P	supply voltage	operating	8	14.4	18	V
		non-operating	–	–	30	V
		load dump	–	–	45	V
$I_{q(tot)}$	total quiescent current	on and mute; $R_L =$ open circuit	–	110	150	mA
I_{stb}	standby current	standby	–	1	50	μ A
$ V_{OO} $	output offset voltage	on and mute	–	–	100	mV
$ \Delta V_{OO} $	delta output offset voltage	on \leftrightarrow mute	–	–	30	mV
G_v	voltage gain		25	26	27	dB
$ Z_{i(dif)} $	differential input impedance		90	150	–	k Ω
P_o	output power	THD = 0.5%	45	55	–	W
		THD = 10%	60	70	–	W
THD	total harmonic distortion	$P_o = 1$ W	–	0.03	–	%
		$P_o = 20$ W	–	0.06	–	%
		DDD active	–	10	–	%
SVRR	supply voltage ripple rejection	on and mute	60	70	–	dB
CMRR	common mode rejection ratio	on	70	80	–	dB
ISRR	input signal rejection ratio	mute	80	90	–	dB
$V_{n(o)}$	noise output voltage	on	–	100	150	μ V

70 W high efficiency power amplifier with diagnostic facility

TDA1562Q

ORDERING INFORMATION

TYPE NUMBER	PACKAGE		
	NAME	DESCRIPTION	VERSION
TDA1562Q	DBS17P	plastic DIL-bent-SIL power package; 17 leads (lead length 12 mm)	SOT243-1

BLOCK DIAGRAM

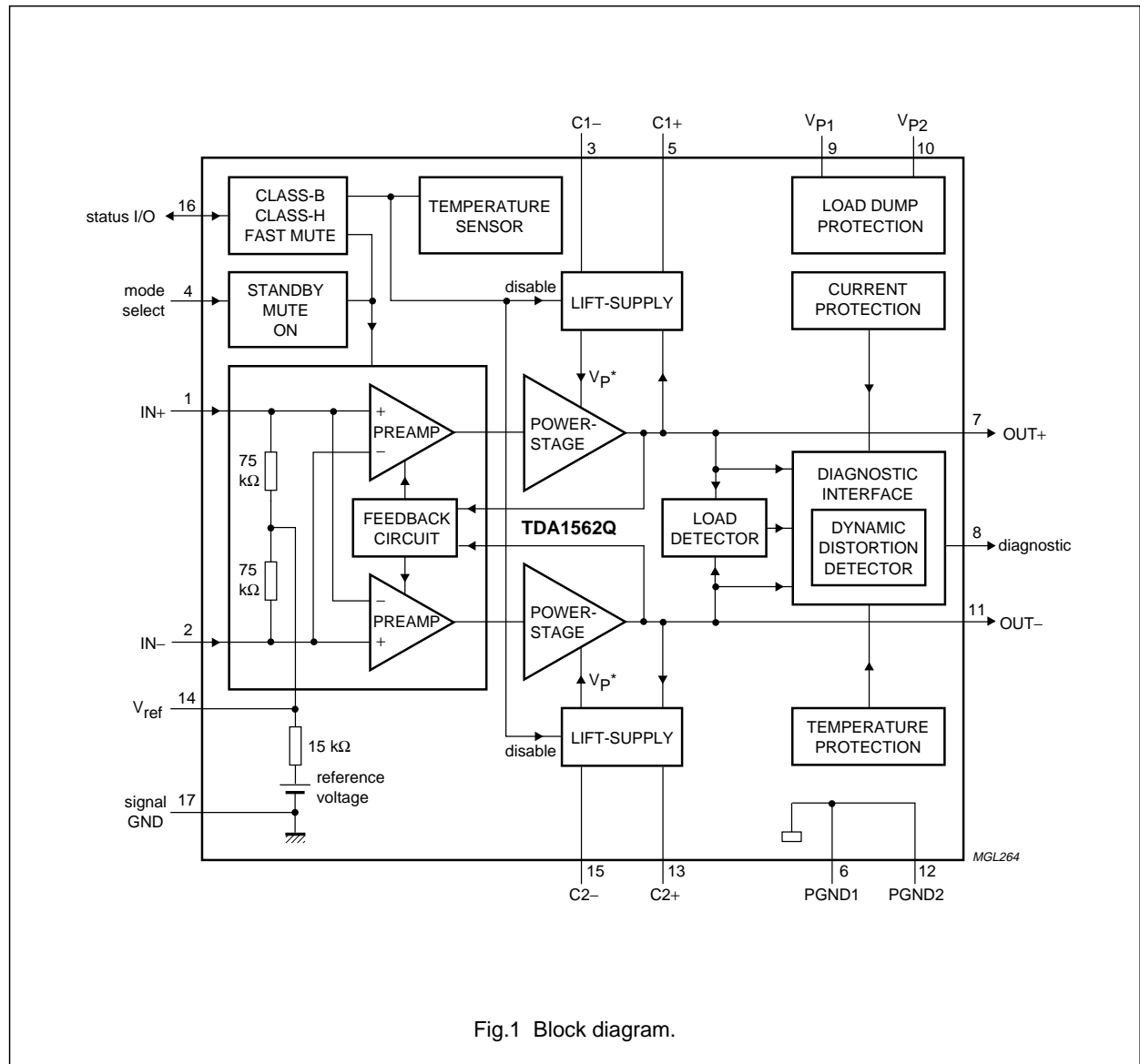

Fig.1 Block diagram.

70 W high efficiency power amplifier with diagnostic facility

TDA1562Q

PINNING

SYMBOL	PIN	DESCRIPTION
IN+	1	signal input (positive)
IN-	2	signal input (negative)
C1-	3	negative terminal of lift electrolytic capacitor 1
MODE	4	mode select input
C1+	5	positive terminal of lift electrolytic capacitor 1
PGND1	6	power ground 1
OUT+	7	positive output
DIAG	8	diagnostic output (open collector)
V _{P1}	9	supply voltage 1
V _{P2}	10	supply voltage 2
OUT-	11	negative output
PGND2	12	power ground 2
C2+	13	positive terminal of lift electrolytic capacitor 2
V _{ref}	14	internal reference voltage
C2-	15	negative terminal of lift electrolytic capacitor 2
STAT	16	status I/O
SGND	17	signal ground

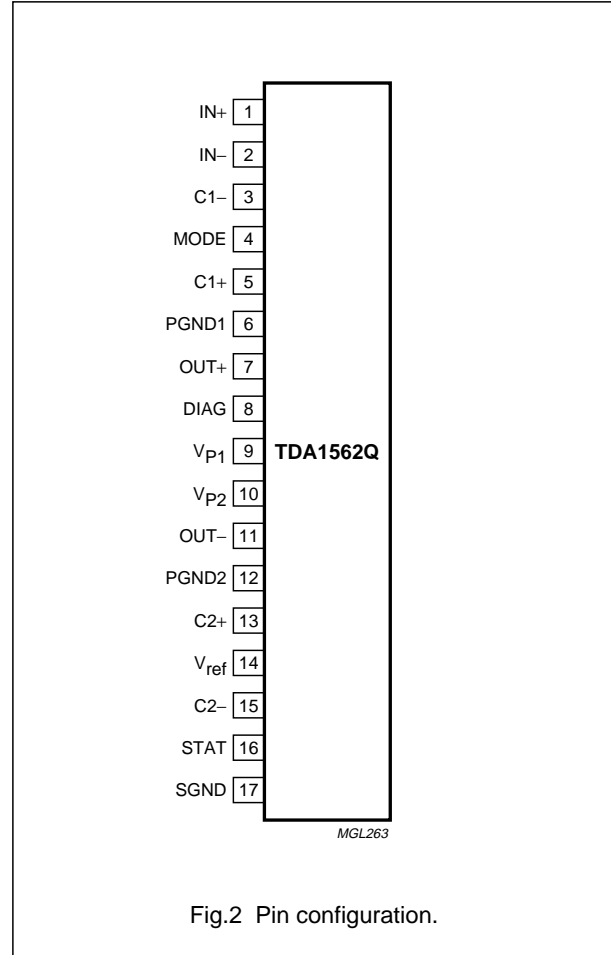

70 W high efficiency power amplifier with diagnostic facility

TDA1562Q

FUNCTIONAL DESCRIPTION

The TDA1562Q contains a mono class-H BTL output power amplifier. At low output power, up to 18 W, the device operates as a normal BTL amplifier. When a larger output voltage swing is required, the internal supply voltage is lifted by means of the external electrolytic capacitors. Due to this momentarily higher supply voltage the obtainable output power is 70 W.

In normal use, when the output is driven with music-like signals, the high output power is only needed during a small percentage of time. Under the assumption that a music signal has a normal (Gaussian) amplitude distribution, the reduction in dissipation is about 50% when compared to a class-B output amplifier with the same output power. The heatsink should be designed for use with music signals. If the case temperature exceeds 120 °C, the device will switch back from class-H to class-B operation. The high power supply voltage is then disabled and the output power is limited to 20 W.

When the supply voltage drops below the minimum operating level, the amplifier will be muted immediately.

Mode select input (pin MODE)

This pin has 3 modes:

1. LOW, 'standby': the complete circuit is switched off, the supply current is very low
2. MID, 'mute': the circuit is switched on, but the input signal is suppressed
3. HIGH, 'on': normal operation, the input signal is amplified by 26 dB.

When the circuit is switched from mute to on or vice versa the actual switching takes place at a zero crossing of the input signal. The circuit contains a **quick start** option, i.e. when it is switched directly from standby to on, the amplifier is fully operational within 50 ms (important for applications like car telephony and car navigation).

Status I/O input (pin STAT)

INPUT

This input has 3 possibilities:

1. LOW, 'fast mute': the circuit remains switched on, but the input signal is suppressed
2. MID, 'class-B': the circuit operates as class-B amplifier, the high power supply voltage is disabled, independent of the case temperature
3. HIGH, 'class-H': the circuit operates as class-H amplifier, the high power supply voltage is enabled, independent of the case temperature.

When the circuit is switched from fast mute to class-B/H or vice versa the switching is immediately carried out. When the circuit is switched from class-B to class-H or vice versa the actual switching takes place at a zero crossing of the input signal.

OUTPUT

This output has 3 possibilities:

1. LOW, 'mute': acknowledge of muted amplifier
2. MID, 'class-B': the circuit operates as class-B amplifier, the high power supply voltage is disabled, caused by the case temperature $T_c > 120$ °C
3. HIGH, 'class-H': the circuit operates as class-H amplifier, the high power supply voltage is enabled, because the case temperature $T_c < 120$ °C.

When the circuit is switched from class-B to class-H or vice versa the actual switching takes place at a zero crossing of the input signal.

The status I/O pins of **maximum 8 devices** may be tied together for synchronizing purposes.

70 W high efficiency power amplifier
with diagnostic facility

TDA1562Q

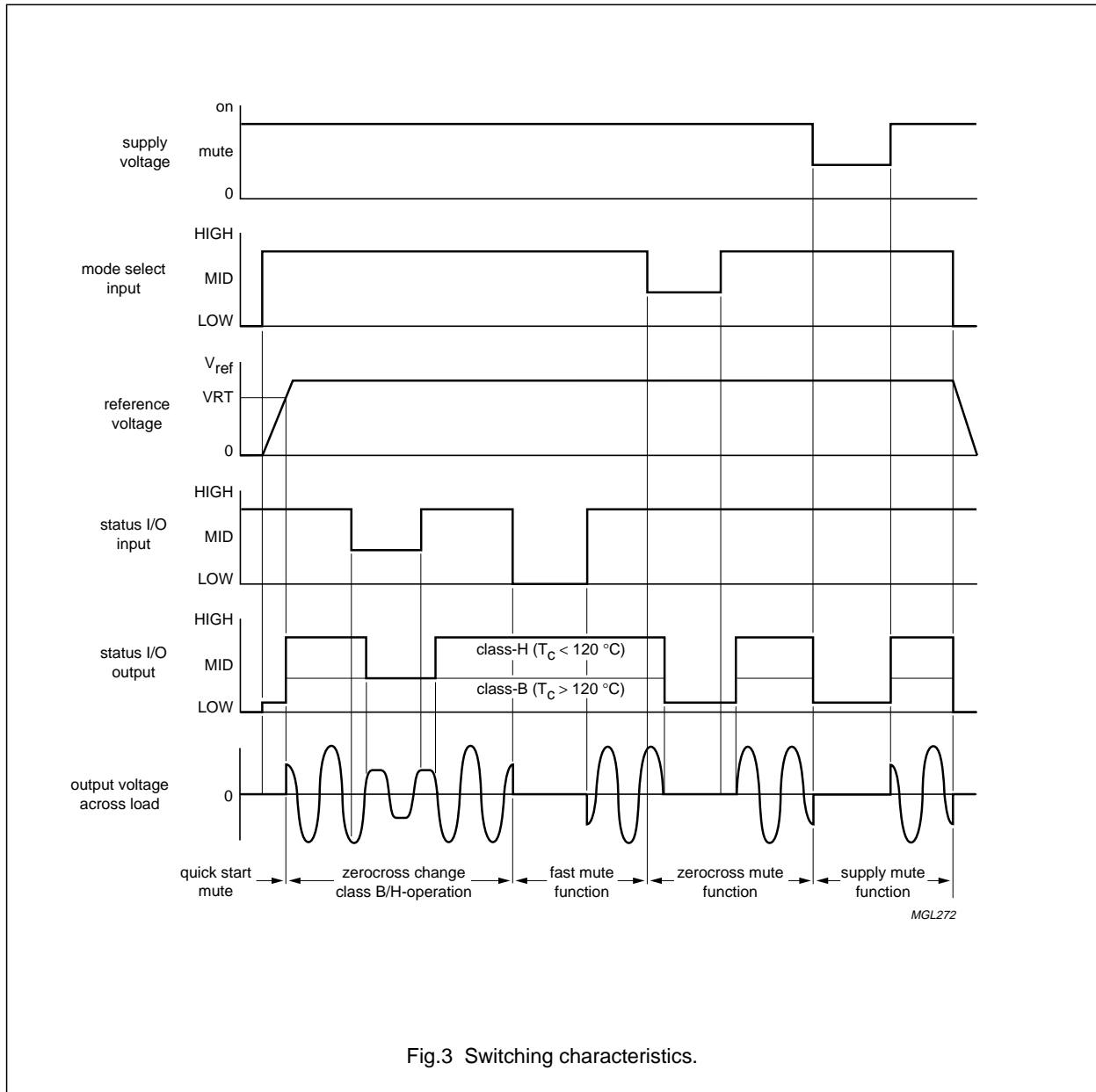

Fig.3 Switching characteristics.

70 W high efficiency power amplifier with diagnostic facility

TDA1562Q

Diagnostic output (pin DIAG)

DYNAMIC DISTORTION DETECTOR (DDD)

At the onset of clipping of the output stages, the DDD becomes active. This information can be used to drive a sound processor or DC-volume control to attenuate the input signal and so limit the distortion.

SHORT-CIRCUIT PROTECTION

When a short-circuit occurs at the outputs to ground or to the supply voltage, the output stages are switched off. They will be switched on again approximately 20 ms after removing the short-circuit. During this short-circuit condition the diagnostic output is continuously LOW.

When a short-circuit occurs across the load, the output stages are switched off during approximately 20 ms. After that time is checked during approximately 50 μ s whether the short-circuit is still present. During this short-circuit condition the diagnostic output is LOW for 20 ms and high for 50 μ s. The power dissipation in any short-circuit condition is very low.

TEMPERATURE DETECTION

Just before the temperature protection becomes active the diagnostic output becomes continuously LOW.

Load detection: directly after the circuit is switched from standby to mute or on, a build in detection circuit checks whether a load is present. The results of this check can be detected at the diagnostic output, by switching the mode select input in the mute mode.

Since the diagnostic output is an open collector output, more devices can be tied together.

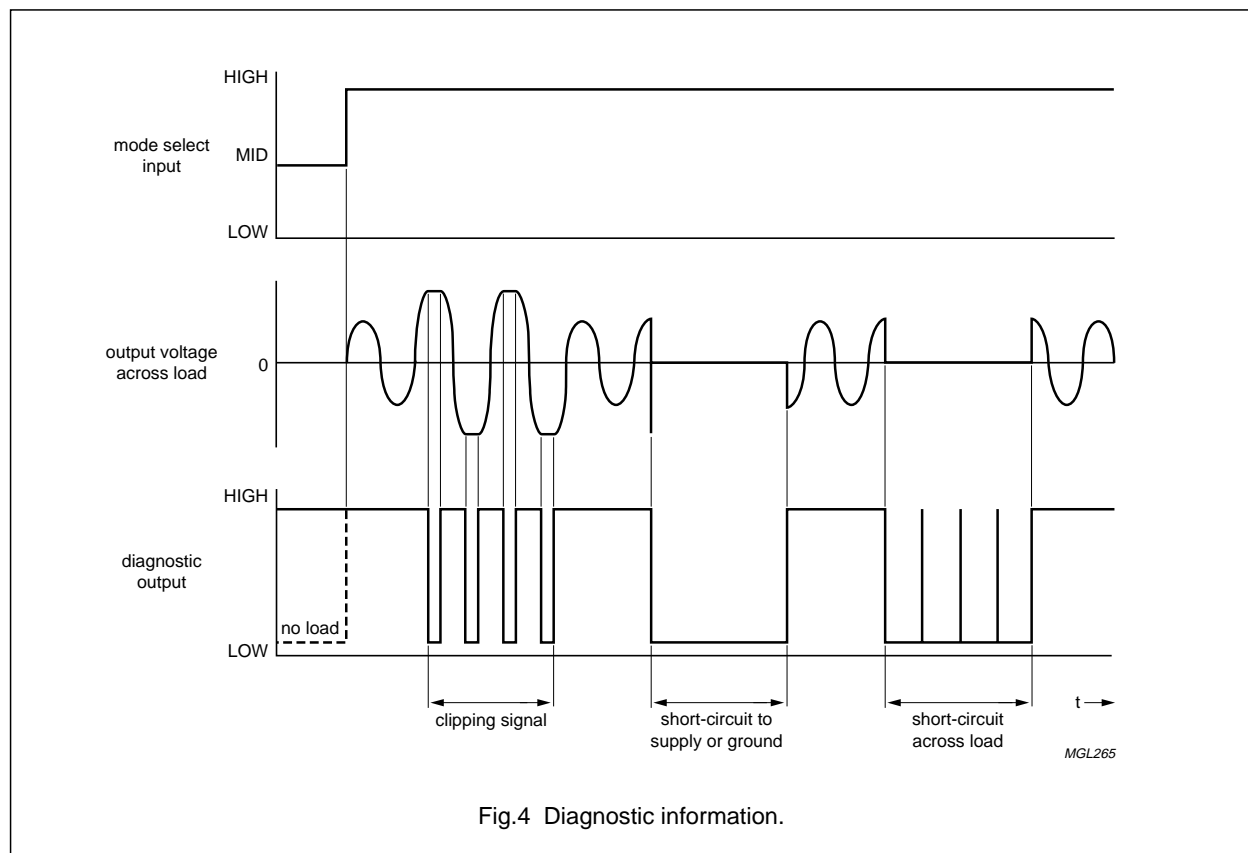
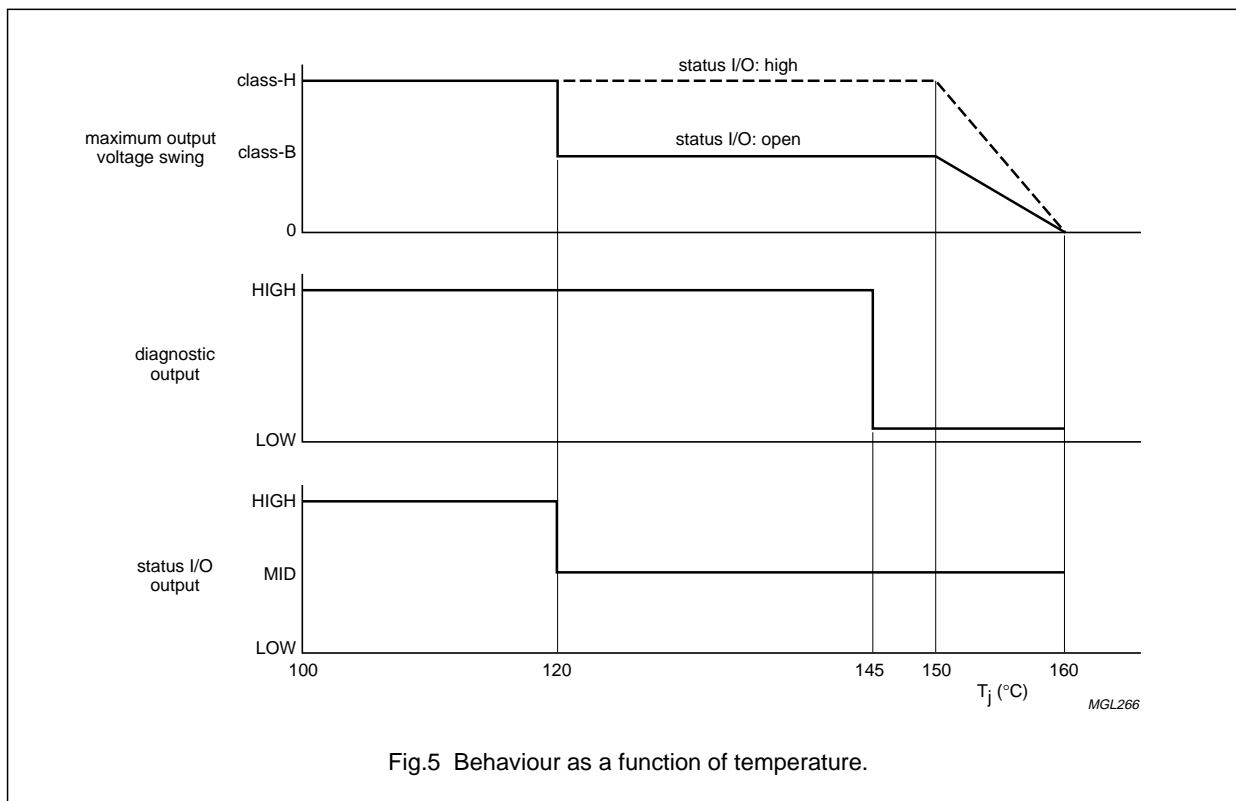

Fig.4 Diagnostic information.

70 W high efficiency power amplifier
with diagnostic facility

TDA1562Q



LIMITING VALUES

In accordance with the Absolute Maximum Rating System (IEC 134).

SYMBOL	PARAMETER	CONDITIONS	MIN.	MAX.	UNIT
V _P	supply voltage	operating	–	18	V
		non-operating	–	30	V
		load dump; t _r > 2.5 ms; T = 50 ms	–	45	V
I _{OSM}	non-repetitive peak output current		–	10	A
	repetitive peak output current		–	8	A
V _{SC}	short-circuit safe voltage		–	18	V
T _{stg}	storage temperature		–55	+150	°C
T _{amb}	ambient temperature		–40	–	°C
T _j	junction temperature	note 1	–	150	°C
P _{tot}	total power dissipation		–	60	W

Note

- T_j is a theoretical temperature which is based on a simplified representation of the thermal behaviour of the device.
T_j = T_c + P × R_{th(j-c)}, where R_{th(j-c)} is a fixed value to be used for the calculation of T_j. The rating for T_j limits the allowable combinations of power dissipation P and case temperature T_c (in accordance with IEC 747-1).

70 W high efficiency power amplifier with diagnostic facility

TDA1562Q

THERMAL CHARACTERISTICS

SYMBOL	PARAMETER	CONDITIONS	VALUE	UNIT
$R_{th(j-c)}$	thermal resistance from junction to case		1.5	K/W
$R_{th(j-a)}$	thermal resistance from junction to ambient	in free air	40	K/W

DC CHARACTERISTICS

$V_P = 14.4$ V; $R_L = 4$ Ω ; $T_{amb} = 25$ °C; measurements in accordance with Fig.10; unless otherwise specified.

SYMBOL	PARAMETER	CONDITIONS	MIN.	TYP.	MAX.	UNIT
Supplies V_{P1} and V_{P2} (pins 9 and 10)						
V_P	supply voltage		8	14.4	18	V
V_{th+}	supply threshold voltage	mute \rightarrow on	–	–	9	V
V_{th-}	supply threshold voltage	on \rightarrow mute	7	–	–	V
V_{PH1}	hysteresis $ (V_{th+} - V_{th-}) $		–	200	–	mV
I_q	quiescent current	on and mute; $R_L =$ open circuit	–	110	150	mA
I_{stb}	standby current	standby	–	1	50	μ A
Amplifier outputs OUT+ and OUT– (pins 7 and 11)						
V_O	DC output voltage	on and mute	–	6.5	–	V
$ V_{OO} $	output offset voltage	on and mute	–	–	100	mV
$ \Delta V_{OO} $	delta output offset voltage	on \leftrightarrow mute	–	–	30	mV
Mode select input MODE (pin 4)						
V_I	input voltage range		0	–	V_P	V
I_I	input current	$V_{MODE} = 14.4$ V	–	–	20	μ A
V_{th1+}	threshold voltage	standby \rightarrow mute	–	–	2	V
V_{th1-}	threshold voltage	mute \rightarrow standby	1	–	–	V
V_{msH1}	hysteresis $ (V_{th1+} - V_{th1-}) $		–	200	–	mV
V_{th2+}	threshold voltage	mute \rightarrow on	–	–	4.2	V
V_{th2-}	threshold voltage	on \rightarrow mute	3.3	–	–	V
V_{msH2}	hysteresis $ (V_{th2+} - V_{th2-}) $		–	200	–	mV
Status I/O STAT (pin 16)						
PIN STAT AS INPUT						
V_{st}	input voltage		0	–	V_P	V
I_{stH}	HIGH-level input current	$V_{STAT} = 14.4$ V	–	–	4	mA
I_{stL}	LOW-level input current	$V_{STAT} = 0$ V	–	–	–400	μ A
V_{th1+}	threshold voltage	fast mute \rightarrow class B	–	–	2	V
V_{th1-}	threshold voltage	class B \rightarrow fast mute	1	–	–	V
V_{stH1}	hysteresis $ (V_{th1+} - V_{th1-}) $		–	200	–	mV
V_{th2+}	threshold voltage	class B \rightarrow class H	–	–	4.2	V
V_{th2-}	threshold voltage	class H \rightarrow class B	3.3	–	–	V
V_{stH2}	hysteresis $ (V_{th2+} - V_{th1-}) $		–	200	–	mV

70 W high efficiency power amplifier
with diagnostic facility

TDA1562Q

SYMBOL	PARAMETER	CONDITIONS	MIN.	TYP.	MAX.	UNIT
PIN STAT AS OUTPUT						
$I_{st(mute)}$	mute acknowledge sink current		2.2	–	–	mA
$V_{st(mute)}$	mute acknowledge output voltage	$I_{st} = 2.2 \text{ mA}$	–	–	0.5	V
$I_{st(clB)}$	class B operation output current		15	–	–	μA
$V_{st(clB)}$	class B operation output voltage	$I_{st} = 15 \mu\text{A}$	2.0	–	3.0	V
$I_{st(clH)}$	class H operation source current		–140	–	–	μA
$V_{st(clH)}$	class H operation output voltage	$I_{st} = -140 \mu\text{A}$	$V_P - 2.5$	–	–	V
$T_{c(th)}$	threshold case temperature sensor		–	120	–	$^{\circ}\text{C}$
Diagnostic output DIAG (pin 8)						
V_{DIAG}	output voltage	active LOW	–	–	0.6	V
R_L	load resistance for open load detection		100	–	–	Ω
$T_{j(th)}$	threshold junction temperature sensor		–	145	–	$^{\circ}\text{C}$

70 W high efficiency power amplifier
with diagnostic facility

TDA1562Q

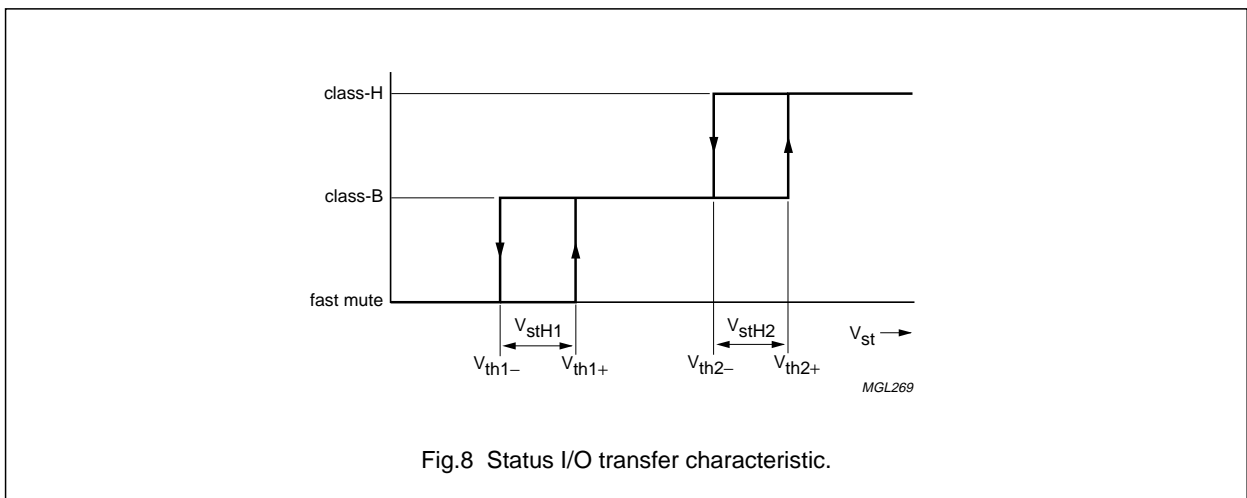
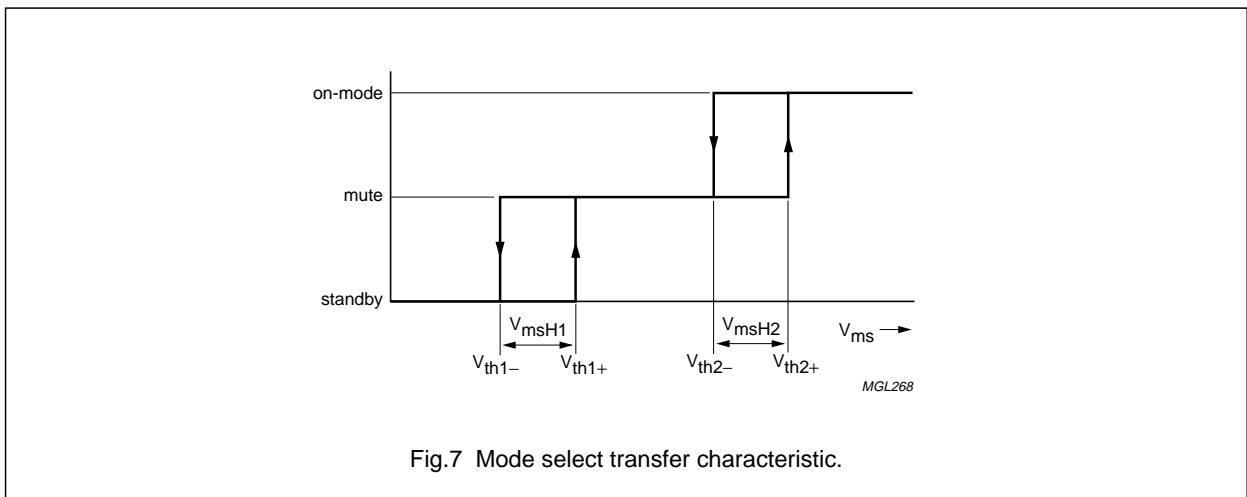
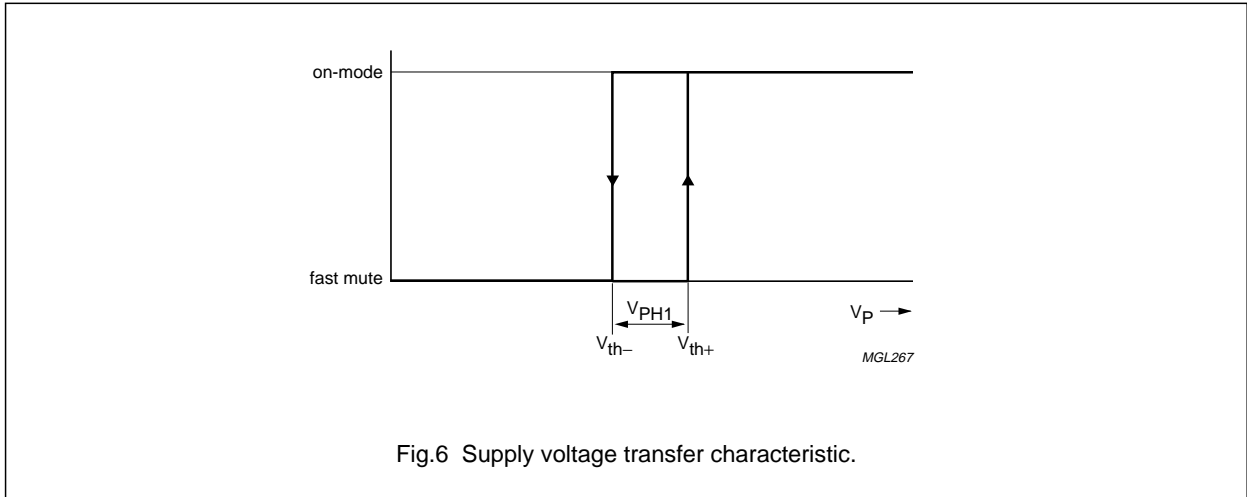

70 W high efficiency power amplifier with diagnostic facility

TDA1562Q

AC CHARACTERISTICS

$V_P = 14.4$; $R_L = 4 \Omega$; $R_S = 0 \Omega$; $f = 1 \text{ kHz}$; $T_{amb} = 25 \text{ }^\circ\text{C}$; measurements in accordance with Fig.10; unless otherwise specified.

SYMBOL	PARAMETER	CONDITIONS	MIN.	TYP.	MAX.	UNIT
P_o	output power	class-B; THD = 10%	16	20	–	W
		class-H; THD = 10%	60	70	–	W
		class-H; THD = 0.5%	45	55	–	W
$f_{ro(h)(P)}$	high frequency power roll-off	P_o (–1 dB); THD = 0.5%; note 1	–	20	–	kHz
THD	total harmonic distortion	$P_o = 1 \text{ W}$	–	0.03	–	%
		$P_o = 20 \text{ W}$	–	0.06	–	%
		DDD active	–	10	–	%
G_v	voltage gain		25	26	27	dB
$f_{ro(h)(G)}$	high frequency gain roll-off	G_v (–1 dB); note 2	20	–	–	kHz
$ Z_{i(dif)} $	differential input impedance		90	150	–	k Ω
SVRR	supply voltage ripple rejection	on and mute; note 3	60	70	–	dB
		standby; note 3		90	–	dB
CMRR	common mode rejection ratio	on; note 4	70	80	–	dB
ISRR	input signal rejection ratio	mute; note 5	80	90	–	dB
$V_{n(o)}$	noise output voltage	on; note 6	–	100	150	μV
		mute; notes 6 and 7	–	60	–	μV

Notes

- The low frequency power roll-off is determined by the value of the electrolytic lift capacitors.
- The low frequency gain roll-off is determined by the value of the input coupling capacitors.
- Supply voltage ripple rejection is measured across R_L ; $V_{ripple} = V_{ripple \text{ max.}} = 2 V_{PP}$.
- Common mode rejection ratio is measured across R_L ; $V_{cm} = V_{cm \text{ max.}} = 2 V_{PP}$. CMMR [dB] = differential gain (G_v) + common mode attenuation (A_c), (Test setup according Fig. 9; mismatch of input coupling capacitors **excluded**).
- Input signal rejection ratio is measured across R_L ; $V_i = V_{i(max)} = 2 V_{PP}$. ISSR [dB] = different gain (G_v) + mute attenuation (A_m)
- Noise output voltage is measured in a bandwidth of 20 Hz to 20 kHz.
- Noise output voltage is independent of source impedance R_S .

70 W high efficiency power amplifier with diagnostic facility

TDA1562Q

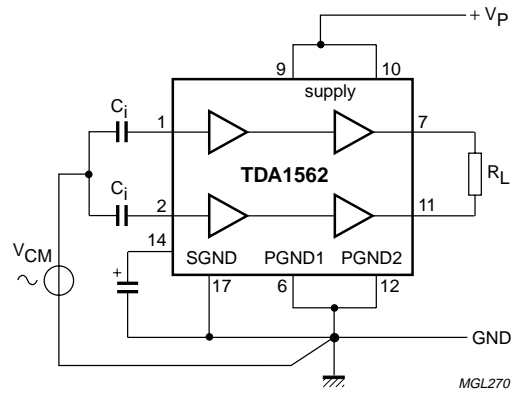

Fig.9 CMRR test setup.

QUALITY SPECIFICATION

Quality in accordance with "SNW-FQ-611 part E", if this type is used as an audio amplifier.

70 W high efficiency power amplifier with diagnostic facility

TDA1562Q

TEST AND APPLICATION INFORMATION

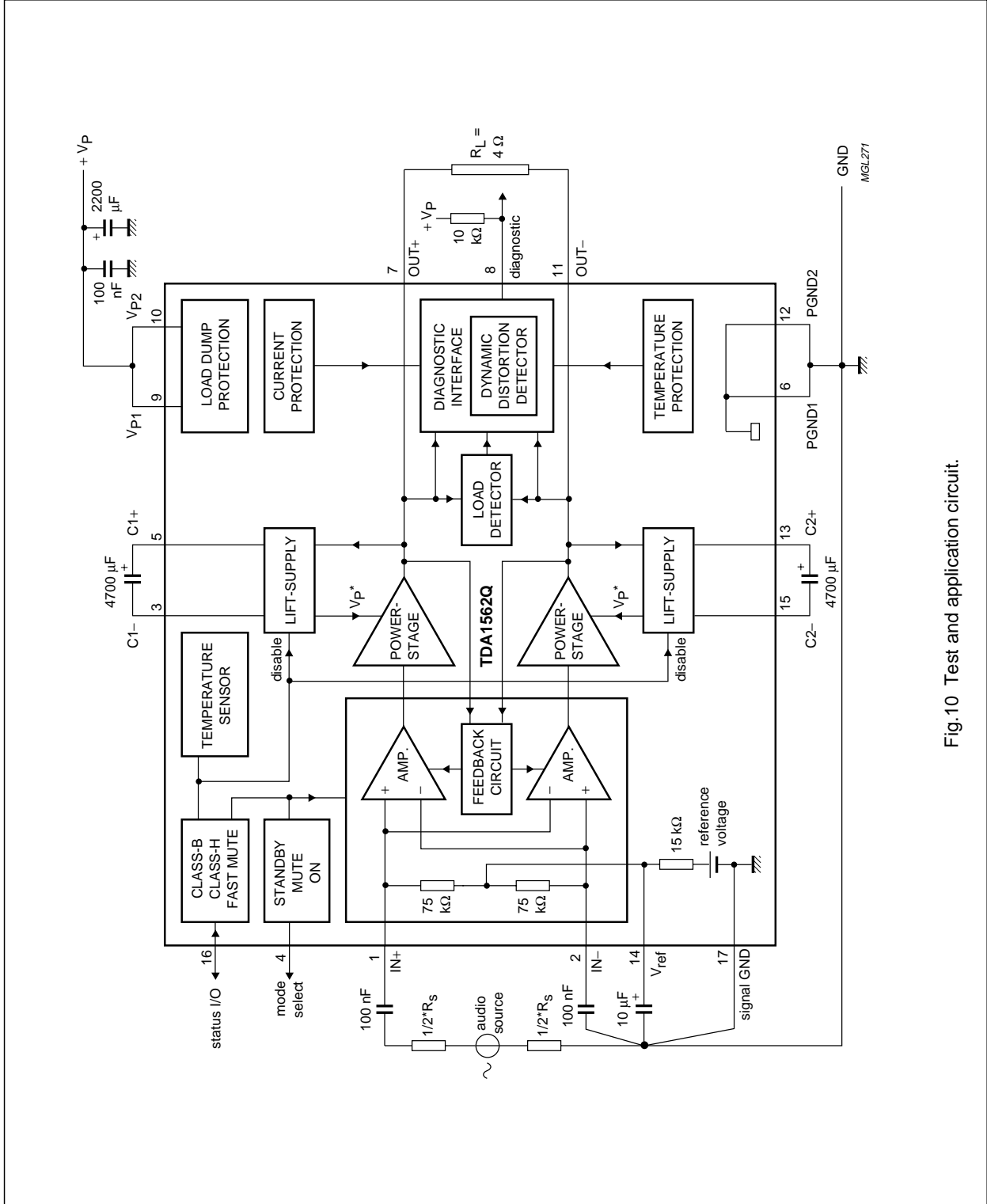

Fig.10 Test and application circuit.

70 W high efficiency power amplifier with diagnostic facility

TDA1562Q

PACKAGE OUTLINE

DBS17P: plastic DIL-bent-SIL power package; 17 leads (lead length 12 mm)

SOT243-1

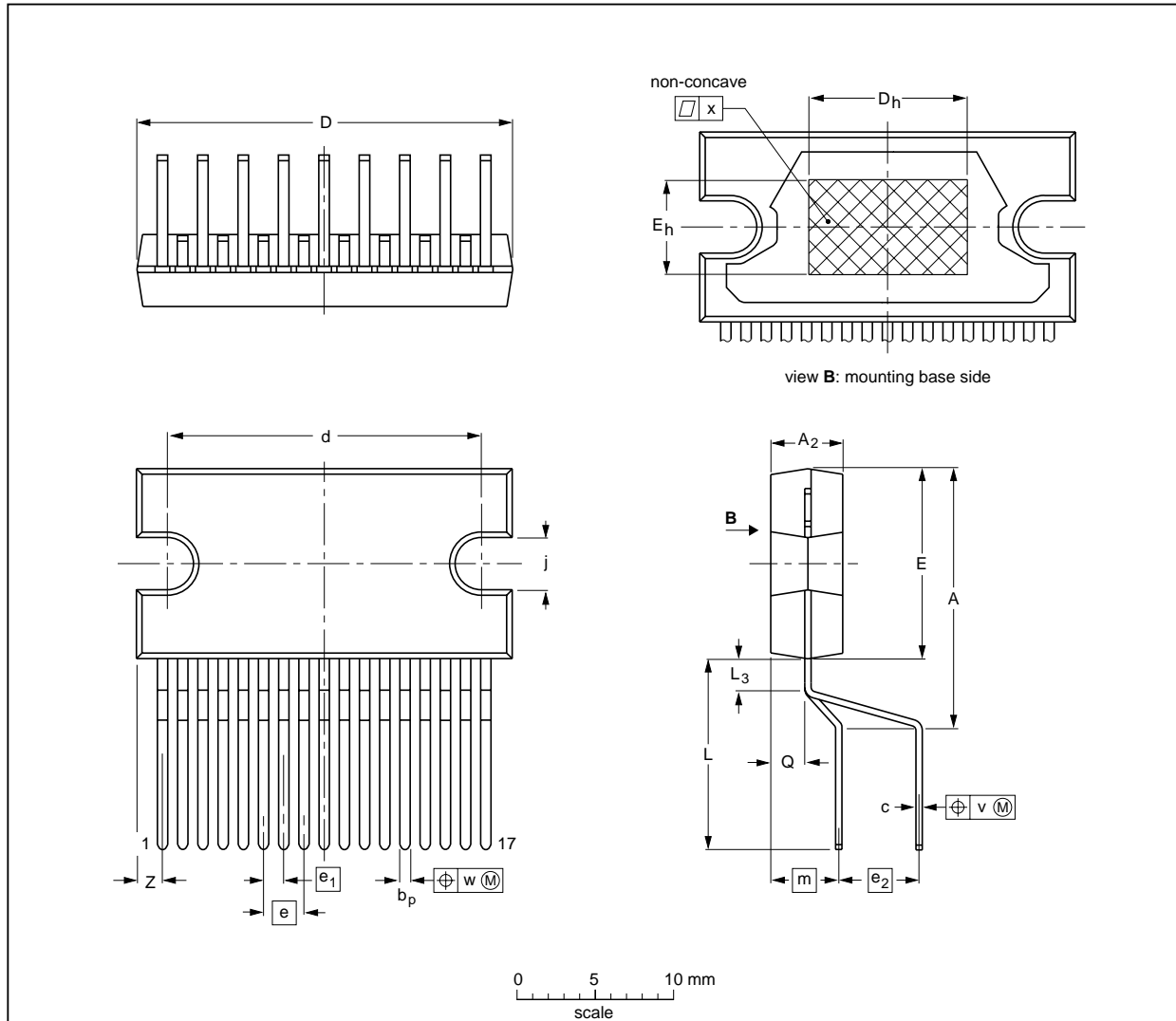

DIMENSIONS (mm are the original dimensions)

UNIT	A	A ₂	b _p	c	D ⁽¹⁾	d	D _h	E ⁽¹⁾	e	e ₁	e ₂	E _h	j	L	L ₃	m	Q	v	w	x	Z ⁽¹⁾
mm	17.0 15.5	4.6 4.2	0.75 0.60	0.48 0.38	24.0 23.6	20.0 19.6	10	12.2 11.8	2.54	1.27	5.08	6	3.4 3.1	12.4 11.0	2.4 1.6	4.3	2.1 1.8	0.8	0.4	0.03	2.00 1.45

Note

1. Plastic or metal protrusions of 0.25 mm maximum per side are not included.

OUTLINE VERSION	REFERENCES				EUROPEAN PROJECTION	ISSUE DATE
	IEC	JEDEC	EIAJ			
SOT243-1						95-03-11 97-12-16

70 W high efficiency power amplifier with diagnostic facility

TDA1562Q

SOLDERING

Introduction

There is no soldering method that is ideal for all IC packages. Wave soldering is often preferred when through-hole and surface mounted components are mixed on one printed-circuit board. However, wave soldering is not always suitable for surface mounted ICs, or for printed-circuits with high population densities. In these situations reflow soldering is often used.

This text gives a very brief insight to a complex technology. A more in-depth account of soldering ICs can be found in our *"IC Package Databook"* (order code 9398 652 90011).

Soldering by dipping or by wave

The maximum permissible temperature of the solder is 260 °C; solder at this temperature must not be in contact with the joint for more than 5 seconds. The total contact time of successive solder waves must not exceed 5 seconds.

The device may be mounted up to the seating plane, but the temperature of the plastic body must not exceed the specified maximum storage temperature ($T_{stg\ max}$). If the printed-circuit board has been pre-heated, forced cooling may be necessary immediately after soldering to keep the temperature within the permissible limit.

Repairing soldered joints

Apply a low voltage soldering iron (less than 24 V) to the lead(s) of the package, below the seating plane or not more than 2 mm above it. If the temperature of the soldering iron bit is less than 300 °C it may remain in contact for up to 10 seconds. If the bit temperature is between 300 and 400 °C, contact may be up to 5 seconds.

DEFINITIONS

Data sheet status	
Objective specification	This data sheet contains target or goal specifications for product development.
Preliminary specification	This data sheet contains preliminary data; supplementary data may be published later.
Product specification	This data sheet contains final product specifications.
Limiting values	
Limiting values given are in accordance with the Absolute Maximum Rating System (IEC 134). Stress above one or more of the limiting values may cause permanent damage to the device. These are stress ratings only and operation of the device at these or at any other conditions above those given in the Characteristics sections of the specification is not implied. Exposure to limiting values for extended periods may affect device reliability.	
Application information	
Where application information is given, it is advisory and does not form part of the specification.	

LIFE SUPPORT APPLICATIONS

These products are not designed for use in life support appliances, devices, or systems where malfunction of these products can reasonably be expected to result in personal injury. Philips customers using or selling these products for use in such applications do so at their own risk and agree to fully indemnify Philips for any damages resulting from such improper use or sale.

70 W high efficiency power amplifier
with diagnostic facility

TDA1562Q

NOTES

70 W high efficiency power amplifier
with diagnostic facility

TDA1562Q

NOTES

70 W high efficiency power amplifier
with diagnostic facility

TDA1562Q

NOTES

Philips Semiconductors – a worldwide company

Argentina: see South America

Australia: 34 Waterloo Road, NORTH RYDE, NSW 2113,
Tel. +61 2 9805 4455, Fax. +61 2 9805 4466

Austria: Computerstr. 6, A-1101 WIEN, P.O. Box 213, Tel. +43 160 1010,
Fax. +43 160 101 1210

Belarus: Hotel Minsk Business Center, Bld. 3, r. 1211, Volodarski Str. 6,
220050 MINSK, Tel. +375 172 200 733, Fax. +375 172 200 773

Belgium: see The Netherlands

Brazil: see South America

Bulgaria: Philips Bulgaria Ltd., Energoproject, 15th floor,
51 James Bouchier Blvd., 1407 SOFIA,
Tel. +359 2 689 211, Fax. +359 2 689 102

Canada: PHILIPS SEMICONDUCTORS/COMPONENTS,
Tel. +1 800 234 7381

China/Hong Kong: 501 Hong Kong Industrial Technology Centre,
72 Tat Chee Avenue, Kowloon Tong, HONG KONG,
Tel. +852 2319 7888, Fax. +852 2319 7700

Colombia: see South America

Czech Republic: see Austria

Denmark: Prags Boulevard 80, PB 1919, DK-2300 COPENHAGEN S,
Tel. +45 32 88 2636, Fax. +45 31 57 0044

Finland: Sinikalliontie 3, FIN-02630 ESPOO,
Tel. +358 9 615800, Fax. +358 9 61580920

France: 51 Rue Carnot, BP317, 92156 SURESNES Cedex,
Tel. +33 1 40 99 6161, Fax. +33 1 40 99 6427

Germany: Hammerbrookstraße 69, D-20097 HAMBURG,
Tel. +49 40 23 53 60, Fax. +49 40 23 536 300

Greece: No. 15, 25th March Street, GR 17778 TAVROS/ATHENS,
Tel. +30 1 4894 339/239, Fax. +30 1 4814 240

Hungary: see Austria

India: Philips INDIA Ltd, Band Box Building, 2nd floor,
254-D, Dr. Annie Besant Road, Worli, MUMBAI 400 025,
Tel. +91 22 493 8541, Fax. +91 22 493 0966

Indonesia: PT Philips Development Corporation, Semiconductors Division,
Gedung Philips, Jl. Buncit Raya Kav.99-100, JAKARTA 12510,
Tel. +62 21 794 0040 ext. 2501, Fax. +62 21 794 0080

Ireland: Newstead, Clonskeagh, DUBLIN 14,
Tel. +353 1 7640 000, Fax. +353 1 7640 200

Israel: RAPAC Electronics, 7 Kehilat Saloniki St, PO Box 18053,
TEL AVIV 61180, Tel. +972 3 645 0444, Fax. +972 3 649 1007

Italy: PHILIPS SEMICONDUCTORS, Piazza IV Novembre 3,
20124 MILANO, Tel. +39 2 6752 2531, Fax. +39 2 6752 2557

Japan: Philips Bldg 13-37, Kohnan 2-chome, Minato-ku, TOKYO 108,
Tel. +81 3 3740 5130, Fax. +81 3 3740 5077

Korea: Philips House, 260-199 Itaewon-dong, Yongsan-ku, SEOUL,
Tel. +82 2 709 1412, Fax. +82 2 709 1415

Malaysia: No. 76 Jalan Universiti, 46200 PETALING JAYA, SELANGOR,
Tel. +60 3 750 5214, Fax. +60 3 757 4880

Mexico: 5900 Gateway East, Suite 200, EL PASO, TEXAS 79905,
Tel. +9-5 800 234 7381

Middle East: see Italy

Netherlands: Postbus 90050, 5600 PB EINDHOVEN, Bldg. VB,
Tel. +31 40 27 82785, Fax. +31 40 27 88399

New Zealand: 2 Wagener Place, C.P.O. Box 1041, AUCKLAND,
Tel. +64 9 849 4160, Fax. +64 9 849 7811

Norway: Box 1, Manglerud 0612, OSLO,
Tel. +47 22 74 8000, Fax. +47 22 74 8341

Pakistan: see Singapore

Philippines: Philips Semiconductors Philippines Inc.,
106 Valero St. Salcedo Village, P.O. Box 2108 MCC, MAKATI,
Metro MANILA, Tel. +63 2 816 6380, Fax. +63 2 817 3474

Poland: Ul. Lukiska 10, PL 04-123 WARSZAWA,
Tel. +48 22 612 2831, Fax. +48 22 612 2327

Portugal: see Spain

Romania: see Italy

Russia: Philips Russia, Ul. Usatcheva 35A, 119048 MOSCOW,
Tel. +7 095 755 6918, Fax. +7 095 755 6919

Singapore: Lorong 1, Toa Payoh, SINGAPORE 319762,
Tel. +65 350 2538, Fax. +65 251 6500

Slovakia: see Austria

Slovenia: see Italy

South Africa: S.A. PHILIPS Pty Ltd., 195-215 Main Road Martindale,
2092 JOHANNESBURG, P.O. Box 7430 Johannesburg 2000,
Tel. +27 11 470 5911, Fax. +27 11 470 5494

South America: Al. Vicente Pinzon, 173, 6th floor,
04547-130 SÃO PAULO, SP, Brazil,
Tel. +55 11 821 2333, Fax. +55 11 821 2382

Spain: Balmes 22, 08007 BARCELONA,
Tel. +34 3 301 6312, Fax. +34 3 301 4107

Sweden: Kottbygatan 7, Akalla, S-16485 STOCKHOLM,
Tel. +46 8 5985 2000, Fax. +46 8 5985 2745

Switzerland: Allmendstrasse 140, CH-8027 ZÜRICH,
Tel. +41 1 488 2741 Fax. +41 1 488 3263

Taiwan: Philips Semiconductors, 6F, No. 96, Chien Kuo N. Rd., Sec. 1,
TAIPEI, Taiwan Tel. +886 2 2134 2865, Fax. +886 2 2134 2874

Thailand: PHILIPS ELECTRONICS (THAILAND) Ltd.,
209/2 Sanpavuth-Bangna Road Prakanong, BANGKOK 10260,
Tel. +66 2 745 4090, Fax. +66 2 398 0793

Turkey: Talatpasa Cad. No. 5, 80640 GÜLTEPE/ISTANBUL,
Tel. +90 212 279 2770, Fax. +90 212 282 6707

Ukraine: PHILIPS UKRAINE, 4 Patrice Lumumba str., Building B, Floor 7,
252042 KIEV, Tel. +380 44 264 2776, Fax. +380 44 268 0461

United Kingdom: Philips Semiconductors Ltd., 276 Bath Road, Hayes,
MIDDLESEX UB3 5BX, Tel. +44 181 730 5000, Fax. +44 181 754 8421

United States: 811 East Arques Avenue, SUNNYVALE, CA 94088-3409,
Tel. +1 800 234 7381

Uruguay: see South America

Vietnam: see Singapore

Yugoslavia: PHILIPS, Trg N. Pasica 5/v, 11000 BEOGRAD,
Tel. +381 11 625 344, Fax. +381 11 635 777

For all other countries apply to: Philips Semiconductors,
International Marketing & Sales Communications, Building BE-p, P.O. Box 218,
5600 MD EINDHOVEN, The Netherlands, Fax. +31 40 27 24825

Internet: <http://www.semiconductors.philips.com>

© Philips Electronics N.V. 1998

SCA59

All rights are reserved. Reproduction in whole or in part is prohibited without the prior written consent of the copyright owner.

The information presented in this document does not form part of any quotation or contract, is believed to be accurate and reliable and may be changed without notice. No liability will be accepted by the publisher for any consequence of its use. Publication thereof does not convey nor imply any license under patent- or other industrial or intellectual property rights.

Printed in The Netherlands

545102/1200/01/pp20

Date of release: 1998 Apr 07

Document order number: 9397 750 03043

Let's make things better.

**Philips
Semiconductors**



PHILIPS