

## Subminiature Transmissive Optical Sensor with Phototransistor Output

### Description

TCPT1200 has a compact construction where emitter and detector is located face to face on the same optical axes. The operating wavelength is 950 nm.

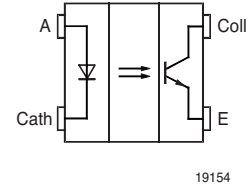

### Features

- IR Emitter wavelength 950 nm
- Gap 2 mm
- Package height: 4 mm
- Surface Mountable Device (SMD)
- Lead-free component
- Component in accordance to RoHS 2002/95/EC and WEEE 2002/96/EC

### Applications

Accurate position sensor for encoder  
 Detection of motion direction  
 Computer mouse and track-balls

### Parts Table

Part	Resolution	Aperture	MOQ	Remarks
TCPT1200	0.24 mm	0.3 mm	2000 pc	Tape and Reel

### Absolute Maximum Ratings

#### Coupler

Parameter	Test condition	Symbol	Value	Unit
Total power dissipation	$T_{amb} \leq 25^{\circ}\text{C}$	$P_{tot}$	150	mW
Ambient temperature range		$T_{amb}$	-40 to +85	$^{\circ}\text{C}$
Storage temperature range		$T_{stg}$	-40 to +100	$^{\circ}\text{C}$
Soldering temperature	in accordance to released reflow solder profile	$T_{sd}$	260	$^{\circ}\text{C}$

#### Input (Emitter)

Parameter	Test condition	Symbol	Value	Unit
Reverse voltage		$V_R$	5	V
Forward current		$I_F$	25	mA
Pulse forward current	$t_p = 0.1 \text{ ms}; t_p / T = 0.01$	$I_{FP}$	100	mA
Power dissipation	$T_{amb} \leq 25^{\circ}\text{C}$	$P_V$	75	mW

## Output (Detector)

Parameter	Test condition	Symbol	Value	Unit
Collector emitter voltage		$V_{CEO}$	70	V
Emitter collector voltage		$V_{ECO}$	7	V
Collector current		$I_C$	20	mA
Power dissipation	$T_{amb} \leq 25^\circ\text{C}$	$P_V$	75	mW

## Electrical Characteristics

### Coupler

$T_{amb} = 25^\circ\text{C}$ , unless otherwise specified

Parameter	Test condition	Symbol	Min	Typ.	Max	Unit
Collector current	$V_{CE} = 5\text{ V}$ , $I_F = 15\text{ mA}$	$I_C$	300	500		$\mu\text{A}$
Collector emitter saturation voltage	$I_F = 15\text{ mA}$ , $I_C = 0.05\text{ mA}$	$V_{CEsat}$			0.4	V

### Input (Emitter)

Parameter	Test condition	Symbol	Min	Typ.	Max	Unit
Forward voltage	$I_F = 15\text{ mA}$	$V_F$		1.2	1.5	V
Reverse current	$V_R = 5\text{ V}$	$I_R$			10	$\mu\text{A}$
Junction capacitance	$V_R = 0\text{ V}$ , $f = 1\text{ MHz}$	$C_j$		50		pF

### Output (Detector)

Parameter	Test condition	Symbol	Min	Typ.	Max	Unit
Collector emitter voltage	$I_C = 1\text{ mA}$	$V_{CEO}$	70			V
Emitter collector voltage	$I_E = 100\ \mu\text{A}$	$V_{ECO}$	7			V
Collector-emitter cut-off current	$V_{CE} = 25\text{ V}$ , $I_F = 0$ , $E = 0$	$I_{CEO}$		10	100	nA

## Switching Characteristics

$T_{amb} = 25^\circ\text{C}$ , unless otherwise specified

Parameter	Test condition	Symbol	Min	Typ.	Max	Unit
Rise time	$I_C = 0.3\text{ mA}$ , $V_{CE} = 5\text{ V}$ , $R_L = 1000\ \Omega$ (see figure 2)	$t_r$		20.0	150	$\mu\text{s}$
Fall time	$I_C = 0.3\text{ mA}$ , $V_{CE} = 5\text{ V}$ , $R_L = 1000\ \Omega$ (see figure 2)	$t_f$		30.0	150	$\mu\text{s}$

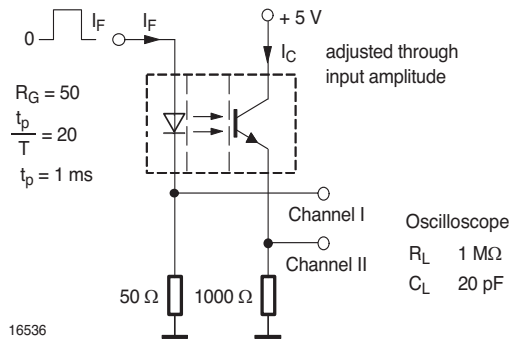

Figure 1. Test Circuit for  $t_r$  and  $t_f$

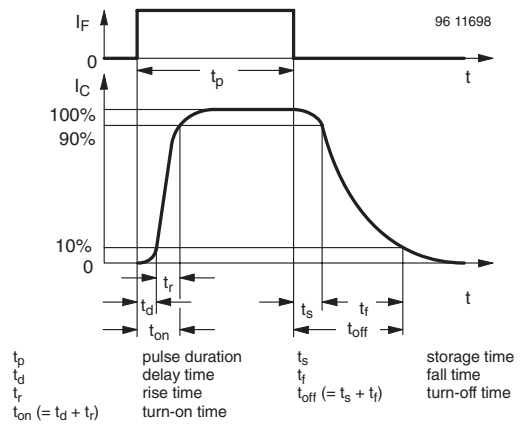

Figure 2. Switching Times

## Typical Characteristics ( $T_{amb} = 25\text{ }^\circ\text{C}$ unless otherwise specified)

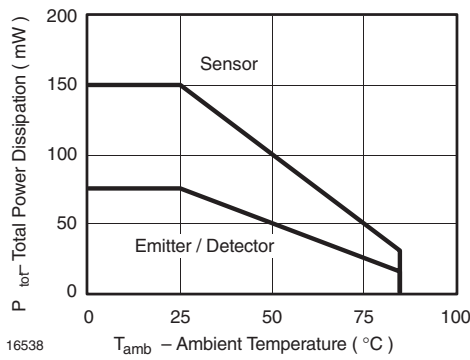

Figure 3. Derating diagram

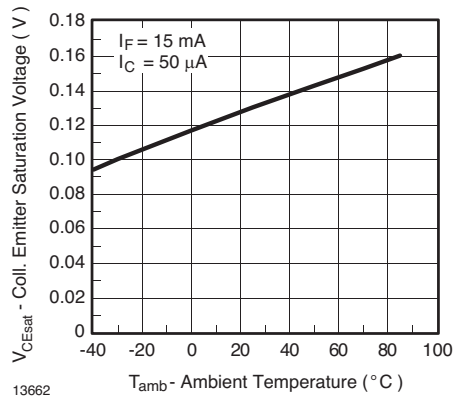

Figure 5. Collector Emitter Saturation Voltage vs. Ambient Temperature

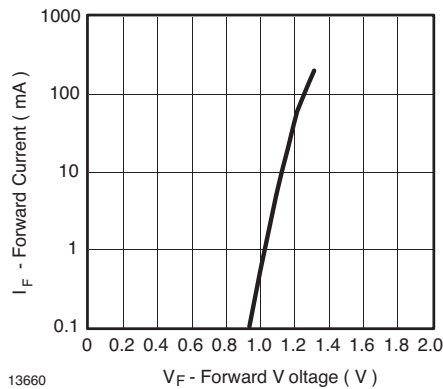

Figure 4. Forward Current vs. Forward Voltage

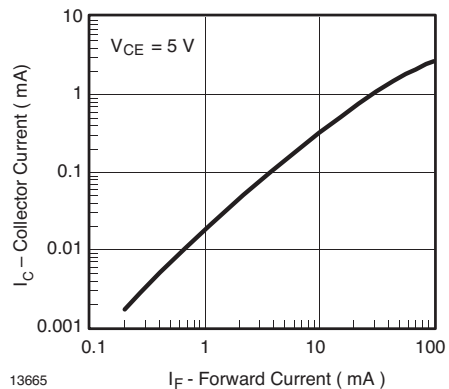

Figure 6. Collector Current vs. Forward Current

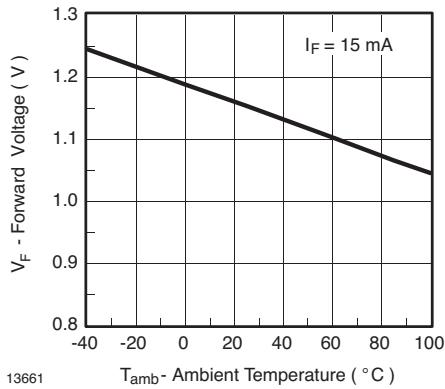

Figure 7. Forward Voltage vs. Ambient Temperature

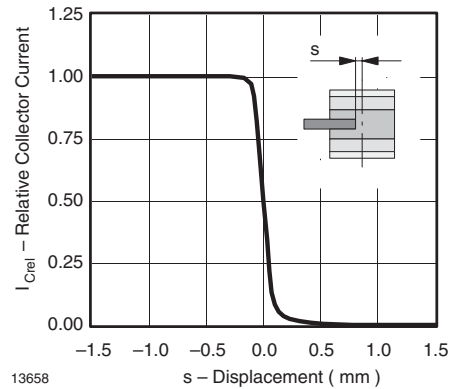

Figure 10. Relative Collector Current vs. Displacement

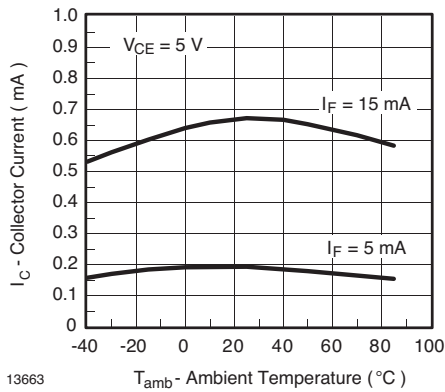

Figure 8. Collector Current vs. Ambient Temperature

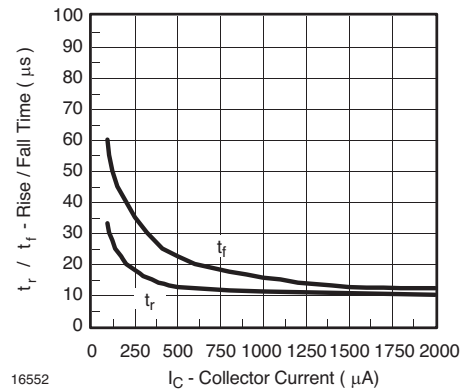

Figure 11. Rise/ Fall Time vs. Collector Current

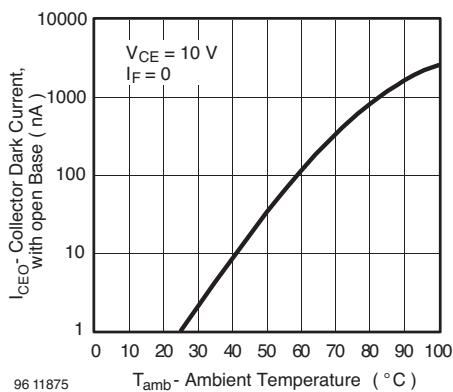

Figure 9. Collector Dark Current vs. Ambient Temperature

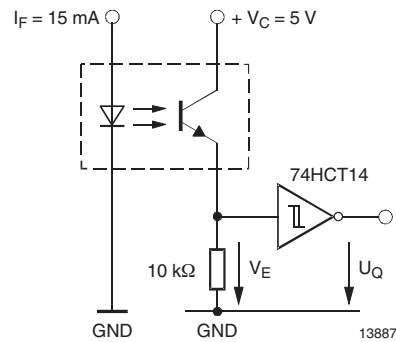

Figure 12. Application example

### Reflow Solder Profiles

file (figure 13)

Floor Life: 12 month (level 2) or 168 hours (level 3)

Floor Conditions:  $T_{amb} < 30\text{ }^{\circ}\text{C}$ ,  $\text{RH} < 60\%$

### Drying

In case of moisture absorption devices should be baked before soldering. Conditions see J-STD-020 or Label. Devices taped on reel dry using recommended conditions 192 h @  $40\text{ }^{\circ}\text{C}$  ( $\pm 5\text{ }^{\circ}\text{C}$ ),  $\text{RH} < 5\%$  or 96 h @  $60\text{ }^{\circ}\text{C}$  ( $\pm 5\text{ }^{\circ}\text{C}$ ),  $\text{RH} < 5\%$

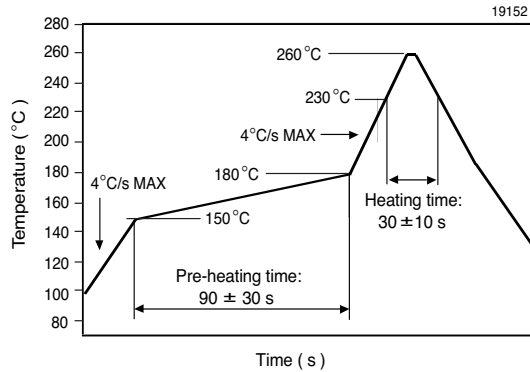

Figure 13. Lead-Free (Sn) Reflow Solder Profile

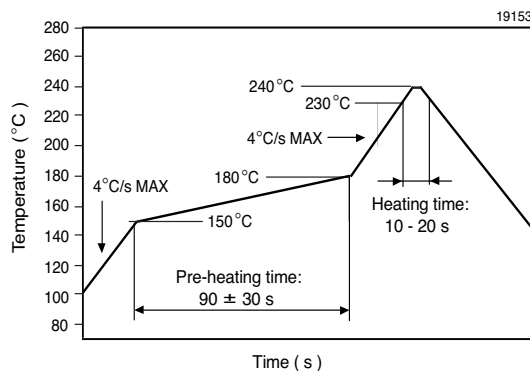

Figure 14. Lead Tin (SnPb) Reflow Solder Profile

### Drypack

Devices are packed in moisture barrier bags (MBB) to prevent the products from moisture absorption during transportation and storage. Each bag contains a desiccant.

### Floor Life

Floor life (time between soldering and removing from MBB) must not exceed the time indicated in J-STD-020. Acc. JEDEC, J-STD-020, TCPT1200 is released to Moisture Sensitivity Level 2, for use of Lead Tin (SnPb) Reflow Solder Profile (figure 14) or Level 3, for use of Lead-free (Sn) Reflow Solder Pro-

## Dimensions of Reel and Tape

Reel-dimension and shape:

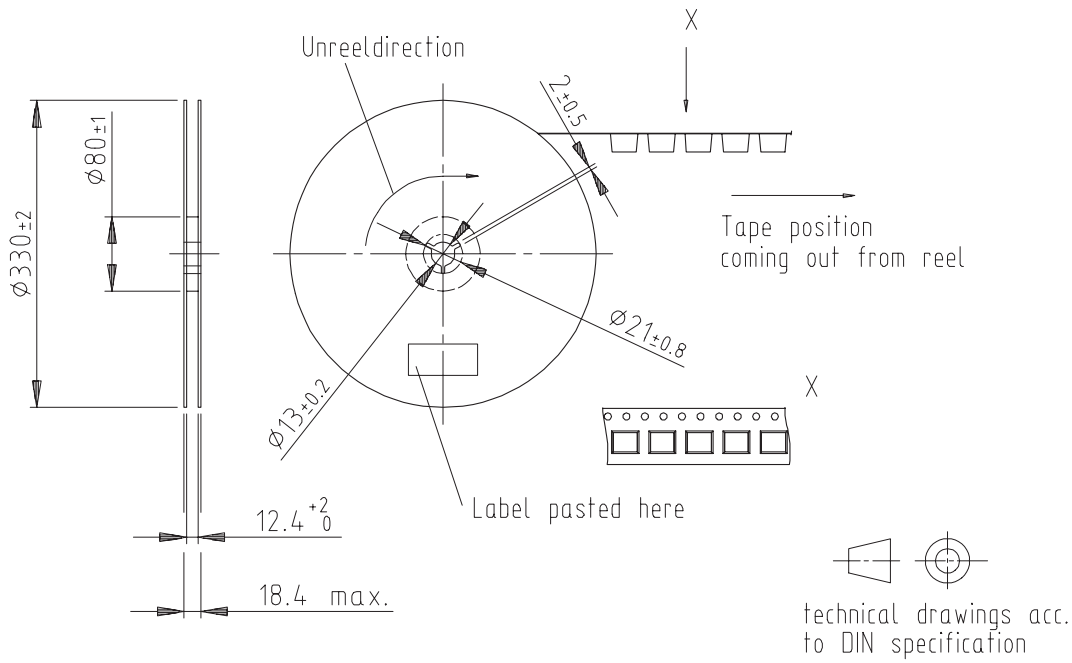

Leader and trailer tape:

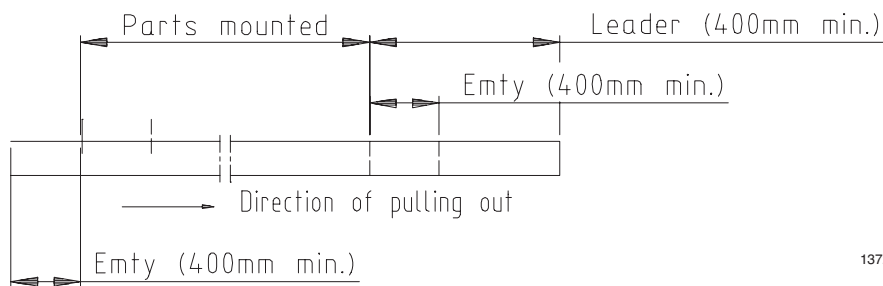

13722

## Dimensions of Tape

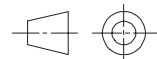
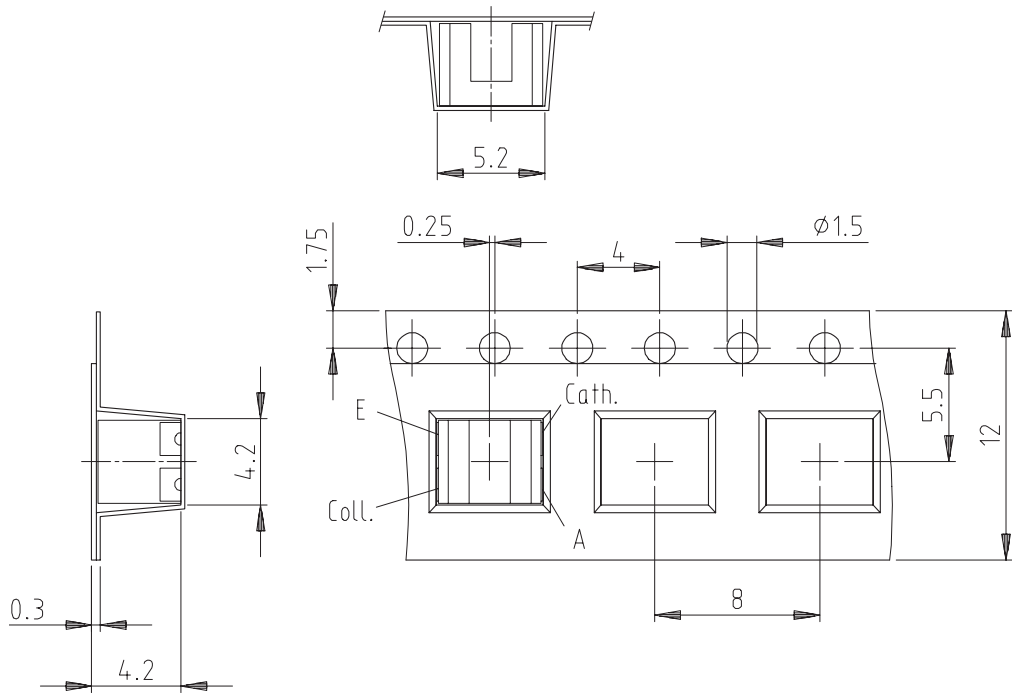

technical drawings acc.  
to DIN specification

13721

Quantity per reel: 2000 pcs.

## Package Dimensions in mm

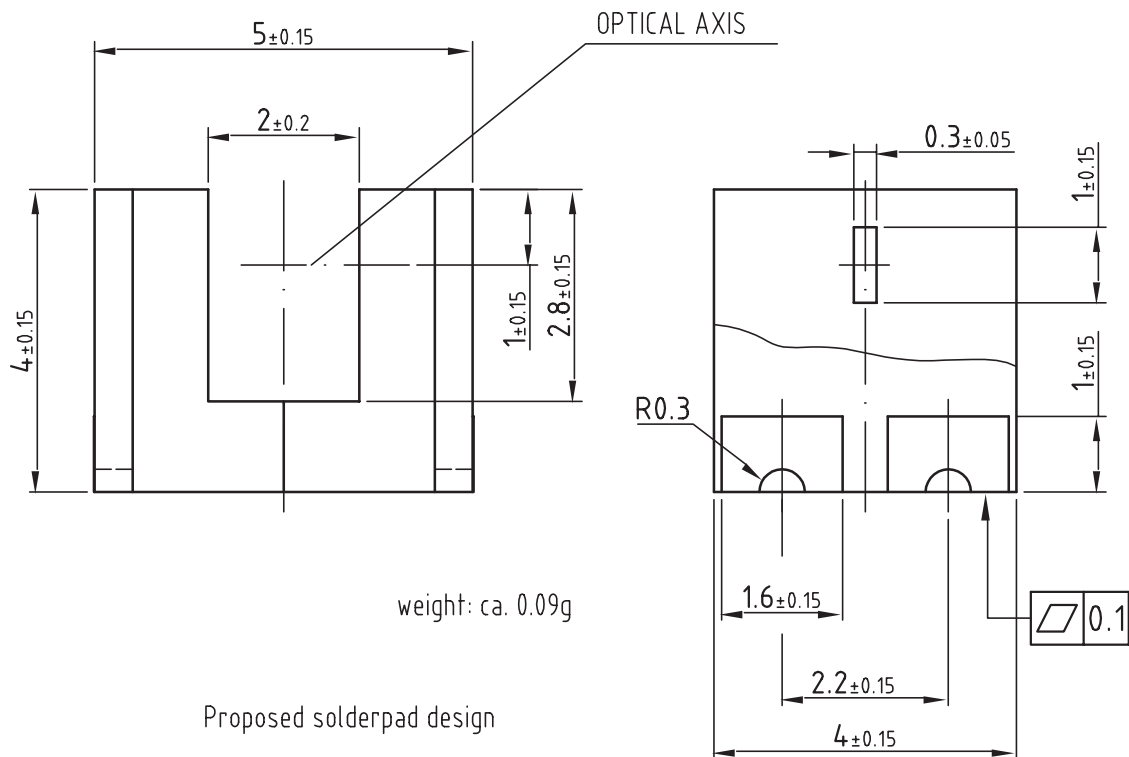

Proposed solderpad design

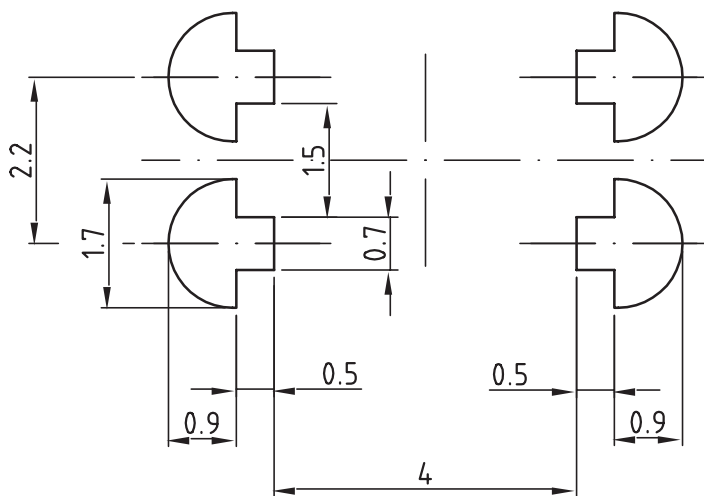

Pin connection  
Top view

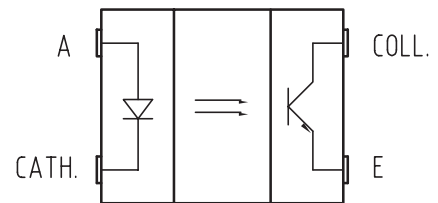

All dimensions in mm incl. burrs

Soldering terminal free from  
contamination and burr

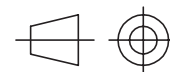

technical drawings  
according to DIN  
specifications

Drawing-No.: 6.541-5043.01-4

Issue: 12; 17.12.04

19310

## **Ozone Depleting Substances Policy Statement**

It is the policy of Vishay Semiconductor GmbH to

1. Meet all present and future national and international statutory requirements.
2. Regularly and continuously improve the performance of our products, processes, distribution and operating systems with respect to their impact on the health and safety of our employees and the public, as well as their impact on the environment.

It is particular concern to control or eliminate releases of those substances into the atmosphere which are known as ozone depleting substances (ODSs).

The Montreal Protocol (1987) and its London Amendments (1990) intend to severely restrict the use of ODSs and forbid their use within the next ten years. Various national and international initiatives are pressing for an earlier ban on these substances.

Vishay Semiconductor GmbH has been able to use its policy of continuous improvements to eliminate the use of ODSs listed in the following documents.

1. Annex A, B and list of transitional substances of the Montreal Protocol and the London Amendments respectively
2. Class I and II ozone depleting substances in the Clean Air Act Amendments of 1990 by the Environmental Protection Agency (EPA) in the USA
3. Council Decision 88/540/EEC and 91/690/EEC Annex A, B and C (transitional substances) respectively.

Vishay Semiconductor GmbH can certify that our semiconductors are not manufactured with ozone depleting substances and do not contain such substances.

We reserve the right to make changes to improve technical design and may do so without further notice.

Parameters can vary in different applications. All operating parameters must be validated for each customer application by the customer. Should the buyer use Vishay Semiconductors products for any unintended or unauthorized application, the buyer shall indemnify Vishay Semiconductors against all claims, costs, damages, and expenses, arising out of, directly or indirectly, any claim of personal damage, injury or death associated with such unintended or unauthorized use.

Vishay Semiconductor GmbH, P.O.B. 3535, D-74025 Heilbronn, Germany  
Telephone: 49 (0)7131 67 2831, Fax number: 49 (0)7131 67 2423



---

**Notice**

Specifications of the products displayed herein are subject to change without notice. Vishay Intertechnology, Inc., or anyone on its behalf, assumes no responsibility or liability for any errors or inaccuracies.

Information contained herein is intended to provide a product description only. No license, express or implied, by estoppel or otherwise, to any intellectual property rights is granted by this document. Except as provided in Vishay's terms and conditions of sale for such products, Vishay assumes no liability whatsoever, and disclaims any express or implied warranty, relating to sale and/or use of Vishay products including liability or warranties relating to fitness for a particular purpose, merchantability, or infringement of any patent, copyright, or other intellectual property right.

The products shown herein are not designed for use in medical, life-saving, or life-sustaining applications. Customers using or selling these products for use in such applications do so at their own risk and agree to fully indemnify Vishay for any damages resulting from such improper use or sale.