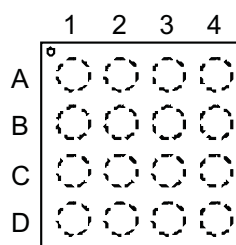

# Low-Voltage 8-Bit I<sup>2</sup>C and SMBus I/O Expander with Interrupt Output, RESET, I/O Direction Registers, and Programmable Pull-up/Pull-down

Check for Samples: [TCA7408](#)

## FEATURES

- Operating Power-Supply Voltage Range of 1.65V to 3.6V
- Allows Bidirectional Voltage-Level Translation and GPIO Expansion Between:
  - 1.8V SCL/SDA and 1.8V, 2.5V, 3.3V GPIO port
  - 2.5V SCL/SDA and 1.8V, 2.5V, 3.3V GPIO port
  - 3.3V SCL/SDA and 1.8V, 2.5V, 3.3V GPIO port
  - 5V SCL/SDA and 1.8V, 2.5V, 3.3V GPIO port
- Standby Current Consumption of <2  $\mu$ A at 1.8V
- Active Current Consumption of:
  - <2  $\mu$ A at 1.8V 100 kHz clock
  - <5  $\mu$ A at 1.8V 400 kHz clock
- 100-kHz, 400-kHz Fast Mode
- Internal Power-On-Reset and Watchdog Timer
- Fail safe I<sup>2</sup>C,  $\overline{\text{INT}}$ , and  $\overline{\text{RESET}}$  lines
- Noise Filter on SCL/SDA and Inputs
- Schmitt-Trigger Action Allows Slow Input Transition and Better Switching Noise Immunity at the SCL and SDA Inputs
  - $V_{\text{hys}} = 0.18\text{V}$  Typ at 1.8V
  - $V_{\text{hys}} = 0.25\text{V}$  Typ at 2.5V
  - $V_{\text{hys}} = 0.33\text{V}$  Typ at 3.3V
- Active-Low Reset ( $\overline{\text{RESET}}$ ) Input
- Open-Drain Active-Low Interrupt ( $\overline{\text{INT}}$ ) Output
- Automatic power save mode
- Programmable Pull-up/Pull-down Resistors for GPIO Inputs
- Programmable Edge Detection for Generating Interrupts
- Interrupt Latching
- Software Reset
- Input/Output Direction Register
- Power Up With All Channels Configured as Inputs
- No Glitch On Power Up
- Latched Outputs With High-Current Drive Maximum Capability for Directly Driving LEDs
- Latch-Up Performance Exceeds 100 mA Per JESD 78, Class II
- ESD Protection Exceeds JESD 22
  - 2000-V Human-Body Model (A114-A)
  - 1000-V Charged-Device Model (C101)

**ZSZ PACKAGE  
(TOP THROUGH VIEW)**

	1	2	3	4
A	GND	GPIO7	GPIO6	GPIO5
B	$V_{\text{CCI}}$	$V_{\text{CCP}}$	ADDR	GPIO4
C	SDA	$\overline{\text{INT}}$	$\overline{\text{RESET}}$	GPIO3
D	SCL	GPIO0	GPIO1	GPIO2

## DESCRIPTION

This 8-bit I/O expander for the two-line bidirectional bus (I<sup>2</sup>C) is designed to provide general-purpose remote I/O expansion via the I<sup>2</sup>C interface [serial clock (SCL) and serial data (SDA)].

The major benefit of this device is its wide  $V_{\text{CC}}$  range. It can operate from 1.65V to 3.6V on the GPIO-port side and 1.65V to 5.5V on the SDA/SCL side. This allows the TCA7408 to interface with next-generation microprocessors and microcontrollers on the SDA/SCL side, where supply levels are dropping down to conserve power.



Please be aware that an important notice concerning availability, standard warranty, and use in critical applications of Texas Instruments semiconductor products and disclaimers thereto appears at the end of this data sheet.



These devices have limited built-in ESD protection. The leads should be shorted together or the device placed in conductive foam during storage or handling to prevent electrostatic damage to the MOS gates.

## DESCRIPTION (CONTINUED)

The bidirectional voltage-level translation in the TCA7408 is provided through  $V_{CCI}$ .  $V_{CCI}$  should be connected to the  $V_{CC}$  of the external SCL/SDA lines. This indicates the  $V_{CC}$  level of the I<sup>2</sup>C bus to the TCA7408. The voltage level on the GPIO-port of the TCA7408 is determined by  $V_{CCP}$ .

At power on, the I/Os are configured as inputs. However, the system master can enable the I/Os as either inputs or outputs by writing to the I/O direction bits. The data for each input or output is kept in the corresponding Input or Output Register. All registers can be read by the system master.

The system master can reset the TCA7408 in the event of a timeout or other improper operation by asserting a low in the  $\overline{\text{RESET}}$  input. The power-on reset (POR) puts the registers in their default state and initializes the I<sup>2</sup>C/SMBus state machine. The  $\overline{\text{RESET}}$  pin causes the same reset/initialization to occur without depowering the part. The system master can also execute a software reset by asserting B0 in register 01h. The POR, and hardware reset events will reset the state machine and the registers to the default state. A software reset will only reset the registers to the default state and will not reset the state machine. In addition the watch dog timer only resets the state machine

The TCA7408 open-drain interrupt ( $\overline{\text{INT}}$ ) output is activated when any GPIO set as an input has a transition to the state opposite of that in the Input Default State (09h) register and the corresponding bit in the Interrupt Mask Register (11h) is set to 0. It is used to indicate to the system master that an input has changed to a pre-determined state.  $\overline{\text{INT}}$  is also activated after either a hardware reset or software reset. Watch dog timer does not activate the  $\overline{\text{INT}}$  pin.

$\overline{\text{INT}}$  can be connected to the interrupt input of a microcontroller. By sending an interrupt signal on this line, the remote I/O can inform the microcontroller if there is incoming data on its ports without having to communicate via the I<sup>2</sup>C bus. Thus, the TCA7408 can remain a simple slave device.

One hardware pin (ADDR) can be used to program the I<sup>2</sup>C address and allow up to two devices to share the same I<sup>2</sup>C bus or SMBus.

The integrated watchdog timer will reset the I<sup>2</sup>C state machine in the event the SDA is internally held low, after 200 ms (nominal). This reset does not reset the registers as they retain their previous value.

## ORDERING INFORMATION<sup>(1)</sup>

T <sub>A</sub>	PACKAGE <sup>(2)</sup>		ORDERABLE PART NUMBER	TOP-SIDE MARKING
-40°C to 85°C	μCSP – ZSZ package	Tape and reel	TCA7408ZSZR	ZUQ

(1) For the most current package and ordering information, see the Package Option Addendum at the end of this document, or see the TI web site at [www.ti.com](http://www.ti.com).

(2) Package drawings, thermal data, and symbolization are available at [www.ti.com/packaging](http://www.ti.com/packaging).

## DEVICE INFORMATION

### TOP THROUGH VIEW

	1	2	3	4
A	GND	GPIO7	GPIO6	GPIO5
B	V <sub>CCI</sub>	V <sub>CCP</sub>	ADDR	GPIO4
C	SDA	$\overline{\text{INT}}$	$\overline{\text{RESET}}$	GPIO3
D	SCL	GPIO0	GPIO1	GPIO2

### PIN FUNCTIONS

$\mu$ CSP (ZSZ)		DESCRIPTION
PIN NO.	NAME	
B1	VCCI	Supply voltage of I <sup>2</sup> C bus. Connect directly to the VCCI of the external I <sup>2</sup> C master. Provides voltage level translation.
B3	ADDR	Address input. Connect directly to V <sub>CCI</sub> or ground.
C3	$\overline{\text{RESET}}$	Active-low reset input. Connect to V <sub>CCI</sub> through a pull-up resistor, if no active connection is used.
D2	GPIO0	GPIO-port input/output (push-pull design structure). At power on, GPIO0 is configured as an input.
D3	GPIO1	GPIO-port input/output (push-pull design structure). At power on, GPIO1 is configured as an input.
D4	GPIO2	GPIO-port input/output (push-pull design structure). At power on, GPIO2 is configured as an input.
C4	GPIO3	GPIO-port input/output (push-pull design structure). At power on, GPIO3 is configured as an input.
A1	GND	Ground
B4	GPIO4	GPIO-port input/output (push-pull design structure). At power on, GPIO4 is configured as an input.
A4	GPIO5	GPIO-port input/output (push-pull design structure). At power on, GPIO5 is configured as an input.
A3	GPIO6	GPIO-port input/output (push-pull design structure). At power on, GPIO6 is configured as an input.
A2	GPIO7	GPIO-port input/output (push-pull design structure). At power on, GPIO7 is configured as an input.
C2	$\overline{\text{INT}}$	Active-low interrupt output. Connect to V <sub>CCI</sub> through a pull-up resistor.
D1	SCL	Serial clock bus. Connect to V <sub>CCI</sub> through a pull-up resistor.
C1	SDA	Serial data bus. Connect to V <sub>CCI</sub> through a pull-up resistor.
B2	VCCP	Supply voltage of TCA7408 for GPIO-port

### VOLTAGE TRANSLATION

V <sub>CCI</sub> (SCL AND SDA OF I <sup>2</sup> C MASTER) (V)	V <sub>CCP</sub> (GPIO-PORT) (V)
1.8	1.8
1.8	2.5
1.8	3.3
2.5	1.8
2.5	2.5
2.5	3.3
3.3	1.8
3.3	2.5
3.3	3.3
5	1.8
5	2.5
5	3.3



A Stop condition, a low-to-high transition on the SDA input/output while the SCL input is high, is sent by the master.

Any number of data bytes can be transferred from the transmitter to receiver between the Start and the Stop conditions. Each byte of eight bits is followed by one ACK bit. The transmitter must release the SDA line before the receiver can send an ACK bit. The device that acknowledges must pull down the SDA line during the ACK clock pulse, so that the SDA line is stable low during the high pulse of the ACK-related clock period. When a slave receiver is addressed, it must generate an ACK after each byte is received. Similarly, the master must generate an ACK after each byte that it receives from the slave transmitter. Setup and hold times must be met to ensure proper operation.

A master receiver signals an end of data to the slave transmitter by not generating an acknowledge (NACK) after the last byte has been clocked out of the slave. This is done by the master receiver by holding the SDA line high. In this event, the transmitter must release the data line to enable the master to generate a Stop condition.

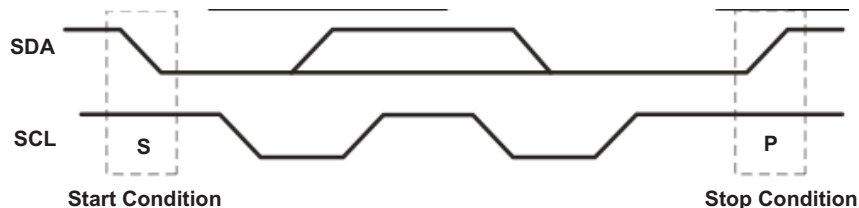

Figure 1. Definition of Start and Stop Conditions

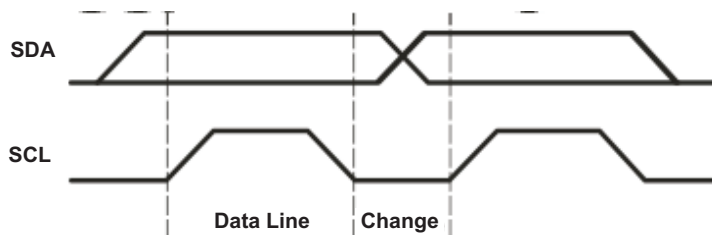

Figure 2. Bit Transfer

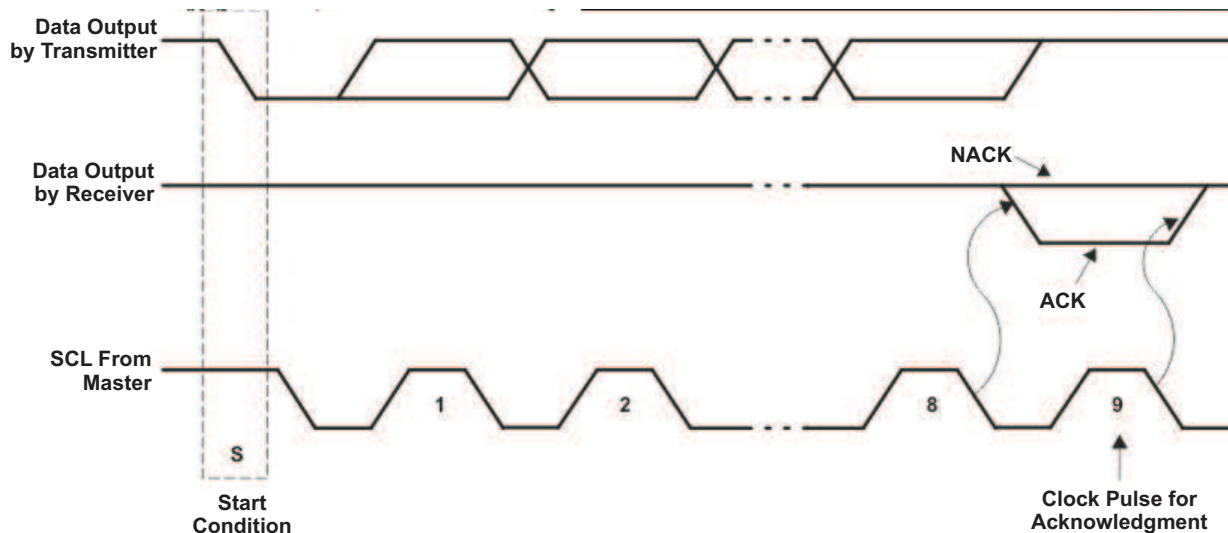

Figure 3. Acknowledgment on I<sup>2</sup>C Bus

# TCA7408

SCPS235B –NOVEMBER 2011–REVISED MARCH 2013

www.ti.com

## DEVICE ADDRESS

The address of the device is shown below

### ADDRESS REFERENCE

ADDR	SLAVE ADDRESS								I <sup>2</sup> C BUS SLAVE ADDRESS
	B7	B6	B5	B4	B3	B2	B1	B0	
0	1	0	0	0	0	1	1	0 (W)	134 (decimal), 86(h)
0	1	0	0	0	0	1	1	1 (R)	135 (decimal), 87(h)
1	1	0	0	0	1	0	0	0 (W)	136 (decimal), 88(h)
1	1	0	0	0	1	0	0	1 (R)	137 (decimal), 89(h)

The last bit of the slave address defines the operation (read or write) to be performed. A high (1) selects a read operation, while a low (0) selects a write operation.

## CONTROL REGISTER AND COMMAND BYTE

Following the successful acknowledgement of the address byte, the bus master sends a command byte, which is stored in the Control Register in the TCA7408. Five bits of this data byte state the operation (read or write) and the internal registers that will be affected. This register can be written or read through the I<sup>2</sup>C bus. The command byte is sent only during a write transmission.

## AUTO INCREMENT MODE

An automatic increment feature has been added to the control register for block writes. The master can write to all 10 registers with 1 command byte being sent initially. In auto-increment mode the last five bits of the command byte are automatically incremented after the byte is written and the next data byte is stored in the corresponding register. Registers are written in the order shown in the register map shown below. Writes attempted to read only registers do not change the value in the register.

If B7=0, all the data bytes are written to or read from the register defined by B4 through B0 in a non-incremented fashion. B6 and B5 should always be 0.

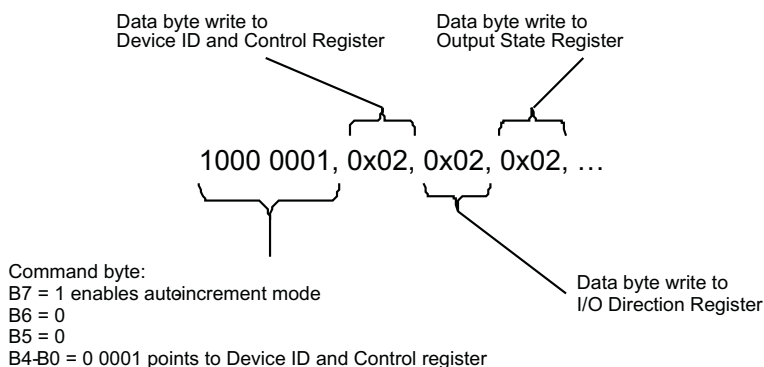

## REGISTER MAP

CONTROL REGISTER BITS								COMMAND BYTE (HEX)	REGISTER	PROTOCOL	POWER-UP DEFAULT
B7	B6	B5	B4	B3	B2	B1	B0				
AI	0	0	0	0	0	0	1	01h	Device ID and Control	Read (B7-B1) Write (B0)	0100 0010
AI	0	0	0	0	0	1	1	03h	I/O Direction	Read/write byte	0000 0000
AI	0	0	0	0	1	0	1	05h	Output State	Read/write byte	0000 0000
AI	0	0	0	0	1	1	1	07h	Output High-Impedance	Read/write byte	1111 1111
AI	0	0	0	1	0	0	1	09h	Input Default State	Read/write byte	0000 0000
AI	0	0	0	1	0	1	1	0Bh	Pull-up/down Enable	Read/write byte	1111 1111
AI	0	0	0	1	1	0	1	0Dh	Pull-up/down Select	Read/write byte	0000 0000
AI	0	0	0	1	1	1	1	0Fh	Input Status	Read byte	xxxx xxxx
AI	0	0	1	0	0	0	1	11h	Interrupt Mask	Read/write byte	0000 0000
AI	0	0	1	0	0	1	1	13h	Interrupt Status	Read byte	0000 0000

## REGISTER DESCRIPTIONS

### Register 01h – Device ID and Control

The Device ID and Control register contains the manufacturer ID and firmware revision. The Control register indicates whether the device has been reset and the default values have been set.

- The Reset Interrupt is set B1=1 when the device is either reset by the  $\overline{\text{RESET}}$  pin, a power on reset, or software reset.
- Reset Interrupt is then cleared after being read by the master.
- Writing to B7–B1 has no effect on these bits in the register.
- A software reset is issued when the master writes B0=1.
- When reading from B0, the value read will always be 0.

BIT	B7	B6	B5	B4	B3	B2	B1	B0
DESCRIPTION	Manufacturer ID			Firmware Revision			Reset Interrupt	Software Reset
DEFAULT	0	1	0	0	0	0	1	0

### Register 03h – I/O Direction

The I/O Direction Register configures the direction of the I/O pins.

- If a bit in this register is set to 0, the corresponding port pin is enabled as an input
- If a bit in this register is set to 1, the corresponding port pin is enabled as an output.
- When the port is set as an output the input buffers are disabled such that the bus can float.

BIT	B7	B6	B5	B4	B3	B2	B1	B0
DESCRIPTION	GPIO7	GPIO6	GPIO5	GPIO4	GPIO3	GPIO2	GPIO1	GPIO0
DEFAULT	0	0	0	0	0	0	0	0

### Register 05h – Output Port Register

The Output Port Register sets the outgoing logic levels of the pins defined as outputs.

- When Bx is set to 0, GPIOx = L
- When Bx is set to 1, GPIOx = H
- Bit values in this register have no effect on pins defined as inputs
- Reads from this register reflect the value that is in the flip-flop controlling the output selection, not the actual pin value.

BIT	B7	B6	B5	B4	B3	B2	B1	B0
DESCRIPTION	GPIO7	GPIO6	GPIO5	GPIO4	GPIO3	GPIO2	GPIO1	GPIO0
DEFAULT	0	0	0	0	0	0	0	0

# TCA7408

SCPS235B –NOVEMBER 2011–REVISED MARCH 2013

[www.ti.com](http://www.ti.com)

## Register 07h – Output High-Impedance

The Output High-Impedance Register determines whether pins set as output are enabled or high-impedance

- When a bit in this register is set to 0, the corresponding GPIO-port output state follows register the output port register (05h).
- When a bit in this register is set to 1, the corresponding GPIO-port output is set to high-impedance.
- Bit values in this register have no effect on pins defined as inputs. In turn, reads from this register reflect the value that is in the flip-flop controlling the output selection, not the actual pin value.

BIT	B7	B6	B5	B4	B3	B2	B1	B0
DESCRIPTION	GPIO7	GPIO6	GPIO5	GPIO4	GPIO3	GPIO2	GPIO1	GPIO0
DEFAULT	1	1	1	1	1	1	1	1

## Register 09h – Input Default State

The Input Default State Register sets the default state of the GPIO-port input for generating interrupts.

- When a bit in this register is set to 0, the default for the corresponding input is set to LOW
- When a bit in this register is set to 1, the default for the corresponding input is set to HIGH
- Bit values in this register have no effect on pins defined as outputs. In turn, reads from this register reflect the value that is in the flip-flop controlling the default state, not the actual pin value.

BIT	B7	B6	B5	B4	B3	B2	B1	B0
DESCRIPTION	GPIO7	GPIO6	GPIO5	GPIO4	GPIO3	GPIO2	GPIO1	GPIO0
DEFAULT	1	1	1	1	1	1	1	1

## Register 0Bh – Pull-up/-down Enable

The Pull-up/-down Enable Register enables or disables the pull-up/down resistor on the GPIO-port as defined in the Pull-up/down Select Register (0Dh).

- When a bit in this register is set to 0, the pull-up/down on the corresponding GPIO is disabled.
- When a bit in this register is set to 1, the pull-up/down on the corresponding GPIO is enabled.

BIT	B7	B6	B5	B4	B3	B2	B1	B0
DESCRIPTION	GPIO7	GPIO6	GPIO5	GPIO4	GPIO3	GPIO2	GPIO1	GPIO0
DEFAULT	1	1	1	1	1	1	1	1

## Register 0Dh – Pull-up/-down Select

The Pull-up/down Select Register allows the user to select either a pull-up or pull-down on the GPIO-port. This register only selects the pull-up/down resistor on the GPIO-port, while the enabling/disabling is controlled by the Pull-up/down Enable Register (0Bh).

- When a bit in this register is set to 0, the pull-down on the corresponding GPIO is selected.
- When a bit in this register is set to 1, the pull-up on the corresponding GPIO is selected.

BIT	B7	B6	B5	B4	B3	B2	B1	B0
DESCRIPTION	GPIO7	GPIO6	GPIO5	GPIO4	GPIO3	GPIO2	GPIO1	GPIO0
DEFAULT	0	0	0	0	0	0	0	0

### Register 0Fh – Input Status Register

The Input Status Register reflects the incoming logic levels of the GPIOs set as inputs.

- The default value, X, is determined by the externally applied logic level.
- It only acts on read operation. Attempted writes to this register have no effect.
- For GPIOs set as outputs this register will read HIGH.

BIT	B7	B6	B5	B4	B3	B2	B1	B0
DESCRIPTION	GPIO7	GPIO6	GPIO5	GPIO4	GPIO3	GPIO2	GPIO1	GPIO0
DEFAULT	X	X	X	X	X	X	X	X

### Register 11h – Interrupt Mask Register

The Interrupt Mask Register controls the generation of an interrupt to the  $\overline{\text{INT}}$  pin when the GPIO-port input state changes state.

- When a bit in this register is set to 0, an interrupt generated by the interrupt status register causes the  $\overline{\text{INT}}$  pin to be asserted LOW.
- When a bit in this register is set to 1, the interrupt for the corresponding GPIO is disabled. The corresponding bit in the Interrupt Status Register (13h) will still be asserted.
- $\overline{\text{INT}}$  is not affected when GPIO-port is defined as outputs.

BIT	B7	B6	B5	B4	B3	B2	B1	B0
DESCRIPTION	GPIO7	GPIO6	GPIO5	GPIO4	GPIO3	GPIO2	GPIO1	GPIO0
DEFAULT	0	0	0	0	0	0	0	0

### Register 13h – Interrupt Status Register

The Interrupt Status Register bit is asserted when the bit changes to a value opposite to the default value defined in the Input Default State Register (09h).

- This bit is cleared and the  $\overline{\text{INT}}$  pin is de-asserted upon read of this register.
- The input must be asserted back to the default state before this bit is set again.
- If the GPIO-port pin is defined as an output, this bit is never set.
- Attempted writes to this register, have no effect.

BIT	B7	B6	B5	B4	B3	B2	B1	B0
DESCRIPTION	GPIO7	GPIO6	GPIO5	GPIO4	GPIO3	GPIO2	GPIO1	GPIO0
DEFAULT	0	0	0	0	0	0	0	0

## POWER-ON RESET

When power (from 0V) is applied to  $V_{CCP}$ , an internal power-on reset holds the TCA7408 in a reset condition until  $V_{CCP}$  has reached  $V_{POR}$ . At that time, the reset condition is released, and the TCA7408 registers and I<sup>2</sup>C/SMBus state machine initialize to their default states. After that,  $V_{CCP}$  must be lowered to below  $V_{PORF}$  and back up to the operating voltage for a power-reset cycle.

- During power up, if  $V_{CCI}$  ramps before  $V_{CCP}$ , a power on reset event occurs and the I<sup>2</sup>C registers are reset.
- If  $V_{CCP}$  ramps up before  $V_{CCI}$ , then the device with reset as if  $\overline{\text{RESET}} = 0$
- The device is reset regardless of which  $V_{CCx}$  ramps first.

## RESET ( $\overline{\text{RESET}}$ ) INPUT

The  $\overline{\text{RESET}}$  input can be asserted to initialize the system while keeping  $V_{CCP}$  at its operating level. A reset can be accomplished by holding the  $\overline{\text{RESET}}$  pin low for a minimum of  $t_W$ . The TCA7408 registers and I<sup>2</sup>C/SMBus state machine are changed to their default state once  $\overline{\text{RESET}}$  is low (0). Only when  $\overline{\text{RESET}}$  is high (1), GPIO registers can be accessed by the I<sup>2</sup>C pin. This input requires a pull-up resistor to  $V_{CCI}$ , if no active connection is used.

## INTERRUPT ( $\overline{\text{INT}}$ ) OUTPUT

An interrupt is generated by a rising or falling edge of the port inputs in the input mode. After time  $t_{IV}$ , the signal  $\overline{\text{INT}}$  is valid. Resetting the interrupt circuit is achieved by reading the Interrupt Status Register. Resetting occurs in the read mode at the acknowledge (ACK) or not acknowledge (NACK) bit after the rising edge of the SCL signal. Each change of the I/Os after resetting is detected and is transmitted as  $\overline{\text{INT}}$ . The values in the interrupt status register are sampled on the rising edge of SCL during the read address acknowledge. If an interrupt occurs before this event, it will be reflected in this register in the next read cycle. If an interrupt occurs very close to this event, it may be reflected in both the current and the next read cycle. At no point is a valid interrupt ever missed.

Reading from or writing to another device does not affect the interrupt circuit, and a pin configured as an output cannot cause an interrupt. Changing an I/O from an output to an input may cause a false interrupt to occur, if the state of the pin does not match the contents of the Input Default State Register.

The  $\overline{\text{INT}}$  output has an open-drain structure and requires a pullup resistor to  $V_{CCP}$  or  $V_{CCI}$  depending on the application.  $\overline{\text{INT}}$  should be connected to the voltage source of the device that requires the interrupt information.

## BUS TRANSACTIONS

Data is exchanged between the master and TCA7408 through write and read commands.

### Writes

Data is transmitted to the TCA7408 by sending the device address and setting the least significant bit (LSB) to a logic 0. The command byte is sent after the address and determines which register receives the data that follows the command byte. There is no limitation on the number of data bytes sent in one write transmission.

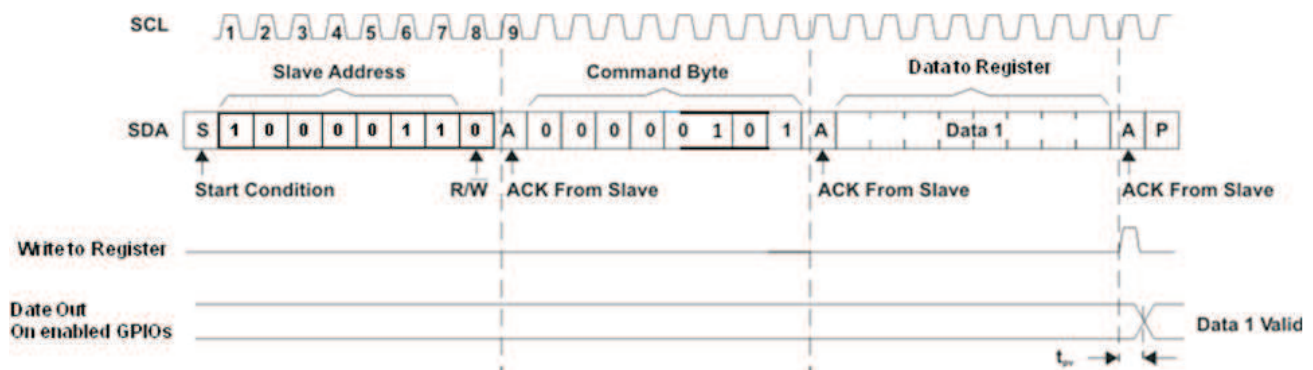

Figure 4. Write to Output state Register (Note: ADDR = 0)

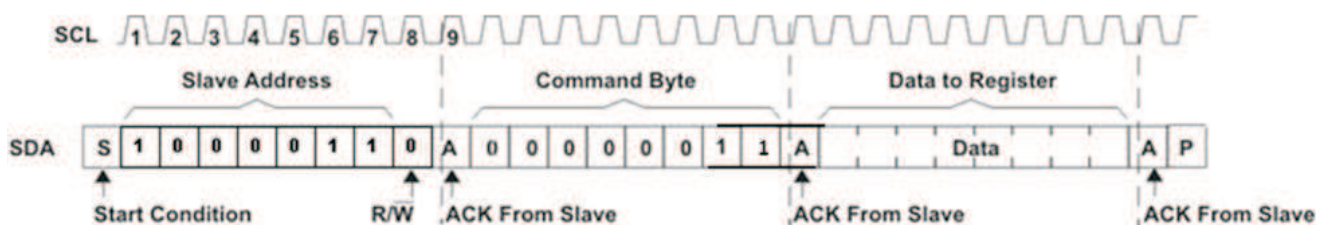

Figure 5. Write to I/O Direction Register (Note: ADDR = 0)

**Reads**

The bus master first must send the TCA7408 address with the LSB set to a logic 0. The command byte is sent after the address and determines which register is accessed.

After a restart, the device address is sent again but, this time, the LSB is set to a logic 1. Data from the register defined by the command byte then is sent by the TCA7408.

Data is clocked into the register on the rising edge of the ACK clock pulse.

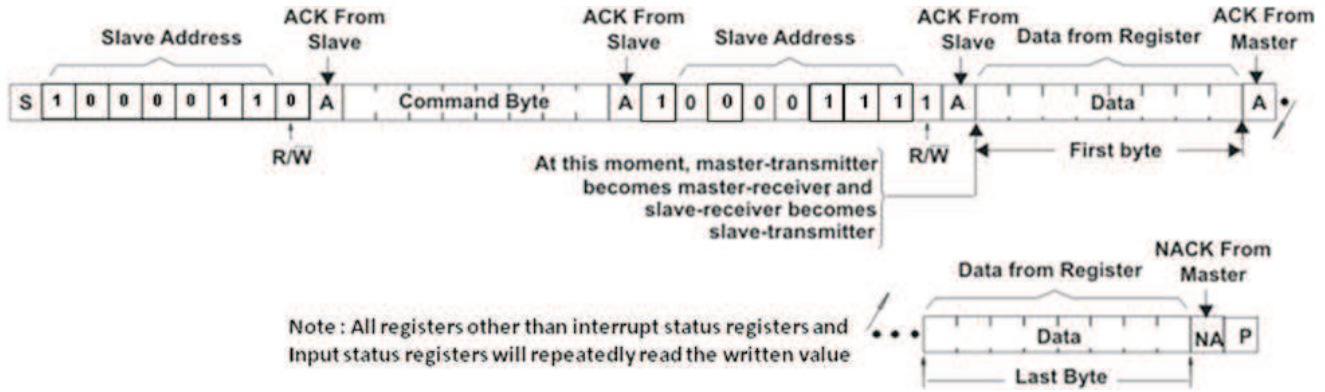

**Figure 6. Read From Register**

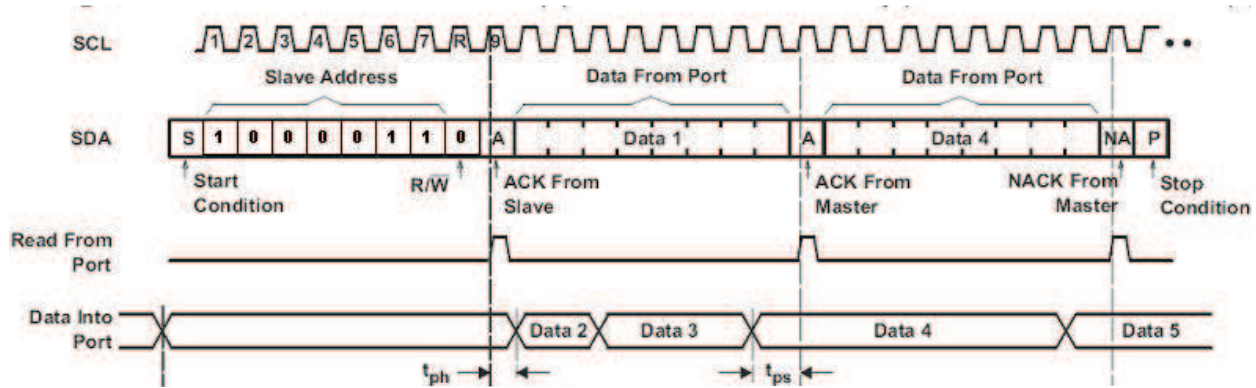

NOTE: ADDR = 0

**Figure 7. Read From Input Status Register**

Transfer of data can be stopped at any time by a Stop condition. When this occurs, data present at the latest acknowledge phase is valid (output mode). It is assumed that the command byte previously has been set to 0Fh (read Input Status Register). This figure eliminates the command byte transfer, a restart, and slave address call between the initial slave address call and actual data transfer from GPIO.

# TCA7408

SCPS235B – NOVEMBER 2011 – REVISED MARCH 2013

[www.ti.com](http://www.ti.com)

## ABSOLUTE MAXIMUM RATINGS<sup>(1)(2)(3)</sup>

				MIN	MAX	UNIT
$V_{CCI}$	Supply voltage range			-0.3	6	V
$V_{CCP}$				-0.3	4	
$V_I$	Input voltage range			-0.3	6	V
$V_O$	Output voltage range			-0.3	6	V
$I_{IK}$	Input clamp current	ADDR, $\overline{\text{RESET}}$ , SCL	$V_I < 0$		$\pm 20$	mA
$I_{OK}$	Output clamp current	INT	$V_O < 0$		$\pm 20$	mA
$I_{IOK}$	Input/output clamp current	GPIO port	$V_O < 0$ or $V_O > V_{CCP}$		$\pm 20$	mA
		SDA	$V_O < 0$ or $V_O > V_{CCI}$		$\pm 20$	
$I_{OL}$	Continuous output low current	GPIO port	$V_O = 0$ to $V_{CCP}$		10	mA
		SDA, $\overline{\text{INT}}$	$V_O = 0$ to $V_{CCI}$		10	
$I_{OH}$	Continuous output high current	GPIO port	$V_O = 0$ to $V_{CCP}$		10	mA
$I_{CC}$	Continuous current through GND				200	mA
	Continuous current through $V_{CCP}$				160	
	Continuous current through $V_{CCI}$				10	
$\theta_{JA}$	Package thermal impedance	ZSZ package		TBD		$^{\circ}\text{C/W}$
$T_{stg}$	Storage temperature range			-65	150	$^{\circ}\text{C}$

- (1) Stresses beyond those listed under "absolute maximum ratings" may cause permanent damage to the device. These are stress ratings only, and functional operation of the device at these or any other conditions beyond those indicated under "recommended operating conditions" is not implied. Exposure to absolute-maximum-rated conditions for extended periods may affect device reliability.
- (2) The input negative-voltage and output voltage ratings may be exceeded if the input and output current ratings are observed.
- (3) The package thermal impedance is calculated in accordance with JESD 51-7.

## RECOMMENDED OPERATING CONDITIONS

				MIN	MAX	UNIT
$V_{CCI}$	Supply voltage			1.65	5.5	V
$V_{CCP}$				1.65	3.6	
$V_{IH}$	High-level input voltage	SCL, SDA	$0.7 \times V_{CCI}$	5.5	V	
		$\overline{\text{RESET}}$ , ADDR	$0.65 \times V_{CCI}$	5.5		
		GPIO7–GPIO0	$0.65 \times V_{CCP}$	3.6		
$V_{IL}$	Low-level input voltage	SCL, SDA	-0.3	$0.3 \times V_{CCI}$	V	
		$\overline{\text{RESET}}$ , ADDR	-0.3	$0.35 \times V_{CCI}$		
		GPIO7–GPIO0	-0.3	$0.35 \times V_{CCP}$		
$I_{OH}$	High-level output current	GPIO7–GPIO0		10	mA	
$I_{OL}$	Low-level output current	GPIO7–GPIO0		10	mA	
$T_A$	Operating free-air temperature			-40	85	$^{\circ}\text{C}$

**ELECTRICAL CHARACTERISTICS**

PARAMETER		TEST CONDITIONS	V <sub>CCI</sub>	V <sub>CCP</sub>	MIN	TYP	MAX	UNIT
V <sub>IK</sub>	Input diode clamp voltage	I <sub>I</sub> = -18 mA	1.65 V to 5.5 V	1.65 V to 3.6 V	-1.2			V
V <sub>POR</sub>	Power-on reset voltage <sup>(1)</sup>	V <sub>I</sub> = V <sub>CCP</sub> or GND, I <sub>O</sub> = 0	1.65 V to 3.6 V	1.65 V to 3.6 V		1	1.4	V
V <sub>OH</sub>	GPIO-port high-level output voltage	I <sub>OH</sub> = -6 mA	1.65 V	1.65 V	1.2			V
			2.3 V	2.3 V	1.8			
			3 V	3 V	2.6			
		I <sub>OH</sub> = -10 mA	1.65 V	1.65 V	1.1			V
			2.3 V	2.3 V	1.7			
			3 V	3 V	2.5			
V <sub>OL</sub>	GPIO-port low-level output voltage	I <sub>OL</sub> = 6 mA	1.65 V	1.65 V			0.45	V
			2.3 V	2.3 V			0.25	
			3 V	3 V			0.25	
		I <sub>OL</sub> = 10 mA	1.65 V	1.65 V			0.6	V
			2.3 V	2.3 V			0.3	
			3 V	3 V			0.25	
I <sub>OL</sub>	SDA <sup>(2)</sup>	V <sub>OL</sub> = 0.4 V	1.65 V to 5.5 V	1.65 V to 3.6 V	10			mA
	INT		2.3 to 5.5 V	2.3 to 3.6 V	20			
			1.65 V to 5.5 V	1.65 V to 3.6 V	3			
I <sub>I</sub>	SCL, SDA, RESET, ADDR	V <sub>I</sub> = V <sub>CCI</sub> or GND	1.65 V to 5.5 V	1.65 V to 3.6 V			±0.1	μA
		V <sub>I</sub> = V <sub>CCP</sub> or GND					±0.1	
I <sub>IH</sub>	GPIO port	V <sub>I</sub> = V <sub>CCP</sub>	1.65 V to 5.5 V	1.65 V to 3.6 V			1	μA
I <sub>IL</sub>		V <sub>I</sub> = GND					1	

- (1) When power (from 0 V) is applied to V<sub>CCP</sub>, an internal power-on reset holds the TCA7408 in a reset condition until V<sub>CCP</sub> has reached V<sub>POR</sub>. At that time, the reset condition is released, and the TCA7408 registers and I<sup>2</sup>C/SMBus state machine initialize to their default states. After that, V<sub>CCP</sub> must be lowered to below 0.2 V and back up to the operating voltage for a power-reset cycle.
- (2) I<sub>OL</sub> for SDA is specified for standard mode, fast mode, and fast mode plus capability (at 2.3 V).

**ELECTRICAL CHARACTERISTICS (Continued)**

PARAMETER		TEST CONDITIONS	V <sub>CCI</sub>	V <sub>CCP</sub>	MIN	TYP <sup>(1)</sup>	MAX	UNIT
I <sub>CC</sub> (I <sub>CCI</sub> + I <sub>CCP</sub> )	Fast Mode Operating mode	SDA, GPIO port, ADDR, RESET	V <sub>I</sub> on SDA, ADDR, and RESET = V <sub>CCI</sub> or GND, V <sub>I</sub> on GPIO port = V <sub>CCP</sub> or GND, I <sub>O</sub> = 0, I/O = inputs, f <sub>SCL</sub> = 400 kHz	3.6 V to 5.5 V	3.6 V	4	9	μA
				2.3 V to 3.6 V	2.3 V to 3.6 V	6.5	15	
				1.65 V to 2.3 V	1.65 V to 2.3 V	10	20	
	Standby mode	SCL, SDA, GPIO port, ADDR, RESET	V <sub>I</sub> on SCL, SDA and RESET = V <sub>CCI</sub> or GND, V <sub>I</sub> on GPIO port and ADDR = V <sub>CCI</sub> or GND, I <sub>O</sub> = 0, I/O = inputs, f <sub>SCL</sub> = 0	3.6 V to 5.5 V	3.6 V	1.5	7	μA
				2.3 V to 3.6 V	2.3 V to 3.6 V	1	3.2	
				1.65 V to 2.3 V	1.65 V to 2.3 V	0.5	1.7	
ΔI <sub>CCI</sub>	Additional current in standby mode	SCL, SDA, RESET	One input at V <sub>CCI</sub> - 0.6 V, Other inputs at V <sub>CCI</sub> or GND	1.65 V to 5.5 V	1.65 V to 3.6 V		25	μA
ΔI <sub>CCP</sub>		GPIO port, ADDR	One input at V <sub>CCP</sub> - 0.6 V, Other inputs at V <sub>CCP</sub> or GND	1.65 V to 5.5 V	1.65 V to 3.6 V		80	μA
C <sub>I</sub>	SCL	V <sub>I</sub> = V <sub>CCI</sub> or GND	1.65 V to 5.5 V	1.65 V to 3.6 V	6			pF
C <sub>IO</sub>	SDA	V <sub>IO</sub> = V <sub>CCI</sub> or GND	1.65 V to 5.5 V	1.65 V to 3.6 V	7			pF
	GPIO port	V <sub>IO</sub> = V <sub>CCP</sub> or GND			7.5			
R <sub>PU</sub>	Pull up resistor	V <sub>I</sub> = GND	1.65 V to 5.5 V	1.65 V to 3.6 V	100			kΩ
R <sub>PD</sub>	Pull down resistor	V <sub>I</sub> = V <sub>CCP</sub>	1.65 V to 5.5 V	1.65 V to 3.6 V	100			kΩ

- (1) All typical values are at nominal supply voltage (1.8V, 2.5V, 3.3V, or 5V VCC) and T<sub>A</sub> = 25°C.

**I<sup>2</sup>C INTERFACE TIMING REQUIREMENTS**

PARAMETER		STANDARD MODE I <sup>2</sup> C BUS		FAST MODE I <sup>2</sup> C BUS		UNIT
		MIN	MAX	MIN	MAX	
f <sub>SCL</sub>	I <sup>2</sup> C clock frequency	0	100	0	400	kHz
t <sub>SCH</sub>	I <sup>2</sup> C clock high time	4		0.6		μs
t <sub>SCL</sub>	I <sup>2</sup> C clock low time	4.7		1.3		μs
t <sub>SP</sub>	I <sup>2</sup> C spike time		50		50	ns

**I2C INTERFACE TIMING REQUIREMENTS (continued)**

PARAMETER	STANDARD MODE I <sup>2</sup> C BUS		FAST MODE I <sup>2</sup> C BUS		UNIT
	MIN	MAX	MIN	MAX	
t <sub>sds</sub> I <sup>2</sup> C serial data setup time	250		100		ns
t <sub>sdh</sub> I <sup>2</sup> C serial data hold time	0		0		ns
t <sub>icr</sub> I <sup>2</sup> C input rise time		1000	20 + 0.1C <sub>b</sub>	300	ns
t <sub>icf</sub> I <sup>2</sup> C input fall time		300	20 + 0.1C <sub>b</sub>	300	ns
t <sub>ocf</sub> I <sup>2</sup> C output fall time; 10 pF to 400 pF bus		300	20 + 0.1C <sub>b</sub>	300	μs
t <sub>buf</sub> I <sup>2</sup> C bus free time between Stop and Start	4.7		1.3		μs
t <sub>sts</sub> I <sup>2</sup> C Start or repeater Start condition setup time	4.7		0.6		μs
t <sub>sth</sub> I <sup>2</sup> C Start or repeater Start condition hold time	4		0.6		μs
t <sub>sps</sub> I <sup>2</sup> C Stop condition setup time	4		0.6		μs
t <sub>vd(data)</sub> Valid data time; SCL low to SDA output valid		1	0.3	0.9	μs
t <sub>vd(ack)</sub> Valid data time of ACK condition; ACK signal from SCL low to SDA (out) low		1	0.3	0.9	μs

**RESET TIMING REQUIREMENTS**

PARAMETER	STANDARD MODE, FAST MODE, I <sup>2</sup> C BUS		UNIT
	MIN	MAX	
t <sub>w</sub> Reset pulse duration	250		ns
t <sub>REC</sub> Reset recovery time	250		ns
t <sub>RESET</sub> Time to reset	250		ns

**SWITCHING CHARACTERISTICS**

PARAMETER	FROM (INPUT)	TO (OUTPUT)	STANDARD MODE, FAST MODE, I <sup>2</sup> C BUS		UNIT
			MIN	MAX	
t <sub>iv</sub> Interrupt valid time	GPIO port	INT		20	ns
t <sub>ir</sub> Interrupt reset delay time	SCL	INT		250	ns
t <sub>pV</sub> Output data valid	SCL	GPIO7–GPIO0		250	ns
t <sub>ps</sub> Input data setup time	GPIO port	SCL	0		ns
t <sub>ph</sub> Input data hold time	GPIO port	SCL	300		ns

PARAMETER MEASUREMENT INFORMATION

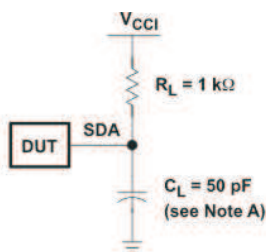

SDA LOAD CONFIGURATION

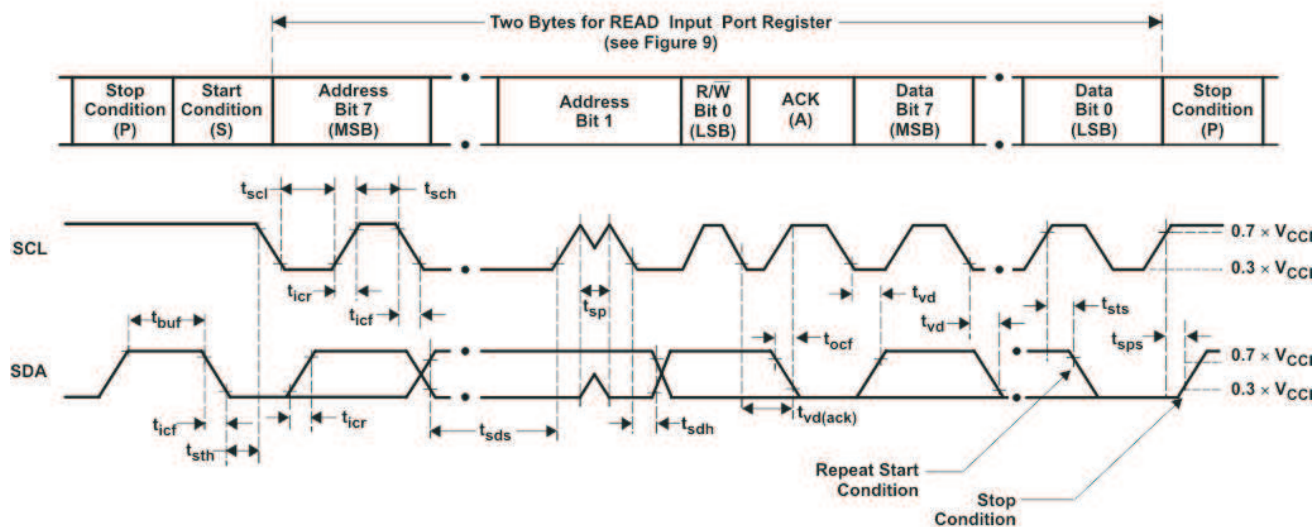

VOLTAGE WAVEFORMS

BYTE	DESCRIPTION
1	I <sup>2</sup> C address
2	Input register port data

NOTE:  $C_L$  includes probe and jig capacitance.  $t_{ocf}$  is measured with  $C_L$  of 10 pF or 400 pF. All inputs are supplied by generators having the following characteristics: PRR  $\leq$  10 MHz,  $Z_O = 50\ \Omega$ ,  $t_r/t_f \leq 30\text{ ns}$ . All parameters and waveforms are not applicable to all devices.

Figure 8. I<sup>2</sup>C Interface Load Circuit and Voltage Waveforms

PARAMETER MEASUREMENT INFORMATION (continued)

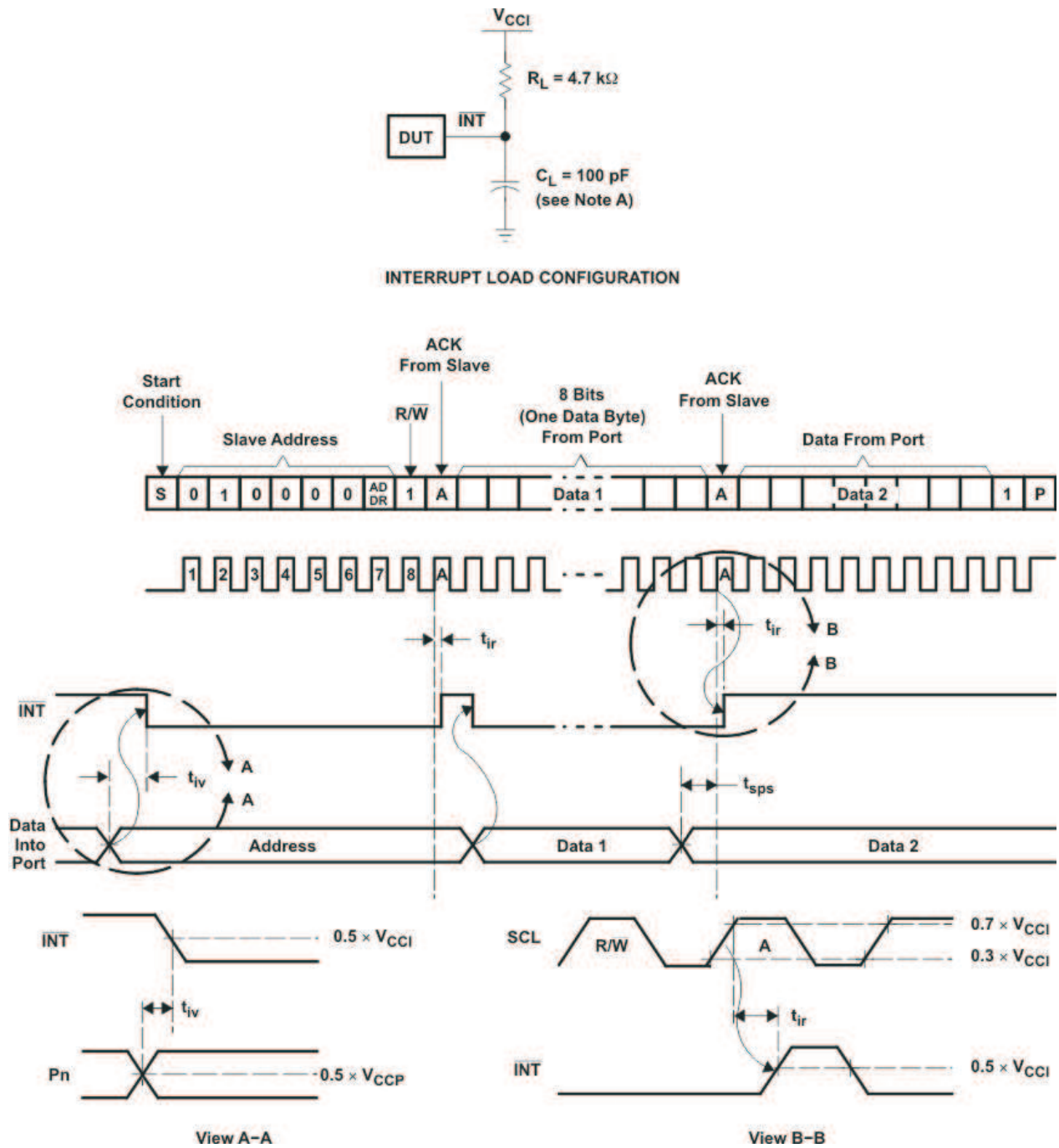

NOTE: C<sub>L</sub> includes probe and jig capacitance. All inputs are supplied by generators having the following characteristics: PRR ≤ 10 MHz, Z<sub>O</sub> = 50 Ω, t<sub>r</sub>/t<sub>f</sub> ≤ 30 ns. All parameters and waveforms are not applicable to all devices.

Figure 9. Interrupt Load Circuit and Voltage Waveforms

PARAMETER MEASUREMENT INFORMATION (continued)

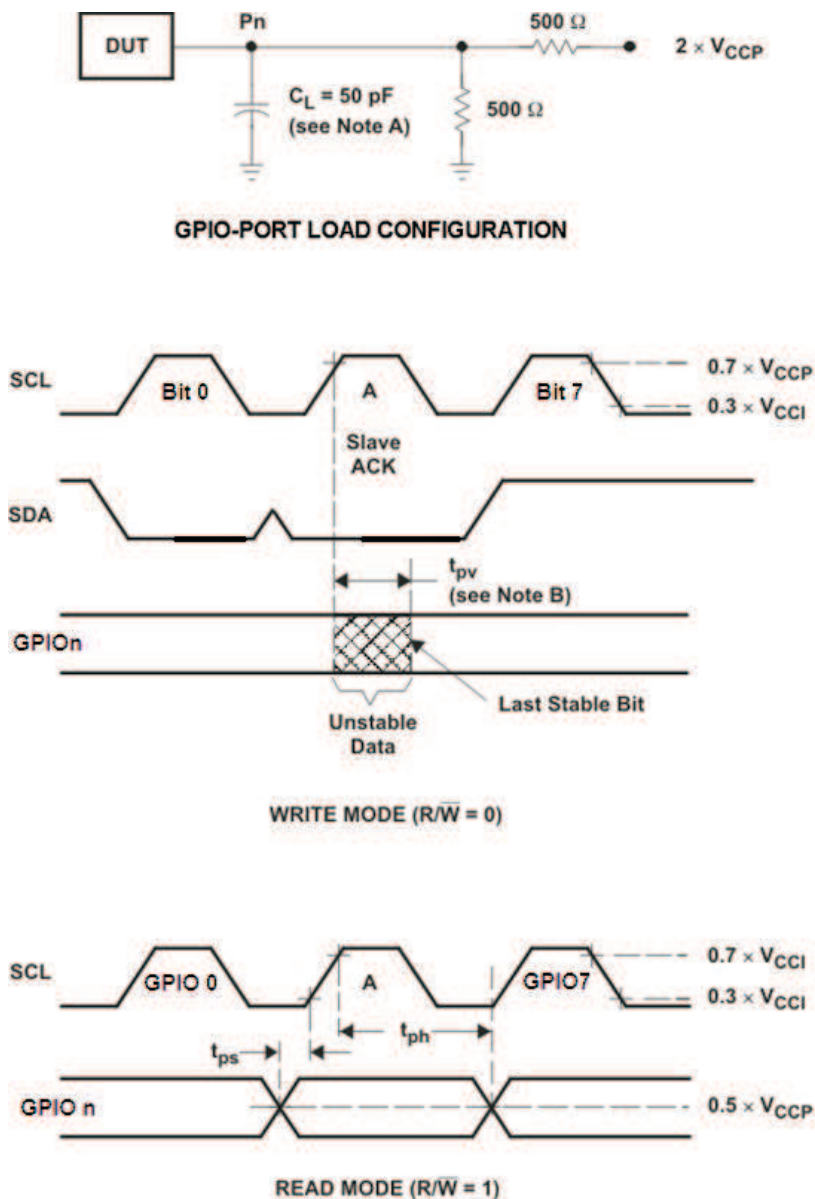

NOTE:  $C_L$  includes probe and jig capacitance.  $t_{pv}$  is measured from  $0.7 \times V_{CC}$  on SCL to 50% I/O ( $P_n$ ) output. All inputs are supplied by generators having the following characteristics: PRR  $\leq$  10 MHz,  $Z_O = 50 \Omega$ ,  $t_r/t_f \leq 30$  ns. The outputs are measured one at a time, with one transition per measurement. All parameters and waveforms are not applicable to all devices.

Figure 10. GPIO-port Load Circuit and Timing Waveforms

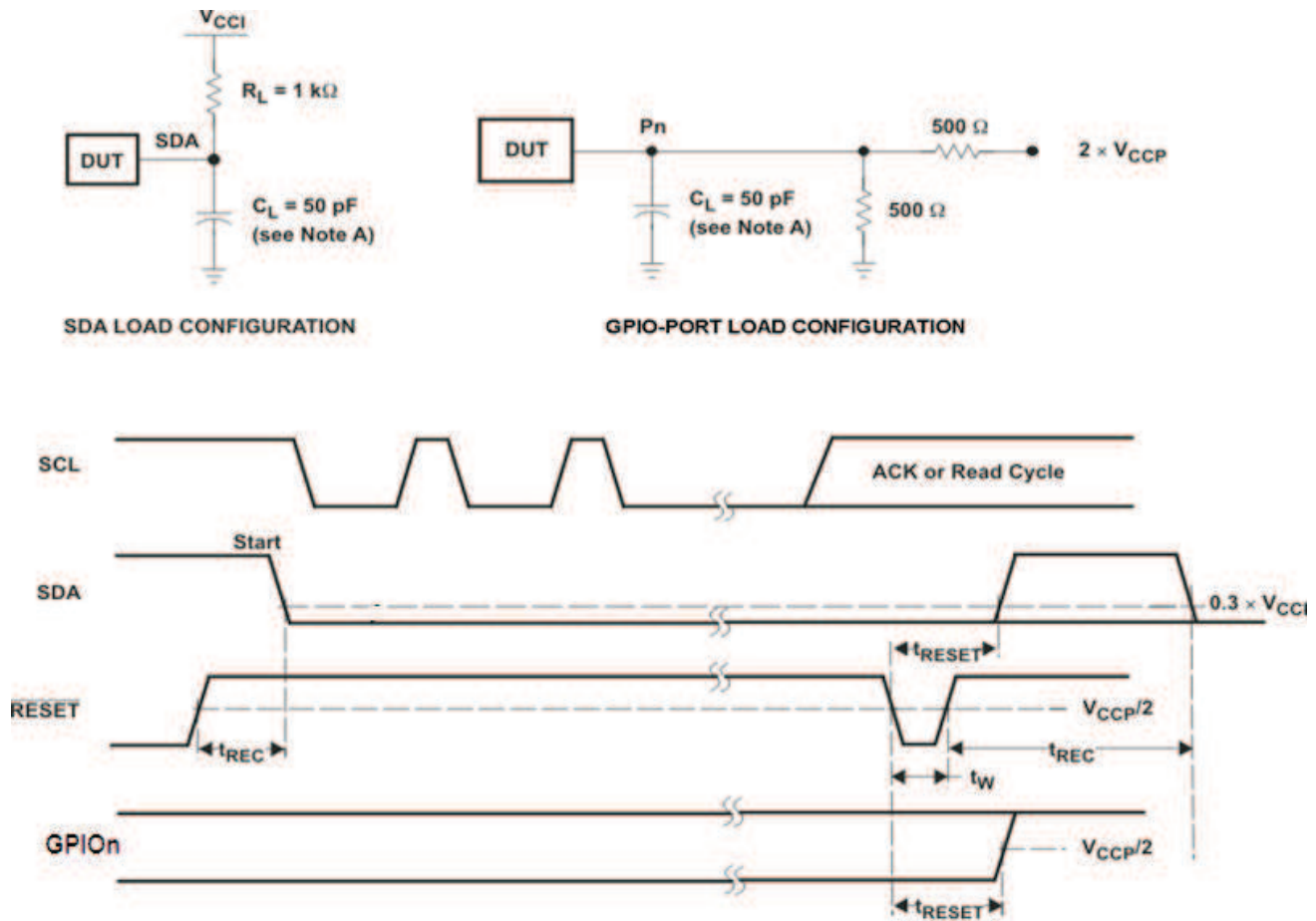
**PARAMETER MEASUREMENT INFORMATION (continued)**

NOTE:  $C_L$  includes probe and jig capacitance. All inputs are supplied by generators having the following characteristics: PRR  $\leq 10$  MHz,  $Z_O = 50 \Omega$ ,  $t_r/t_f \leq 30$  ns. The outputs are measured one at a time, with one transition per measurement. I/Os are configured as inputs. All parameters and waveforms are not applicable to all devices.

**Figure 11. Reset Load Circuits and Voltage Waveforms**

## APPLICATION INFORMATION

### POWER-ON RESET REQUIREMENTS

In the event of a glitch or data corruption, TCA7408 can be reset to its default conditions by using the power-on reset feature. Power-on reset requires that the device go through a power cycle to be completely reset. This reset also happens when the device is powered on for the first time in an application.

The two types of power-on reset are shown in the figures below:

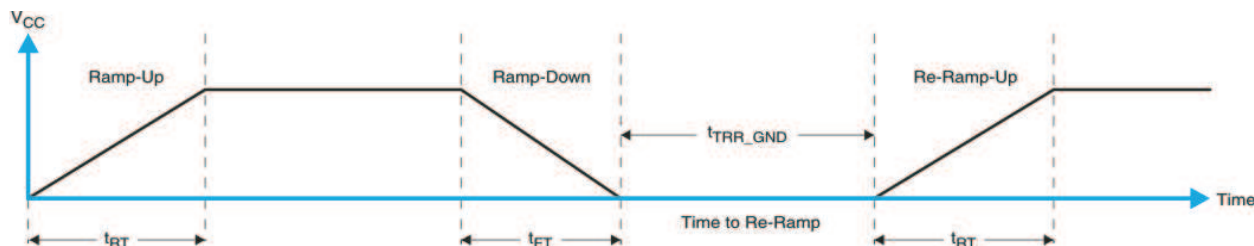

Figure 12.  $V_{CC}$  is Lowered Below 0.2 V or 0 V and Then Ramped Up to  $V_{CC}$

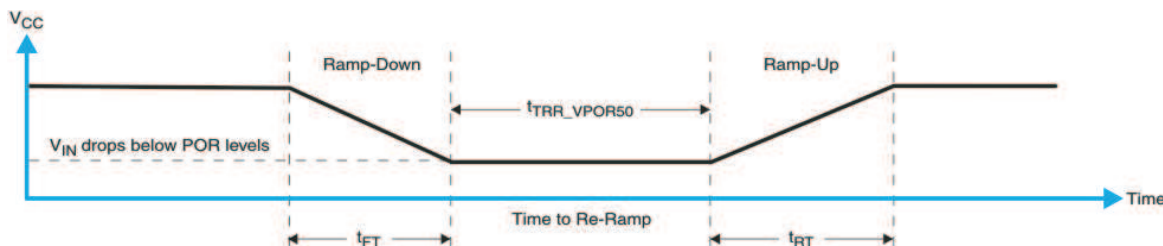

Figure 13.  $V_{CC}$  is Lowered Below the POR Threshold, Then Ramped Back Up to  $V_{CC}$

Glitches in the power supply can also affect the power-on reset performance of this device. The glitch width ( $t_{GW}$ ) and height ( $t_{GH}$ ) are dependent on each other. The bypass capacitance, source impedance, and device impedance are factors that affect power-on reset performance. Figure 14 provides more information on how to measure these specifications.



Figure 14. Glitch Width and Glitch Height

$V_{POR}$  is critical to the power-on reset.  $V_{POR}$  is the voltage level at which the reset condition is released and all the registers and the I2C/SMBus state machine are initialized to their default states. The value of  $V_{POR}$  differs based on the  $V_{CC}$  being lowered to or from 0. Figure 15 provides more details on this specification.

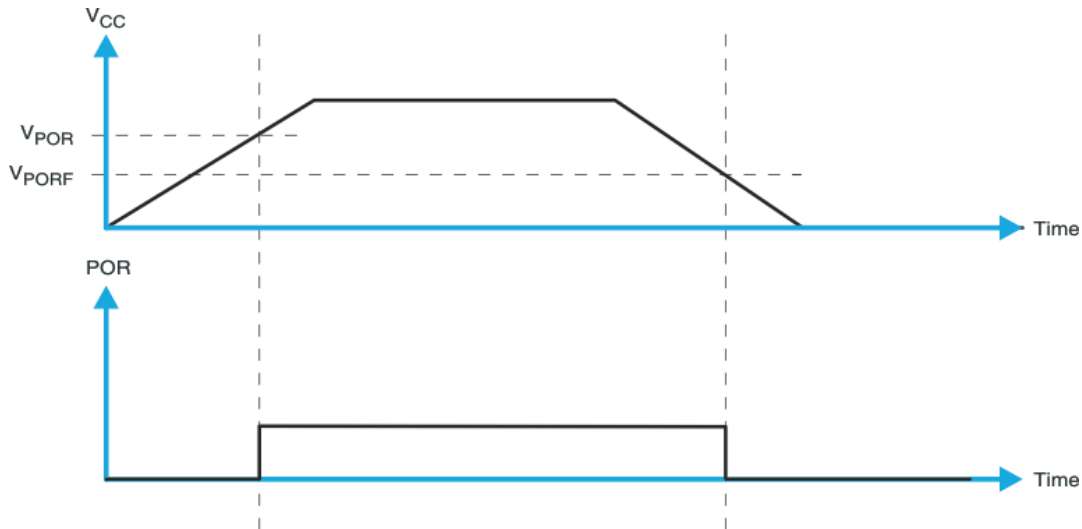
**Figure 15. VPOR**

The table below specifies the performance of the power-on reset feature for TCA7408 for both types of power-on reset.

**RECOMMENDED SUPPLY SEQUENCING AND RAMP RATES AT  $T_A = 25^\circ\text{C}$ <sup>(1)</sup>**

PARAMETER	DESCRIPTION	MIN	TYP	MAX	UNIT
$t_{FT}$	Fall rate	1		100	ms
$t_{RT}$	Rise rate	0.1		100	ms
$t_{RR\_GND}$	Time to re-ramp (when $V_{CC}$ drops to GND)	40			$\mu\text{s}$
$t_{RR\_POR50}$	Time to re-ramp (when $V_{CC}$ drops to $V_{POR\_MIN} - 50\text{ mV}$ )	40			$\mu\text{s}$
$V_{CC\_GH}$	Level that $V_{CCP}$ can glitch down to, but not cause a functional disruption when $V_{CCX\_GW} = 1\ \mu\text{s}$			1.2	V
$t_{GW}$	Glitch width that will not cause a functional disruption when $V_{CCX\_GH} = 0.5 \times V_{CCx}$			10	$\mu\text{s}$
$V_{PORF}$	Voltage trip point of POR on falling $V_{CC}$	0.86		1.22	V
$V_{PORR}$	Voltage trip point of POR on rising $V_{CC}$	1.1		1.34	V

(1) Not tested. Specified by design.

---

## REVISION HISTORY

Changes from Revision A (November 2012) to Revision B	Page
• Reverted document back to previous version. ....	1

---

**PACKAGING INFORMATION**

Orderable Device	Status (1)	Package Type	Package Drawing	Pins	Package Qty	Eco Plan (2)	Lead/Ball Finish (6)	MSL Peak Temp (3)	Op Temp (°C)	Device Marking (4/5)	Samples
TCA7408ZSZR	ACTIVE	uCSP	ZSZ	16	2500	Green (RoHS & no Sb/Br)	0.5NI   0.2AU	Level-2-260C-1 YEAR	-40 to 85	ZUQ	<b>Samples</b>

(1) The marketing status values are defined as follows:

**ACTIVE:** Product device recommended for new designs.

**LIFEBUY:** TI has announced that the device will be discontinued, and a lifetime-buy period is in effect.

**NRND:** Not recommended for new designs. Device is in production to support existing customers, but TI does not recommend using this part in a new design.

**PREVIEW:** Device has been announced but is not in production. Samples may or may not be available.

**OBSELETE:** TI has discontinued the production of the device.

(2) Eco Plan - The planned eco-friendly classification: Pb-Free (RoHS), Pb-Free (RoHS Exempt), or Green (RoHS & no Sb/Br) - please check <http://www.ti.com/productcontent> for the latest availability information and additional product content details.

**TBD:** The Pb-Free/Green conversion plan has not been defined.

**Pb-Free (RoHS):** TI's terms "Lead-Free" or "Pb-Free" mean semiconductor products that are compatible with the current RoHS requirements for all 6 substances, including the requirement that lead not exceed 0.1% by weight in homogeneous materials. Where designed to be soldered at high temperatures, TI Pb-Free products are suitable for use in specified lead-free processes.

**Pb-Free (RoHS Exempt):** This component has a RoHS exemption for either 1) lead-based flip-chip solder bumps used between the die and package, or 2) lead-based die adhesive used between the die and leadframe. The component is otherwise considered Pb-Free (RoHS compatible) as defined above.

**Green (RoHS & no Sb/Br):** TI defines "Green" to mean Pb-Free (RoHS compatible), and free of Bromine (Br) and Antimony (Sb) based flame retardants (Br or Sb do not exceed 0.1% by weight in homogeneous material)

(3) MSL, Peak Temp. - The Moisture Sensitivity Level rating according to the JEDEC industry standard classifications, and peak solder temperature.

(4) There may be additional marking, which relates to the logo, the lot trace code information, or the environmental category on the device.

(5) Multiple Device Markings will be inside parentheses. Only one Device Marking contained in parentheses and separated by a "-" will appear on a device. If a line is indented then it is a continuation of the previous line and the two combined represent the entire Device Marking for that device.

(6) Lead/Ball Finish - Orderable Devices may have multiple material finish options. Finish options are separated by a vertical ruled line. Lead/Ball Finish values may wrap to two lines if the finish value exceeds the maximum column width.

**Important Information and Disclaimer:**The information provided on this page represents TI's knowledge and belief as of the date that it is provided. TI bases its knowledge and belief on information provided by third parties, and makes no representation or warranty as to the accuracy of such information. Efforts are underway to better integrate information from third parties. TI has taken and continues to take reasonable steps to provide representative and accurate information but may not have conducted destructive testing or chemical analysis on incoming materials and chemicals. TI and TI suppliers consider certain information to be proprietary, and thus CAS numbers and other limited information may not be available for release.

In no event shall TI's liability arising out of such information exceed the total purchase price of the TI part(s) at issue in this document sold by TI to Customer on an annual basis.



## TAPE AND REEL INFORMATION



### QUADRANT ASSIGNMENTS FOR PIN 1 ORIENTATION IN TAPE



\*All dimensions are nominal

Device	Package Type	Package Drawing	Pins	SPQ	Reel Diameter (mm)	Reel Width W1 (mm)	A0 (mm)	B0 (mm)	K0 (mm)	P1 (mm)	W (mm)	Pin1 Quadrant
TCA7408ZSZR	uCSP	ZSZ	16	2500	330.0	8.4	2.18	2.18	0.7	4.0	8.0	Q1

TAPE AND REEL BOX DIMENSIONS



\*All dimensions are nominal

Device	Package Type	Package Drawing	Pins	SPQ	Length (mm)	Width (mm)	Height (mm)
TCA7408ZSZR	uCSP	ZSZ	16	2500	338.1	338.1	20.6

ZSZ (S-uCSP-N16)

MicrostarCSP™

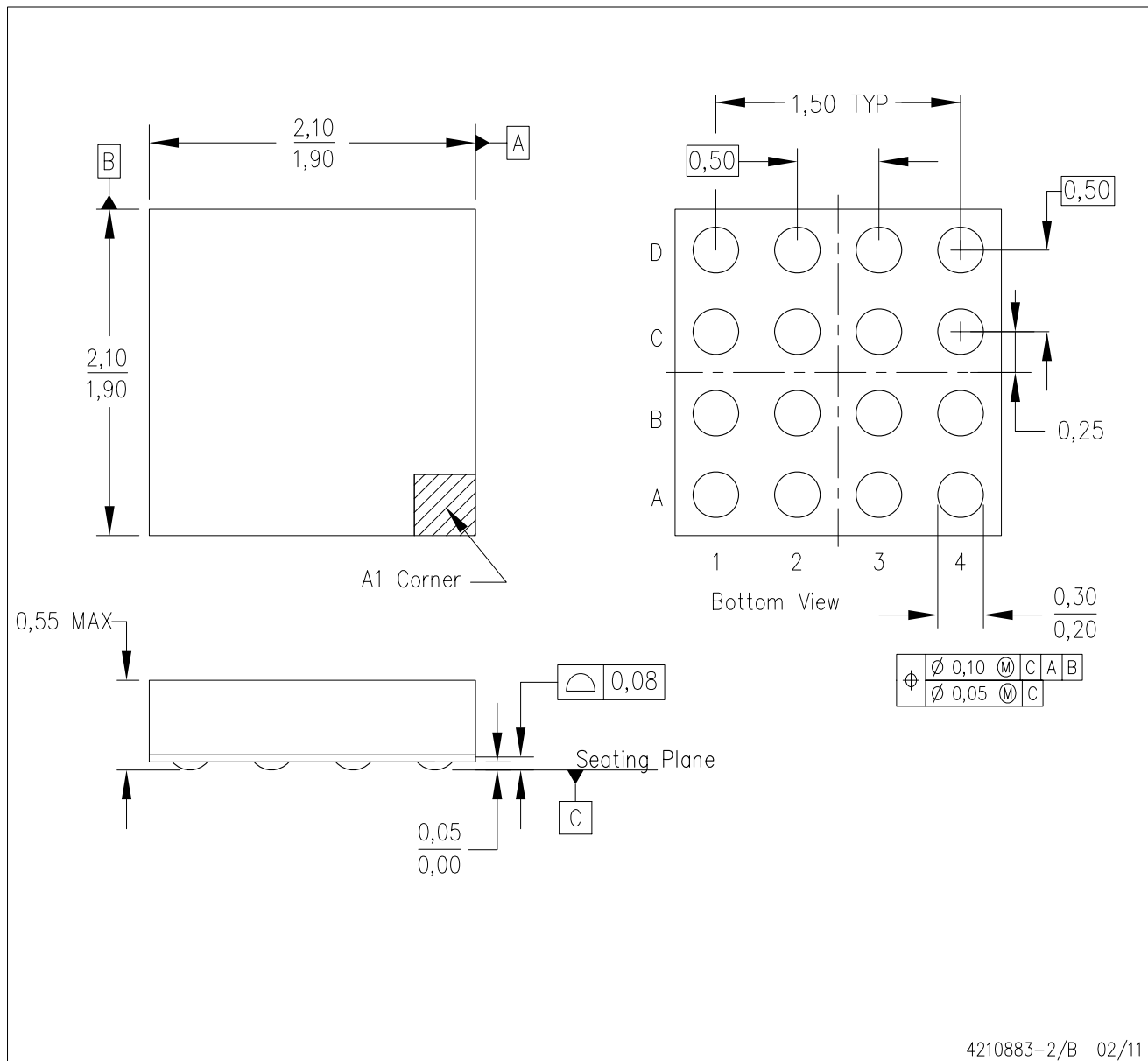

- NOTES:
- A. All linear dimensions are in millimeters. Dimensioning and tolerancing per ASME Y14.5M-1994.
  - B. This drawing is subject to change without notice.
  - C. MicrostarCSP™ configuration.
  - D. This is a PB-free solder ball design.

MicrostarCSP is a trademark of Texas Instruments.

## IMPORTANT NOTICE

Texas Instruments Incorporated and its subsidiaries (TI) reserve the right to make corrections, enhancements, improvements and other changes to its semiconductor products and services per JESD46, latest issue, and to discontinue any product or service per JESD48, latest issue. Buyers should obtain the latest relevant information before placing orders and should verify that such information is current and complete. All semiconductor products (also referred to herein as "components") are sold subject to TI's terms and conditions of sale supplied at the time of order acknowledgment.

TI warrants performance of its components to the specifications applicable at the time of sale, in accordance with the warranty in TI's terms and conditions of sale of semiconductor products. Testing and other quality control techniques are used to the extent TI deems necessary to support this warranty. Except where mandated by applicable law, testing of all parameters of each component is not necessarily performed.

TI assumes no liability for applications assistance or the design of Buyers' products. Buyers are responsible for their products and applications using TI components. To minimize the risks associated with Buyers' products and applications, Buyers should provide adequate design and operating safeguards.

TI does not warrant or represent that any license, either express or implied, is granted under any patent right, copyright, mask work right, or other intellectual property right relating to any combination, machine, or process in which TI components or services are used. Information published by TI regarding third-party products or services does not constitute a license to use such products or services or a warranty or endorsement thereof. Use of such information may require a license from a third party under the patents or other intellectual property of the third party, or a license from TI under the patents or other intellectual property of TI.

Reproduction of significant portions of TI information in TI data books or data sheets is permissible only if reproduction is without alteration and is accompanied by all associated warranties, conditions, limitations, and notices. TI is not responsible or liable for such altered documentation. Information of third parties may be subject to additional restrictions.

Resale of TI components or services with statements different from or beyond the parameters stated by TI for that component or service voids all express and any implied warranties for the associated TI component or service and is an unfair and deceptive business practice. TI is not responsible or liable for any such statements.

Buyer acknowledges and agrees that it is solely responsible for compliance with all legal, regulatory and safety-related requirements concerning its products, and any use of TI components in its applications, notwithstanding any applications-related information or support that may be provided by TI. Buyer represents and agrees that it has all the necessary expertise to create and implement safeguards which anticipate dangerous consequences of failures, monitor failures and their consequences, lessen the likelihood of failures that might cause harm and take appropriate remedial actions. Buyer will fully indemnify TI and its representatives against any damages arising out of the use of any TI components in safety-critical applications.

In some cases, TI components may be promoted specifically to facilitate safety-related applications. With such components, TI's goal is to help enable customers to design and create their own end-product solutions that meet applicable functional safety standards and requirements. Nonetheless, such components are subject to these terms.

No TI components are authorized for use in FDA Class III (or similar life-critical medical equipment) unless authorized officers of the parties have executed a special agreement specifically governing such use.

Only those TI components which TI has specifically designated as military grade or "enhanced plastic" are designed and intended for use in military/aerospace applications or environments. Buyer acknowledges and agrees that any military or aerospace use of TI components which have **not** been so designated is solely at the Buyer's risk, and that Buyer is solely responsible for compliance with all legal and regulatory requirements in connection with such use.

TI has specifically designated certain components as meeting ISO/TS16949 requirements, mainly for automotive use. In any case of use of non-designated products, TI will not be responsible for any failure to meet ISO/TS16949.

### Products

Audio	<a href="http://www.ti.com/audio">www.ti.com/audio</a>
Amplifiers	<a href="http://amplifier.ti.com">amplifier.ti.com</a>
Data Converters	<a href="http://dataconverter.ti.com">dataconverter.ti.com</a>
DLP® Products	<a href="http://www.dlp.com">www.dlp.com</a>
DSP	<a href="http://dsp.ti.com">dsp.ti.com</a>
Clocks and Timers	<a href="http://www.ti.com/clocks">www.ti.com/clocks</a>
Interface	<a href="http://interface.ti.com">interface.ti.com</a>
Logic	<a href="http://logic.ti.com">logic.ti.com</a>
Power Mgmt	<a href="http://power.ti.com">power.ti.com</a>
Microcontrollers	<a href="http://microcontroller.ti.com">microcontroller.ti.com</a>
RFID	<a href="http://www.ti-rfid.com">www.ti-rfid.com</a>
OMAP Applications Processors	<a href="http://www.ti.com/omap">www.ti.com/omap</a>
Wireless Connectivity	<a href="http://www.ti.com/wirelessconnectivity">www.ti.com/wirelessconnectivity</a>

### Applications

Automotive and Transportation	<a href="http://www.ti.com/automotive">www.ti.com/automotive</a>
Communications and Telecom	<a href="http://www.ti.com/communications">www.ti.com/communications</a>
Computers and Peripherals	<a href="http://www.ti.com/computers">www.ti.com/computers</a>
Consumer Electronics	<a href="http://www.ti.com/consumer-apps">www.ti.com/consumer-apps</a>
Energy and Lighting	<a href="http://www.ti.com/energy">www.ti.com/energy</a>
Industrial	<a href="http://www.ti.com/industrial">www.ti.com/industrial</a>
Medical	<a href="http://www.ti.com/medical">www.ti.com/medical</a>
Security	<a href="http://www.ti.com/security">www.ti.com/security</a>
Space, Avionics and Defense	<a href="http://www.ti.com/space-avionics-defense">www.ti.com/space-avionics-defense</a>
Video and Imaging	<a href="http://www.ti.com/video">www.ti.com/video</a>

### TI E2E Community

[e2e.ti.com](http://e2e.ti.com)