

32-Bit

Microcontroller

TC260 / 264 / 265 / 267

32-Bit Single-Chip Microcontroller
BC-Step

32-Bit Single-Chip Microcontroller

Data Sheet

V 1.0, 2017-06

Edition 2017-06

**Published by
Infineon Technologies AG
81726 Munich, Germany**

**© 2017 Infineon Technologies AG
All Rights Reserved.**

Legal Disclaimer

The information given in this document shall in no event be regarded as a guarantee of conditions or characteristics. With respect to any examples or hints given herein, any typical values stated herein and/or any information regarding the application of the device, Infineon Technologies hereby disclaims any and all warranties and liabilities of any kind, including without limitation, warranties of non-infringement of intellectual property rights of any third party.

Information

For further information on technology, delivery terms and conditions and prices, please contact the nearest Infineon Technologies Office (www.infineon.com)

Warnings

Due to technical requirements, components may contain dangerous substances. For information on the types in question, please contact the nearest Infineon Technologies Office.

Infineon Technologies components may be used in life-support devices or systems only with the express written approval of Infineon Technologies, if a failure of such components can reasonably be expected to cause the failure of that life-support device or system or to affect the safety or effectiveness of that device or system. Life support devices or systems are intended to be implanted in the human body or to support and/or maintain and sustain and/or protect human life. If they fail, it is reasonable to assume that the health of the user or other persons may be endangered.

Revision History

Page or Item	Subjects (major changes since previous revision)
V 1.0, 2017-06	
	The history is documented in the last chapter

Table of Contents

1	Summary of Features	1
2	Package and Pinning Definitions	5
2.1	TC264x Pin Definition and Functions: LQFP144	6
2.1.1	TC264 LQFP144 Package Variant Pin Configuration	7
2.1.2	Emergency Stop Function	50
2.1.3	Pull-Up/Pull-Down Reset Behavior of the Pins	51
2.2	TC265x Pin Definition and Functions: LQFP176	52
2.2.1	TC265 LQFP176 Package Variant Pin Configuration	53
2.2.2	Emergency Stop Function	105
2.2.3	Pull-Up/Pull-Down Reset Behavior of the Pins	106
2.3	TC267x Pin Definition and Functions: BGA292	107
2.3.1	TC267 BGA292 Package Variant Pin Configuration	108
2.3.2	Emergency Stop Function	162
2.3.3	Pull-Up/Pull-Down Reset Behavior of the Pins	162
2.4	TC260 Bare Die Pad Definition:	163
2.4.1	TC 260 / 264 / 265 / 267 Bare Die Pad Description	175
2.4.2	Pull-Up/Pull-Down Reset Behavior of the Pins	175
3	Electrical Specification	177
3.1	Parameter Interpretation	177
3.2	Absolute Maximum Ratings	178
3.3	Pin Reliability in Overload	179
3.4	Operating Conditions	182
3.5	5 V / 3.3 V switchable Pads	184
3.6	3.3 V only Pads	202
3.7	High performance LVDS Pads (LVDSH)	204
3.8	Medium performance LVDS Pads (LVDSM)	208
3.9	VADC Parameters	209
3.10	DSADC Parameters	215
3.11	MHz Oscillator	221
3.12	Back-up Clock	222
3.13	Temperature Sensor	223
3.14	Power Supply Current	224
3.14.1	Calculating the 1.3 V Current Consumption	228
3.15	Power-up and Power-down	229
3.15.1	External Supply Mode	229
3.15.2	Single Supply Mode	231
3.15.3	External Supply Mode	233
3.15.4	Single Supply Mode	235
3.16	Reset Timing	237
3.17	EVR	239
3.18	Phase Locked Loop (PLL)	245
3.19	ERAY Phase Locked Loop (ERAY_PLL)	246
3.20	AC Specifications	247
3.21	JTAG Parameters	248
3.22	DAP Parameters	250
3.23	ASCLIN SPI Master Timing	252
3.24	ASCLIN SPI Master Timing	255
3.25	QSPI Timings, Master and Slave Mode	259

3.26	QSPI Timings, Master and Slave Mode	265
3.27	MSC Timing 5 V Operation	271
3.28	MSC Timing 3.3 V Operation	276
3.29	Ethernet Interface (ETH) Characteristics	281
3.29.1	ETH Measurement Reference Points	281
3.29.2	ETH Management Signal Parameters (ETH_MDC, ETH_MDIO)	282
3.29.3	ETH MII Parameters	283
3.29.4	ETH RMII Parameters	284
3.30	E-Ray Parameters	285
3.31	HSCT Parameters	287
3.32	Inter-IC (I2C) Interface Timing	290
3.33	SCR Parameters	293
3.33.1	SSC Timing 5V	293
3.33.2	SPD Timing	295
3.33.3	WCAN Timing	295
3.34	CIF Parameters	297
3.35	Flash Target Parameters	303
3.36	Package Outline	306
3.36.1	Package Parameters	308
3.36.2	TC260 Carrier Tape	308
3.37	Quality Declarations	310
4	History	311

Trademarks of Infineon Technologies AG

AURIX™, C166™, CanPAK™, CIPOS™, CIPURSE™, EconoPACK™, CoolMOS™, CoolSET™, CORECONTROL™, CROSSAVE™, DAVE™, DI-POL™, EasyPIM™, EconoBRIDGE™, EconoDUAL™, EconoPIM™, EconoPACK™, EiceDRIVER™, eupec™, FCOS™, HITFET™, HybridPACK™, I²RF™, ISOFACE™, IsoPACK™, MIPAQ™, ModSTACK™, my-d™, NovalithIC™, OptiMOS™, ORIGA™, POWERCODE™; PRIMARION™, PrimePACK™, PrimeSTACK™, PRO-SIL™, PROFET™, RASIC™, ReverSave™, SatRIC™, SIEGET™, SINDRION™, SIPMOS™, SmartLEWIS™, SOLID FLASH™, TEMPFET™, thinQ!™, TRENCHSTOP™, TriCore™.

Other Trademarks

Advance Design System™ (ADS) of Agilent Technologies, AMBA™, ARM™, MULTI-ICE™, KEIL™, PRIMECELL™, REALVIEW™, THUMB™, μ Vision™ of ARM Limited, UK. AUTOSAR™ is licensed by AUTOSAR development partnership. Bluetooth™ of Bluetooth SIG Inc. CAT-iq™ of DECT Forum. COLOSSUS™, FirstGPS™ of Trimble Navigation Ltd. EMV™ of EMVCo, LLC (Visa Holdings Inc.). EPCOS™ of Epcos AG. FLEXGO™ of Microsoft Corporation. FlexRay™ is licensed by FlexRay Consortium. HYPERTERMINAL™ of Hilgraeve Incorporated. IEC™ of Commission Electrotechnique Internationale. IrDA™ of Infrared Data Association Corporation. ISO™ of INTERNATIONAL ORGANIZATION FOR STANDARDIZATION. MATLAB™ of MathWorks, Inc. MAXIM™ of Maxim Integrated Products, Inc. MICROTEC™, NUCLEUS™ of Mentor Graphics Corporation. MIPI™ of MIPI Alliance, Inc. MIPS™ of MIPS Technologies, Inc., USA. muRata™ of MURATA MANUFACTURING CO., MICROWAVE OFFICE™ (MWO) of Applied Wave Research Inc., OmniVision™ of OmniVision Technologies, Inc. Openwave™ Openwave Systems Inc. RED HAT™ Red Hat, Inc. RFMD™ RF Micro Devices, Inc. SIRIUS™ of Sirius Satellite Radio Inc. SOLARIS™ of Sun Microsystems, Inc. SPANSION™ of Spansion LLC Ltd. Symbian™ of Symbian Software Limited. TAIYO YUDEN™ of Taiyo Yuden Co. TEAKLITE™ of CEVA, Inc. TEKTRONIX™ of Tektronix Inc. TOKO™ of TOKO KABUSHIKI KAISHA TA. UNIX™ of X/Open Company Limited. VERILOG™, PALLADIUM™ of Cadence Design Systems, Inc. VLYNQ™ of Texas Instruments Incorporated. VXWORKS™, WIND RIVER™ of WIND RIVER SYSTEMS, INC. ZETEX™ of Diodes Zetex Limited.

Last Trademarks Update 2011-11-11

1 Summary of Features

The **TC26x** product family has the following features:

- High Performance Microcontroller with two CPU cores
- One 32-bit super-scalar TriCore CPUs (TC1.6P), having the following features:
 - Superior real-time performance
 - Strong bit handling
 - Fully integrated DSP capabilities
 - Multiply-accumulate unit able to sustain 2 MAC operations per cycle
 - up to 200 MHz operation at full temperature range
 - up to 120 Kbyte Data Scratch-Pad RAM (DSPR)
 - up to 32 Kbyte Instruction Scratch-Pad RAM (PSPR)
 - 16 Kbyte Instruction Cache (ICACHE)
 - 8 Kbyte Data Cache (DCACHE)
- Power Efficient scalar TriCore CPU (TC1.6E), having the following features:
 - Binary code compatibility with TC1.6P
 - up to 200 MHz operation at full temperature range
 - up to 72 Kbyte Data Scratch-Pad RAM (DSPR)
 - up to 16 Kbyte Instruction Scratch-Pad RAM (PSPR)
 - 8 Kbyte Instruction Cache (ICACHE)
 - 0.125Kbyte Data Read Buffer (DRB)
- Lockstepped shadow core for TC1.6P
- Multiple on-chip memories
 - All embedded NVM and SRAM are ECC protected
 - up to 2.5 Mbyte Program Flash Memory (PFLASH)
 - up to 96 Kbyte Data Flash Memory (DFLASH) usable for EEPROM emulation
 - 0 Kbyte Memory (LMU)
 - BootROM (BROM)
- 48-Channel DMA Controller with safe data transfer
- Sophisticated interrupt system (ECC protected)
- High performance on-chip bus structure
 - 64-bit Cross Bar Interconnect (SRI) giving fast parallel access between busmasters, CPUs and memories
 - 32-bit System Peripheral Bus (SPB) for on-chip peripheral and functional units
 - One bus bridge (SFI Bridge)
- Safety Management Unit (SMU) handling safety monitor alarms
- Memory Test Unit with ECC, Memory Initialization and MBIST functions (MTU)
- Hardware I/O Monitor (IOM) for checking of digital I/O
- Versatile On-chip Peripheral Units
 - Four Asynchronous/Synchronous Serial Channels (ASCLIN) with hardware LIN support (V1.3, V2.0, V2.1 and J2602) up to 50 MBaud
 - Four Queued SPI Interface Channels (QSPI) with master and slave capability upto 50 Mbit/s
 - High Speed Serial Link (HSSL) for serial inter-processor communication up to 320Mbit/s

Summary of Features

- Two serial Micro Second Bus interfaces (MSC) for serial port expansion to external power devices
- One MultiCAN+ Module with 5 CAN nodes and 256 free assignable messageobjects for high efficiency data handling via FIFO buffering and gateway data transfer
- 6 Single Edge Nibble Transmission (SENT) channels for connection to sensors
- One FlexRay™ module with 2 channels (E-Ray) supporting V2.1
- One Generic Timer Module (GTM) providing a powerful set of digital signal filtering and timer functionality to realize autonomous and complex Input/Output management
- One Capture / Compare 6 module (Two kernels CCU60 and CCU61)
- One General Purpose 12 Timer Unit (GPT120)
- Three channel Peripheral Sensor Interface conforming to V1.3 (PSI5)
- Peripheral Sensor Interface with Serial PHY (PSI5-S)
- Inter-Integrated Circuit Bus Interface (I2C) conforming to V2.1
- IEEE802.3 Ethernet MAC with RMII and MII interfaces (ETH)
- 8-bit Standby Controller (TC2x_SCR)
 - Two 8-bit timers
 - One 16-bit timer
 - Timer 2 Capture Compare Unit
 - Real Time Clock
 - Universal Asynchronous Receiver/Transmitter
 - High Speed Synchronous Serial Interface
 - Wake-up CAN Filter
- Versatile Successive Approximation ADC (VADC)
 - Cluster of 4 independent ADC kernels
 - Input voltage range from 0 V to 5.5V (ADC supply)
- Delta-Sigma ADC (DSADC)
 - Three/Four channels
- Digital programmable I/O ports
- On-chip debug support for OCDS Level 1 (CPUs , DMA, On Chip Buses)
- Dedicated Emulation Device chip available (ED)
 - multi-core debugging, real time tracing, and calibration
 - Aurora Gigabit Trace Port (AGBT) on some variants (See below)
 - four/five wire JTAG (IEEE 1149.1) or DAP (Device Access Port) interface
- Power Management System and on-chip regulators
- Clock Generation Unit with System PLL and Flexray PLL
- Embedded Voltage Regulator

The support of the Feature 8-bit Standby Controller (TC2x_SCR) is discontinued.

Ordering Information

The ordering code for Infineon microcontrollers provides an exact reference to the required product. This ordering code identifies:

- The derivative itself, i.e. its function set, the temperature range, and the supply voltage
- The package and the type of delivery.

For the available ordering codes for the TC 260 / 264 / 265 / 267 please refer to the “**AURIX™ TC2x Data Sheet Addendum**”, which summarizes all available variants.

Table 1-1 Overview of TC 260 / 264 / 265 / 267 Functions

Feature		
CPU Core	Type	TC1.6P / TC1.6E
	P Cores / Checker Cores / E Cores / Checker Cores	1 / 1 / 1 / 0
	Max. Freq.	200 MHz
	FPU	yes
	Program Flash	Size
Data Flash	Size	96 Kbyte
Cache	Instruction	16 Kbyte / 8 Kbyte
	Data	8 Kbyte / -
SRAM	Size TC1.6P (DPSR/PSPR)	120 Kbyte / 32 Kbyte ²⁾
	Size TC1.6E (DPSR/PSPR)	72 Kbyte / 16 Kbyte ^{1) 2)}
	Size LMU	0 Kbyte
DMA	Channels	48
ADC	Channels	38 + 12
	Converter	4
DSADC	Channels	3 / 4
GTM	TIM	3
	TOM	2
	ATOM / MCS	4 / 3
	CMU / ICM	1 / 1
	PSM	1
	TBU	1
	SPE	2
	CMP / MON	1 / 1
	BRC / DPLL	0 / 1
Timer	GPT12	2
	CCU6	2

Summary of Features

Table 1-1 Overview of TC 260 / 264 / 265 / 267 Functions

Feature		
STM	Modules	2
FlexRay	Modules	1
	Channels	2
CAN	Nodes	5
	Message Objects	256
QSPI	Channels	4
ASCLIN	Interfaces	4
I2C	Interfaces	1
SENT	Modules	6
PSI5	Channels	3
PSI5-S	Modules	1
HSSL	Channels	1
MSC	Channels	2
Ethernet	Channels	1
ASIL	Level	up to ASIL-D
FCE	Modules	1
Safety Support	SMU	1
	IOM	1
ADAS		No
Standby-Controller Feature Discontinued	8-bit	Yes
Embedded Voltage Regulator	DCDC from 5 V / 3.3 V to 1.3 V	Yes
	LDO from 5 V / 3.3 V to 1.3 V	Yes
	LDO from 5 V to 3.3 V	Yes
Low Power Features	Standby RAM	Yes
Packages	Type	PG-LQFP-144-22 / PG-LQFP-176-22 / PG-LFBGA-292-6
I/O	Type	5 V CMOS / 3.3 V CMOS / LVDS
T _{ambient}	Range	-40 ... + 150°C

1) Address range starts at lowest address defined in the User's Manual. For reference see the Memory Maps chapter of the User's Manual.

- 2) To ensure the processor cores are provided with a constant stream of instructions the Instruction Fetch Units will speculatively fetch instructions from the up to 64 bytes ahead of the current PC.
If the current PC is within 64 bytes of the top of an instruction memory the Instruction Fetch Unit may attempt to speculatively fetch instruction from beyond the physical range. This may then lead to error conditions and alarms being triggered by the bus and memory systems.
It is therefore recommended that the upper 64 bytes of any memory be unused for instruction storage.

2 Package and Pinning Definitions

This chapter gives a pinning of the different packages of the TC 260 / 264 / 265 / 267.

2.1 TC264x Pin Definition and Functions: LQFP144

Figure 2-1 is showing the TC264x Logic Symbol for the package variant: QFP144.

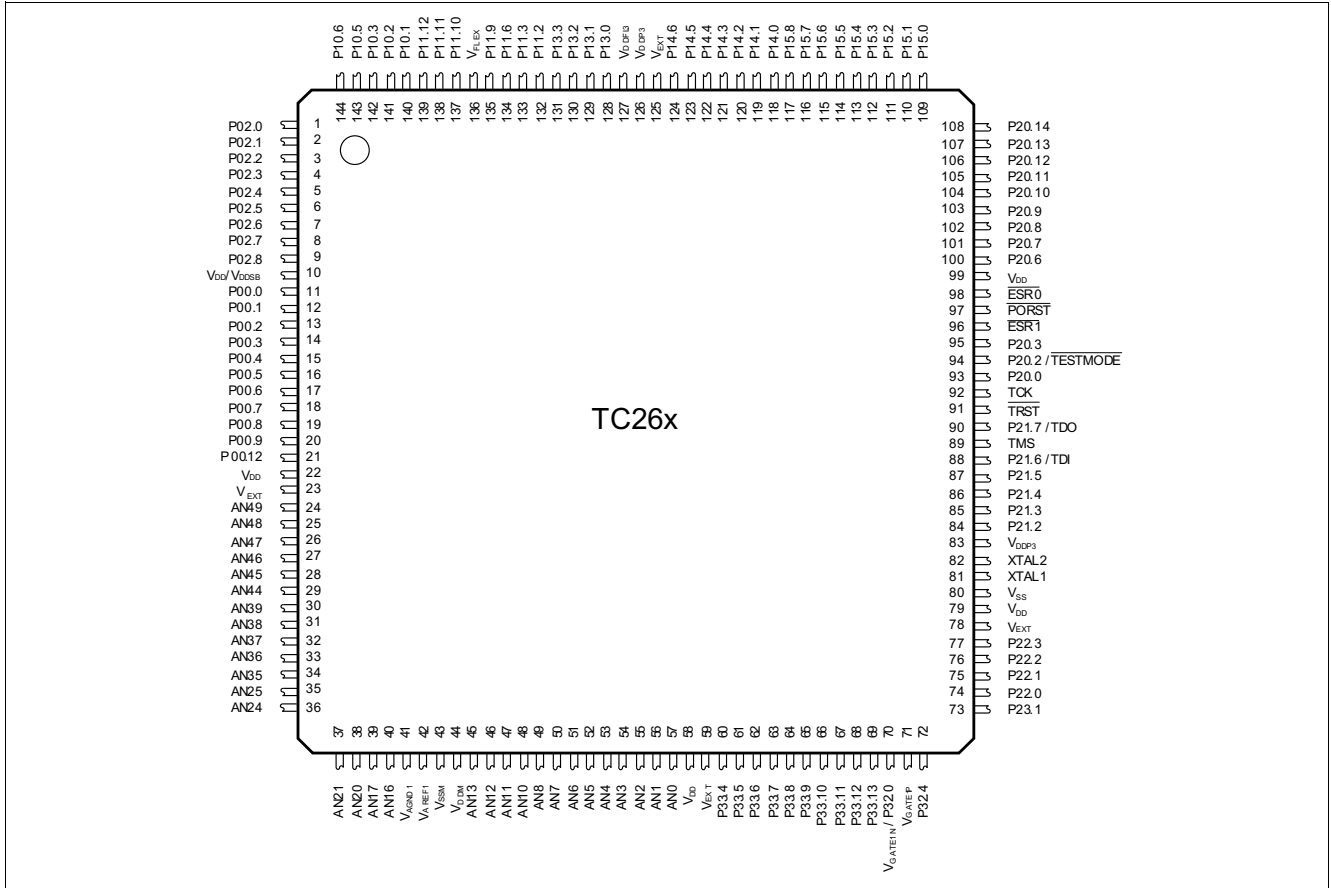

Figure 2-1 TC264x Logic Symbol for the package variant LQFP144.

2.1.1 TC264 LQFP144 Package Variant Pin Configuration

Table 2-1 Port 00 Functions

Pin	Symbol	Ctrl	Type	Function
11	P00.0	I	MP / PU1 / VEXT	General-purpose input
	TIN9			GTM input
	CTRAPA			CCU61 input
	T12HRE			CCU60 input
	INJ00			MSC0 input
	CIFD9			CIF input
	P00.0	O0		General-purpose output
	TOUT9	O1		GTM output
	ASCLK3	O2		ASCLIN3 output
	ATX3	O3		ASCLIN3 output
	–	O4		Reserved
	TXDCAN1	O5		CAN node 1 output
	–	O6		Reserved
	COU63	O7		CCU60 output
ETHMDIOA	I/O	ETH input/output		
12	P00.1	I	LP / PU1 / VEXT	General-purpose input
	TIN10			GTM input
	ARX3E			ASCLIN3 input
	RXDCAN1D			CAN node 1 input
	PSIRX0A			PSI5 input
	SENT0B			SENT input
	CC60INB			CCU60 input
	CC60INA			CCU61 input
	DSCIN0A			DSADC channel 0 input A
	VADCG3.11			VADC analog input channel 11 of group 3
	CIFD10			CIF input
	P00.1	O0		General-purpose output
	TOUT10	O1		GTM output
	ATX3	O2		ASCLIN3 output
	–	O3		Reserved
	DSCOUT0	O4		DSADC channel 0 output
	–	O5		Reserved
	SPC0	O6		SENT output
CC60	O7	CCU61 output		

Package and Pinning Definitions TC264x Pin Definition and Functions:

Table 2-1 Port 00 Functions (cont'd)

Pin	Symbol	Ctrl	Type	Function
13	P00.2	I	LP / PU1 / VEXT	General-purpose input
	TIN11			GTM input
	SENT1B			SENT input
	DSDIN0A			DSADC channel 0 input A
	VADCG3.10			VADC analog input channel 10 of group 3 (MD)
	CIFD11			CIF input
	P00.2			O0
	TOUT11	O1		GTM output
	ASCLK3	O2		ASCLIN3 output
	–	O3		Reserved
	PSITX0	O4		PSI5 output
	TXDCAN3	O5		CAN node 3 output
	–	O6		Reserved
	COOUT60	O7		CCU61 output
14	P00.3	I	LP / PU1 / VEXT	General-purpose input
	TIN12			GTM input
	RXDCAN3A			CAN node 3 input
	PSIRX1A			PSI5 input
	PSISRXA			PSI5-S input
	SENT2B			SENT input
	CC61INB			CCU60 input
	CC61INA			CCU61 input
	DSCIN3A			DSADC channel 3 input A
	VADCG3.9			VADC analog input channel 9 of group 3 (MD)
	CIFD12			CIF input
	P00.3			O0
	TOUT12	O1		GTM output
	ASLSO3	O2		ASCLIN3 output
	–	O3		Reserved
	DSCOUT3	O4		DSADC channel 3 output
	–	O5		Reserved
	SPC2	O6		SENT output
CC61	O7	CCU61 output		

Package and Pinning Definitions TC264x Pin Definition and Functions:

Table 2-1 Port 00 Functions (cont'd)

Pin	Symbol	Ctrl	Type	Function
15	P00.4	I	LP / PU1 / VEXT	General-purpose input
	TIN13			GTM input
	REQ7			SCU input
	SENT3B			SENT input
	DSDIN3A			DSADC channel 3 input A
	DSSGNA			DSADC input
	VADCG3.8			VADC analog input channel 8 of group 3
	CIFD13			CIF input
	P00.4			O0
	TOUT13	O1		GTM output
	PSISTX	O2		PSI5-S output
	TXDCAN4	O3		CAN node 4 output
	PSITX1	O4		PSI5 output
	VADCG2BFL0	O5		VADC output
	SPC3	O6		SENT output
	COU61	O7		CCU61 output
	16	P00.5		I
TIN14		GTM input		
PSIRX2A		PSI5 input		
SENT4B		SENT input		
RXDCAN4A		CAN node 4 input		
CC62INB		CCU60 input		
CC62INA		CCU61 input		
DSCIN2A		DSADC channel 2 input A		
VADCG3.7		VADC analog input channel 7 of group 3		
CIFD14		CIF input		
P00.5		O0	General-purpose output	
TOUT14		O1	GTM output	
DSCGPWMN		O2	DSADC output	
–		O3	Reserved	
DSCOUT2		O4	DSADC channel 2 output	
VADCG2BFL1		O5	VADC output	
SPC4		O6	SENT output	
CC62	O7	CCU61 output		

Package and Pinning Definitions TC264x Pin Definition and Functions:

Table 2-1 Port 00 Functions (cont'd)

Pin	Symbol	Ctrl	Type	Function
17	P00.6	I	LP / PU1 / VEXT	General-purpose input
	TIN15			GTM input
	SENT5B			SENT input
	DSDIN2A			DSADC channel 2 input A
	VADCG3.6			VADC analog input channel 6 of group 3
	CIFD15			CIF input
	P00.6			O0
	TOUT15	O1		GTM output
	DSCGPWMP	O2		DSADC output
	VADCG2BFL2	O3		VADC output
	PSITX2	O4		PSI5 output
	VADCEMUX10	O5		VADC output
	SPC5	O6		SENT output
	COU62	O7		CCU61 output
18	P00.7	I	LP / PU1 / VEXT	General-purpose input
	TIN16			GTM input
	CC60INC			CCU61 input
	CCPOS0A			CCU61 input
	T12HRB			CCU60 input
	T2INA			GPT120 input
	VADCG3.5			VADC analog input channel 5 of group 3
	CIFCLK			CIF input
	P00.7	O0		General-purpose output
	TOUT16	O1		GTM output
	–	O2		Reserved
	VADCG2BFL3	O3		VADC output
	–	O4		Reserved
	VADCEMUX11	O5		VADC output
	–	O6		Reserved
	CC60	O7		CCU61 output

Package and Pinning Definitions TC264x Pin Definition and Functions:

Table 2-1 Port 00 Functions (cont'd)

Pin	Symbol	Ctrl	Type	Function
19	P00.8	I	LP / PU1 / VEXT	General-purpose input
	TIN17			GTM input
	CC61INC			CCU61 input
	CCPOS1A			CCU61 input
	T13HRB			CCU60 input
	T2EUDA			GPT120 input
	VADCG3.4			VADC analog input channel 4 of group 3
	CIFVSNC			CIF input
	P00.8	O0		General-purpose output
	TOUT17	O1		GTM output
	SLSO36	O2		QSPI3 output
	–	O3		Reserved
	–	O4		Reserved
	VADCEMUX12	O5		VADC output
	–	O6		Reserved
	CC61	O7		CCU61 output
20	P00.9	I	LP / PU1 / VEXT	General-purpose input
	TIN18			GTM input
	CC62INC			CCU61 input
	CCPOS2A			CCU61 input
	T13HRC			CCU60 input
	T12HRC			CCU60 input
	T4EUDA			GPT120 input
	VADCG3.3			VADC analog input channel 3 of group 3
	DSITR3F			DSADC channel 3 input F
	CIFHSNC			CIF input
	P00.9	O0		General-purpose output
	TOUT18	O1		GTM output
	SLSO37	O2		QSPI3 output
	ARTS3	O3		ASCLIN3 output
	–	O4		Reserved
	–	O5		Reserved
–	O6	Reserved		
CC62	O7	CCU61 output		

Package and Pinning Definitions TC264x Pin Definition and Functions:

Table 2-1 Port 00 Functions (cont'd)

Pin	Symbol	Ctrl	Type	Function
21	P00.12	I	LP / PU1 / VEXT	General-purpose input
	TIN21			GTM input
	ACTS3A			ASCLIN3 input
	VADCG3.0			VADC analog input channel 0 of group 3
	P00.12	O0		General-purpose output
	TOUT21	O1		GTM output
	–	O2		Reserved
	–	O3		Reserved
	–	O4		Reserved
	–	O5		Reserved
	–	O6		Reserved
	COUT63	O7		CCU61 output

Table 2-2 Port 02 Functions

Pin	Symbol	Ctrl	Type	Function
1	P02.0	I	MP+ / PU1 / VEXT	General-purpose input
	TIN0			GTM input
	ARX2G			ASCLIN2 input
	REQ6			SCU input
	CC60INA			CCU60 input
	CC60INB			CCU61 input
	CIFD0			CIF input
	P02.0			O0
	TOUT0	O1		GTM output
	ATX2	O2		ASCLIN2 output
	SLSO31	O3		QSPI3 output
	DSCGPWMN	O4		DSADC output
	TXDCAN0	O5		CAN node 0 output
	TXDA	O6		ERAY output
	CC60	O7		CCU60 output

Package and Pinning Definitions TC264x Pin Definition and Functions:

Table 2-2 Port 02 Functions (cont'd)

Pin	Symbol	Ctrl	Type	Function
2	P02.1	I	LP / PU1 / VEXT	General-purpose input
	TIN1			GTM input
	REQ14			SCU input
	ARX2B			ASCLIN2 input
	RXDCAN0A			CAN node 0 input
	RXDA2			ERAY input
	CIFD1			CIF input
	P02.1	O0		General-purpose output
	TOUT1	O1		GTM output
	–	O2		Reserved
	SLSO32	O3		QSPI3 output
	DSCGPWMP	O4		DSADC output
	–	O5		Reserved
	–	O6		Reserved
COU60	O7	CCU60 output		
3	P02.2	I	MP+ / PU1 / VEXT	General-purpose input
	TIN2			GTM input
	CC61INA			CCU60 input
	CC61INB			CCU61 input
	CIFD2			CIF input
	P02.2	O0		General-purpose output
	TOUT2	O1		GTM output
	ATX1	O2		ASCLIN1 output
	SLSO33	O3		QSPI3 output
	PSITX0	O4		PSI5 output
	TXDCAN2	O5		CAN node 2 output
	TXDB	O6		ERAY output
	CC61	O7		CCU60 output

Package and Pinning Definitions TC264x Pin Definition and Functions:

Table 2-2 Port 02 Functions (cont'd)

Pin	Symbol	Ctrl	Type	Function
4	P02.3	I	LP / PU1 / VEXT	General-purpose input
	TIN3			GTM input
	ARX1G			ASCLIN1 input
	RXDCAN2B			CAN node 2 input
	RXDB2			ERAY input
	PSIRX0B			PSI5 input
	SDI11			MSC1 input
	CIFD3			CIF input
	P02.3			O0
	TOUT3	O1		GTM output
	ASLSO2	O2		ASCLIN2 output
	SLSO34	O3		QSPI3 output
	–	O4		Reserved
	–	O5		Reserved
	–	O6		Reserved
	COUT61	O7		CCU60 output
5	P02.4	I	MP+ / PU1 / VEXT	General-purpose input
	TIN4			GTM input
	SLSI3A			QSPI3 input
	ECTT1			TTCAN input
	RXDCAN0D			CAN node 0 input
	CC62INA			CCU60 input
	CC62INB			CCU61 input
	SDA0A			I2C0 input
	CIFD4			CIF input
	P02.4	O0		General-purpose output
	TOUT4	O1		GTM output
	ASCLK2	O2		ASCLIN2 output
	SLSO30	O3		QSPI3 output
	PSISCLK	O4		PSI5-S output
	SDA0	O5		I2C0 output
	TXENA	O6		ERAY output
CC62	O7	CCU60 output		

Package and Pinning Definitions TC264x Pin Definition and Functions:

Table 2-2 Port 02 Functions (cont'd)

Pin	Symbol	Ctrl	Type	Function
6	P02.5	I	MP+ / PU1 / VEXT	General-purpose input
	TIN5			GTM input
	MRST3A			QSPI3 input
	ECTT2			TTCAN input
	PSIRX1B			PSI5 input
	PSISRXB			PSI5-S input
	SENT3C			SENT input
	SCL0A			I2C0 input
	CIFD5			CIF input
	P02.5			O0
	TOUT5	O1		GTM output
	TXDCAN0	O2		CAN node 0 output
	MRST3	O3		QSPI3 output
	–	O4		Reserved
	SCL0	O5		I2C0 output
	TXENB	O6		ERAY output
	COU62	O7		CCU60 output
	7	P02.6		I
TIN6		GTM input		
MTR3A		QSPI3 input		
SENT2C		SENT input		
CC60INC		CCU60 input		
CCPOS0A		CCU60 input		
T12HRB		CCU61 input		
T3INA		GPT120 input		
CIFD6		CIF input		
P02.6		O0	General-purpose output	
TOUT6		O1	GTM output	
PSISTX		O2	PSI5-S output	
MTR3		O3	QSPI3 output	
PSITX1		O4	PSI5 output	
VADCEMUX00		O5	VADC output	
–		O6	Reserved	
CC60		O7	CCU60 output	

Package and Pinning Definitions TC264x Pin Definition and Functions:

Table 2-2 Port 02 Functions (cont'd)

Pin	Symbol	Ctrl	Type	Function
8	P02.7	I	MP / PU1 / VEXT	General-purpose input
	TIN7			GTM input
	SCLK3A			QSPI3 input
	PSIRX2B			PSI5 input
	SENT1C			SENT input
	CC61INC			CCU60 input
	CCPOS1A			CCU60 input
	T13HRB			CCU61 input
	T3EUDA			GPT120 input
	CIFD7			CIF input
	DSCIN3B			DSADC channel 3 input B
	P02.7			O0
	TOUT7	O1	GTM output	
	–	O2	Reserved	
	SCLK3	O3	QSPI3 output	
	DSCOUT3	O4	DSADC channel 3 output	
	VADCEMUX01	O5	VADC output	
	SPC1	O6	SENT output	
	CC61	O7	CCU60 output	
9	P02.8	I	LP / PU1 / VEXT	General-purpose input
	TIN8			GTM input
	SENT0C			SENT input
	CC62INC			CCU60 input
	CCPOS2A			CCU60 input
	T12HRC			CCU61 input
	T13HRC			CCU61 input
	T4INA			GPT120 input
	CIFD8			CIF input
	DSDIN3B			DSADC channel 3 input B
	DSITR3E			DSADC channel 3 input E
	P02.8			O0
	TOUT8	O1	GTM output	
	SLSO35	O2	QSPI3 output	
	–	O3	Reserved	
	PSITX2	O4	PSI5 output	
	VADCEMUX02	O5	VADC output	
	ETHMDC	O6	ETH output	
	CC62	O7	CCU60 output	

Package and Pinning Definitions TC264x Pin Definition and Functions:

Table 2-3 Port 10 Functions

Pin	Symbol	Ctrl	Type	Function
140	P10.1	I	MP+ / PU1 / VEXT	General-purpose input
	TIN103			GTM input
	MRST1A			QSPI1 input
	T5EUDB			GPT120 input
	P10.1	O0		General-purpose output
	TOUT103	O1		GTM output
	MTSR1	O2		QSPI1 output
	MRST1	O3		QSPI1 output
	EN01	O4		MSC0 output
	VADCG3BFL1	O5		VADC output
	END03	O6		MSC0 output
	–	O7		Reserved
	141	P10.2		I
TIN104		GTM input		
SCLK1A		QSPI1 input		
T6INB		GPT120 input		
REQ2		SCU input		
RXDCAN2E		CAN node 2 input		
SDI01		MSC0 input		
P10.2		O0	General-purpose output	
TOUT104		O1	GTM output	
–		O2	Reserved	
SCLK1		O3	QSPI1 output	
EN00		O4	MSC0 output	
VADCG3BFL2		O5	VADC output	
END02		O6	MSC0 output	
–		O7	Reserved	

Package and Pinning Definitions TC264x Pin Definition and Functions:

Table 2-3 Port 10 Functions (cont'd)

Pin	Symbol	Ctrl	Type	Function
142	P10.3	I	MP / PU1 / VEXT	General-purpose input
	TIN105			GTM input
	MTSR1A			QSPI1 input
	REQ3			SCU input
	T5INB			GPT120 input
	P10.3	O0		General-purpose output
	TOUT105	O1		GTM output
	VADCG3BFL3	O2		VADC output
	MTSR1	O3		QSPI1 output
	EN00	O4		MSC0 output
	END02	O5		MSC0 output
	TXDCAN2	O6		CAN node 2 output
	–	O7		Reserved
	143	P10.5		I
TIN107		GTM input		
HWCFG4		SCU input		
RXDCAN4B		CAN node 4 input		
INJ01		MSC0 input		
P10.5		O0	General-purpose output	
TOUT107		O1	GTM output	
ATX2		O2	ASCLIN2 output	
SLSO38		O3	QSPI3 output	
SLSO19		O4	QSPI1 output	
T6OUT		O5	GPT120 output	
ASLSO2		O6	ASCLIN2 output	
–		O7	Reserved	

Package and Pinning Definitions TC264x Pin Definition and Functions:

Table 2-3 Port 10 Functions (cont'd)

Pin	Symbol	Ctrl	Type	Function
144	P10.6	I	LP / PU1 / VEXT	General-purpose input
	TIN108			GTM input
	ARX2D			ASCLIN2 input
	MTSR3B			QSPI3 input
	HWCFG5			SCU input
	P10.6	O0		General-purpose output
	TOUT108	O1		GTM output
	ASCLK2	O2		ASCLIN2 output
	MTSR3	O3		QSPI3 output
	T3OUT	O4		GPT120 output
	TXDCAN4	O5		CAN node 4 output
	MRST1	O6		QSPI1 output
	VADCG3BFL0	O7		VADC output

Table 2-4 Port 11 Functions

Pin	Symbol	Ctrl	Type	Function
132	P11.2	I	MPR / PU1 / VFLEX	General-purpose input
	TIN95			GTM input
	P11.2	O0		General-purpose output
	TOUT95	O1		GTM output
	END03	O2		MSC0 output
	SLSO05	O3		QSPI0 output
	SLSO15	O4		QSPI1 output
	EN01	O5		MSC0 output
	ETHTXD1	O6		ETH output
	COUT63	O7		CCU60 output
133	P11.3	I	MPR / PU1 / VFLEX	General-purpose input
	TIN96			GTM input
	MRST1B			QSPI1 input
	SDI03			MSC0 input
	P11.3	O0		General-purpose output
	TOUT96	O1		GTM output
	–	O2		Reserved
	MRST1	O3		QSPI1 output
	TXDA	O4		ERAY output
	–	O5		Reserved
	ETHTXD0	O6		ETH output
	COUT62	O7		CCU60 output

Package and Pinning Definitions TC264x Pin Definition and Functions:

Table 2-4 Port 11 Functions (cont'd)

Pin	Symbol	Ctrl	Type	Function
134	P11.6	I	MPR / PU1 / VFLEX	General-purpose input
	TIN97			GTM input
	SCLK1B			QSPI1 input
	P11.6	O0		General-purpose output
	TOUT97	O1		GTM output
	TXENB	O2		ERAY output
	SCLK1	O3		QSPI1 output
	TXENA	O4		ERAY output
	FCLP0	O5		MSC0 output
	ETHTXEN	O6		ETH output
	COU61	O7		CCU60 output
135	P11.9	I	MP+ / PU1 / VFLEX	General-purpose input
	TIN98			GTM input
	MTSR1B			QSPI1 input
	RXDA1			ERAY input
	ETHRXD1			ETH input
	P11.9	O0		General-purpose output
	TOUT98	O1		GTM output
	–	O2		Reserved
	MTSR1	O3		QSPI1 output
	–	O4		Reserved
	SOP0	O5		MSC0 output
	–	O6		Reserved
	COU60	O7		CCU60 output

Package and Pinning Definitions TC264x Pin Definition and Functions:

Table 2-4 Port 11 Functions (cont'd)

Pin	Symbol	Ctrl	Type	Function
137	P11.10	I	LP / PU1 / VFLEX	General-purpose input
	TIN99			GTM input
	REQ12			SCU input
	ARX1E			ASCLIN1 input
	SLSI1A			QSPI1 input
	RXDCAN3D			CAN node 3 input
	RXDB1			ERAY input
	ETHRXD0			ETH input
	SDI00			MSC0 input
	P11.10	O0		General-purpose output
	TOUT99	O1		GTM output
	–	O2		Reserved
	SLSO03	O3		QSPI0 output
	SLSO13	O4		QSPI1 output
	–	O5		Reserved
	–	O6		Reserved
	CC62	O7		CCU60 output
138	P11.11	I	MP+ / PU1 / VFLEX	General-purpose input
	TIN100			GTM input
	ETHCRSDVA			ETH input
	P11.11	O0		General-purpose output
	TOUT100	O1		GTM output
	END02	O2		MSC0 output
	SLSO04	O3		QSPI0 output
	SLSO14	O4		QSPI1 output
	EN00	O5		MSC0 output
	TXENB	O6		ERAY output
	CC61	O7		CCU60 output

Package and Pinning Definitions TC264x Pin Definition and Functions:

Table 2-4 Port 11 Functions (cont'd)

Pin	Symbol	Ctrl	Type	Function
139	P11.12	I	MPR / PU1 / VFLEX	General-purpose input
	TIN101			GTM input
	ETHREFCLK			ETH input
	ETHTXCLKB			ETH input (Not for productive purposes)
	ETHRXCLKA			ETH input (Not for productive purposes)
	P11.12	O0		General-purpose output
	TOUT101	O1		GTM output
	ATX1	O2		ASCLIN1 output
	GTMCLK2	O3		GTM output
	TXDB	O4		ERAY output
	TXDCAN3	O5		CAN node 3 output
	EXTCLK1	O6		SCU output
	CC60	O7		CCU60 output

Table 2-5 Port 13 Functions

Pin	Symbol	Ctrl	Type	Function
128	P13.0	I	LVDSM_N / PU1 / VEXT	General-purpose input
	TIN91			GTM input
	P13.0	O0		General-purpose output
	TOUT91	O1		GTM output
	END03	O2		MSC0 output
	SCLK2N	O3		QSPI2 output (LVDS)
	EN01	O4		MSC0 output
	FCLN0	O5		MSC0 output (LVDS)
	FCLND0	O6		MSC0 output (LVDS)
	TXDCAN4	O7		CAN node 4 output

Package and Pinning Definitions TC264x Pin Definition and Functions:

Table 2-5 Port 13 Functions (cont'd)

Pin	Symbol	Ctrl	Type	Function
129	P13.1	I	LVDSM_P / PU1 / VEXT	General-purpose input
	TIN92			GTM input
	SCL0B			I2C0 input
	RXDCAN4C			CAN node 4 input
	P13.1	O0		General-purpose output
	TOUT92	O1		GTM output
	–	O2		Reserved
	SCLK2P	O3		QSPI2 output (LVDS)
	–	O4		Reserved
	FCLP0	O5		MSC0 output (LVDS)
	SCL0	O6		I2C0 output
	–	O7		Reserved
	130	P13.2		I
TIN93		GTM input		
CAPINA		GPT120 input		
SDA0B		I2C0 input		
P13.2		O0	General-purpose output	
TOUT93		O1	GTM output	
–		O2	Reserved	
MUSR2N		O3	QSPI2 output (LVDS)	
FCLP0		O4	MSC0 output	
SON0		O5	MSC0 output (LVDS)	
SDA0		O6	I2C0 output	
SOND0		O7	MSC0 output (LVDS)	
131		P13.3	I	LVDSM_P / PU1 / VEXT
	TIN94	GTM input		
	P13.3	O0	General-purpose output	
	TOUT94	O1	GTM output	
	–	O2	Reserved	
	MUSR2P	O3	QSPI2 output (LVDS)	
	–	O4	Reserved	
	SOP0	O5	MSC0 output (LVDS)	
	–	O6	Reserved	
	–	O7	Reserved	

Package and Pinning Definitions TC264x Pin Definition and Functions:

Table 2-6 Port 14 Functions

Pin	Symbol	Ctrl	Type	Function
118	P14.0	I	MP+ / PU1 / VEXT	General-purpose input
	TIN80			GTM input
	P14.0	O0		General-purpose output
	TOUT80	O1		GTM output
	ATX0	O2		ASCLIN0 output Recommended as Boot loader pin.
	TXDA	O3		ERAY output
	TXDB	O4		ERAY output
	TXDCAN1	O5		CAN node 1 output Used for single pin DAP (SPD) function.
	ASCLK0	O6		ASCLIN0 output
	COU62	O7		CCU60 output
119	P14.1	I	MP / PU1 / VEXT	General-purpose input
	TIN81			GTM input
	REQ15			SCU input
	ARX0A			ASCLIN0 input
	RXDCAN1B			CAN node 1 input Used for single pin DAP (SPD) function.
	RXDA3			ERAY input
	RXDB3			ERAY input
	EVRWUPA			SCU input
	P14.1	O0		General-purpose output
	TOUT81	O1		GTM output
	ATX0	O2		ASCLIN0 output Recommended as Boot loader pin.
	–	O3		Reserved
	–	O4		Reserved
	–	O5		Reserved
	–	O6		Reserved
	COU63	O7		CCU60 output

Package and Pinning Definitions TC264x Pin Definition and Functions:

Table 2-6 Port 14 Functions (cont'd)

Pin	Symbol	Ctrl	Type	Function
120	P14.2	I	LP / PU1 / VEXT	General-purpose input
	TIN82			GTM input
	HWCFG2 EVR13			SCU input Latched at cold power on reset to decide EVR13 activation.
	P14.2	O0		General-purpose output
	TOUT82	O1		GTM output
	ATX2	O2		ASCLIN2 output
	SLSO21	O3		QSPI2 output
	–	O4		Reserved
	–	O5		Reserved
	ASCLK2	O6		ASCLIN2 output
–	O7	Reserved		
121	P14.3	I	LP / PU1 / VEXT	General-purpose input
	TIN83			GTM input
	ARX2A			ASCLIN2 input
	REQ10			SCU input
	HWCFG3_BMI			SCU input
	SDI02			MSC0 input
	P14.3	O0		General-purpose output
	TOUT83	O1		GTM output
	ATX2	O2		ASCLIN2 output
	SLSO23	O3		QSPI2 output
	ASLSO1	O4		ASCLIN1 output
	ASLSO3	O5		ASCLIN3 output
	–	O6		Reserved
	–	O7		Reserved

Package and Pinning Definitions TC264x Pin Definition and Functions:

Table 2-6 Port 14 Functions (cont'd)

Pin	Symbol	Ctrl	Type	Function
122	P14.4	I	LP / PU1 / VEXT	General-purpose input
	TIN84			GTM input
	HWCFG6			SCU input Latched at cold power on reset to decide default pad reset state (PU or HighZ).
	P14.4	O0		General-purpose output
	TOUT84	O1		GTM output
	–	O2		Reserved
	–	O3		Reserved
	–	O4		Reserved
	–	O5		Reserved
	–	O6		Reserved
–	O7	Reserved		
123	P14.5	I	MP+ / PU1 / VEXT	General-purpose input
	TIN85			GTM input
	HWCFG1 EVR33			SCU input Latched at cold power on reset to decide EVR33 activation.
	P14.5	O0		General-purpose output
	TOUT85	O1		GTM output
	–	O2		Reserved
	–	O3		Reserved
	–	O4		Reserved
	–	O5		Reserved
	TXDB	O6		ERAY output
–	O7	Reserved		
124	P14.6	I	MP+ / PU1 / VEXT	General-purpose input
	TIN86			GTM input
	HWCFG0 DCLDO			SCU input If EVR13 active, latched at cold power on reset to decide between LDO and SMPS mode.
	P14.6	O0		General-purpose output
	TOUT86	O1		GTM output
	–	O2		Reserved
	SLSO22	O3		QSPI2 output
	–	O4		Reserved
	–	O5		Reserved
	TXENB	O6		ERAY output
–	O7	Reserved		

Package and Pinning Definitions TC264x Pin Definition and Functions:

Table 2-7 Port 15 Functions

Pin	Symbol	Ctrl	Type	Function
109	P15.0	I	LP / PU1 / VEXT	General-purpose input
	TIN71			GTM input
	P15.0	O0		General-purpose output
	TOUT71	O1		GTM output
	ATX1	O2		ASCLIN1 output
	SLSO013	O3		QSPI0 output
	–	O4		Reserved
	TXDCAN2	O5		CAN node 2 output
	ASCLK1	O6		ASCLIN1 output
	–	O7		Reserved
110	P15.1	I	LP / PU1 / VEXT	General-purpose input
	TIN72			GTM input
	REQ16			SCU input
	ARX1A			ASCLIN1 input
	RXDCAN2A			CAN node 2 input
	SLSI2B			QSPI2 input
	EVRWUPB			SCU input
	P15.1	O0		General-purpose output
	TOUT72	O1		GTM output
	ATX1	O2		ASCLIN1 output
	SLSO25	O3		QSPI2 output
	–	O4		Reserved
	–	O5		Reserved
	–	O6		Reserved
	–	O7		Reserved
111	P15.2	I	MP / PU1 / VEXT	General-purpose input
	TIN73			GTM input
	SLSI2A			QSPI2 input
	MRST2E			QSPI2 input
	HSIC2INA			QSPI2 input
	P15.2	O0		General-purpose output
	TOUT73	O1		GTM output
	ATX0	O2		ASCLIN0 output
	SLSO20	O3		QSPI2 output
	–	O4		Reserved
	TXDCAN1	O5		CAN node 1 output
	ASCLK0	O6		ASCLIN0 output
	–	O7		Reserved

Package and Pinning Definitions TC264x Pin Definition and Functions:

Table 2-7 Port 15 Functions (cont'd)

Pin	Symbol	Ctrl	Type	Function
112	P15.3	I	MP / PU1 / VEXT	General-purpose input
	TIN74			GTM input
	ARX0B			ASCLIN0 input
	SCLK2A			QSPI2 input
	RXDCAN1A			CAN node 1 input
	HSIC2INB			QSPI2 input
	P15.3	O0		General-purpose output
	TOUT74	O1		GTM output
	ATX0	O2		ASCLIN0 output
	SCLK2	O3		QSPI2 output
	END03	O4		MSC0 output
	EN01	O5		MSC0 output
	–	O6		Reserved
	–	O7		Reserved
113	P15.4	I	MP / PU1 / VEXT	General-purpose input
	TIN75			GTM input
	MRST2A			QSPI2 input
	REQ0			SCU input
	SCL0C			I2C0 input
	P15.4	O0		General-purpose output
	TOUT75	O1		GTM output
	ATX1	O2		ASCLIN1 output
	MRST2	O3		QSPI2 output
	–	O4		Reserved
	–	O5		Reserved
	SCL0	O6		I2C0 output
	CC62	O7		CCU60 output

Package and Pinning Definitions TC264x Pin Definition and Functions:

Table 2-7 Port 15 Functions (cont'd)

Pin	Symbol	Ctrl	Type	Function
114	P15.5	I	MP / PU1 / VEXT	General-purpose input
	TIN76			GTM input
	ARX1B			ASCLIN1 input
	M TSR2A			QSPI2 input
	SDA0C			I2C0 input
	REQ13			SCU input
	P15.5			O0
	TOUT76	O1		GTM output
	ATX1	O2		ASCLIN1 output
	M TSR2	O3		QSPI2 output
	END02	O4		MSC0 output
	EN00	O5		MSC0 output
	SDA0	O6		I2C0 output
	CC61	O7		CCU60 output
115	P15.6	I	MP / PU1 / VEXT	General-purpose input
	TIN77			GTM input
	M TSR2B			QSPI2 input
	P15.6	O0		General-purpose output
	TOUT77	O1		GTM output
	ATX3	O2		ASCLIN3 output
	M TSR2	O3		QSPI2 output
	–	O4		Reserved
	SCLK2	O5		QSPI2 output
	ASCLK3	O6		ASCLIN3 output
	CC60	O7		CCU60 output
116	P15.7	I	MP / PU1 / VEXT	General-purpose input
	TIN78			GTM input
	ARX3A			ASCLIN3 input
	MRST2B			QSPI2 input
	P15.7	O0		General-purpose output
	TOUT78	O1		GTM output
	ATX3	O2		ASCLIN3 output
	MRST2	O3		QSPI2 output
	–	O4		Reserved
	–	O5		Reserved
	–	O6		Reserved
	COUT60	O7		CCU60 output

Package and Pinning Definitions TC264x Pin Definition and Functions:

Table 2-7 Port 15 Functions (cont'd)

Pin	Symbol	Ctrl	Type	Function
117	P15.8	I	MP / PU1 / VEXT	General-purpose input
	TIN79			GTM input
	SCLK2B			QSPI2 input
	REQ1			SCU input
	P15.8	O0		General-purpose output
	TOUT79	O1		GTM output
	–	O2		Reserved
	SCLK2	O3		QSPI2 output
	–	O4		Reserved
	–	O5		Reserved
	ASCLK3	O6		ASCLIN3 output
	COU61	O7		CCU60 output

Table 2-8 Port 20 Functions

Pin	Symbol	Ctrl	Type	Function
93	P20.0	I	MP / PU1 / VEXT	General-purpose input
	TIN59			GTM input
	RXDCAN3C			CAN node 3 input
	T6EUDA			GPT120 input
	REQ9			SCU input
	SYSCLK			HSCT input
	TGI0			OCDS input
	P20.0	O0		General-purpose output
	TOUT59	O1		GTM output
	ATX3	O2		ASCLIN3 output
	ASCLK3	O3		ASCLIN3 output
	–	O4		Reserved
	SYSCLK	O5		HSCT output
	–	O6		Reserved
	–	O7		Reserved
	TGO0	HWOUT		OCDS; ENx

Package and Pinning Definitions TC264x Pin Definition and Functions:

Table 2-8 Port 20 Functions (cont'd)

Pin	Symbol	Ctrl	Type	Function
94	P20.2	I	LP / PU / VEXT	General-purpose input This pin is latched at power on reset release to enter test mode.
	TESTMODE			OCDS input
	P20.2	O0		Output function not available
	–	O1		Output function not available
	–	O2		Output function not available
	–	O3		Output function not available
	–	O4		Output function not available
	–	O5		Output function not available
	–	O6		Output function not available
	–	O7		Output function not available
95	P20.3	I	LP / PU1 / VEXT	General-purpose input
	TIN61			GTM input
	T6INA			GPT120 input
	ARX3C			ASCLIN3 input
	P20.3	O0		General-purpose output
	TOUT61	O1		GTM output
	ATX3	O2		ASCLIN3 output
	SLSO09	O3		QSPI0 output
	SLSO29	O4		QSPI2 output
	TXDCAN3	O5		CAN node 3 output
	–	O6		Reserved
	–	O7		Reserved
100	P20.6	I	LP / PU1 / VEXT	General-purpose input
	TIN62			GTM input
	P20.6	O0		General-purpose output
	TOUT62	O1		GTM output
	ARTS1	O2		ASCLIN1 output
	SLSO08	O3		QSPI0 output
	SLSO28	O4		QSPI2 output
	–	O5		Reserved
	–	O6		Reserved
	–	O7		Reserved

Package and Pinning Definitions TC264x Pin Definition and Functions:

Table 2-8 Port 20 Functions (cont'd)

Pin	Symbol	Ctrl	Type	Function
101	P20.7	I	LP / PU1 / VEXT	General-purpose input
	TIN63			GTM input
	ACTS1A			ASCLIN1 input
	RXDCAN0B			CAN node 0 input
	P20.7	O0		General-purpose output
	TOUT63	O1		GTM output
	–	O2		Reserved
	–	O3		Reserved
	–	O4		Reserved
	–	O5		Reserved
	WDT1LCK	O6		SCU output
	COUT63	O7		CCU61 output
102	P20.8	I	MP / PU1 / VEXT	General-purpose input
	TIN64			GTM input
	P20.8	O0		General-purpose output
	TOUT64	O1		GTM output
	ASLSO1	O2		ASCLIN1 output
	SLSO00	O3		QSPI0 output
	SLSO10	O4		QSPI1 output
	TXDCAN0	O5		CAN node 0 output
	WDT0LCK	O6		SCU output
	CC60	O7		CCU61 output
103	P20.9	I	LP / PU1 / VEXT	General-purpose input
	TIN65			GTM input
	ARX1C			ASCLIN1 input
	RXDCAN3E			CAN node 3 input
	REQ11			SCU input
	SLSI0B			QSPI0 input
	P20.9			O0
	TOUT65	O1		GTM output
	–	O2		Reserved
	SLSO01	O3		QSPI0 output
	SLSO11	O4		QSPI1 output
	–	O5		Reserved
	WDTSLCK	O6		SCU output
	CC61	O7		CCU61 output

Package and Pinning Definitions TC264x Pin Definition and Functions:

Table 2-8 Port 20 Functions (cont'd)

Pin	Symbol	Ctrl	Type	Function
104	P20.10	I	MP / PU1 / VEXT	General-purpose input
	TIN66			GTM input
	P20.10			General-purpose output
	TOUT66	O1		GTM output
	ATX1	O2		ASCLIN1 output
	SLSO06	O3		QSPI0 output
	SLSO27	O4		QSPI2 output
	TXDCAN3	O5		CAN node 3 output
	ASCLK1	O6		ASCLIN1 output
	CC62	O7		CCU61 output
105	P20.11	I	MP / PU1 / VEXT	General-purpose input
	TIN67			GTM input
	SCLK0A			QSPI0 input
	P20.11	O0		General-purpose output
	TOUT67	O1		GTM output
	–	O2		Reserved
	SCLK0	O3		QSPI0 output
	–	O4		Reserved
	–	O5		Reserved
	–	O6		Reserved
	COU60	O7		CCU61 output
106	P20.12	I	MP / PU1 / VEXT	General-purpose input
	TIN68			GTM input
	MRST0A			QSPI0 input
	P20.12	O0		General-purpose output
	TOUT68	O1		GTM output
	–	O2		Reserved
	MRST0	O3		QSPI0 output
	MTSR0	O4		QSPI0 output
	–	O5		Reserved
	–	O6		Reserved
	COU61	O7		CCU61 output

Package and Pinning Definitions TC264x Pin Definition and Functions:

Table 2-8 Port 20 Functions (cont'd)

Pin	Symbol	Ctrl	Type	Function
107	P20.13	I	MP / PU1 / VEXT	General-purpose input
	TIN69			GTM input
	SLSIOA			QSPI0 input
	P20.13	O0		General-purpose output
	TOUT69	O1		GTM output
	–	O2		Reserved
	SLSO02	O3		QSPI0 output
	SLSO12	O4		QSPI1 output
	SCLK0	O5		QSPI0 output
	–	O6		Reserved
	COU62	O7		CCU61 output
108	P20.14	I	MP / PU1 / VEXT	General-purpose input
	TIN70			GTM input
	MTSR0A			QSPI0 input
	P20.14	O0		General-purpose output
	TOUT70	O1		GTM output
	–	O2		Reserved
	MTSR0	O3		QSPI0 output
	–	O4		Reserved
	–	O5		Reserved
	–	O6		Reserved
	–	O7		Reserved

Package and Pinning Definitions TC264x Pin Definition and Functions:

Table 2-9 Port 21 Functions

Pin	Symbol	Ctrl	Type	Function
84	P21.2	I	LVDSH_N/ PU1 / VDDP3	General-purpose input
	TIN53			GTM input
	MRST2CN			QSPI2 input (LVDS)
	MRST3FN			QSPI3 input (LVDS)
	EMGSTOPB			SCU input
	RXDN			HSCT input (LVDS)
	P21.2			O0
	TOUT53	O1		GTM output
	ASLSO3	O2		ASCLIN3 output
	–	O3		Reserved
	–	O4		Reserved
	ETHMDC	O5		ETH output
	–	O6		Reserved
	–	O7		Reserved
85	P21.3	I	LVDSH_P/ PU1 / VDDP3	General-purpose input
	TIN54			GTM input
	MRST2CP			QSPI2 input (LVDS)
	MRST3FP			QSPI3 input (LVDS)
	RXDP			HSCT input (LVDS)
	P21.3	O0		General-purpose output
	TOUT54	O1		GTM output
	–	O2		Reserved
	–	O3		Reserved
	–	O4		Reserved
	–	O5		Reserved
	–	O6		Reserved
	–	O7		Reserved
	ETHMDIOD	HWOUT		ETH input/output

Package and Pinning Definitions TC264x Pin Definition and Functions:

Table 2-9 Port 21 Functions (cont'd)

Pin	Symbol	Ctrl	Type	Function
86	P21.4	I	LVDSH_N/ PU1 / VDDP3	General-purpose input
	TIN55			GTM input
	P21.4	O0		General-purpose output
	TOUT55	O1		GTM output
	–	O2		Reserved
	–	O3		Reserved
	–	O4		Reserved
	–	O5		Reserved
	–	O6		Reserved
	–	O7		Reserved
	TXDN	O		HSCT output (LVDS)
87	P21.5	I	LVDSH_P/ PU1 / VDDP3	General-purpose input
	TIN56			GTM input
	P21.5	O0		General-purpose output
	TOUT56	O1		GTM output
	ASCLK3	O2		ASCLIN3 output
	–	O3		Reserved
	–	O4		Reserved
	–	O5		Reserved
	–	O6		Reserved
	–	O7		Reserved
	TXDP	O		HSCT output (LVDS)
88 ¹⁾	P21.6	I	A2 / PU / VDDP3	General-purpose input
	TIN57			GTM input
	ARX3F			ASCLIN3 input
	TGI2			OCDS input
	TDI			OCDS (JTAG) input
	T5EUUDA			GPT120 input
	P21.6			O0
	TOUT57	O1		GTM output
	ASLSO3	O2		ASCLIN3 output
	–	O3		Reserved
	–	O4		Reserved
	SYSCLK	O5		HSCT output
	–	O6		Reserved
	T3OUT	O7		GPT120 output
	TGO2	HWOUT		OCDS; ENx

Package and Pinning Definitions TC264x Pin Definition and Functions:

Table 2-9 Port 21 Functions (cont'd)

Pin	Symbol	Ctrl	Type	Function
90	P21.7	I	A2 / PU / VDDP3	General-purpose input
	TIN58			GTM input
	DAP2			OCDS (3-Pin DAP) input In the 3-Pin DAP mode this pin is used as DAP2. In the 2-PIN DAP mode this pin is used as P21.7 and controlled by the related port control logic.
	TGI3			OCDS input
	ETHRXERB			ETH input
	T5INA			GPT120 input
	P21.7			O0
	TOUT58	O1		GTM output
	ATX3	O2		ASCLIN3 output
	ASCLK3	O3		ASCLIN3 output
	–	O4		Reserved
	–	O5		Reserved
	–	O6		Reserved
	T6OUT	O7		GPT120 output
	TGO3	HWOU T		OCDS; ENx
	TDO			OCDS (JTAG); ENx The JTAG TDO function is overlaid with P21.7 via a double bond. In JTAG mode this pin is used as TDO, after power-on reset it is HighZ.
	DAP2			OCDS (DAP2); ENx In the 3-Pin DAP mode this pin is used as DAP2.

1) For an Emulation Device in a non Fusion Quad package this pin is used as VDDPSB (3.3V)

Table 2-10 Port 22 Functions

Pin	Symbol	Ctrl	Type	Function
74	P22.0	I	LVDSM_N / PU1 / VEXT	General-purpose input
	TIN47			GTM input
	MTSR3E			QSPI3 input
	P22.0	O0		General-purpose output
	TOUT47	O1		GTM output
	–	O2		Reserved
	MTSR3	O3		QSPI3 output
	SCLK3N	O4		QSPI3 output (LVDS)
	FCLN1	O5		MSC1 output (LVDS)
	FCLND1	O6		MSC1 output (LVDS)
	–	O7		Reserved

Package and Pinning Definitions TC264x Pin Definition and Functions:

Table 2-10 Port 22 Functions (cont'd)

Pin	Symbol	Ctrl	Type	Function
75	P22.1	I	LVDSM_P / PU1 / VEXT	General-purpose input
	TIN48			GTM input
	MRST3E			QSPI3 input
	P22.1	O0		General-purpose output
	TOUT48	O1		GTM output
	–	O2		Reserved
	MRST3	O3		QSPI3 output
	SCLK3P	O4		QSPI3 output (LVDS)
	FCLP1	O5		MSC1 output (LVDS)
	–	O6		Reserved
	–	O7		Reserved
76	P22.2	I	LVDSM_N / PU1 / VEXT	General-purpose input
	TIN49			GTM input
	SLSI3D			QSPI3 input
	P22.2	O0		General-purpose output
	TOUT49	O1		GTM output
	–	O2		Reserved
	SLSO312	O3		QSPI3 output
	MTR3N	O4		QSPI3 output (LVDS)
	SON1	O5		MSC1 output (LVDS)
	SOND1	O6		MSC1 output (LVDS)
	–	O7		Reserved
77	P22.3	I	LVDSM_P / PU1 / VEXT	General-purpose input
	TIN50			GTM input
	SCLK3E			QSPI3 input
	P22.3	O0		General-purpose output
	TOUT50	O1		GTM output
	–	O2		Reserved
	SCLK3	O3		QSPI3 output
	MTR3P	O4		QSPI3 output (LVDS)
	SOP1	O5		MSC1 output (LVDS)
	–	O6		Reserved
	–	O7		Reserved

Package and Pinning Definitions TC264x Pin Definition and Functions:

Table 2-11 Port 23 Functions

Pin	Symbol	Ctrl	Type	Function
73	P23.1	I	MP+ / PU1 / VEXT	General-purpose input
	TIN42			GTM input
	SDI10			MSC1 input
	P23.1	O0		General-purpose output
	TOUT42	O1		GTM output
	ARTS1	O2		ASCLIN1 output
	SLSO313	O3		QSPI3 output
	GTMCLK0	O4		GTM output
	–	O5		Reserved
	EXTCLK0	O6		SCU output
	–	O7		Reserved

Table 2-12 Port 32 Functions

Pin	Symbol	Ctrl	Type	Function
70	P32.0	I	LP / PX/ VEXT	General-purpose input
	TIN36			GTM input
	FDEST			PMU input
	VGATE1N			SMPS mode: analog output. External Pass Device gate control for EVR13
	P32.0	O0		General-purpose output
	TOUT36	O1		GTM output
	–	O2		Reserved
	–	O3		Reserved
	–	O4		Reserved
	–	O5		Reserved
	–	O6		Reserved
	–	O7		Reserved

Package and Pinning Definitions TC264x Pin Definition and Functions:

Table 2-12 Port 32 Functions (cont'd)

Pin	Symbol	Ctrl	Type	Function
72	P32.4	I	MP+ / PU1 / VEXT	General-purpose input
	TIN40			GTM input
	ACTS1B			ASCLIN1 input
	SDI12			MSC1 input
	P32.4	O0		General-purpose output
	TOUT40	O1		GTM output
	–	O2		Reserved
	END12	O3		MSC1 output
	GTMCLK1	O4		GTM output
	EN10	O5		MSC1 output
	EXTCLK1	O6		SCU output
	COU63	O7		CCU60 output

Table 2-13 Port 33 Functions

Pin	Symbol	Ctrl	Type	Function
60	P33.4	I	LP / PU1 / VEXT	General-purpose input
	TIN26			GTM input
	CTRAPC			CCU61 input
	DSITR0F			DSADC channel 0 input F
	P33.4	O0		General-purpose output
	TOUT26	O1		GTM output
	ARTS2	O2		ASCLIN2 output
	–	O3		Reserved
	PSITX1	O4		PSI5 output
	VADCEMUX12	O5		VADC output
	VADCG0BFL0	O6		VADC output
	–	O7		Reserved

Package and Pinning Definitions TC264x Pin Definition and Functions:

Table 2-13 Port 33 Functions (cont'd)

Pin	Symbol	Ctrl	Type	Function
61	P33.5	I	LP / PU1 / VEXT	General-purpose input
	TIN27			GTM input
	ACTS2B			ASCLIN2 input
	PSIRX2C			PSI5 input
	PSISRXC			PSI5-S input
	SENT5C			SENT input
	CCPOS2C			CCU61 input
	T4EUDB			GPT120 input
	DSCIN0B			DSADC channel 0 input B
	P33.5			O0
	TOUT27	O1		GTM output
	SLSO07	O2		QSPI0 output
	SLSO17	O3		QSPI1 output
	DSCOUT0	O4		DSADC channel 0 output
	VADCEMUX11	O5		VADC output
	VADCG0BFL1	O6		VADC output
	–	O7		Reserved
	62	P33.6		I
TIN28		GTM input		
SENT4C		SENT input		
CCPOS1C		CCU61 input		
T2EUDB		GPT120 input		
DSDIN0B		DSADC channel 0 input B		
DSITR2F		DSADC channel 2 input F		
P33.6		O0	General-purpose output	
TOUT28		O1	GTM output	
ASLSO2		O2	ASCLIN2 output	
–		O3	Reserved	
PSITX2		O4	PSI5 output	
VADCEMUX10		O5	VADC output	
VADCG0BFL2		O6	VADC output	
PSISTX		O7	PSI5-S output	

Package and Pinning Definitions TC264x Pin Definition and Functions:

Table 2-13 Port 33 Functions (cont'd)

Pin	Symbol	Ctrl	Type	Function
63	P33.7	I	LP / PU1 / VEXT	General-purpose input
	TIN29			GTM input
	RXDCAN0E			CAN node 0 input
	REQ8			SCU input
	CCPOS0C			CCU61 input
	T2INB			GPT120 input
	P33.7			O0
	TOUT29	O1		GTM output
	ASCLK2	O2		ASCLIN2 output
	SLSO37	O3		QSPI3 output
	–	O4		Reserved
	–	O5		Reserved
	VADCG0BFL3	O6		VADC output
	–	O7		Reserved
64	P33.8	I	MP / HighZ/ VEXT	General-purpose input
	TIN30			GTM input
	ARX2E			ASCLIN2 input
	EMGSTOPA			SCU input
	P33.8	O0		General-purpose output
	TOUT30	O1		GTM output
	ATX2	O2		ASCLIN2 output
	SLSO32	O3		QSPI3 output
	–	O4		Reserved
	TXDCAN0	O5		CAN node 0 output
	–	O6		Reserved
	COU62	O7		CCU61 output
	SMUFSP	HWOUT		SMU
65	P33.9	I	LP / PU1 / VEXT	General-purpose input
	TIN31			GTM input
	HSIC3INA			QSPI3 input
	P33.9	O0		General-purpose output
	TOUT31	O1		GTM output
	ATX2	O2		ASCLIN2 output
	SLSO31	O3		QSPI3 output
	ASCLK2	O4		ASCLIN2 output
	–	O5		Reserved
	–	O6		Reserved
	CC62	O7		CCU61 output

Package and Pinning Definitions TC264x Pin Definition and Functions:

Table 2-13 Port 33 Functions (cont'd)

Pin	Symbol	Ctrl	Type	Function
66	P33.10	I	MP / PU1 / VEXT	General-purpose input
	TIN32			GTM input
	SLSI3C			QSPI3 input
	HSIC3INB			QSPI3 input
	P33.10	O0		General-purpose output
	TOUT32	O1		GTM output
	SLSO16	O2		QSPI1 output
	SLSO311	O3		QSPI3 output
	ASLSO1	O4		ASCLIN1 output
	PSISCLK	O5		PSI5-S output
	–	O6		Reserved
	COUT61	O7		CCU61 output
67	P33.11	I	MP / PU1 / VEXT	General-purpose input
	TIN33			GTM input
	SCLK3D			QSPI3 input
	P33.11	O0		General-purpose output
	TOUT33	O1		GTM output
	ASCLK1	O2		ASCLIN1 output
	SCLK3	O3		QSPI3 output
	–	O4		Reserved
	–	O5		Reserved
	DSCGPWMN	O6		DSADC output
	CC61	O7		CCU61 output
68	P33.12	I	MP / PU1 / VEXT	General-purpose input
	TIN34			GTM input
	MTR3D			QSPI3 input
	P33.12	O0		General-purpose output
	TOUT34	O1		GTM output
	ATX1	O2		ASCLIN1 output
	MTR3	O3		QSPI3 output
	ASCLK1	O4		ASCLIN1 output
	–	O5		Reserved
	DSCGPWMP	O6		DSADC output
	COUT60	O7		CCU61 output

Package and Pinning Definitions TC264x Pin Definition and Functions:

Table 2-13 Port 33 Functions (cont'd)

Pin	Symbol	Ctrl	Type	Function
69	P33.13	I	MP / PU1 / VEXT	General-purpose input
	TIN35			GTM input
	ARX1F			ASCLIN1 input
	MRST3D			QSPI3 input
	DSSGNB			DSADC input
	INJ11			MSC1 input
	P33.13			O0
	TOUT35	O1		GTM output
	ATX1	O2		ASCLIN1 output
	MRST3	O3		QSPI3 output
	SLSO26	O4		QSPI2 output
	–	O5		Reserved
	DCDCSYNC	O6		SCU output
	CC60	O7		CCU61 output

Table 2-14 Port 40 Functions

Pin	Symbol	Ctrl	Type	Function
36	P40.0	I	S / HighZ / VDDM	General-purpose input
	VADCG1.8			VADC analog input channel 8 of group 1
	CCPOS0D			CCU60 input
	SENT0A			SENT input
35	P40.1	I	S / HighZ / VDDM	General-purpose input
	VADCG1.9			VADC analog input channel 9 of group 1 (MD)
	CCPOS1B			CCU60 input
	SENT1A			SENT input
33	P40.6	I	S / HighZ / VDDM	General-purpose input
	VADCG2.4			VADC analog input channel 4 of group 2
	DS3PA			DSADC: positive analog input of channel 3, pin A
	CCPOS1B			CCU61 input
	SENT2D			SENT input
32	P40.7	I	S / HighZ / VDDM	General-purpose input
	VADCG2.5			VADC analog input channel 5 of group 2
	DS3NA			DSADC: negative analog input channel of DSADC 3, pin A
	CCPOS1D			CCU61 input
	SENT3D			SENT input

Package and Pinning Definitions TC264x Pin Definition and Functions:

Table 2-14 Port 40 Functions (cont'd)

Pin	Symbol	Ctrl	Type	Function
31	P40.8	I	S / HighZ / VDDM	General-purpose input
	VADCG2.6			VADC analog input channel 6 of group 2
	DS3PB			DSADC: positive analog input of channel 3, pin B
	CCPOS2B			CCU61 input
	SENT4A			SENT input
30	P40.9	I	S / HighZ / VDDM	General-purpose input
	VADCG2.7			VADC analog input channel 7 of group 2
	DS3NB			DSADC: negative analog input channel of DSADC 3, pin B
	CCPOS2D			CCU61 input
	SENT5A			SENT input

Table 2-15 Analog Inputs

Pin	Symbol	Ctrl	Type	Function
57	AN0	I	D / HighZ / VDDM	Analog input 0
	VADCG0.0			VADC analog input channel 0 of group 0
	DS0PB			DSADC: positive analog input of channel 0, pin B
56	AN1	I	D / HighZ / VDDM	Analog input 1
	VADCG0.1			VADC analog input channel 1 of group 0 (MD)
	DS0NB			DSADC: negative analog input channel of DSADC 0, pin B
55	AN2	I	D / HighZ / VDDM	Analog input 2
	VADCG0.2			VADC analog input channel 2 of group 0 (MD)
	DS0PA			DSADC: positive analog input of channel 0, pin A
54	AN3	I	D / HighZ / VDDM	Analog input 3
	VADCG0.3			VADC analog input channel 3 of group 0
	DS0NA			DSADC: negative analog input channel of DSADC 0, pin A
53	AN4	I	D / HighZ / VDDM	Analog input 4
	VADCG0.4			VADC analog input channel 4 of group 0
52	AN5	I	D / HighZ / VDDM	Analog input 5
	VADCG0.5			VADC analog input channel 5 of group 0
51	AN6	I	D / HighZ / VDDM	Analog input 6
	VADCG0.6			VADC analog input channel 6 of group 0
50	AN7	I	D / HighZ / VDDM	Analog input 7
	VADCG0.7			VADC analog input channel 7 of group 0 (with pull down diagnostics)

Package and Pinning Definitions TC264x Pin Definition and Functions:

Table 2-15 Analog Inputs (cont'd)

Pin	Symbol	Ctrl	Type	Function
49	AN8	I	D / HighZ / VDDM	Analog input 8
	VADCG0.8			VADC analog input channel 8 of group 0
48	AN10	I	D / HighZ / VDDM	Analog input 10
	VADCG0.10			VADC analog input channel 10 of group 0 (MD)
47	AN11	I	D / HighZ / VDDM	Analog input 11
	VADCG0.11			VADC analog input channel 11 of group 0
46	AN12	I	D / HighZ / VDDM	Analog input 12
	VADCG0.12			VADC analog input channel 12 of group 0
45	AN13	I	D / HighZ / VDDM	Analog input 13
	VADCG0.13			VADC analog input channel 13 of group 0
40	AN16	I	D / HighZ / VDDM	Analog input 16
	VADCG1.0			VADC analog input channel 0 of group 1
39	AN17	I	D / HighZ / VDDM	Analog input 17
	VADCG1.1			VADC analog input channel 1 of group 1 (MD)
38	AN20	I	D / HighZ / VDDM	Analog input 20
	VADCG1.4			VADC analog input channel 4 of group 1
	DS2PA			DSADC: positive analog input of channel 2, pin A
37	AN21	I	D / HighZ / VDDM	Analog input 21
	VADCG1.5			VADC analog input channel 5 of group 1
	DS2NA			DSADC: negative analog input channel of DSADC 2, pin A
36	AN24	I	S / HighZ / VDDM	Analog input 24
	VADCG1.8			VADC analog input channel 8 of group 1
	SENT0A			SENT input channel 0, pin A
35	AN25	I	S / HighZ / VDDM	Analog input 24
	VADCG1.9			VADC analog input channel 9 of group 1 (MD)
	SENT1A			SENT input channel 1, pin A
34	AN35	I	D / HighZ / VDDM	Analog input 35
	VADCG2.3			VADC analog input channel 3 of group 2 (with pull down diagnostics)
33	AN36	I	S / HighZ / VDDM	Analog input 34
	VADCG2.4			VADC analog input channel 4 of group 2
	DS3PA			DSADC: positive analog input of channel 3, pin A
	SENT2D			SENT input channel 2, pin D

Package and Pinning Definitions TC264x Pin Definition and Functions:

Table 2-15 Analog Inputs (cont'd)

Pin	Symbol	Ctrl	Type	Function
32	AN37	I	S / HighZ / VDDM	Analog input 37
	VADCG2.5			VADC analog input channel 5 of group 2
	DS3NA			DSADC: negative analog input channel of DSADC 3, pin A
	SENT3D			SENT input channel 3, pin D
31	AN38	I	S / HighZ / VDDM	Analog input 38
	VADCG2.6			VADC analog input channel 6 of group 2
	DS3PB			DSADC: positive analog input of channel 3, pin B
	SENT4A			SENT input channel 4, pin A
30	AN39	I	S / HighZ / VDDM	Analog input 39
	VADCG2.7			VADC analog input channel 7 of group 2
	DS3NB			DSADC: negative analog input channel of DSADC 3, pin B
	SENT5A			SENT input channel 5, pin A
29	AN44	I	D / HighZ / VDDM	Analog input 44
	VADCG2.10			VADC analog input channel 10 of group 2 (MD)
	DS3PC			DSADC: positive analog input of channel 3, pin C
28	AN45	I	D / HighZ / VDDM	Analog input 45
	VADCG2.11			VADC analog input channel 11 of group 2
	DS3NC			DSADC: negative analog input channel of DSADC 3, pin C
27	AN46	I	D / HighZ / VDDM	Analog input 46
	VADCG2.12			VADC analog input channel 12 of group 24
	DS3PD			DSADC: positive analog input of channel 3, pin D
26	AN47	I	D / HighZ / VDDM	Analog input 47
	VADCG2.13			VADC analog input channel 13 of group 2
	DS3ND			DSADC: negative analog input channel of DSADC 3, pin D
25	AN48	I	D / HighZ / VDDM	Analog input 48
	VADCG2.14			VADC analog input channel 14 of group 2
24	AN49	I	D / HighZ / VDDM	Analog input 49
	VADCG2.15			VADC analog input channel 15 of group 2

Package and Pinning Definitions TC264x Pin Definition and Functions:

Table 2-16 System I/O

Pin	Symbol	Ctrl	Type	Function
97	PORST	I	PORST / PD / VEXT	Power On Reset Input Additional strong PD in case of power fail.
98	ESR0	I/O	MP / OD / VEXT	External System Request Reset 0 Default configuration during and after reset is open-drain driver. The driver drives low during power-on reset. This is valid additionally after deactivation of PORST until the internal reset phase has finished. See also SCU chapter for details. Default after power-on can be different. See also SCU chapter 'Reset Control Unit' and SCU_IOCR register description.
	EVRWUP	I		EVR Wakeup Pin
96	ESR1	I/O	MP / PU1 / VEXT	External System Request Reset 1 Default NMI function. See also SCU chapter 'Reset Control Unit' and SCU_IOCR register description.
	EVRWUP	I		EVR Wakeup Pin
71	VGATE1P	O	VGATE1P / - / VEXT	External Pass Device gate control for EVR13
89	TMS	I	A2 / PD / VDDP3	JTAG Module State Machine Control Input
	DAP1	I/O		Device Access Port Line 1
91	TRST	I	A2 / PD / VDDP3	JTAG Module Reset/Enable Input
92	TCK	I	A2 / PD / VDDP3	JTAG Module Clock Input
	DAP0	I		Device Access Port Line 0
81	XTAL1	I	XTAL1 / - / -	Main Oscillator/PLL/Clock Generator Input
82	XTAL2	O	XTAL2 / - / -	Main Oscillator/PLL/Clock Generator Output

Table 2-17 Supply

Pin	Symbol	Ctrl	Type	Function
42	VAREF1	I	Vx	Positive Analog Reference Voltage 1
41	VAGND1	I	Vx	Negative Analog Reference Voltage 1
44	VDDM	I	Vx	ADC Analog Power Supply (3.3V / 5V)

Package and Pinning Definitions TC264x Pin Definition and Functions:

Table 2-17 Supply (cont'd)

Pin	Symbol	Ctrl	Type	Function
10	VDD / VDDSB	I	Vx	Emulation Device: Emulation SRAM Standby Power Supply (1.3V) (Emulation Device only). Production Device: VDD (1.3V).
99, 58, 22	VDD	I	Vx	Digital Core Power Supply (1.3V)
79	VDD	I	Vx	Digital Core Power Supply (1.3V). The supply pin inturn supplies the main XTAL Oscillator/PLL (1.3V) . A higher decoupling capacitor is therefore recommended to the VSS pin for better noise immunity.
125, 78, 59, 23	VEXT	I	Vx	External Supply (5V / 3.3V)
126	VDDP3	I	Vx	Digital Power Supply for Flash (3.3V). Can be also used as external 3.3V Power Supply for VFLEX.
83	VDDP3	I	Vx	Digital Power Supply for Oscillator, LVDSH and A2 pads (3.3V). The supply pin inturn supplies the main XTAL Oscillator/PLL (3.3V) . A higher decoupling capacitor is therefore recommended to the VSS pin for better noise immunity.
127	VDDFL3	I	Vx	Flash Power Supply (3.3V)
136	VFLEX	I	Vx	Digital Power Supply for Flex Port Pads (5V / 3.3V)
80	VSS	I	Vx	Digital Ground
43	VSSM	I	Vx	Analog Ground for V _{DDM}

Legend:

Column "Ctrl.":

 I = Input (for GPIO port Lines with IOCR bit field Selection PC_x = 0XXX_B)

O = Output

 O0 = Output with IOCR bit field selection PC_x = 1X000_B

 O1 = Output with IOCR bit field selection PC_x = 1X001_B (ALT1)

 O2 = Output with IOCR bit field selection PC_x = 1X010_B (ALT2)

 O3 = Output with IOCR bit field selection PC_x = 1X011_B (ALT3)

 O4 = Output with IOCR bit field selection PC_x = 1X100_B (ALT4)

 O5 = Output with IOCR bit field selection PC_x = 1X101_B (ALT5)

 O6 = Output with IOCR bit field selection PC_x = 1X110_B (ALT6)

 O7 = Output with IOCR bit field selection PC_x = 1X111_B (ALT7)

Column "Type":

LP = Pad class LP (5V/3.3V, LVTTTL)

MP = Pad class MP (5V/3.3V, LVTTTL)

MP+ = Pad class MP (5V/3.3V, LVTTTL)

A2 = Pad class A2 (3.3V, LVTTTL)

Package and Pinning Definitions TC264x Pin Definition and Functions:

LVDSM = Pad class LVDSM (LVDS/CMOS 5V/3.3V)

LVDSH = Pad class LVDSH (LVDS/CMOS 3.3V)

S = Pad class S (ADC overlay with General Purpose Input)

D = Pad class D (ADC)

PU = with pull-up device connected during reset ($\overline{\text{PORST}} = 0$)

PU1 = with pull-up device connected during reset ($\overline{\text{PORST}} = 0$)^{1) 2) 3)}

PD = with pull-down device connected during reset ($\overline{\text{PORST}} = 0$)

PD1 = with pull-down device connected during reset ($\overline{\text{PORST}} = 0$)^{1) 2) 3)}

PX = Behavior depends on usage: PD in EVR13 SMPS Mode and PU1 in GPIO Mode

OD = open drain during reset ($\overline{\text{PORST}} = 0$)

HighZ = tri-state during reset ($\overline{\text{PORST}} = 0$)

PORST = PORST input pad

XTAL1 = XTAL1 input pad

XTAL2 = XTAL2 input pad

VGATE1P = VGATE1P

VGATE3P = VGATE3P

Vx = Supply (the Exposed Pad is also considered as VSS and shall be connected to ground)

NC = These pins are reserved for future extensions and shall not be connected externally

NC1 = These pins are not connected on package level and will not be used for future extensions

NCVDDPSB = This pin has a different functionality in an Production Device and an Emulation Device. For details pls. see Pin/Ball description of this pin.

NCVDDSB = This pin has a different functionality in an Production Device and an Emulation Device. For details pls. see Pin/Ball description of this pin.

2.1.2 Emergency Stop Function

The Emergency Stop function can be used to force GPIOs (General Purpose Inputs/Outputs) via an external input signal (EMGSTOPA or EMGSTOPB) into a defined state:

- Input state and
- PU or High-Z depending on HWCFG[6] level latched during $\overline{\text{PORST}}$ active

Control of the Emergency Stop function:

- The Emergency Stop function can be enabled/disabled in the SCU (see chapter "SCU", "Emergency Stop Control")
- The Emergency Stop input signal, EMGSTOPA (P33.8) / EMGSTOPB (P21.2), can be selected in the SCU (see chapter "SCU", "Emergency Stop Control")
- On port level, each GPIO can be enabled/disabled for the Emergency Stop function via the Px_ESR (Port x Emergency Stop) registers in the port control logic (see chapter "General Purpose I/O Ports and Peripheral I/O Lines", "Emergency Stop Register").

The Emergency Stop function is available for all GPIO Ports with the following exceptions:

- Not available for P20.2 (General Purpose Input/GPI only, overlaid with Testmode)
- Not available for P40.x (analog input ANx overlaid with GPI)
- Not available for P32.0 EVR13 SMPS mode.

1) The default state of GPIOs (Px.y) during and after $\overline{\text{PORST}}$ active is controlled via HWCFG[6] (P14.4). HWCFG[6] has a weak internal pull-up active at start-up if the pin is left unconnected. See also User's Manual, "Introduction Chapter", "General Purpose I/O Ports and Peripheral I/O Lines", Figure: "Default state of port pins during and after reset".

2) If HWCFG[6] is left unconnected or is externally pulled high, weak internal pull-ups (PU1) / pull-downs (PD1) are active during and after reset.

3) If HWCFG[6] is connected to ground, the PD1 / PU1 pins are predominantly in HighZ during and after reset.

Package and Pinning Definitions TC264x Pin Definition and Functions:

- Not available for dedicated I/O without General Purpose Output function (e.g ESRx, TMS, TCK)

The Emergency Stop function can be overruled on the following GPIO Ports:

- P00.x and P02.x: Emergency Stop can be overruled by the 8-Bit Standby Controller (SBR), if implemented. Overruling can be disabled via the control registers P00_SCR / P02_SCR (see chapter “General Purpose I/O Ports and Peripheral I/O Lines”, P00 / P01)
- P00.x: Emergency Stop can be overruled by the VADC. Overruling can be disabled via the control register P00_SCR (see chapter “General Purpose I/O Ports and Peripheral I/O Lines”, P00)
- P14.0 and P14.1: Emergency Stop can be overruled in the DXCPL mode (DAP over can physical layer mode). No Overruling in the DXCM (Debug over can message) mode
- P21.6: Emergency Stop can be overruled in JTAG mode if this pin is used as TDI
- P21.7: Emergency Stop can be overruled in JTAG or Three Pin DAP mode
- P20.0: Emergency Stop can be overruled in JTAG mode if this GPIO is used as TDI

2.1.3 Pull-Up/Pull-Down Reset Behavior of the Pins

Table 2-18 List of Pull-Up/Pull-Down Reset Behavior of the Pins

Pins	$\overline{\text{PORST}} = 0$	$\overline{\text{PORST}} = 1$
all GPIOs	Pull-up if HWCFG[6] = 1 or High-Z if HWCFG[6] = 0	
$\overline{\text{TDI}}$, $\overline{\text{TESTMODE}}$	Pull-up	
$\overline{\text{PORST}}^{1)}$	Pull-down with I_{PORST} relevant	Pull-down with I_{PDLI} relevant
$\overline{\text{TRST}}$, TCK, TMS	Pull-down	
ESR0	The open-drain driver is used to drive low. ²⁾	Pull-up ³⁾
ESR1	Pull-up ³⁾	
TDO	Pull-up	High-Z/Pull-up ⁴⁾

1) Pull-down with I_{PORST} relevant is always activated when a primary supply monitor detects a violation.

2) Valid additionally after deactivation of $\overline{\text{PORST}}$ until the internal reset phase has finished. See the SCU chapter for details.

3) See the SCU_IOCRR register description.

4) Depends on JTAG/DAP selection with $\overline{\text{TRST}}$.

In case of leakage test ($\overline{\text{PORST}} = 0$ and $\overline{\text{TESTMODE}} = 0$), the pull-down of the $\overline{\text{TRST}}$ pin is switched off. In case of an user application ($\overline{\text{TESTMODE}} = 1$), the pull-down of the $\overline{\text{TRST}}$ is always switched on.

Package and Pinning Definitions TC265x Pin Definition and Functions:

2.2 TC265x Pin Definition and Functions: LQFP176

Figure 2-1 is showing the TC265x Logic Symbol for the package variant: QFP176.

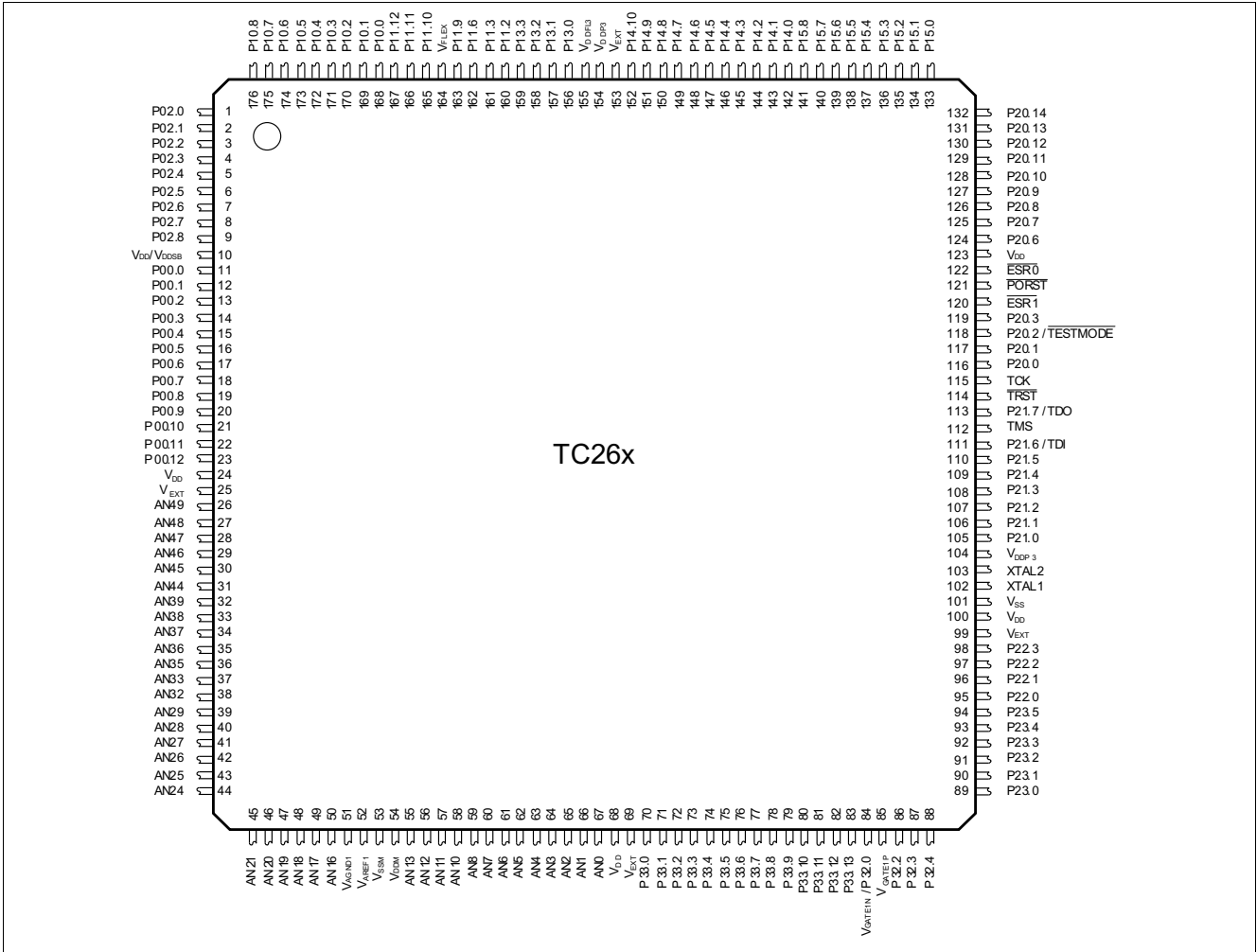

Figure 2-2 TC265x Logic Symbol for the package variant LQFP176.

2.2.1 TC265 LQFP176 Package Variant Pin Configuration

Table 2-19 Port 00 Functions

Pin	Symbol	Ctrl	Type	Function
11	P00.0	I	MP / PU1 / VEXT	General-purpose input
	TIN9			GTM input
	CTRAPA			CCU61 input
	T12HRE			CCU60 input
	INJ00			MSC0 input
	CIFD9			CIF input
	P00.0	O0		General-purpose output
	TOUT9	O1		GTM output
	ASCLK3	O2		ASCLIN3 output
	ATX3	O3		ASCLIN3 output
	–	O4		Reserved
	TXDCAN1	O5		CAN node 1 output
	–	O6		Reserved
	COU63	O7		CCU60 output
	ETHMDIOA	I/O		ETH input/output
	12	P00.1		I
TIN10		GTM input		
ARX3E		ASCLIN3 input		
RXDCAN1D		CAN node 1 input		
PSIRX0A		PSI5 input		
SENT0B		SENT input		
CC60INB		CCU60 input		
CC60INA		CCU61 input		
DSCIN0A		DSADC channel 0 input A		
VADCG3.11		VADC analog input channel 11 of group 3		
CIFD10		CIF input		
P00.1		O0	General-purpose output	
TOUT10		O1	GTM output	
ATX3		O2	ASCLIN3 output	
–		O3	Reserved	
DSCOUT0		O4	DSADC channel 0 output	
–	O5	Reserved		
SPC0	O6	SENT output		
CC60	O7	CCU61 output		

Package and Pinning Definitions TC265x Pin Definition and Functions:

Table 2-19 Port 00 Functions (cont'd)

Pin	Symbol	Ctrl	Type	Function
13	P00.2	I	LP / PU1 / VEXT	General-purpose input
	TIN11			GTM input
	SENT1B			SENT input
	DSDIN0A			DSADC channel 0 input A
	VADCG3.10			VADC analog input channel 10 of group 3 (MD)
	CIFD11			CIF input
	P00.2			O0
	TOUT11	O1		GTM output
	ASCLK3	O2		ASCLIN3 output
	–	O3		Reserved
	PSITX0	O4		PSI5 output
	TXDCAN3	O5		CAN node 3 output
	–	O6		Reserved
	COOUT60	O7		CCU61 output
14	P00.3	I	LP / PU1 / VEXT	General-purpose input
	TIN12			GTM input
	RXDCAN3A			CAN node 3 input
	PSIRX1A			PSI5 input
	PSISRXA			PSI5-S input
	SENT2B			SENT input
	CC61INB			CCU60 input
	CC61INA			CCU61 input
	DSCIN3A			DSADC channel 3 input A
	VADCG3.9			VADC analog input channel 9 of group 3 (MD)
	CIFD12			CIF input
	P00.3			O0
	TOUT12	O1		GTM output
	ASLSO3	O2		ASCLIN3 output
	–	O3		Reserved
	DSCOUT3	O4		DSADC channel 3 output
	–	O5		Reserved
	SPC2	O6		SENT output
CC61	O7	CCU61 output		

Package and Pinning Definitions TC265x Pin Definition and Functions:

Table 2-19 Port 00 Functions (cont'd)

Pin	Symbol	Ctrl	Type	Function
15	P00.4	I	LP / PU1 / VEXT	General-purpose input
	TIN13			GTM input
	REQ7			SCU input
	SENT3B			SENT input
	DSDIN3A			DSADC channel 3 input A
	DSSGNA			DSADC input
	VADCG3.8			VADC analog input channel 8 of group 3
	CIFD13			CIF input
	P00.4			O0
	TOUT13	O1		GTM output
	PSISTX	O2		PSI5-S output
	TXDCAN4	O3		CAN node 4 output
	PSITX1	O4		PSI5 output
	VADCG2BFL0	O5		VADC output
	SPC3	O6		SENT output
	COU61	O7		CCU61 output
	16	P00.5		I
TIN14		GTM input		
PSIRX2A		PSI5 input		
SENT4B		SENT input		
RXDCAN4A		CAN node 4 input		
CC62INB		CCU60 input		
CC62INA		CCU61 input		
DSCIN2A		DSADC channel 2 input A		
VADCG3.7		VADC analog input channel 7 of group 3		
CIFD14		CIF input		
P00.5		O0	General-purpose output	
TOUT14		O1	GTM output	
DSCGPWMN		O2	DSADC output	
–		O3	Reserved	
DSCOUT2		O4	DSADC channel 2 output	
VADCG2BFL1		O5	VADC output	
SPC4		O6	SENT output	
CC62	O7	CCU61 output		

Package and Pinning Definitions TC265x Pin Definition and Functions:

Table 2-19 Port 00 Functions (cont'd)

Pin	Symbol	Ctrl	Type	Function
17	P00.6	I	LP / PU1 / VEXT	General-purpose input
	TIN15			GTM input
	SENT5B			SENT input
	DSDIN2A			DSADC channel 2 input A
	VADCG3.6			VADC analog input channel 6 of group 3
	CIFD15			CIF input
	P00.6	O0		General-purpose output
	TOUT15	O1		GTM output
	DSCGPWMP	O2		DSADC output
	VADCG2BFL2	O3		VADC output
	PSITX2	O4		PSI5 output
	VADCEMUX10	O5		VADC output
	SPC5	O6		SENT output
	COU62	O7		CCU61 output
18	P00.7	I	LP / PU1 / VEXT	General-purpose input
	TIN16			GTM input
	CC60INC			CCU61 input
	CCPOS0A			CCU61 input
	T12HRB			CCU60 input
	T2INA			GPT120 input
	VADCG3.5			VADC analog input channel 5 of group 3
	CIFCLK			CIF input
	P00.7	O0		General-purpose output
	TOUT16	O1		GTM output
	–	O2		Reserved
	VADCG2BFL3	O3		VADC output
	–	O4		Reserved
	VADCEMUX11	O5		VADC output
	–	O6		Reserved
	CC60	O7		CCU61 output

Package and Pinning Definitions TC265x Pin Definition and Functions:

Table 2-19 Port 00 Functions (cont'd)

Pin	Symbol	Ctrl	Type	Function
19	P00.8	I	LP / PU1 / VEXT	General-purpose input
	TIN17			GTM input
	CC61INC			CCU61 input
	CCPOS1A			CCU61 input
	T13HRB			CCU60 input
	T2EUDA			GPT120 input
	VADCG3.4			VADC analog input channel 4 of group 3
	CIFVSNC			CIF input
	P00.8			O0
	TOUT17	O1		GTM output
	SLSO36	O2		QSPI3 output
	–	O3		Reserved
	–	O4		Reserved
	VADCEMUX12	O5		VADC output
	–	O6		Reserved
	CC61	O7		CCU61 output
20	P00.9	I	LP / PU1 / VEXT	General-purpose input
	TIN18			GTM input
	CC62INC			CCU61 input
	CCPOS2A			CCU61 input
	T13HRC			CCU60 input
	T12HRC			CCU60 input
	T4EUDA			GPT120 input
	VADCG3.3			VADC analog input channel 3 of group 3
	DSITR3F			DSADC channel 3 input F
	CIFHSNC	CIF input		
	P00.9	O0		General-purpose output
	TOUT18	O1		GTM output
	SLSO37	O2		QSPI3 output
	ARTS3	O3		ASCLIN3 output
	–	O4		Reserved
	–	O5		Reserved
–	O6	Reserved		
CC62	O7	CCU61 output		

Package and Pinning Definitions TC265x Pin Definition and Functions:

Table 2-19 Port 00 Functions (cont'd)

Pin	Symbol	Ctrl	Type	Function
21	P00.10	I	LP / PU1 / VEXT	General-purpose input
	TIN19			GTM input
	VADCG3.2			VADC analog input channel 2 of group 3 (MD)
	P00.10	O0		General-purpose output
	TOUT19	O1		GTM output
	–	O2		Reserved
	–	O3		Reserved
	–	O4		Reserved
	–	O5		Reserved
	–	O6		Reserved
	COU63	O7		CCU61 output
22	P00.11	I	LP / PU1 / VEXT	General-purpose input
	TIN20			GTM input
	CTRAPA			CCU60 input
	T12HRE			CCU61 input
	VADCG3.1			VADC analog input channel of group 3
	P00.11	O0		General-purpose output
	TOUT20	O1		GTM output
	–	O2		Reserved
	–	O3		Reserved
	DSCOUT0	O4		DSADC channel 0 output
	–	O5		Reserved
	–	O6		Reserved
	–	O7		Reserved
	23	P00.12		I
TIN21		GTM input		
ACTS3A		ASCLIN3 input		
VADCG3.0		VADC analog input channel 0 of group 3		
P00.12		O0	General-purpose output	
TOUT21		O1	GTM output	
–		O2	Reserved	
–		O3	Reserved	
–		O4	Reserved	
–		O5	Reserved	
–		O6	Reserved	
COU63		O7	CCU61 output	

Package and Pinning Definitions TC265x Pin Definition and Functions:

Table 2-20 Port 02 Functions

Pin	Symbol	Ctrl	Type	Function
1	P02.0	I	MP+ / PU1 / VEXT	General-purpose input
	TIN0			GTM input
	ARX2G			ASCLIN2 input
	REQ6			SCU input
	CC60INA			CCU60 input
	CC60INB			CCU61 input
	CIFD0			CIF input
	P02.0			O0
	TOUT0	O1		GTM output
	ATX2	O2		ASCLIN2 output
	SLSO31	O3		QSPI3 output
	DSCGPWMN	O4		DSADC output
	TXDCAN0	O5		CAN node 0 output
	TXDA	O6		ERAY output
	CC60	O7		CCU60 output
	2	P02.1		I
TIN1		GTM input		
REQ14		SCU input		
ARX2B		ASCLIN2 input		
RXDCAN0A		CAN node 0 input		
RXDA2		ERAY input		
CIFD1		CIF input		
P02.1		O0	General-purpose output	
TOUT1		O1	GTM output	
–		O2	Reserved	
SLSO32		O3	QSPI3 output	
DSCGPWMP		O4	DSADC output	
–		O5	Reserved	
–		O6	Reserved	
COUT60		O7	CCU60 output	

Package and Pinning Definitions TC265x Pin Definition and Functions:

Table 2-20 Port 02 Functions (cont'd)

Pin	Symbol	Ctrl	Type	Function
3	P02.2	I	MP+ / PU1 / VEXT	General-purpose input
	TIN2			GTM input
	CC61INA			CCU60 input
	CC61INB			CCU61 input
	CIFD2			CIF input
	P02.2	O0		General-purpose output
	TOUT2	O1		GTM output
	ATX1	O2		ASCLIN1 output
	SLSO33	O3		QSPI3 output
	PSITX0	O4		PSI5 output
	TXDCAN2	O5		CAN node 2 output
	TXDB	O6		ERAY output
	CC61	O7		CCU60 output
	4	P02.3		I
TIN3		GTM input		
ARX1G		ASCLIN1 input		
RXDCAN2B		CAN node 2 input		
RXDB2		ERAY input		
PSIRX0B		PSI5 input		
SDI11		MSC1 input		
CIFD3		CIF input		
P02.3		O0	General-purpose output	
TOUT3		O1	GTM output	
ASLSO2		O2	ASCLIN2 output	
SLSO34		O3	QSPI3 output	
–		O4	Reserved	
–		O5	Reserved	
–		O6	Reserved	
COUT61		O7	CCU60 output	

Package and Pinning Definitions TC265x Pin Definition and Functions:

Table 2-20 Port 02 Functions (cont'd)

Pin	Symbol	Ctrl	Type	Function
5	P02.4	I	MP+ / PU1 / VEXT	General-purpose input
	TIN4			GTM input
	SLSI3A			QSPI3 input
	ECTT1			TTCAN input
	RXDCAN0D			CAN node 0 input
	CC62INA			CCU60 input
	CC62INB			CCU61 input
	SDA0A			I2C0 input
	CIFD4			CIF input
	P02.4			O0
	TOUT4	O1		GTM output
	ASCLK2	O2		ASCLIN2 output
	SLSO30	O3		QSPI3 output
	PSISCLK	O4		PSI5-S output
	SDA0	O5		I2C0 output
	TXENA	O6		ERAY output
	CC62	O7		CCU60 output
6	P02.5	I	MP+ / PU1 / VEXT	General-purpose input
	TIN5			GTM input
	MRST3A			QSPI3 input
	ECTT2			TTCAN input
	PSIRX1B			PSI5 input
	PSISRXB			PSI5-S input
	SENT3C			SENT input
	SCL0A			I2C0 input
	CIFD5			CIF input
	P02.5			O0
	TOUT5	O1		GTM output
	TXDCAN0	O2		CAN node 0 output
	MRST3	O3		QSPI3 output
	–	O4		Reserved
	SCL0	O5		I2C0 output
	TXENB	O6		ERAY output
	COU62	O7		CCU60 output

Package and Pinning Definitions TC265x Pin Definition and Functions:

Table 2-20 Port 02 Functions (cont'd)

Pin	Symbol	Ctrl	Type	Function		
7	P02.6	I	MP / PU1 / VEXT	General-purpose input		
	TIN6			GTM input		
	MTSR3A			QSPI3 input		
	SENT2C			SENT input		
	CC60INC			CCU60 input		
	CCPOS0A			CCU60 input		
	T12HRB			CCU61 input		
	T3INA			GPT120 input		
	CIFD6			CIF input		
	P02.6	O0		General-purpose output		
	TOUT6	O1		GTM output		
	PSISTX	O2		PSI5-S output		
	MTSR3	O3		QSPI3 output		
	PSITX1	O4		PSI5 output		
	VADCEMUX00	O5		VADC output		
	–	O6		Reserved		
	CC60	O7		CCU60 output		
	8	P02.7		I	MP / PU1 / VEXT	General-purpose input
		TIN7				GTM input
SCLK3A		QSPI3 input				
PSIRX2B		PSI5 input				
SENT1C		SENT input				
CC61INC		CCU60 input				
CCPOS1A		CCU60 input				
T13HRB		CCU61 input				
T3EUDA		GPT120 input				
CIFD7		CIF input				
DSCIN3B		DSADC channel 3 input B				
P02.7		O0	General-purpose output			
TOUT7		O1	GTM output			
–		O2	Reserved			
SCLK3		O3	QSPI3 output			
DSCOUT3		O4	DSADC channel 3 output			
VADCEMUX01		O5	VADC output			
SPC1		O6	SENT output			
CC61		O7	CCU60 output			

Package and Pinning Definitions TC265x Pin Definition and Functions:

Table 2-20 Port 02 Functions (cont'd)

Pin	Symbol	Ctrl	Type	Function
9	P02.8	I	LP / PU1 / VEXT	General-purpose input
	TIN8			GTM input
	SENT0C			SENT input
	CC62INC			CCU60 input
	CCPOS2A			CCU60 input
	T12HRC			CCU61 input
	T13HRC			CCU61 input
	T4INA			GPT120 input
	CIFD8			CIF input
	DSDIN3B			DSADC channel 3 input B
	DSITR3E			DSADC channel 3 input E
	P02.8			O0
	TOUT8	O1	GTM output	
	SLSO35	O2	QSPI3 output	
	–	O3	Reserved	
	PSITX2	O4	PSI5 output	
	VADCEMUX02	O5	VADC output	
	ETHMDC	O6	ETH output	
	CC62	O7	CCU60 output	

Table 2-21 Port 10 Functions

Pin	Symbol	Ctrl	Type	Function
168	P10.0	I	LP / PU1 / VEXT	General-purpose input
	TIN102			GTM input
	T6EUDB			GPT120 input
	P10.0	O0		General-purpose output
	TOUT102	O1		GTM output
	–	O2		Reserved
	SLSO110	O3		QSPI1 output
	–	O4		Reserved
	VADCG3BFL0	O5		VADC output
	–	O6		Reserved
	–	O7		Reserved

Package and Pinning Definitions TC265x Pin Definition and Functions:

Table 2-21 Port 10 Functions (cont'd)

Pin	Symbol	Ctrl	Type	Function
169	P10.1	I	MP+ / PU1 / VEXT	General-purpose input
	TIN103			GTM input
	MRST1A			QSPI1 input
	T5EUDB			GPT120 input
	P10.1	O0		General-purpose output
	TOUT103	O1		GTM output
	MTSR1	O2		QSPI1 output
	MRST1	O3		QSPI1 output
	EN01	O4		MSC0 output
	VADCG3BFL1	O5		VADC output
	END03	O6		MSC0 output
	–	O7		Reserved
	170	P10.2		I
TIN104		GTM input		
SCLK1A		QSPI1 input		
T6INB		GPT120 input		
REQ2		SCU input		
RXDCAN2E		CAN node 2 input		
SDI01		MSC0 input		
P10.2		O0	General-purpose output	
TOUT104		O1	GTM output	
–		O2	Reserved	
SCLK1		O3	QSPI1 output	
EN00		O4	MSC0 output	
VADCG3BFL2		O5	VADC output	
END02		O6	MSC0 output	
–		O7	Reserved	

Package and Pinning Definitions TC265x Pin Definition and Functions:

Table 2-21 Port 10 Functions (cont'd)

Pin	Symbol	Ctrl	Type	Function
171	P10.3	I	MP / PU1 / VEXT	General-purpose input
	TIN105			GTM input
	MTSR1A			QSPI1 input
	REQ3			SCU input
	T5INB			GPT120 input
	P10.3	O0		General-purpose output
	TOUT105	O1		GTM output
	VADCG3BFL3	O2		VADC output
	MTSR1	O3		QSPI1 output
	EN00	O4		MSC0 output
	END02	O5		MSC0 output
	TXDCAN2	O6		CAN node 2 output
	–	O7		Reserved
	172	P10.4		I
TIN106		GTM input		
MTSR1C		QSPI1 input		
CCPOS0C		CCU60 input		
T3INB		GPT120 input		
P10.4		O0	General-purpose output	
TOUT106		O1	GTM output	
–		O2	Reserved	
SLSO18		O3	QSPI1 output	
MTSR1		O4	QSPI1 output	
EN00		O5	MSC0 output	
END02		O6	MSC0 output	
–		O7	Reserved	

Package and Pinning Definitions TC265x Pin Definition and Functions:

Table 2-21 Port 10 Functions (cont'd)

Pin	Symbol	Ctrl	Type	Function
173	P10.5	I	LP / PU1 / VEXT	General-purpose input
	TIN107			GTM input
	HWCFG4			SCU input
	RXDCAN4B			CAN node 4 input
	INJ01			MSC0 input
	P10.5	O0		General-purpose output
	TOUT107	O1		GTM output
	ATX2	O2		ASCLIN2 output
	SLSO38	O3		QSPI3 output
	SLSO19	O4		QSPI1 output
	T6OUT	O5		GPT120 output
	ASLSO2	O6		ASCLIN2 output
	–	O7		Reserved
	174	P10.6		I
TIN108		GTM input		
ARX2D		ASCLIN2 input		
MTSR3B		QSPI3 input		
HWCFG5		SCU input		
P10.6		O0	General-purpose output	
TOUT108		O1	GTM output	
ASCLK2		O2	ASCLIN2 output	
MTSR3		O3	QSPI3 output	
T3OUT		O4	GPT120 output	
TXDCAN4		O5	CAN node 4 output	
MRST1		O6	QSPI1 output	
VADCG3BFL0		O7	VADC output	

Package and Pinning Definitions TC265x Pin Definition and Functions:

Table 2-21 Port 10 Functions (cont'd)

Pin	Symbol	Ctrl	Type	Function
175	P10.7	I	LP / PU1 / VEXT	General-purpose input
	TIN109			GTM input
	ACTS2A			ASCLIN2 input
	MRST3B			QSPI3 input
	REQ4			SCU input
	CCPOS1C			CCU60 input
	T3EUDB			GPT120 input
	P10.7	O0		General-purpose output
	TOUT109	O1		GTM output
	–	O2		Reserved
	MRST3	O3		QSPI3 output
	VADCG3BFL1	O4		VADC output
	–	O5		Reserved
	–	O6		Reserved
	–	O7		Reserved
176	P10.8	I	LP / PU1 / VEXT	General-purpose input
	TIN110			GTM input
	SCLK3B			QSPI3 input
	REQ5			SCU input
	CCPOS2C			CCU60 input
	T4INB			GPT120 input
	P10.8			O0
	TOUT110	O1		GTM output
	ARTS2	O2		ASCLIN2 output
	SCLK3	O3		QSPI3 output
	–	O4		Reserved
	–	O5		Reserved
	–	O6		Reserved
	–	O7		Reserved

Package and Pinning Definitions TC265x Pin Definition and Functions:

Table 2-22 Port 11 Functions

Pin	Symbol	Ctrl	Type	Function
160	P11.2	I	MPR / PU1 / VFLEX	General-purpose input
	TIN95			GTM input
	P11.2	O0		General-purpose output
	TOUT95	O1		GTM output
	END03	O2		MSC0 output
	SLSO05	O3		QSPI0 output
	SLSO15	O4		QSPI1 output
	EN01	O5		MSC0 output
	ETHTXD1	O6		ETH output
	COUT63	O7		CCU60 output
161	P11.3	I	MPR / PU1 / VFLEX	General-purpose input
	TIN96			GTM input
	MRST1B			QSPI1 input
	SDI03			MSC0 input
	P11.3	O0		General-purpose output
	TOUT96	O1		GTM output
	–	O2		Reserved
	MRST1	O3		QSPI1 output
	TXDA	O4		ERAY output
	–	O5		Reserved
	ETHTXD0	O6		ETH output
	COUT62	O7		CCU60 output
162	P11.6	I	MPR / PU1 / VFLEX	General-purpose input
	TIN97			GTM input
	SCLK1B			QSPI1 input
	P11.6	O0		General-purpose output
	TOUT97	O1		GTM output
	TXENB	O2		ERAY output
	SCLK1	O3		QSPI1 output
	TXENA	O4		ERAY output
	FCLP0	O5		MSC0 output
	ETHTXEN	O6		ETH output
	COUT61	O7		CCU60 output

Package and Pinning Definitions TC265x Pin Definition and Functions:

Table 2-22 Port 11 Functions (cont'd)

Pin	Symbol	Ctrl	Type	Function
163	P11.9	I	MP+ / PU1 / VFLEX	General-purpose input
	TIN98			GTM input
	MTSR1B			QSPI1 input
	RXDA1			ERAY input
	ETHRXD1			ETH input
	P11.9	O0		General-purpose output
	TOUT98	O1		GTM output
	–	O2		Reserved
	MTSR1	O3		QSPI1 output
	–	O4		Reserved
	SOP0	O5		MSC0 output
	–	O6		Reserved
	COU60	O7		CCU60 output
	165	P11.10		I
TIN99		GTM input		
REQ12		SCU input		
ARX1E		ASCLIN1 input		
SLSI1A		QSPI1 input		
RXDCAN3D		CAN node 3 input		
RXDB1		ERAY input		
ETHRXD0		ETH input		
SDI00		MSC0 input		
P11.10		O0	General-purpose output	
TOUT99		O1	GTM output	
–		O2	Reserved	
SLSO03		O3	QSPI0 output	
SLSO13		O4	QSPI1 output	
–		O5	Reserved	
–		O6	Reserved	
CC62		O7	CCU60 output	

Package and Pinning Definitions TC265x Pin Definition and Functions:

Table 2-22 Port 11 Functions (cont'd)

Pin	Symbol	Ctrl	Type	Function
166	P11.11	I	MP+ / PU1 / VFLEX	General-purpose input
	TIN100			GTM input
	ETHCRSDVA			ETH input
	P11.11	O0		General-purpose output
	TOUT100	O1		GTM output
	END02	O2		MSC0 output
	SLSO04	O3		QSPI0 output
	SLSO14	O4		QSPI1 output
	EN00	O5		MSC0 output
	TXENB	O6		ERAY output
	CC61	O7		CCU60 output
167	P11.12	I	MPR / PU1 / VFLEX	General-purpose input
	TIN101			GTM input
	ETHREFCLK			ETH input
	ETHTXCLKB			ETH input (Not for productive purposes)
	ETHRXCLKA			ETH input (Not for productive purposes)
	P11.12	O0		General-purpose output
	TOUT101	O1		GTM output
	ATX1	O2		ASCLIN1 output
	GTMCLK2	O3		GTM output
	TXDB	O4		ERAY output
	TXDCAN3	O5		CAN node 3 output
	EXTCLK1	O6		SCU output
	CC60	O7		CCU60 output

Table 2-23 Port 13 Functions

Pin	Symbol	Ctrl	Type	Function
156	P13.0	I	LVDSM_N / PU1 / VEXT	General-purpose input
	TIN91			GTM input
	P13.0	O0		General-purpose output
	TOUT91	O1		GTM output
	END03	O2		MSC0 output
	SCLK2N	O3		QSPI2 output (LVDS)
	EN01	O4		MSC0 output
	FCLN0	O5		MSC0 output (LVDS)
	FCLND0	O6		MSC0 output (LVDS)
	TXDCAN4	O7		CAN node 4 output

Package and Pinning Definitions TC265x Pin Definition and Functions:

Table 2-23 Port 13 Functions (cont'd)

Pin	Symbol	Ctrl	Type	Function
157	P13.1	I	LVDSM_P / PU1 / VEXT	General-purpose input
	TIN92			GTM input
	SCL0B			I2C0 input
	RXDCAN4C			CAN node 4 input
	P13.1	O0		General-purpose output
	TOUT92	O1		GTM output
	–	O2		Reserved
	SCLK2P	O3		QSPI2 output (LVDS)
	–	O4		Reserved
	FCLP0	O5		MSC0 output (LVDS)
	SCL0	O6		I2C0 output
	–	O7		Reserved
	158	P13.2		I
TIN93		GTM input		
CAPINA		GPT120 input		
SDA0B		I2C0 input		
P13.2		O0	General-purpose output	
TOUT93		O1	GTM output	
–		O2	Reserved	
MTSR2N		O3	QSPI2 output (LVDS)	
FCLP0		O4	MSC0 output	
SON0		O5	MSC0 output (LVDS)	
SDA0		O6	I2C0 output	
SOND0		O7	MSC0 output (LVDS)	
159		P13.3	I	LVDSM_P / PU1 / VEXT
	TIN94	GTM input		
	P13.3	O0	General-purpose output	
	TOUT94	O1	GTM output	
	–	O2	Reserved	
	MTSR2P	O3	QSPI2 output (LVDS)	
	–	O4	Reserved	
	SOP0	O5	MSC0 output (LVDS)	
	–	O6	Reserved	
	–	O7	Reserved	

Package and Pinning Definitions TC265x Pin Definition and Functions:

Table 2-24 Port 14 Functions

Pin	Symbol	Ctrl	Type	Function
142	P14.0	I	MP+ / PU1 / VEXT	General-purpose input
	TIN80			GTM input
	P14.0	O0		General-purpose output
	TOUT80	O1		GTM output
	ATX0	O2		ASCLIN0 output Recommended as Boot loader pin.
	TXDA	O3		ERAY output
	TXDB	O4		ERAY output
	TXDCAN1	O5		CAN node 1 output Used for single pin DAP (SPD) function.
	ASCLK0	O6		ASCLIN0 output
	COU62	O7		CCU60 output
143	P14.1	I	MP / PU1 / VEXT	General-purpose input
	TIN81			GTM input
	REQ15			SCU input
	ARX0A			ASCLIN0 input
	RXDCAN1B			CAN node 1 input Used for single pin DAP (SPD) function.
	RXDA3			ERAY input
	RXDB3			ERAY input
	EVRWUPA			SCU input
	P14.1	O0		General-purpose output
	TOUT81	O1		GTM output
	ATX0	O2		ASCLIN0 output Recommended as Boot loader pin.
	–	O3		Reserved
	–	O4		Reserved
	–	O5		Reserved
	–	O6		Reserved
	COU63	O7		CCU60 output

Package and Pinning Definitions TC265x Pin Definition and Functions:

Table 2-24 Port 14 Functions (cont'd)

Pin	Symbol	Ctrl	Type	Function
144	P14.2	I	LP / PU1 / VEXT	General-purpose input
	TIN82			GTM input
	HWCFG2 EVR13			SCU input Latched at cold power on reset to decide EVR13 activation.
	P14.2	O0		General-purpose output
	TOUT82	O1		GTM output
	ATX2	O2		ASCLIN2 output
	SLSO21	O3		QSPI2 output
	–	O4		Reserved
	–	O5		Reserved
	ASCLK2	O6		ASCLIN2 output
–	O7	Reserved		
145	P14.3	I	LP / PU1 / VEXT	General-purpose input
	TIN83			GTM input
	ARX2A			ASCLIN2 input
	REQ10			SCU input
	HWCFG3_BMI			SCU input
	SDI02			MSC0 input
	P14.3	O0		General-purpose output
	TOUT83	O1		GTM output
	ATX2	O2		ASCLIN2 output
	SLSO23	O3		QSPI2 output
	ASLSO1	O4		ASCLIN1 output
	ASLSO3	O5		ASCLIN3 output
	–	O6		Reserved
	–	O7		Reserved

Package and Pinning Definitions TC265x Pin Definition and Functions:

Table 2-24 Port 14 Functions (cont'd)

Pin	Symbol	Ctrl	Type	Function
146	P14.4	I	LP / PU1 / VEXT	General-purpose input
	TIN84			GTM input
	HWCFG6			SCU input Latched at cold power on reset to decide default pad reset state (PU or HighZ).
	P14.4	O0		General-purpose output
	TOUT84	O1		GTM output
	–	O2		Reserved
	–	O3		Reserved
	–	O4		Reserved
	–	O5		Reserved
	–	O6		Reserved
–	O7	Reserved		
147	P14.5	I	MP+ / PU1 / VEXT	General-purpose input
	TIN85			GTM input
	HWCFG1 EVR33			SCU input Latched at cold power on reset to decide EVR33 activation.
	P14.5	O0		General-purpose output
	TOUT85	O1		GTM output
	–	O2		Reserved
	–	O3		Reserved
	–	O4		Reserved
	–	O5		Reserved
	TXDB	O6		ERAY output
–	O7	Reserved		
148	P14.6	I	MP+ / PU1 / VEXT	General-purpose input
	TIN86			GTM input
	HWCFG0 DCLDO			SCU input If EVR13 active, latched at cold power on reset to decide between LDO and SMPS mode.
	P14.6	O0		General-purpose output
	TOUT86	O1		GTM output
	–	O2		Reserved
	SLSO22	O3		QSPI2 output
	–	O4		Reserved
	–	O5		Reserved
	TXENB	O6		ERAY output
–	O7	Reserved		

Package and Pinning Definitions TC265x Pin Definition and Functions:

Table 2-24 Port 14 Functions (cont'd)

Pin	Symbol	Ctrl	Type	Function
149	P14.7	I	LP / PU1 / VEXT	General-purpose input
	TIN87			GTM input
	RXDB0			ERAY input
	P14.7	O0		General-purpose output
	TOUT87	O1		GTM output
	ARTS0	O2		ASCLIN0 output
	SLSO24	O3		QSPI2 output
	–	O4		Reserved
	–	O5		Reserved
	–	O6		Reserved
	–	O7		Reserved
150	P14.8	I	LP / PU1 / VEXT	General-purpose input
	TIN88			GTM input
	ARX1D			ASCLIN1 input
	RXDCAN2D			CAN node 2 input
	RXDA0			ERAY input
	P14.8	O0		General-purpose output
	TOUT88	O1		GTM output
	–	O2		Reserved
	–	O3		Reserved
	–	O4		Reserved
	–	O5		Reserved
	–	O6		Reserved
	–	O7		Reserved
151	P14.9	I	MP+ / PU1 / VEXT	General-purpose input
	TIN89			GTM input
	ACTS0A			ASCLIN0 input
	P14.9	O0		General-purpose output
	TOUT89	O1		GTM output
	END03	O2		MSC0 output
	EN01	O3		MSC0 output
	–	O4		Reserved
	TXENB	O5		ERAY output
	TXENA	O6		ERAY output
	–	O7		Reserved

Package and Pinning Definitions TC265x Pin Definition and Functions:

Table 2-24 Port 14 Functions (cont'd)

Pin	Symbol	Ctrl	Type	Function
152	P14.10	I	MP+ / PU1 / VEXT	General-purpose input
	TIN90			GTM input
	P14.10	O0		General-purpose output
	TOUT90	O1		GTM output
	END02	O2		MSC0 output
	EN00	O3		MSC0 output
	ATX1	O4		ASCLIN1 output
	TXDCAN2	O5		CAN node 2 output
	TXDA	O6		ERAY output
	–	O7		Reserved

Table 2-25 Port 15 Functions

Pin	Symbol	Ctrl	Type	Function
133	P15.0	I	LP / PU1 / VEXT	General-purpose input
	TIN71			GTM input
	P15.0	O0		General-purpose output
	TOUT71	O1		GTM output
	ATX1	O2		ASCLIN1 output
	SLSO013	O3		QSPI0 output
	–	O4		Reserved
	TXDCAN2	O5		CAN node 2 output
	ASCLK1	O6		ASCLIN1 output
	–	O7		Reserved
134	P15.1	I	LP / PU1 / VEXT	General-purpose input
	TIN72			GTM input
	REQ16			SCU input
	ARX1A			ASCLIN1 input
	RXDCAN2A			CAN node 2 input
	SLSI2B			QSPI2 input
	EVRWUPB			SCU input
	P15.1			O0
	TOUT72	O1		GTM output
	ATX1	O2		ASCLIN1 output
	SLSO25	O3		QSPI2 output
	–	O4		Reserved
	–	O5		Reserved
	–	O6		Reserved
	–	O7		Reserved

Package and Pinning Definitions TC265x Pin Definition and Functions:

Table 2-25 Port 15 Functions (cont'd)

Pin	Symbol	Ctrl	Type	Function
135	P15.2	I	MP / PU1 / VEXT	General-purpose input
	TIN73			GTM input
	SLSI2A			QSPI2 input
	MRST2E			QSPI2 input
	HSIC2INA			QSPI2 input
	P15.2	O0		General-purpose output
	TOUT73	O1		GTM output
	ATX0	O2		ASCLIN0 output
	SLSO20	O3		QSPI2 output
	–	O4		Reserved
	TXDCAN1	O5		CAN node 1 output
	ASCLK0	O6		ASCLIN0 output
	–	O7		Reserved
	136	P15.3		I
TIN74		GTM input		
ARX0B		ASCLIN0 input		
SCLK2A		QSPI2 input		
RXDCAN1A		CAN node 1 input		
HSIC2INB		QSPI2 input		
P15.3		O0	General-purpose output	
TOUT74		O1	GTM output	
ATX0		O2	ASCLIN0 output	
SCLK2		O3	QSPI2 output	
END03		O4	MSC0 output	
EN01		O5	MSC0 output	
–		O6	Reserved	
–		O7	Reserved	

Package and Pinning Definitions TC265x Pin Definition and Functions:

Table 2-25 Port 15 Functions (cont'd)

Pin	Symbol	Ctrl	Type	Function
137	P15.4	I	MP / PU1 / VEXT	General-purpose input
	TIN75			GTM input
	MRST2A			QSPI2 input
	REQ0			SCU input
	SCL0C			I2C0 input
	P15.4	O0		General-purpose output
	TOUT75	O1		GTM output
	ATX1	O2		ASCLIN1 output
	MRST2	O3		QSPI2 output
	–	O4		Reserved
	–	O5		Reserved
	SCL0	O6		I2C0 output
	CC62	O7		CCU60 output
138	P15.5	I	MP / PU1 / VEXT	General-purpose input
	TIN76			GTM input
	ARX1B			ASCLIN1 input
	MTSR2A			QSPI2 input
	SDA0C			I2C0 input
	REQ13	SCU input		
	P15.5	O0		General-purpose output
	TOUT76	O1		GTM output
	ATX1	O2		ASCLIN1 output
	MTSR2	O3		QSPI2 output
	END02	O4		MSC0 output
	EN00	O5		MSC0 output
	SDA0	O6		I2C0 output
CC61	O7	CCU60 output		
139	P15.6	I	MP / PU1 / VEXT	General-purpose input
	TIN77			GTM input
	MTSR2B			QSPI2 input
	P15.6	O0		General-purpose output
	TOUT77	O1		GTM output
	ATX3	O2		ASCLIN3 output
	MTSR2	O3		QSPI2 output
	–	O4		Reserved
	SCLK2	O5		QSPI2 output
	ASCLK3	O6		ASCLIN3 output
	CC60	O7		CCU60 output

Package and Pinning Definitions TC265x Pin Definition and Functions:

Table 2-25 Port 15 Functions (cont'd)

Pin	Symbol	Ctrl	Type	Function
140	P15.7	I	MP / PU1 / VEXT	General-purpose input
	TIN78			GTM input
	ARX3A			ASCLIN3 input
	MRST2B			QSPI2 input
	P15.7	O0		General-purpose output
	TOUT78	O1		GTM output
	ATX3	O2		ASCLIN3 output
	MRST2	O3		QSPI2 output
	–	O4		Reserved
	–	O5		Reserved
	–	O6		Reserved
	COUT60	O7		CCU60 output
	141	P15.8		I
TIN79		GTM input		
SCLK2B		QSPI2 input		
REQ1		SCU input		
P15.8		O0	General-purpose output	
TOUT79		O1	GTM output	
–		O2	Reserved	
SCLK2		O3	QSPI2 output	
–		O4	Reserved	
–		O5	Reserved	
ASCLK3		O6	ASCLIN3 output	
COUT61		O7	CCU60 output	

Package and Pinning Definitions TC265x Pin Definition and Functions:

Table 2-26 Port 20 Functions

Pin	Symbol	Ctrl	Type	Function
116	P20.0	I	MP / PU1 / VEXT	General-purpose input
	TIN59			GTM input
	RXDCAN3C			CAN node 3 input
	T6EUDA			GPT120 input
	REQ9			SCU input
	SYSCLK			HSCT input
	TGI0			OCDS input
	P20.0	O0		General-purpose output
	TOUT59	O1		GTM output
	ATX3	O2		ASCLIN3 output
	ASCLK3	O3		ASCLIN3 output
	–	O4		Reserved
	SYSCLK	O5		HSCT output
	–	O6		Reserved
	–	O7		Reserved
	TGO0	HWOUT		OCDS; ENx
	117	P20.1		I
TIN60		GTM input		
TGI1		OCDS input		
P20.1		O0	General-purpose output	
TOUT60		O1	GTM output	
–		O2	Reserved	
–		O3	Reserved	
–		O4	Reserved	
–		O5	Reserved	
–		O6	Reserved	
–		O7	Reserved	
TGO1		HWOUT	OCDS; ENx	

Package and Pinning Definitions TC265x Pin Definition and Functions:

Table 2-26 Port 20 Functions (cont'd)

Pin	Symbol	Ctrl	Type	Function
118	P20.2	I	LP / PU / VEXT	General-purpose input This pin is latched at power on reset release to enter test mode.
	TESTMODE			OCDS input
	P20.2	O0		Output function not available
	–	O1		Output function not available
	–	O2		Output function not available
	–	O3		Output function not available
	–	O4		Output function not available
	–	O5		Output function not available
	–	O6		Output function not available
	–	O7		Output function not available
119	P20.3	I	LP / PU1 / VEXT	General-purpose input
	TIN61			GTM input
	T6INA			GPT120 input
	ARX3C			ASCLIN3 input
	P20.3	O0		General-purpose output
	TOUT61	O1		GTM output
	ATX3	O2		ASCLIN3 output
	SLSO09	O3		QSPI0 output
	SLSO29	O4		QSPI2 output
	TXDCAN3	O5		CAN node 3 output
	–	O6		Reserved
	–	O7		Reserved
124	P20.6	I	LP / PU1 / VEXT	General-purpose input
	TIN62			GTM input
	P20.6	O0		General-purpose output
	TOUT62	O1		GTM output
	ARTS1	O2		ASCLIN1 output
	SLSO08	O3		QSPI0 output
	SLSO28	O4		QSPI2 output
	–	O5		Reserved
	–	O6		Reserved
	–	O7		Reserved

Package and Pinning Definitions TC265x Pin Definition and Functions:

Table 2-26 Port 20 Functions (cont'd)

Pin	Symbol	Ctrl	Type	Function
125	P20.7	I	LP / PU1 / VEXT	General-purpose input
	TIN63			GTM input
	ACTS1A			ASCLIN1 input
	RXDCAN0B			CAN node 0 input
	P20.7	O0		General-purpose output
	TOUT63	O1		GTM output
	–	O2		Reserved
	–	O3		Reserved
	–	O4		Reserved
	–	O5		Reserved
	WDT1LCK	O6		SCU output
	COU63	O7		CCU61 output
126	P20.8	I	MP / PU1 / VEXT	General-purpose input
	TIN64			GTM input
	P20.8	O0		General-purpose output
	TOUT64	O1		GTM output
	ASLSO1	O2		ASCLIN1 output
	SLSO00	O3		QSPI0 output
	SLSO10	O4		QSPI1 output
	TXDCAN0	O5		CAN node 0 output
	WDT0LCK	O6		SCU output
	CC60	O7		CCU61 output
127	P20.9	I	LP / PU1 / VEXT	General-purpose input
	TIN65			GTM input
	ARX1C			ASCLIN1 input
	RXDCAN3E			CAN node 3 input
	REQ11			SCU input
	SLSI0B			QSPI0 input
	P20.9			O0
	TOUT65	O1		GTM output
	–	O2		Reserved
	SLSO01	O3		QSPI0 output
	SLSO11	O4		QSPI1 output
	–	O5		Reserved
	WDTSLCK	O6		SCU output
	CC61	O7		CCU61 output

Package and Pinning Definitions TC265x Pin Definition and Functions:

Table 2-26 Port 20 Functions (cont'd)

Pin	Symbol	Ctrl	Type	Function
128	P20.10	I	MP / PU1 / VEXT	General-purpose input
	TIN66			GTM input
	P20.10			General-purpose output
	TOUT66	O1		GTM output
	ATX1	O2		ASCLIN1 output
	SLSO06	O3		QSPI0 output
	SLSO27	O4		QSPI2 output
	TXDCAN3	O5		CAN node 3 output
	ASCLK1	O6		ASCLIN1 output
	CC62	O7		CCU61 output
129	P20.11	I	MP / PU1 / VEXT	General-purpose input
	TIN67			GTM input
	SCLK0A			QSPI0 input
	P20.11	O0		General-purpose output
	TOUT67	O1		GTM output
	–	O2		Reserved
	SCLK0	O3		QSPI0 output
	–	O4		Reserved
	–	O5		Reserved
	–	O6		Reserved
	COU60	O7		CCU61 output
130	P20.12	I	MP / PU1 / VEXT	General-purpose input
	TIN68			GTM input
	MRST0A			QSPI0 input
	P20.12	O0		General-purpose output
	TOUT68	O1		GTM output
	–	O2		Reserved
	MRST0	O3		QSPI0 output
	MTSR0	O4		QSPI0 output
	–	O5		Reserved
	–	O6		Reserved
	COU61	O7		CCU61 output

Package and Pinning Definitions TC265x Pin Definition and Functions:

Table 2-26 Port 20 Functions (cont'd)

Pin	Symbol	Ctrl	Type	Function
131	P20.13	I	MP / PU1 / VEXT	General-purpose input
	TIN69			GTM input
	SLSIOA			QSPI0 input
	P20.13	O0		General-purpose output
	TOUT69	O1		GTM output
	–	O2		Reserved
	SLSO02	O3		QSPI0 output
	SLSO12	O4		QSPI1 output
	SCLK0	O5		QSPI0 output
	–	O6		Reserved
	COOUT62	O7		CCU61 output
132	P20.14	I	MP / PU1 / VEXT	General-purpose input
	TIN70			GTM input
	MTSR0A			QSPI0 input
	P20.14	O0		General-purpose output
	TOUT70	O1		GTM output
	–	O2		Reserved
	MTSR0	O3		QSPI0 output
	–	O4		Reserved
	–	O5		Reserved
	–	O6		Reserved
	–	O7		Reserved

Table 2-27 Port 21 Functions

Pin	Symbol	Ctrl	Type	Function
105	P21.0	I	A2 / PU1 / VDDP3	General-purpose input
	TIN51			GTM input
	P21.0	O0		General-purpose output
	TOUT51	O1		GTM output
	–	O2		Reserved
	–	O3		Reserved
	–	O4		Reserved
	–	O5		Reserved
	ETHMDC	O6		ETH output
	–	O7		Reserved

Package and Pinning Definitions TC265x Pin Definition and Functions:

Table 2-27 Port 21 Functions (cont'd)

Pin	Symbol	Ctrl	Type	Function
106	P21.1	I	A2 / PU1 / VDDP3	General-purpose input
	TIN52			GTM input
	ETHMDIOB			ETH input (Not for production purposes)
	P21.1	O0		General-purpose output
	TOUT52	O1		GTM output
	–	O2		Reserved
	–	O3		Reserved
	–	O4		Reserved
	–	O5		Reserved
	ETHMDIO	O6		ETH output (Not for production purposes)
–	O7	Reserved		
107	P21.2	I	LVDSH_N/ PU1 / VDDP3	General-purpose input
	TIN53			GTM input
	MRST2CN			QSPI2 input (LVDS)
	MRST3FN			QSPI3 input (LVDS)
	EMGSTOPB			SCU input
	RXDN			HSCT input (LVDS)
	P21.2	O0		General-purpose output
	TOUT53	O1		GTM output
	ASLSO3	O2		ASCLIN3 output
	–	O3		Reserved
	–	O4		Reserved
	ETHMDC	O5		ETH output
	–	O6		Reserved
	–	O7		Reserved

Package and Pinning Definitions TC265x Pin Definition and Functions:

Table 2-27 Port 21 Functions (cont'd)

Pin	Symbol	Ctrl	Type	Function
108	P21.3	I	LVDSH_P/ PU1 / VDDP3	General-purpose input
	TIN54			GTM input
	MRST2CP			QSPI2 input (LVDS)
	MRST3FP			QSPI3 input (LVDS)
	RXDP			HSCT input (LVDS)
	P21.3	O0		General-purpose output
	TOUT54	O1		GTM output
	–	O2		Reserved
	–	O3		Reserved
	–	O4		Reserved
	–	O5		Reserved
	–	O6		Reserved
	–	O7		Reserved
	ETHMDIOD	HWOUT		ETH input/output
109	P21.4	I	LVDSH_N/ PU1 / VDDP3	General-purpose input
	TIN55			GTM input
	P21.4	O0		General-purpose output
	TOUT55	O1		GTM output
	–	O2		Reserved
	–	O3		Reserved
	–	O4		Reserved
	–	O5		Reserved
	–	O6		Reserved
	–	O7		Reserved
	TXDN	O		HSCT output (LVDS)
	110	P21.5		I
TIN56		GTM input		
P21.5		O0	General-purpose output	
TOUT56		O1	GTM output	
ASCLK3		O2	ASCLIN3 output	
–		O3	Reserved	
–		O4	Reserved	
–		O5	Reserved	
–		O6	Reserved	
–		O7	Reserved	
TXDP		O	HSCT output (LVDS)	

Package and Pinning Definitions TC265x Pin Definition and Functions:

Table 2-27 Port 21 Functions (cont'd)

Pin	Symbol	Ctrl	Type	Function
111 ¹⁾	P21.6	I	A2 / PU / VDDP3	General-purpose input
	TIN57			GTM input
	ARX3F			ASCLIN3 input
	TGI2			OCDS input
	TDI			OCDS (JTAG) input
	T5EUDA			GPT120 input
	P21.6			O0
	TOUT57	O1		GTM output
	ASLSO3	O2		ASCLIN3 output
	–	O3		Reserved
	–	O4		Reserved
	SYSCLK	O5		HSCT output
	–	O6		Reserved
	T3OUT	O7		GPT120 output
	TGO2	HWOUT		OCDS; ENx
	T			

Package and Pinning Definitions TC265x Pin Definition and Functions:

Table 2-27 Port 21 Functions (cont'd)

Pin	Symbol	Ctrl	Type	Function
113	P21.7	I	A2 / PU / VDDP3	General-purpose input
	TIN58			GTM input
	DAP2			OCDS (3-Pin DAP) input In the 3-Pin DAP mode this pin is used as DAP2. In the 2-PIN DAP mode this pin is used as P21.7 and controlled by the related port control logic.
	TGI3			OCDS input
	ETHRXERB			ETH input
	T5INA			GPT120 input
	P21.7			O0
	TOUT58	O1		GTM output
	ATX3	O2		ASCLIN3 output
	ASCLK3	O3		ASCLIN3 output
	–	O4		Reserved
	–	O5		Reserved
	–	O6		Reserved
	T6OUT	O7		GPT120 output
	TGO3	HWOU T		OCDS; ENx
	TDO			OCDS (JTAG); ENx The JTAG TDO function is overlaid with P21.7 via a double bond. In JTAG mode this pin is used as TDO, after power-on reset it is HighZ.
	DAP2			OCDS (DAP2); ENx In the 3-Pin DAP mode this pin is used as DAP2.

1) For an Emulation Device in a non Fusion Quad package this pin is used as VDDPSB (3.3V)

Table 2-28 Port 22 Functions

Pin	Symbol	Ctrl	Type	Function
95	P22.0	I	LVDSM_N / PU1 / VEXT	General-purpose input
	TIN47			GTM input
	MTSR3E			QSPI3 input
	P22.0	O0		General-purpose output
	TOUT47	O1		GTM output
	–	O2		Reserved
	MTSR3	O3		QSPI3 output
	SCLK3N	O4		QSPI3 output (LVDS)
	FCLN1	O5		MSC1 output (LVDS)
	FCLND1	O6		MSC1 output (LVDS)
	–	O7		Reserved

Package and Pinning Definitions TC265x Pin Definition and Functions:

Table 2-28 Port 22 Functions (cont'd)

Pin	Symbol	Ctrl	Type	Function
96	P22.1	I	LVDSM_P / PU1 / VEXT	General-purpose input
	TIN48			GTM input
	MRST3E			QSPI3 input
	P22.1	O0		General-purpose output
	TOUT48	O1		GTM output
	–	O2		Reserved
	MRST3	O3		QSPI3 output
	SCLK3P	O4		QSPI3 output (LVDS)
	FCLP1	O5		MSC1 output (LVDS)
	–	O6		Reserved
	–	O7		Reserved
97	P22.2	I	LVDSM_N / PU1 / VEXT	General-purpose input
	TIN49			GTM input
	SLSI3D			QSPI3 input
	P22.2	O0		General-purpose output
	TOUT49	O1		GTM output
	–	O2		Reserved
	SLSO312	O3		QSPI3 output
	MTR3N	O4		QSPI3 output (LVDS)
	SON1	O5		MSC1 output (LVDS)
	SOND1	O6		MSC1 output (LVDS)
	–	O7		Reserved
98	P22.3	I	LVDSM_P / PU1 / VEXT	General-purpose input
	TIN50			GTM input
	SCLK3E			QSPI3 input
	P22.3	O0		General-purpose output
	TOUT50	O1		GTM output
	–	O2		Reserved
	SCLK3	O3		QSPI3 output
	MTR3P	O4		QSPI3 output (LVDS)
	SOP1	O5		MSC1 output (LVDS)
	–	O6		Reserved
	–	O7		Reserved

Package and Pinning Definitions TC265x Pin Definition and Functions:

Table 2-29 Port 23 Functions

Pin	Symbol	Ctrl	Type	Function
89	P23.0	I	LP / PU1 / VEXT	General-purpose input
	TIN41			GTM input
	P23.0	O0		General-purpose output
	TOUT41	O1		GTM output
	–	O2		Reserved
	–	O3		Reserved
	–	O4		Reserved
	–	O5		Reserved
	–	O6		Reserved
	–	O7		Reserved
90	P23.1	I	MP+ / PU1 / VEXT	General-purpose input
	TIN42			GTM input
	SDI10			MSC1 input
	P23.1	O0		General-purpose output
	TOUT42	O1		GTM output
	ARTS1	O2		ASCLIN1 output
	SLSO313	O3		QSPI3 output
	GTMCLK0	O4		GTM output
	–	O5		Reserved
	EXTCLK0	O6		SCU output
	–	O7		Reserved
91	P23.2	I	LP / PU1 / VEXT	General-purpose input
	TIN43			GTM input
	P23.2	O0		General-purpose output
	TOUT43	O1		GTM output
	–	O2		Reserved
	–	O3		Reserved
	–	O4		Reserved
	–	O5		Reserved
	–	O6		Reserved
	–	O7		Reserved

Package and Pinning Definitions TC265x Pin Definition and Functions:

Table 2-29 Port 23 Functions (cont'd)

Pin	Symbol	Ctrl	Type	Function
92	P23.3	I	LP / PU1 / VEXT	General-purpose input
	TIN44			GTM input
	INJ10			MSC1 input
	P23.3	O0		General-purpose output
	TOUT44	O1		GTM output
	–	O2		Reserved
	–	O3		Reserved
	–	O4		Reserved
	–	O5		Reserved
	–	O6		Reserved
	–	O7		Reserved
93	P23.4	I	MP+ / PU1 / VEXT	General-purpose input
	TIN45			GTM input
	P23.4			O0
	TOUT45	O1		GTM output
	–	O2		Reserved
	SLSO35	O3		QSPI3 output
	END12	O4		MSC1 output
	EN10	O5		MSC1 output
	–	O6		Reserved
	–	O7		Reserved
	94	P23.5		I
TIN46		GTM input		
P23.5		O0	General-purpose output	
TOUT46		O1	GTM output	
–		O2	Reserved	
SLSO34		O3	QSPI3 output	
END13		O4	MSC1 output	
EN11		O5	MSC1 output	
–		O6	Reserved	
–		O7	Reserved	

Package and Pinning Definitions TC265x Pin Definition and Functions:

Table 2-30 Port 32 Functions

Pin	Symbol	Ctrl	Type	Function
84	P32.0	I	LP / PX/ VEXT	General-purpose input
	TIN36			GTM input
	FDEST			PMU input
	VGATE1N			SMPS mode: analog output. External Pass Device gate control for EVR13
	P32.0	O0		General-purpose output
	TOUT36	O1		GTM output
	–	O2		Reserved
	–	O3		Reserved
	–	O4		Reserved
	–	O5		Reserved
	–	O6		Reserved
	–	O7		Reserved
86	P32.2	I	LP / PU1 / VEXT	General-purpose input
	TIN38			GTM input
	ARX3D			ASCLIN3 input
	RXDCAN3B			CAN node 3 input
	P32.2	O0		General-purpose output
	TOUT38	O1		GTM output
	ATX3	O2		ASCLIN3 output
	–	O3		Reserved
	–	O4		Reserved
	–	O5		Reserved
	DCDCSYNC	O6		SCU output
	–	O7		Reserved
87	P32.3	I	LP / PU1 / VEXT	General-purpose input
	TIN39			GTM input
	P32.3	O0		General-purpose output
	TOUT39	O1		GTM output
	ATX3	O2		ASCLIN3 output
	–	O3		Reserved
	ASCLK3	O4		ASCLIN3 output
	TXDCAN3	O5		CAN node 3 output
	–	O6		Reserved
	–	O7		Reserved

Package and Pinning Definitions TC265x Pin Definition and Functions:

Table 2-30 Port 32 Functions (cont'd)

Pin	Symbol	Ctrl	Type	Function
88	P32.4	I	MP+ / PU1 / VEXT	General-purpose input
	TIN40			GTM input
	ACTS1B			ASCLIN1 input
	SDI12			MSC1 input
	P32.4	O0		General-purpose output
	TOUT40	O1		GTM output
	–	O2		Reserved
	END12	O3		MSC1 output
	GTMCLK1	O4		GTM output
	EN10	O5		MSC1 output
	EXTCLK1	O6		SCU output
	COU63	O7		CCU60 output

Table 2-31 Port 33 Functions

Pin	Symbol	Ctrl	Type	Function
70	P33.0	I	LP / PU1 / VEXT	General-purpose input
	TIN22			GTM input
	DSITR0E			DSADC channel 0 input E
	P33.0	O0		General-purpose output
	TOUT22	O1		GTM output
	–	O2		Reserved
	–	O3		Reserved
	–	O4		Reserved
	–	O5		Reserved
	VADCG1BFL0	O6		VADC output
	–	O7		Reserved
71	P33.1	I	LP / PU1 / VEXT	General-purpose input
	TIN23			GTM input
	PSIRX0C			PSI5 input
	DSCIN2B			DSADC channel 2 input B
	P33.1	O0		General-purpose output
	TOUT23	O1		GTM output
	ASLSO3	O2		ASCLIN3 output
	–	O3		Reserved
	DSCOUT2	O4		DSADC channel 2 output
	VADCEMUX02	O5		VADC output
	VADCG1BFL1	O6		VADC output
	–	O7		Reserved

Package and Pinning Definitions TC265x Pin Definition and Functions:

Table 2-31 Port 33 Functions (cont'd)

Pin	Symbol	Ctrl	Type	Function
72	P33.2	I	LP / PU1 / VEXT	General-purpose input
	TIN24			GTM input
	DSDIN2B			DSADC channel 2 input B
	DSITR2E			DSADC channel 2 input E
	P33.2	O0		General-purpose output
	TOUT24	O1		GTM output
	ASCLK3	O2		ASCLIN3 output
	–	O3		Reserved
	PSITX0	O4		PSI5 output
	VADCEMUX01	O5		VADC output
	VADCG1BFL2	O6		VADC output
	–	O7		Reserved
73	P33.3	I	LP / PU1 / VEXT	General-purpose input
	TIN25			GTM input
	PSIRX1C			PSI5 input
	P33.3	O0		General-purpose output
	TOUT25	O1		GTM output
	–	O2		Reserved
	–	O3		Reserved
	–	O4		Reserved
	VADCEMUX00	O5		VADC output
	VADCG1BFL3	O6		VADC output
	–	O7		Reserved
	74	P33.4		I
TIN26		GTM input		
CTRAPC		CCU61 input		
DSITR0F		DSADC channel 0 input F		
P33.4		O0	General-purpose output	
TOUT26		O1	GTM output	
ARTS2		O2	ASCLIN2 output	
–		O3	Reserved	
PSITX1		O4	PSI5 output	
VADCEMUX12		O5	VADC output	
VADCG0BFL0		O6	VADC output	
–		O7	Reserved	

Package and Pinning Definitions TC265x Pin Definition and Functions:

Table 2-31 Port 33 Functions (cont'd)

Pin	Symbol	Ctrl	Type	Function
75	P33.5	I	LP / PU1 / VEXT	General-purpose input
	TIN27			GTM input
	ACTS2B			ASCLIN2 input
	PSIRX2C			PSI5 input
	PSISRXC			PSI5-S input
	SENT5C			SENT input
	CCPOS2C			CCU61 input
	T4EUDB			GPT120 input
	DSCIN0B			DSADC channel 0 input B
	P33.5			O0
	TOUT27	O1		GTM output
	SLSO07	O2		QSPI0 output
	SLSO17	O3		QSPI1 output
	DSCOUT0	O4		DSADC channel 0 output
	VADCEMUX11	O5		VADC output
	VADCG0BFL1	O6		VADC output
	–	O7		Reserved
	76	P33.6		I
TIN28		GTM input		
SENT4C		SENT input		
CCPOS1C		CCU61 input		
T2EUDB		GPT120 input		
DSDIN0B		DSADC channel 0 input B		
DSITR2F		DSADC channel 2 input F		
P33.6		O0	General-purpose output	
TOUT28		O1	GTM output	
ASLSO2		O2	ASCLIN2 output	
–		O3	Reserved	
PSITX2		O4	PSI5 output	
VADCEMUX10		O5	VADC output	
VADCG0BFL2		O6	VADC output	
PSISTX		O7	PSI5-S output	

Package and Pinning Definitions TC265x Pin Definition and Functions:

Table 2-31 Port 33 Functions (cont'd)

Pin	Symbol	Ctrl	Type	Function
77	P33.7	I	LP / PU1 / VEXT	General-purpose input
	TIN29			GTM input
	RXDCAN0E			CAN node 0 input
	REQ8			SCU input
	CCPOS0C			CCU61 input
	T2INB			GPT120 input
	P33.7			O0
	TOUT29	O1		GTM output
	ASCLK2	O2		ASCLIN2 output
	SLSO37	O3		QSPI3 output
	–	O4		Reserved
	–	O5		Reserved
	VADCG0BFL3	O6		VADC output
	–	O7		Reserved
78	P33.8	I	MP / HighZ/ VEXT	General-purpose input
	TIN30			GTM input
	ARX2E			ASCLIN2 input
	EMGSTOPA			SCU input
	P33.8	O0		General-purpose output
	TOUT30	O1		GTM output
	ATX2	O2		ASCLIN2 output
	SLSO32	O3		QSPI3 output
	–	O4		Reserved
	TXDCAN0	O5		CAN node 0 output
	–	O6		Reserved
	COU62	O7		CCU61 output
	SMUFSP	HWOUT		SMU
79	P33.9	I	LP / PU1 / VEXT	General-purpose input
	TIN31			GTM input
	HSIC3INA			QSPI3 input
	P33.9	O0		General-purpose output
	TOUT31	O1		GTM output
	ATX2	O2		ASCLIN2 output
	SLSO31	O3		QSPI3 output
	ASCLK2	O4		ASCLIN2 output
	–	O5		Reserved
	–	O6		Reserved
	CC62	O7		CCU61 output

Package and Pinning Definitions TC265x Pin Definition and Functions:

Table 2-31 Port 33 Functions (cont'd)

Pin	Symbol	Ctrl	Type	Function
80	P33.10	I	MP / PU1 / VEXT	General-purpose input
	TIN32			GTM input
	SLSI3C			QSPI3 input
	HSIC3INB			QSPI3 input
	P33.10	O0		General-purpose output
	TOUT32	O1		GTM output
	SLSO16	O2		QSPI1 output
	SLSO311	O3		QSPI3 output
	ASLSO1	O4		ASCLIN1 output
	PSISCLK	O5		PSI5-S output
	–	O6		Reserved
	COUT61	O7		CCU61 output
81	P33.11	I	MP / PU1 / VEXT	General-purpose input
	TIN33			GTM input
	SCLK3D			QSPI3 input
	P33.11			O0
	TOUT33	O1		GTM output
	ASCLK1	O2		ASCLIN1 output
	SCLK3	O3		QSPI3 output
	–	O4		Reserved
	–	O5		Reserved
	DSCGPWMN	O6		DSADC output
	CC61	O7		CCU61 output
	82	P33.12		I
TIN34		GTM input		
MTR3D		QSPI3 input		
P33.12		O0	General-purpose output	
TOUT34		O1	GTM output	
ATX1		O2	ASCLIN1 output	
MTR3		O3	QSPI3 output	
ASCLK1		O4	ASCLIN1 output	
–		O5	Reserved	
DSCGPWMP		O6	DSADC output	
COUT60		O7	CCU61 output	

Package and Pinning Definitions TC265x Pin Definition and Functions:

Table 2-31 Port 33 Functions (cont'd)

Pin	Symbol	Ctrl	Type	Function
83	P33.13	I	MP / PU1 / VEXT	General-purpose input
	TIN35			GTM input
	ARX1F			ASCLIN1 input
	MRST3D			QSPI3 input
	DSSGNB			DSADC input
	INJ11			MSC1 input
	P33.13			O0
	TOUT35	O1		GTM output
	ATX1	O2		ASCLIN1 output
	MRST3	O3		QSPI3 output
	SLSO26	O4		QSPI2 output
	–	O5		Reserved
	DCDCSYNC	O6		SCU output
	CC60	O7		CCU61 output

Table 2-32 Port 40 Functions

Pin	Symbol	Ctrl	Type	Function
44	P40.0	I	S / HighZ / VDDM	General-purpose input
	VADCG1.8			VADC analog input channel 8 of group 1
	CCPOS0D			CCU60 input
	SENT0A			SENT input
43	P40.1	I	S / HighZ / VDDM	General-purpose input
	VADCG1.9			VADC analog input channel 9 of group 1 (MD)
	CCPOS1B			CCU60 input
	SENT1A			SENT input
42	P40.2	I	S / HighZ / VDDM	General-purpose input
	VADCG1.10			VADC analog input channel 10 of group 1 (MD)
	CCPOS1D			CCU60 input
	SENT2A			SENT input
41	P40.3	I	S / HighZ / VDDM	General-purpose input
	VADCG1.11			VADC analog input channel 11 of group 1
	CCPOS2B			CCU60 input
	SENT3A			SENT input
35	P40.6	I	S / HighZ / VDDM	General-purpose input
	VADCG2.4			VADC analog input channel 4 of group 2
	DS3PA			DSADC: positive analog input of channel 3, pin A
	CCPOS1B			CCU61 input
	SENT2D			SENT input

Package and Pinning Definitions TC265x Pin Definition and Functions:

Table 2-32 Port 40 Functions (cont'd)

Pin	Symbol	Ctrl	Type	Function
34	P40.7	I	S / HighZ / VDDM	General-purpose input
	VADCG2.5			VADC analog input channel 5 of group 2
	DS3NA			DSADC: negative analog input channel of DSADC 3, pin A
	CCPOS1D			CCU61 input
	SENT3D			SENT input
33	P40.8	I	S / HighZ / VDDM	General-purpose input
	VADCG2.6			VADC analog input channel 6 of group 2
	DS3PB			DSADC: positive analog input of channel 3, pin B
	CCPOS2B			CCU61 input
	SENT4A			SENT input
32	P40.9	I	S / HighZ / VDDM	General-purpose input
	VADCG2.7			VADC analog input channel 7 of group 2
	DS3NB			DSADC: negative analog input channel of DSADC 3, pin B
	CCPOS2D			CCU61 input
	SENT5A			SENT input

Table 2-33 Analog Inputs

Pin	Symbol	Ctrl	Type	Function
67	AN0	I	D / HighZ / VDDM	Analog input 0
	VADCG0.0			VADC analog input channel 0 of group 0
	DS0PB			DSADC: positive analog input of channel 0, pin B
66	AN1	I	D / HighZ / VDDM	Analog input 1
	VADCG0.1			VADC analog input channel 1 of group 0 (MD)
	DS0NB			DSADC: negative analog input channel of DSADC 0, pin B
65	AN2	I	D / HighZ / VDDM	Analog input 2
	VADCG0.2			VADC analog input channel 2 of group 0 (MD)
	DS0PA			DSADC: positive analog input of channel 0, pin A
64	AN3	I	D / HighZ / VDDM	Analog input 3
	VADCG0.3			VADC analog input channel 3 of group 0
	DS0NA			DSADC: negative analog input channel of DSADC 0, pin A
63	AN4	I	D / HighZ / VDDM	Analog input 4
	VADCG0.4			VADC analog input channel 4 of group 0
62	AN5	I	D / HighZ / VDDM	Analog input 5
	VADCG0.5			VADC analog input channel 5 of group 0

Package and Pinning Definitions TC265x Pin Definition and Functions:

Table 2-33 Analog Inputs (cont'd)

Pin	Symbol	Ctrl	Type	Function
61	AN6	I	D / HighZ / VDDM	Analog input 6
	VADCG0.6			VADC analog input channel 6 of group 0
60	AN7	I	D / HighZ / VDDM	Analog input 7
	VADCG0.7			VADC analog input channel 7 of group 0 (with pull down diagnostics)
59	AN8	I	D / HighZ / VDDM	Analog input 8
	VADCG0.8			VADC analog input channel 8 of group 0
58	AN10	I	D / HighZ / VDDM	Analog input 10
	VADCG0.10			VADC analog input channel 10 of group 0 (MD)
57	AN11	I	D / HighZ / VDDM	Analog input 11
	VADCG0.11			VADC analog input channel 11 of group 0
56	AN12	I	D / HighZ / VDDM	Analog input 12
	VADCG0.12			VADC analog input channel 12 of group 0
55	AN13	I	D / HighZ / VDDM	Analog input 13
	VADCG0.13			VADC analog input channel 13 of group 0
50	AN16	I	D / HighZ / VDDM	Analog input 16
	VADCG1.0			VADC analog input channel 0 of group 1
49	AN17	I	D / HighZ / VDDM	Analog input 17
	VADCG1.1			VADC analog input channel 1 of group 1 (MD)
48	AN18	I	D / HighZ / VDDM	Analog input 18
	VADCG1.2			VADC analog input channel 2 of group 1 (MD)
47	AN19	I	D / HighZ / VDDM	Analog input 19
	VADCG1.3			VADC analog input channel 3 of group 1 (with pull down diagnostics)
46	AN20	I	D / HighZ / VDDM	Analog input 20
	VADCG1.4			VADC analog input channel 4 of group 1
	DS2PA			DSADC: positive analog input of channel 2, pin A
45	AN21	I	D / HighZ / VDDM	Analog input 21
	VADCG1.5			VADC analog input channel 5 of group 1
	DS2NA			DSADC: negative analog input channel of DSADC 2, pin A
44	AN24	I	S / HighZ / VDDM	Analog input 24
	VADCG1.8			VADC analog input channel 8 of group 1
	SENT0A			SENT input channel 0, pin A

Package and Pinning Definitions TC265x Pin Definition and Functions:

Table 2-33 Analog Inputs (cont'd)

Pin	Symbol	Ctrl	Type	Function
43	AN25	I	S / HighZ / VDDM	Analog input 24
	VADCG1.9			VADC analog input channel 9 of group 1 (MD)
	SENT1A			SENT input channel 1, pin A
42	AN26	I	S / HighZ / VDDM	Analog input 26
	VADCG1.10			VADC analog input channel 10 of group 1 (MD)
	SENT2A			SENT input channel 2, pin A
41	AN27	I	S / HighZ / VDDM	Analog input 27
	VADCG1.11			VADC analog input channel 11 of group 1
	SENT3A			SENT input channel 3, pin A
40	AN28	I	D / HighZ / VDDM	Analog input 28
	VADCG1.12			VADC analog input channel 12 of group 1
39	AN29	I	D / HighZ / VDDM	Analog input 29
	VADCG1.13			VADC analog input channel 13 of group 1
38	AN32	I	D / HighZ / VDDM	Analog input 32
	VADCG2.0			VADC analog input channel 0 of group 2
37	AN33	I	D / HighZ / VDDM	Analog input 33
	VADCG2.1			VADC analog input channel 1 of group 2 (MD)
36	AN35	I	D / HighZ / VDDM	Analog input 35
	VADCG2.3			VADC analog input channel 3 of group 2 (with pull down diagnostics)
35	AN36	I	S / HighZ / VDDM	Analog input 34
	VADCG2.4			VADC analog input channel 4 of group 2
	DS3PA			DSADC: positive analog input of channel 3, pin A
	SENT2D			SENT input channel 2, pin D
34	AN37	I	S / HighZ / VDDM	Analog input 37
	VADCG2.5			VADC analog input channel 5 of group 2
	DS3NA			DSADC: negative analog input channel of DSADC 3, pin A
	SENT3D			SENT input channel 3, pin D
33	AN38	I	S / HighZ / VDDM	Analog input 38
	VADCG2.6			VADC analog input channel 6 of group 2
	DS3PB			DSADC: positive analog input of channel 3, pin B
	SENT4A			SENT input channel 4, pin A

Package and Pinning Definitions TC265x Pin Definition and Functions:

Table 2-33 Analog Inputs (cont'd)

Pin	Symbol	Ctrl	Type	Function
32	AN39	I	S / HighZ / VDDM	Analog input 39
	VADCG2.7			VADC analog input channel 7 of group 2
	DS3NB			DSADC: negative analog input channel of DSADC 3, pin B
	SENT5A			SENT input channel 5, pin A
31	AN44	I	D / HighZ / VDDM	Analog input 44
	VADCG2.10			VADC analog input channel 10 of group 2 (MD)
	DS3PC			DSADC: positive analog input of channel 3, pin C
30	AN45	I	D / HighZ / VDDM	Analog input 45
	VADCG2.11			VADC analog input channel 11 of group 2
	DS3NC			DSADC: negative analog input channel of DSADC 3, pin C
29	AN46	I	D / HighZ / VDDM	Analog input 46
	VADCG2.12			VADC analog input channel 12 of group 24
	DS3PD			DSADC: positive analog input of channel 3, pin D
28	AN47	I	D / HighZ / VDDM	Analog input 47
	VADCG2.13			VADC analog input channel 13 of group 2
	DS3ND			DSADC: negative analog input channel of DSADC 3, pin D
27	AN48	I	D / HighZ / VDDM	Analog input 48
	VADCG2.14			VADC analog input channel 14 of group 2
26	AN49	I	D / HighZ / VDDM	Analog input 49
	VADCG2.15			VADC analog input channel 15 of group 2

Table 2-34 System I/O

Pin	Symbol	Ctrl	Type	Function
121	PORST	I	PORST / PD / VEXT	Power On Reset Input Additional strong PD in case of power fail.
122	ESR0	I/O	MP / OD / VEXT	External System Request Reset 0 Default configuration during and after reset is open-drain driver. The driver drives low during power-on reset. This is valid additionally after deactivation of PORST until the internal reset phase has finished. See also SCU chapter for details. Default after power-on can be different. See also SCU chapter 'Reset Control Unit' and SCU_IOCR register description.
	EVRWUP	I		EVR Wakeup Pin

Package and Pinning Definitions TC265x Pin Definition and Functions:

Table 2-34 System I/O (cont'd)

Pin	Symbol	Ctrl	Type	Function
120	ESR1	I/O	MP / PU1 / VEXT	External System Request Reset 1 Default NMI function. See also SCU chapter 'Reset Control Unit' and SCU_IOCRR register description.
	EVRWUP	I		EVR Wakeup Pin
85	VGATE1P	O	VGATE1P / - / VEXT	External Pass Device gate control for EVR13
112	TMS	I	A2 / PD / VDDP3	JTAG Module State Machine Control Input
	DAP1	I/O		Device Access Port Line 1
114	TRST	I	A2 / PD / VDDP3	JTAG Module Reset/Enable Input
115	TCK	I	A2 / PD / VDDP3	JTAG Module Clock Input
	DAP0	I		Device Access Port Line 0
102	XTAL1	I	XTAL1 / - / -	Main Oscillator/PLL/Clock Generator Input
103	XTAL2	O	XTAL2 / - / -	Main Oscillator/PLL/Clock Generator Output

Table 2-35 Supply

Pin	Symbol	Ctrl	Type	Function
52	VAREF1	I	Vx	Positive Analog Reference Voltage 1
51	VAGND1	I	Vx	Negative Analog Reference Voltage 1
54	VDDM	I	Vx	ADC Analog Power Supply (3.3V / 5V)
10	VDD / VDDSB	I	Vx	Emulation Device: Emulation SRAM Standby Power Supply (1.3V) (Emulation Device only). Production Device: VDD (1.3V).
123, 68, 24	VDD	I	Vx	Digital Core Power Supply (1.3V)
100	VDD	I	Vx	Digital Core Power Supply (1.3V). The supply pin inturn supplies the main XTAL Oscillator/PLL (1.3V) . A higher decoupling capacitor is therefore recommended to the VSS pin for better noise immunity.
153, 99, 69, 25	VEXT	I	Vx	External Supply (5V / 3.3V)

Package and Pinning Definitions TC265x Pin Definition and Functions:

Table 2-35 Supply (cont'd)

Pin	Symbol	Ctrl	Type	Function
154	VDDP3	I	Vx	Digital Power Supply for Flash (3.3V). Can be also used as external 3.3V Power Supply for VFLEX.
104	VDDP3	I	Vx	Digital Power Supply for Oscillator, LVDSH and A2 pads (3.3V). The supply pin inturn supplies the main XTAL Oscillator/PLL (3.3V) . A higher decoupling capacitor is therefore recommended to the VSS pin for better noise immunity.
155	VDDFL3	I	Vx	Flash Power Supply (3.3V)
164	VFLEX	I	Vx	Digital Power Supply for Flex Port Pads (5V / 3.3V)
101	VSS	I	Vx	Digital Ground
53	VSSM	I	Vx	Analog Ground for V _{DDM}

Legend:

Column "Ctrl.":

 I = Input (for GPIO port Lines with IOCR bit field Selection PCx = 0XXX_B)

O = Output

 O0 = Output with IOCR bit field selection PCx = 1X000_B

 O1 = Output with IOCR bit field selection PCx = 1X001_B (ALT1)

 O2 = Output with IOCR bit field selection PCx = 1X010_B (ALT2)

 O3 = Output with IOCR bit field selection PCx = 1X011_B (ALT3)

 O4 = Output with IOCR bit field selection PCx = 1X100_B (ALT4)

 O5 = Output with IOCR bit field selection PCx = 1X101_B (ALT5)

 O6 = Output with IOCR bit field selection PCx = 1X110_B (ALT6)

 O7 = Output with IOCR bit field selection PCx = 1X111_B (ALT7)

Column "Type":

LP = Pad class LP (5V/3.3V, LVTTTL)

MP = Pad class MP (5V/3.3V, LVTTTL)

MP+ = Pad class MP (5V/3.3V, LVTTTL)

A2 = Pad class A2 (3.3V, LVTTTL)

LVDSM = Pad class LVDSM (LVDS/CMOS 5V/3.3V)

LVDSH = Pad class LVDSH (LVDS/CMOS 3.3V)

S = Pad class S (ADC overlaid with General Purpose Input)

D = Pad class D (ADC)

 PU = with pull-up device connected during reset ($\overline{\text{PORST}} = 0$)

 PU1 = with pull-up device connected during reset ($\overline{\text{PORST}} = 0$)^{1) 2) 3)}

 PD = with pull-down device connected during reset ($\overline{\text{PORST}} = 0$)

1) The default state of GPIOs (Px.y) during and after $\overline{\text{PORST}}$ active is controlled via HWCFG[6] (P14.4). HWCFG[6] has a weak internal pull-up active at start-up if the pin is left unconnected. See also User's Manual, "Introduction Chapter", "General Purpose I/O Ports and Peripheral I/O Lines", Figure: "Default state of port pins during and after reset".

Package and Pinning Definitions TC265x Pin Definition and Functions:

PD1 = with pull-down device connected during reset ($\overline{\text{PORST}} = 0$)^{1) 2) 3)}

PX = Behavior depends on usage: PD in EVR13 SMPS Mode and PU1 in GPIO Mode

OD = open drain during reset ($\overline{\text{PORST}} = 0$)

HighZ = tri-state during reset ($\overline{\text{PORST}} = 0$)

PORST = PORST input pad

XTAL1 = XTAL1 input pad

XTAL2 = XTAL2 input pad

VGATE1P = VGATE1P

VGATE3P = VGATE3P

Vx = Supply (the Exposed Pad is also considered as VSS and shall be connected to ground)

NC = These pins are reserved for future extensions and shall not be connected externally

NC1 = These pins are not connected on package level and will not be used for future extensions

NCVDDPSB = This pin has a different functionality in an Production Device and an Emulation Device. For details pls. see Pin/Ball description of this pin.

NCVDDSB = This pin has a different functionality in an Production Device and an Emulation Device. For details pls. see Pin/Ball description of this pin.

2.2.2 Emergency Stop Function

The Emergency Stop function can be used to force GPIOs (General Purpose Inputs/Outputs) via an external input signal (EMGSTOPA or EMGSTOPB) into a defined state:

- Input state and
- PU or High-Z depending on HWCFG[6] level latched during $\overline{\text{PORST}}$ active

Control of the Emergency Stop function:

- The Emergency Stop function can be enabled/disabled in the SCU (see chapter "SCU", "Emergency Stop Control")
- The Emergency Stop input signal, EMGSTOPA (P33.8) / EMGSTOPB (P21.2), can selected in the SCU (see chapter "SCU", "Emergency Stop Control")
- On port level, each GPIO can be enabled/disabled for the Emergency Stop function via the Px_ESR (Port x Emergency Stop) registers in the port control logic (see chapter "General Purpose I/O Ports and Peripheral I/O Lines", "Emergency Stop Register").

The Emergency Stop function is available for all GPIO Ports with the following exceptions:

- Not available for P20.2 (General Purpose Input/GPI only, overlaid with Testmode)
- Not available for P40.x (analog input ANx overlaid with GPI)
- Not available for P32.0 EVR13 SMPS mode.
- Not available for dedicated I/O without General Purpose Output function (e.g ESRx, TMS, TCK)

The Emergency Stop function can be overruled on the following GPIO Ports:

- P00.x and P02.x: Emergency Stop can be overruled by the 8-Bit Standby Controller (SBR), if implemented. Overruling can be disabled via the control registers P00_SCR / P02_SCR (see chapter "General Purpose I/O Ports and Peripheral I/O Lines", P00 / P01)
- P00.x: Emergency Stop can be overruled by the VADC. Overruling can be disabled via the control register P00_SCR (see chapter "General Purpose I/O Ports and Peripheral I/O Lines", P00)
- P14.0 and P14.1: Emergency Stop can be overruled in the DXCPL mode (DAP over can physical layer mode). No Overruling in the DXCM (Debug over can message) mode

2) If HWCFG[6] is left unconnected or is externally pulled high, weak internal pull-ups (PU1) / pull-downs (PD1) are active during and after reset.

3) If HWCFG[6] is connected to ground, the PD1/PU1 pins are predominantly in HighZ during and after reset.

Package and Pinning Definitions TC265x Pin Definition and Functions:

- P21.6: Emergency Stop can be overruled in JTAG mode if this pin is used as TDI
- P21.7: Emergency Stop can be overruled in JTAG or Three Pin DAP mode
- P20.0: Emergency Stop can be overruled in JTAG mode if this GPIO is used as TDI

2.2.3 Pull-Up/Pull-Down Reset Behavior of the Pins

Table 2-36 List of Pull-Up/Pull-Down Reset Behavior of the Pins

Pins	$\overline{\text{PORST}} = 0$	$\overline{\text{PORST}} = 1$
all GPIOs	Pull-up if HWCFG[6] = 1 or High-Z if HWCFG[6] = 0	
$\overline{\text{TDI}}$, $\overline{\text{TESTMODE}}$	Pull-up	
$\overline{\text{PORST}}^{1)}$	Pull-down with I_{PORST} relevant	Pull-down with I_{PDLI} relevant
$\overline{\text{TRST}}$, TCK, TMS	Pull-down	
$\overline{\text{ESR0}}$	The open-drain driver is used to drive low. ²⁾	Pull-up ³⁾
$\overline{\text{ESR1}}$	Pull-up ³⁾	
TDO	Pull-up	High-Z/Pull-up ⁴⁾

1) Pull-down with I_{PORST} relevant is always activated when a primary supply monitor detects a violation.

2) Valid additionally after deactivation of $\overline{\text{PORST}}$ until the internal reset phase has finished. See the SCU chapter for details.

3) See the SCU_IOCRR register description.

4) Depends on JTAG/DAP selection with $\overline{\text{TRST}}$.

In case of leakage test ($\overline{\text{PORST}} = 0$ and $\overline{\text{TESTMODE}} = 0$), the pull-down of the $\overline{\text{TRST}}$ pin is switched off. In case of an user application ($\overline{\text{TESTMODE}} = 1$), the pull-down of the $\overline{\text{TRST}}$ is always switched on.

Package and Pinning Definitions TC267x Pin Definition and Functions:

2.3 TC267x Pin Definition and Functions: BGA292

Figure 2-3 is showing the TC267x Logic Symbol for the package variant: BGA292.

	20	19	18	17	16	15	14	13	12	11	10	9	8	7	6	5	4	3	2	1			
Y	VSS	P32.3	P32.2	P32.0	P33.13	P33.11	P33.9	P33.7	P33.5	P33.3	P33.1	AN5	AN10	VAGND1	VAREF1	VDDM	VSSM	AN20	AN21	NC	Y		
W	VEXT	VSS	P32.4	VGATE1P	P33.12	P33.10	P33.8	P33.6	P33.4	P33.2	P33.0	AN2	AN8	AN11	AN13	AN16	AN18	AN19	AN24	AN25	W		
V	P23.0	VEXT																		AN26	AN27	V	
U	P23.2	P23.1	U	VSS	P32.7	P32.6	P33.15	P34.5	P34.3	P34.1	AN1	AN3	AN7	AN9	AN14	AN17	NC	U		AN28	AN29	U	
T	P23.4	P23.3	T	P23.5	VSS	P32.5	P33.14	P34.4	P34.2	VEVRSB	AND	AN4	AN6	AN12	AN15	AN22	AN30	T	VAGND2	VAREF2	T		
R	P22.2	P22.3	R	P23.6	P23.7	Top-View											AN23	AN31	R	AN35	AN33	R	
P	P22.0	P22.1	P	P22.5	P22.4			VDD	VSS	VSS (AGBT TXDP)	VSS (AGBT TXDN)	VSS	VDD			AN34	AN32	P		AN37	AN39	P	
N	VDDP3	VDD	N	P22.7	P22.6		VDD		VSS	VSS	VSS	VSS		VDD		AN38	AN36	N		AN45	AN44	N	
M	XTAL1	XTAL2	M	P22.9	P22.8		VSS	VSS		VSS	VSS		VSS	VSS		AN40	AN41	M		AN47	AN46	M	
L	VSS	TRST	L	P22.11	P22.10		VSS (AGBT ERR)	VSS	VSS	VSS	VSS	VSS	VSS	VSS		AN42	AN43	L		P00.12	P00.11	L	
K	P21.4	P21.2	K	P21.0	TMS		NC (VDDP3B)	VSS	VSS	VSS	VSS	VSS	VSS	VSS		P00.10	P00.8	K		P00.9	P00.7	K	
J	P21.5	P21.3	J	P21.1	TCK		VSS	VSS		VSS	VSS		VSS	VSS		P01.7	P00.6	J		P00.5	P00.4	J	
H	P20.0	P20.2	H	P21.6	P21.7		VDD		VSS	VSS	VSS	VSS		VDD (VDDSB)		P01.5	P01.6	H		P00.3	P00.2	H	
G	P20.3	P20.1	G	PORST	ESR1			VDD	VSS	VSS	VSS	VSS		VDD (VDDSB)		P01.3	P01.4	G		P00.1	P00.0	G	
F	P20.8	P20.7	F	P20.6	ESR0											P02.10	P02.11	F		P02.7	P02.8	F	
E	P20.11	P20.10	E	P20.9	VSS	VDDFL3	P15.5	P14.2	P12.0	P12.1	P11.0	P11.1	P11.7	P11.8	P11.13	VSS	P02.9	E		P02.5	P02.6	E	
D	P20.13	P20.12	D	VSS	VDDFL3	P15.7	P15.8	P14.7	P14.9	P14.10	P11.4	P11.6	P11.5	P11.14	P11.15	VFLEX	VSS	D		P02.3	P02.4	D	
C	P20.14	P15.2			17	16	15	14	13	12	11	10	9	8	7	6	5	4			P02.1	P02.2	C
B	P15.0	VSS	VDDP3	P15.3	P14.0	P14.4	P14.3	P14.6	P13.0	P13.2	P11.3	P11.10	P11.12	P10.1	P10.4	P10.5	P10.8	VEXT	VSS		P02.0	B	
A	VSS	VDDP3	P15.1	P15.4	P15.6	P14.1	P14.5	P14.8	P13.1	P13.3	P11.2	P11.9	P11.11	P10.0	P10.3	P10.2	P10.6	P10.7	VEXT	NC	A		
	20	19	18	17	16	15	14	13	12	11	10	9	8	7	6	5	4	3	2	1			

Figure 2-3 TC267x Logic Symbol for the package variant BGA292.

2.3.1 TC267 BGA292 Package Variant Pin Configuration

Table 2-37 Port 00 Functions

Pin	Symbol	Ctrl	Type	Function
G1	P00.0	I	MP / PU1 / VEXT	General-purpose input
	TIN9			GTM input
	CTRAPA			CCU61 input
	T12HRE			CCU60 input
	INJ00			MSC0 input
	CIFD9			CIF input
	P00.0	O0		General-purpose output
	TOUT9	O1		GTM output
	ASCLK3	O2		ASCLIN3 output
	ATX3	O3		ASCLIN3 output
	–	O4		Reserved
	TXDCAN1	O5		CAN node 1 output
	–	O6		Reserved
	COU63	O7		CCU60 output
	ETHMDIOA	I/O		ETH input/output
	G2	P00.1		I
TIN10		GTM input		
ARX3E		ASCLIN3 input		
RXDCAN1D		CAN node 1 input		
PSIRX0A		PSI5 input		
SENT0B		SENT input		
CC60INB		CCU60 input		
CC60INA		CCU61 input		
DSCIN0A		DSADC channel 0 input A		
VADCG3.11		VADC analog input channel 11 of group 3		
CIFD10		CIF input		
P00.1		O0	General-purpose output	
TOUT10		O1	GTM output	
ATX3		O2	ASCLIN3 output	
–		O3	Reserved	
DSCOUT0		O4	DSADC channel 0 output	
–		O5	Reserved	
SPC0		O6	SENT output	
CC60	O7	CCU61 output		

Package and Pinning Definitions TC267x Pin Definition and Functions:

Table 2-37 Port 00 Functions (cont'd)

Pin	Symbol	Ctrl	Type	Function
H1	P00.2	I	LP / PU1 / VEXT	General-purpose input
	TIN11			GTM input
	SENT1B			SENT input
	DSDIN0A			DSADC channel 0 input A
	VADCG3.10			VADC analog input channel 10 of group 3 (MD)
	CIFD11			CIF input
	P00.2	O0		General-purpose output
	TOUT11	O1		GTM output
	ASCLK3	O2		ASCLIN3 output
	–	O3		Reserved
	PSITX0	O4		PSI5 output
	TXDCAN3	O5		CAN node 3 output
	–	O6		Reserved
	COOUT60	O7		CCU61 output
H2	P00.3	I	LP / PU1 / VEXT	General-purpose input
	TIN12			GTM input
	RXDCAN3A			CAN node 3 input
	PSIRX1A			PSI5 input
	PSISRXA			PSI5-S input
	SENT2B			SENT input
	CC61INB			CCU60 input
	CC61INA			CCU61 input
	DSCIN3A			DSADC channel 3 input A
	VADCG3.9			VADC analog input channel 9 of group 3 (MD)
	CIFD12			CIF input
	P00.3			O0
	TOUT12	O1		GTM output
	ASLSO3	O2		ASCLIN3 output
	–	O3		Reserved
	DSCOUT3	O4		DSADC channel 3 output
	–	O5		Reserved
	SPC2	O6		SENT output
CC61	O7	CCU61 output		

Package and Pinning Definitions TC267x Pin Definition and Functions:

Table 2-37 Port 00 Functions (cont'd)

Pin	Symbol	Ctrl	Type	Function
J1	P00.4	I	LP / PU1 / VEXT	General-purpose input
	TIN13			GTM input
	REQ7			SCU input
	SENT3B			SENT input
	DSDIN3A			DSADC channel 3 input A
	DSSGNA			DSADC input
	VADCG3.8			VADC analog input channel 8 of group 3
	CIFD13			CIF input
	P00.4			O0
	TOUT13	O1		GTM output
	PSISTX	O2		PSI5-S output
	TXDCAN4	O3		CAN node 4 output
	PSITX1	O4		PSI5 output
	VADCG2BFL0	O5		VADC output
	SPC3	O6		SENT output
	COU61	O7		CCU61 output
	J2	P00.5		I
TIN14		GTM input		
PSIRX2A		PSI5 input		
SENT4B		SENT input		
RXDCAN4A		CAN node 4 input		
CC62INB		CCU60 input		
CC62INA		CCU61 input		
DSCIN2A		DSADC channel 2 input A		
VADCG3.7		VADC analog input channel 7 of group 3		
CIFD14		CIF input		
P00.5		O0	General-purpose output	
TOUT14		O1	GTM output	
DSCGPWMN		O2	DSADC output	
–		O3	Reserved	
DSCOUT2		O4	DSADC channel 2 output	
VADCG2BFL1		O5	VADC output	
SPC4		O6	SENT output	
CC62	O7	CCU61 output		

Package and Pinning Definitions TC267x Pin Definition and Functions:

Table 2-37 Port 00 Functions (cont'd)

Pin	Symbol	Ctrl	Type	Function
J4	P00.6	I	LP / PU1 / VEXT	General-purpose input
	TIN15			GTM input
	SENT5B			SENT input
	DSDIN2A			DSADC channel 2 input A
	VADCG3.6			VADC analog input channel 6 of group 3
	CIFD15			CIF input
	P00.6			O0
	TOUT15	O1		GTM output
	DSCGPWMP	O2		DSADC output
	VADCG2BFL2	O3		VADC output
	PSITX2	O4		PSI5 output
	VADCEMUX10	O5		VADC output
	SPC5	O6		SENT output
	COU62	O7		CCU61 output
K1	P00.7	I	LP / PU1 / VEXT	General-purpose input
	TIN16			GTM input
	CC60INC			CCU61 input
	CCPOS0A			CCU61 input
	T12HRB			CCU60 input
	T2INA			GPT120 input
	VADCG3.5			VADC analog input channel 5 of group 3
	CIFCLK			CIF input
	P00.7	O0		General-purpose output
	TOUT16	O1		GTM output
	–	O2		Reserved
	VADCG2BFL3	O3		VADC output
	–	O4		Reserved
	VADCEMUX11	O5		VADC output
	–	O6		Reserved
	CC60	O7		CCU61 output

Package and Pinning Definitions TC267x Pin Definition and Functions:

Table 2-37 Port 00 Functions (cont'd)

Pin	Symbol	Ctrl	Type	Function
K4	P00.8	I	LP / PU1 / VEXT	General-purpose input
	TIN17			GTM input
	CC61INC			CCU61 input
	CCPOS1A			CCU61 input
	T13HRB			CCU60 input
	T2EUDA			GPT120 input
	VADCG3.4			VADC analog input channel 4 of group 3
	CIFVSNC			CIF input
	P00.8	O0		General-purpose output
	TOUT17	O1		GTM output
	SLSO36	O2		QSPI3 output
	–	O3		Reserved
	–	O4		Reserved
	VADCEMUX12	O5		VADC output
	–	O6		Reserved
	CC61	O7		CCU61 output
K2	P00.9	I	LP / PU1 / VEXT	General-purpose input
	TIN18			GTM input
	CC62INC			CCU61 input
	CCPOS2A			CCU61 input
	T13HRC			CCU60 input
	T12HRC			CCU60 input
	T4EUDA			GPT120 input
	VADCG3.3			VADC analog input channel 3 of group 3
	DSITR3F			DSADC channel 3 input F
	CIFHSNC			CIF input
	P00.9	O0		General-purpose output
	TOUT18	O1		GTM output
	SLSO37	O2		QSPI3 output
	ARTS3	O3		ASCLIN3 output
	–	O4		Reserved
	–	O5		Reserved
–	O6	Reserved		
CC62	O7	CCU61 output		

Package and Pinning Definitions TC267x Pin Definition and Functions:

Table 2-37 Port 00 Functions (cont'd)

Pin	Symbol	Ctrl	Type	Function	
K5	P00.10	I	LP / PU1 / VEXT	General-purpose input	
	TIN19			GTM input	
	VADCG3.2			VADC analog input channel 2 of group 3 (MD)	
	P00.10	O0		General-purpose output	
	TOUT19	O1		GTM output	
	–	O2		Reserved	
	–	O3		Reserved	
	–	O4		Reserved	
	–	O5		Reserved	
	–	O6		Reserved	
	COU63	O7	CCU61 output		
L1	P00.11	I	LP / PU1 / VEXT	General-purpose input	
	TIN20			GTM input	
	CTRAPA			CCU60 input	
	T12HRE			CCU61 input	
	VADCG3.1			VADC analog input channel of group 3	
	P00.11	O0		General-purpose output	
	TOUT20	O1		GTM output	
	–	O2		Reserved	
	–	O3		Reserved	
	DSCOUT0	O4		DSADC channel 0 output	
	–	O5		Reserved	
	–	O6		Reserved	
	–	O7		Reserved	
L2	P00.12	I	LP / PU1 / VEXT	General-purpose input	
	TIN21			GTM input	
	ACTS3A			ASCLIN3 input	
	VADCG3.0			VADC analog input channel 0 of group 3	
	P00.12	O0		General-purpose output	
	TOUT21	O1		GTM output	
	–	O2		Reserved	
	–	O3		Reserved	
	–	O4		Reserved	
	–	O5		Reserved	
	–	O6		Reserved	
		COU63		O7	CCU61 output

Package and Pinning Definitions TC267x Pin Definition and Functions:

Table 2-38 Port 02 Functions

Pin	Symbol	Ctrl	Type	Function
B1	P02.0	I	MP+ / PU1 / VEXT	General-purpose input
	TIN0			GTM input
	ARX2G			ASCLIN2 input
	REQ6			SCU input
	CC60INA			CCU60 input
	CC60INB			CCU61 input
	CIFD0			CIF input
	P02.0	O0		General-purpose output
	TOUT0	O1		GTM output
	ATX2	O2		ASCLIN2 output
	SLSO31	O3		QSPI3 output
	DSCGPWMN	O4		DSADC output
	TXDCAN0	O5		CAN node 0 output
	TXDA	O6		ERAY output
	CC60	O7		CCU60 output
	C2	P02.1		I
TIN1		GTM input		
REQ14		SCU input		
ARX2B		ASCLIN2 input		
RXDCAN0A		CAN node 0 input		
RXDA2		ERAY input		
CIFD1		CIF input		
P02.1		O0	General-purpose output	
TOUT1		O1	GTM output	
–		O2	Reserved	
SLSO32		O3	QSPI3 output	
DSCGPWMP		O4	DSADC output	
–		O5	Reserved	
–		O6	Reserved	
COU60		O7	CCU60 output	

Package and Pinning Definitions TC267x Pin Definition and Functions:

Table 2-38 Port 02 Functions (cont'd)

Pin	Symbol	Ctrl	Type	Function
C1	P02.2	I	MP+ / PU1 / VEXT	General-purpose input
	TIN2			GTM input
	CC61INA			CCU60 input
	CC61INB			CCU61 input
	CIFD2			CIF input
	P02.2	O0		General-purpose output
	TOUT2	O1		GTM output
	ATX1	O2		ASCLIN1 output
	SLSO33	O3		QSPI3 output
	PSITX0	O4		PSI5 output
	TXDCAN2	O5		CAN node 2 output
	TXDB	O6		ERAY output
	CC61	O7		CCU60 output
	D2	P02.3		I
TIN3		GTM input		
ARX1G		ASCLIN1 input		
RXDCAN2B		CAN node 2 input		
RXDB2		ERAY input		
PSIRX0B		PSI5 input		
SDI11		MSC1 input		
CIFD3		CIF input		
P02.3		O0	General-purpose output	
TOUT3		O1	GTM output	
ASLSO2		O2	ASCLIN2 output	
SLSO34		O3	QSPI3 output	
–		O4	Reserved	
–		O5	Reserved	
–		O6	Reserved	
COUT61		O7	CCU60 output	

Package and Pinning Definitions TC267x Pin Definition and Functions:

Table 2-38 Port 02 Functions (cont'd)

Pin	Symbol	Ctrl	Type	Function
D1	P02.4	I	MP+ / PU1 / VEXT	General-purpose input
	TIN4			GTM input
	SLSI3A			QSPI3 input
	ECTT1			TTCAN input
	RXDCAN0D			CAN node 0 input
	CC62INA			CCU60 input
	CC62INB			CCU61 input
	SDA0A			I2C0 input
	CIFD4			CIF input
	P02.4			O0
	TOUT4	O1		GTM output
	ASCLK2	O2		ASCLIN2 output
	SLSO30	O3		QSPI3 output
	PSISCLK	O4		PSI5-S output
	SDA0	O5		I2C0 output
	TXENA	O6		ERAY output
	CC62	O7		CCU60 output
E2	P02.5	I	MP+ / PU1 / VEXT	General-purpose input
	TIN5			GTM input
	MRST3A			QSPI3 input
	ECTT2			TTCAN input
	PSIRX1B			PSI5 input
	PSISRXB			PSI5-S input
	SENT3C			SENT input
	SCL0A			I2C0 input
	CIFD5			CIF input
	P02.5			O0
	TOUT5	O1		GTM output
	TXDCAN0	O2		CAN node 0 output
	MRST3	O3		QSPI3 output
	–	O4		Reserved
	SCL0	O5		I2C0 output
	TXENB	O6		ERAY output
	COU62	O7		CCU60 output

Package and Pinning Definitions TC267x Pin Definition and Functions:

Table 2-38 Port 02 Functions (cont'd)

Pin	Symbol	Ctrl	Type	Function		
E1	P02.6	I	MP / PU1 / VEXT	General-purpose input		
	TIN6			GTM input		
	MTSR3A			QSPI3 input		
	SENT2C			SENT input		
	CC60INC			CCU60 input		
	CCPOS0A			CCU60 input		
	T12HRB			CCU61 input		
	T3INA			GPT120 input		
	CIFD6			CIF input		
	P02.6	O0		General-purpose output		
	TOUT6	O1		GTM output		
	PSISTX	O2		PSI5-S output		
	MTSR3	O3		QSPI3 output		
	PSITX1	O4		PSI5 output		
	VADCEMUX00	O5		VADC output		
	–	O6		Reserved		
	CC60	O7		CCU60 output		
	F2	P02.7		I	MP / PU1 / VEXT	General-purpose input
		TIN7				GTM input
SCLK3A		QSPI3 input				
PSIRX2B		PSI5 input				
SENT1C		SENT input				
CC61INC		CCU60 input				
CCPOS1A		CCU60 input				
T13HRB		CCU61 input				
T3EUDA		GPT120 input				
CIFD7		CIF input				
DSCIN3B		DSADC channel 3 input B				
P02.7		O0	General-purpose output			
TOUT7		O1	GTM output			
–		O2	Reserved			
SCLK3		O3	QSPI3 output			
DSCOUT3		O4	DSADC channel 3 output			
VADCEMUX01		O5	VADC output			
SPC1		O6	SENT output			
CC61		O7	CCU60 output			

Package and Pinning Definitions TC267x Pin Definition and Functions:

Table 2-38 Port 02 Functions (cont'd)

Pin	Symbol	Ctrl	Type	Function
F1	P02.8	I	LP / PU1 / VEXT	General-purpose input
	TIN8			GTM input
	SENT0C			SENT input
	CC62INC			CCU60 input
	CCPOS2A			CCU60 input
	T12HRC			CCU61 input
	T13HRC			CCU61 input
	T4INA			GPT120 input
	CIFD8			CIF input
	DSDIN3B			DSADC channel 3 input B
	DSITR3E			DSADC channel 3 input E
	P02.8			O0
	TOUT8	O1	GTM output	
	SLSO35	O2	QSPI3 output	
	–	O3	Reserved	
	PSITX2	O4	PSI5 output	
	VADCEMUX02	O5	VADC output	
	ETHMDC	O6	ETH output	
	CC62	O7	CCU60 output	

Table 2-39 Port 10 Functions

Pin	Symbol	Ctrl	Type	Function
A7	P10.0	I	LP / PU1 / VEXT	General-purpose input
	TIN102			GTM input
	T6EUDB			GPT120 input
	P10.0	O0		General-purpose output
	TOUT102	O1		GTM output
	–	O2		Reserved
	SLSO110	O3		QSPI1 output
	–	O4		Reserved
	VADCG3BFL0	O5		VADC output
	–	O6		Reserved
	–	O7		Reserved

Package and Pinning Definitions TC267x Pin Definition and Functions:

Table 2-39 Port 10 Functions (cont'd)

Pin	Symbol	Ctrl	Type	Function
B7	P10.1	I	MP+ / PU1 / VEXT	General-purpose input
	TIN103			GTM input
	MRST1A			QSPI1 input
	T5EUDB			GPT120 input
	P10.1	O0		General-purpose output
	TOUT103	O1		GTM output
	MTSR1	O2		QSPI1 output
	MRST1	O3		QSPI1 output
	EN01	O4		MSC0 output
	VADCG3BFL1	O5		VADC output
	END03	O6		MSC0 output
	–	O7		Reserved
A5	P10.2	I	MP / PU1 / VEXT	General-purpose input
	TIN104			GTM input
	SCLK1A			QSPI1 input
	T6INB			GPT120 input
	REQ2			SCU input
	RXDCAN2E			CAN node 2 input
	SDI01			MSC0 input
	P10.2	O0		General-purpose output
	TOUT104	O1		GTM output
	–	O2		Reserved
	SCLK1	O3		QSPI1 output
	EN00	O4		MSC0 output
	VADCG3BFL2	O5		VADC output
	END02	O6		MSC0 output
	–	O7		Reserved

Package and Pinning Definitions TC267x Pin Definition and Functions:

Table 2-39 Port 10 Functions (cont'd)

Pin	Symbol	Ctrl	Type	Function
A6	P10.3	I	MP / PU1 / VEXT	General-purpose input
	TIN105			GTM input
	MTSR1A			QSPI1 input
	REQ3			SCU input
	T5INB			GPT120 input
	P10.3	O0		General-purpose output
	TOUT105	O1		GTM output
	VADCG3BFL3	O2		VADC output
	MTSR1	O3		QSPI1 output
	EN00	O4		MSC0 output
	END02	O5		MSC0 output
	TXDCAN2	O6		CAN node 2 output
	–	O7		Reserved
	B6	P10.4		I
TIN106		GTM input		
MTSR1C		QSPI1 input		
CCPOS0C		CCU60 input		
T3INB		GPT120 input		
P10.4		O0	General-purpose output	
TOUT106		O1	GTM output	
–		O2	Reserved	
SLSO18		O3	QSPI1 output	
MTSR1		O4	QSPI1 output	
EN00		O5	MSC0 output	
END02		O6	MSC0 output	
–		O7	Reserved	

Package and Pinning Definitions TC267x Pin Definition and Functions:

Table 2-39 Port 10 Functions (cont'd)

Pin	Symbol	Ctrl	Type	Function
B5	P10.5	I	LP / PU1 / VEXT	General-purpose input
	TIN107			GTM input
	HWCFG4			SCU input
	RXDCAN4B			CAN node 4 input
	INJ01			MSC0 input
	P10.5	O0		General-purpose output
	TOUT107	O1		GTM output
	ATX2	O2		ASCLIN2 output
	SLSO38	O3		QSPI3 output
	SLSO19	O4		QSPI1 output
	T6OUT	O5		GPT120 output
	ASLSO2	O6		ASCLIN2 output
	–	O7		Reserved
	A4	P10.6		I
TIN108		GTM input		
ARX2D		ASCLIN2 input		
MTSR3B		QSPI3 input		
HWCFG5		SCU input		
P10.6		O0	General-purpose output	
TOUT108		O1	GTM output	
ASCLK2		O2	ASCLIN2 output	
MTSR3		O3	QSPI3 output	
T3OUT		O4	GPT120 output	
TXDCAN4		O5	CAN node 4 output	
MRST1		O6	QSPI1 output	
VADCG3BFL0		O7	VADC output	

Package and Pinning Definitions TC267x Pin Definition and Functions:

Table 2-39 Port 10 Functions (cont'd)

Pin	Symbol	Ctrl	Type	Function	
A3	P10.7	I	LP / PU1 / VEXT	General-purpose input	
	TIN109			GTM input	
	ACTS2A			ASCLIN2 input	
	MRST3B			QSPI3 input	
	REQ4			SCU input	
	CCPOS1C			CCU60 input	
	T3EUDB			GPT120 input	
	P10.7			O0	General-purpose output
	TOUT109	O1		GTM output	
	–	O2		Reserved	
	MRST3	O3		QSPI3 output	
	VADCG3BFL1	O4		VADC output	
	–	O5		Reserved	
	–	O6		Reserved	
–	O7	Reserved			
B4	P10.8	I	LP / PU1 / VEXT	General-purpose input	
	TIN110			GTM input	
	SCLK3B			QSPI3 input	
	REQ5			SCU input	
	CCPOS2C			CCU60 input	
	T4INB			GPT120 input	
	P10.8			O0	General-purpose output
	TOUT110			O1	GTM output
	ARTS2	O2		ASCLIN2 output	
	SCLK3	O3		QSPI3 output	
	–	O4		Reserved	
	–	O5		Reserved	
	–	O6		Reserved	
	–	O7		Reserved	

Package and Pinning Definitions TC267x Pin Definition and Functions:

Table 2-40 Port 11 Functions

Pin	Symbol	Ctrl	Type	Function
A10	P11.2	I	MPR / PU1 / VFLEX	General-purpose input
	TIN95			GTM input
	P11.2	O0		General-purpose output
	TOUT95	O1		GTM output
	END03	O2		MSC0 output
	SLSO05	O3		QSPI0 output
	SLSO15	O4		QSPI1 output
	EN01	O5		MSC0 output
	ETHTXD1	O6		ETH output
	COUT63	O7		CCU60 output
B10	P11.3	I	MPR / PU1 / VFLEX	General-purpose input
	TIN96			GTM input
	MRST1B			QSPI1 input
	SDI03			MSC0 input
	P11.3	O0		General-purpose output
	TOUT96	O1		GTM output
	–	O2		Reserved
	MRST1	O3		QSPI1 output
	TXDA	O4		ERAY output
	–	O5		Reserved
	ETHTXD0	O6		ETH output
	COUT62	O7		CCU60 output
D9	P11.6	I	MPR / PU1 / VFLEX	General-purpose input
	TIN97			GTM input
	SCLK1B			QSPI1 input
	P11.6	O0		General-purpose output
	TOUT97	O1		GTM output
	TXENB	O2		ERAY output
	SCLK1	O3		QSPI1 output
	TXENA	O4		ERAY output
	FCLP0	O5		MSC0 output
	ETHTXEN	O6		ETH output
	COUT61	O7		CCU60 output

Package and Pinning Definitions TC267x Pin Definition and Functions:

Table 2-40 Port 11 Functions (cont'd)

Pin	Symbol	Ctrl	Type	Function
A9	P11.9	I	MP+ / PU1 / VFLEX	General-purpose input
	TIN98			GTM input
	MTSR1B			QSPI1 input
	RXDA1			ERAY input
	ETHRXD1			ETH input
	P11.9	O0		General-purpose output
	TOUT98	O1		GTM output
	–	O2		Reserved
	MTSR1	O3		QSPI1 output
	–	O4		Reserved
	SOP0	O5		MSC0 output
	–	O6		Reserved
	COUT60	O7		CCU60 output
B9	P11.10	I	LP / PU1 / VFLEX	General-purpose input
	TIN99			GTM input
	REQ12			SCU input
	ARX1E			ASCLIN1 input
	SLSI1A			QSPI1 input
	RXDCAN3D			CAN node 3 input
	RXDB1			ERAY input
	ETHRXD0			ETH input
	SDI00			MSC0 input
	P11.10	O0		General-purpose output
	TOUT99	O1		GTM output
	–	O2		Reserved
	SLSO03	O3		QSPI0 output
	SLSO13	O4		QSPI1 output
	–	O5		Reserved
	–	O6		Reserved
	CC62	O7		CCU60 output

Package and Pinning Definitions TC267x Pin Definition and Functions:

Table 2-40 Port 11 Functions (cont'd)

Pin	Symbol	Ctrl	Type	Function
A8	P11.11	I	MP+ / PU1 / VFLEX	General-purpose input
	TIN100			GTM input
	ETHCRSDVA			ETH input
	P11.11	O0		General-purpose output
	TOUT100	O1		GTM output
	END02	O2		MSC0 output
	SLSO04	O3		QSPI0 output
	SLSO14	O4		QSPI1 output
	EN00	O5		MSC0 output
	TXENB	O6		ERAY output
	CC61	O7		CCU60 output
B8	P11.12	I	MPR / PU1 / VFLEX	General-purpose input
	TIN101			GTM input
	ETHREFCLK			ETH input
	ETHTXCLKB			ETH input (Not for productive purposes)
	ETHRXCLKA			ETH input (Not for productive purposes)
	P11.12	O0		General-purpose output
	TOUT101	O1		GTM output
	ATX1	O2		ASCLIN1 output
	GTMCLK2	O3		GTM output
	TXDB	O4		ERAY output
	TXDCAN3	O5		CAN node 3 output
	EXTCLK1	O6		SCU output
	CC60	O7		CCU60 output

Table 2-41 Port 13 Functions

Pin	Symbol	Ctrl	Type	Function
B12	P13.0	I	LVDSM_N / PU1 / VEXT	General-purpose input
	TIN91			GTM input
	P13.0	O0		General-purpose output
	TOUT91	O1		GTM output
	END03	O2		MSC0 output
	SCLK2N	O3		QSPI2 output (LVDS)
	EN01	O4		MSC0 output
	FCLN0	O5		MSC0 output (LVDS)
	FCLND0	O6		MSC0 output (LVDS)
	TXDCAN4	O7		CAN node 4 output

Package and Pinning Definitions TC267x Pin Definition and Functions:

Table 2-41 Port 13 Functions (cont'd)

Pin	Symbol	Ctrl	Type	Function
A12	P13.1	I	LVDSM_P / PU1 / VEXT	General-purpose input
	TIN92			GTM input
	SCL0B			I2C0 input
	RXDCAN4C			CAN node 4 input
	P13.1	O0		General-purpose output
	TOUT92	O1		GTM output
	–	O2		Reserved
	SCLK2P	O3		QSPI2 output (LVDS)
	–	O4		Reserved
	FCLP0	O5		MSC0 output (LVDS)
	SCL0	O6		I2C0 output
	–	O7		Reserved
	B11	P13.2		I
TIN93		GTM input		
CAPINA		GPT120 input		
SDA0B		I2C0 input		
P13.2		O0	General-purpose output	
TOUT93		O1	GTM output	
–		O2	Reserved	
MUSR2N		O3	QSPI2 output (LVDS)	
FCLP0		O4	MSC0 output	
SON0		O5	MSC0 output (LVDS)	
SDA0		O6	I2C0 output	
SOND0		O7	MSC0 output (LVDS)	
A11		P13.3	I	LVDSM_P / PU1 / VEXT
	TIN94	GTM input		
	P13.3	O0	General-purpose output	
	TOUT94	O1	GTM output	
	–	O2	Reserved	
	MUSR2P	O3	QSPI2 output (LVDS)	
	–	O4	Reserved	
	SOP0	O5	MSC0 output (LVDS)	
	–	O6	Reserved	
	–	O7	Reserved	

Package and Pinning Definitions TC267x Pin Definition and Functions:

Table 2-42 Port 14 Functions

Pin	Symbol	Ctrl	Type	Function
B16	P14.0	I	MP+ / PU1 / VEXT	General-purpose input
	TIN80			GTM input
	P14.0	O0		General-purpose output
	TOUT80	O1		GTM output
	ATX0	O2		ASCLIN0 output Recommended as Boot loader pin.
	TXDA	O3		ERAY output
	TXDB	O4		ERAY output
	TXDCAN1	O5		CAN node 1 output Used for single pin DAP (SPD) function.
	ASCLK0	O6		ASCLIN0 output
	COU62	O7		CCU60 output
A15	P14.1	I	MP / PU1 / VEXT	General-purpose input
	TIN81			GTM input
	REQ15			SCU input
	ARX0A			ASCLIN0 input
	RXDCAN1B			CAN node 1 input Used for single pin DAP (SPD) function.
	RXDA3			ERAY input
	RXDB3			ERAY input
	EVWUPA			SCU input
	P14.1	O0		General-purpose output
	TOUT81	O1		GTM output
	ATX0	O2		ASCLIN0 output Recommended as Boot loader pin.
	–	O3		Reserved
	–	O4		Reserved
	–	O5		Reserved
	–	O6		Reserved
	COU63	O7		CCU60 output

Package and Pinning Definitions TC267x Pin Definition and Functions:

Table 2-42 Port 14 Functions (cont'd)

Pin	Symbol	Ctrl	Type	Function
E13	P14.2	I	LP / PU1 / VEXT	General-purpose input
	TIN82			GTM input
	HWCFG2 EVR13			SCU input Latched at cold power on reset to decide EVR13 activation.
	P14.2	O0		General-purpose output
	TOUT82	O1		GTM output
	ATX2	O2		ASCLIN2 output
	SLSO21	O3		QSPI2 output
	–	O4		Reserved
	–	O5		Reserved
	ASCLK2	O6		ASCLIN2 output
–	O7	Reserved		
B14	P14.3	I	LP / PU1 / VEXT	General-purpose input
	TIN83			GTM input
	ARX2A			ASCLIN2 input
	REQ10			SCU input
	HWCFG3_BMI			SCU input
	SDI02			MSC0 input
	P14.3	O0		General-purpose output
	TOUT83	O1		GTM output
	ATX2	O2		ASCLIN2 output
	SLSO23	O3		QSPI2 output
	ASLSO1	O4		ASCLIN1 output
	ASLSO3	O5		ASCLIN3 output
	–	O6		Reserved
	–	O7		Reserved

Package and Pinning Definitions TC267x Pin Definition and Functions:

Table 2-42 Port 14 Functions (cont'd)

Pin	Symbol	Ctrl	Type	Function
B15	P14.4	I	LP / PU1 / VEXT	General-purpose input
	TIN84			GTM input
	HWCFG6			SCU input Latched at cold power on reset to decide default pad reset state (PU or HighZ).
	P14.4	O0		General-purpose output
	TOUT84	O1		GTM output
	–	O2		Reserved
	–	O3		Reserved
	–	O4		Reserved
	–	O5		Reserved
	–	O6		Reserved
–	O7	Reserved		
A14	P14.5	I	MP+ / PU1 / VEXT	General-purpose input
	TIN85			GTM input
	HWCFG1 EVR33			SCU input Latched at cold power on reset to decide EVR33 activation.
	P14.5	O0		General-purpose output
	TOUT85	O1		GTM output
	–	O2		Reserved
	–	O3		Reserved
	–	O4		Reserved
	–	O5		Reserved
	TXDB	O6		ERAY output
–	O7	Reserved		
B13	P14.6	I	MP+ / PU1 / VEXT	General-purpose input
	TIN86			GTM input
	HWCFG0 DCLDO			SCU input If EVR13 active, latched at cold power on reset to decide between LDO and SMPS mode.
	P14.6	O0		General-purpose output
	TOUT86	O1		GTM output
	–	O2		Reserved
	SLSO22	O3		QSPI2 output
	–	O4		Reserved
	–	O5		Reserved
	TXENB	O6		ERAY output
–	O7	Reserved		

Package and Pinning Definitions TC267x Pin Definition and Functions:

Table 2-42 Port 14 Functions (cont'd)

Pin	Symbol	Ctrl	Type	Function
D13	P14.7	I	LP / PU1 / VEXT	General-purpose input
	TIN87			GTM input
	RXDB0			ERAY input
	P14.7	O0		General-purpose output
	TOUT87	O1		GTM output
	ARTS0	O2		ASCLIN0 output
	SLSO24	O3		QSPI2 output
	–	O4		Reserved
	–	O5		Reserved
	–	O6		Reserved
	–	O7		Reserved
A13	P14.8	I	LP / PU1 / VEXT	General-purpose input
	TIN88			GTM input
	ARX1D			ASCLIN1 input
	RXDCAN2D			CAN node 2 input
	RXDA0			ERAY input
	P14.8	O0		General-purpose output
	TOUT88	O1		GTM output
	–	O2		Reserved
	–	O3		Reserved
	–	O4		Reserved
	–	O5		Reserved
	–	O6		Reserved
	–	O7		Reserved
D12	P14.9	I	MP+ / PU1 / VEXT	General-purpose input
	TIN89			GTM input
	ACTS0A			ASCLIN0 input
	P14.9	O0		General-purpose output
	TOUT89	O1		GTM output
	END03	O2		MSC0 output
	EN01	O3		MSC0 output
	–	O4		Reserved
	TXENB	O5		ERAY output
	TXENA	O6		ERAY output
	–	O7		Reserved

Package and Pinning Definitions TC267x Pin Definition and Functions:

Table 2-42 Port 14 Functions (cont'd)

Pin	Symbol	Ctrl	Type	Function
D11	P14.10	I	MP+ / PU1 / VEXT	General-purpose input
	TIN90			GTM input
	P14.10	O0		General-purpose output
	TOUT90	O1		GTM output
	END02	O2		MSC0 output
	EN00	O3		MSC0 output
	ATX1	O4		ASCLIN1 output
	TXDCAN2	O5		CAN node 2 output
	TXDA	O6		ERAY output
	–	O7		Reserved

Table 2-43 Port 15 Functions

Pin	Symbol	Ctrl	Type	Function
B20	P15.0	I	LP / PU1 / VEXT	General-purpose input
	TIN71			GTM input
	P15.0	O0		General-purpose output
	TOUT71	O1		GTM output
	ATX1	O2		ASCLIN1 output
	SLSO013	O3		QSPI0 output
	–	O4		Reserved
	TXDCAN2	O5		CAN node 2 output
	ASCLK1	O6		ASCLIN1 output
	–	O7		Reserved
A18	P15.1	I	LP / PU1 / VEXT	General-purpose input
	TIN72			GTM input
	REQ16			SCU input
	ARX1A			ASCLIN1 input
	RXDCAN2A			CAN node 2 input
	SLSI2B			QSPI2 input
	EVRWUPB			SCU input
	P15.1			O0
	TOUT72	O1		GTM output
	ATX1	O2		ASCLIN1 output
	SLSO25	O3		QSPI2 output
	–	O4		Reserved
	–	O5		Reserved
	–	O6		Reserved
	–	O7		Reserved

Package and Pinning Definitions TC267x Pin Definition and Functions:

Table 2-43 Port 15 Functions (cont'd)

Pin	Symbol	Ctrl	Type	Function
C19	P15.2	I	MP / PU1 / VEXT	General-purpose input
	TIN73			GTM input
	SLSI2A			QSPI2 input
	MRST2E			QSPI2 input
	HSIC2INA			QSPI2 input
	P15.2	O0		General-purpose output
	TOUT73	O1		GTM output
	ATX0	O2		ASCLIN0 output
	SLSO20	O3		QSPI2 output
	–	O4		Reserved
	TXDCAN1	O5		CAN node 1 output
	ASCLK0	O6		ASCLIN0 output
	–	O7		Reserved
	B17	P15.3		I
TIN74		GTM input		
ARX0B		ASCLIN0 input		
SCLK2A		QSPI2 input		
RXDCAN1A		CAN node 1 input		
HSIC2INB		QSPI2 input		
P15.3		O0	General-purpose output	
TOUT74		O1	GTM output	
ATX0		O2	ASCLIN0 output	
SCLK2		O3	QSPI2 output	
END03		O4	MSC0 output	
EN01		O5	MSC0 output	
–		O6	Reserved	
–		O7	Reserved	

Package and Pinning Definitions TC267x Pin Definition and Functions:

Table 2-43 Port 15 Functions (cont'd)

Pin	Symbol	Ctrl	Type	Function	
A17	P15.4	I	MP / PU1 / VEXT	General-purpose input	
	TIN75			GTM input	
	MRST2A			QSPI2 input	
	REQ0			SCU input	
	SCL0C			I2C0 input	
	P15.4	O0		General-purpose output	
	TOUT75	O1		GTM output	
	ATX1	O2		ASCLIN1 output	
	MRST2	O3		QSPI2 output	
	–	O4		Reserved	
	–	O5		Reserved	
	SCL0	O6		I2C0 output	
	CC62	O7		CCU60 output	
E14	P15.5	I	MP / PU1 / VEXT	General-purpose input	
	TIN76			GTM input	
	ARX1B			ASCLIN1 input	
	MTSR2A			QSPI2 input	
	SDA0C			I2C0 input	
	REQ13	SCU input			
	P15.5	O0		General-purpose output	
	TOUT76	O1		GTM output	
	ATX1	O2		ASCLIN1 output	
	MTSR2	O3		QSPI2 output	
	END02	O4		MSC0 output	
	EN00	O5		MSC0 output	
	SDA0	O6		I2C0 output	
CC61	O7	CCU60 output			
A16	P15.6	I	MP / PU1 / VEXT	General-purpose input	
	TIN77			GTM input	
	MTSR2B			QSPI2 input	
	P15.6			O0	General-purpose output
	TOUT77			O1	GTM output
	ATX3	O2		ASCLIN3 output	
	MTSR2	O3		QSPI2 output	
	–	O4		Reserved	
	SCLK2	O5		QSPI2 output	
	ASCLK3	O6		ASCLIN3 output	
	CC60	O7		CCU60 output	

Package and Pinning Definitions TC267x Pin Definition and Functions:

Table 2-43 Port 15 Functions (cont'd)

Pin	Symbol	Ctrl	Type	Function
D15	P15.7	I	MP / PU1 / VEXT	General-purpose input
	TIN78			GTM input
	ARX3A			ASCLIN3 input
	MRST2B			QSPI2 input
	P15.7	O0		General-purpose output
	TOUT78	O1		GTM output
	ATX3	O2		ASCLIN3 output
	MRST2	O3		QSPI2 output
	–	O4		Reserved
	–	O5		Reserved
	–	O6		Reserved
	COUT60	O7		CCU60 output
	D14	P15.8		I
TIN79		GTM input		
SCLK2B		QSPI2 input		
REQ1		SCU input		
P15.8		O0	General-purpose output	
TOUT79		O1	GTM output	
–		O2	Reserved	
SCLK2		O3	QSPI2 output	
–		O4	Reserved	
–		O5	Reserved	
ASCLK3		O6	ASCLIN3 output	
COUT61		O7	CCU60 output	

Package and Pinning Definitions TC267x Pin Definition and Functions:

Table 2-44 Port 20 Functions

Pin	Symbol	Ctrl	Type	Function
H20	P20.0	I	MP / PU1 / VEXT	General-purpose input
	TIN59			GTM input
	RXDCAN3C			CAN node 3 input
	T6EUDA			GPT120 input
	REQ9			SCU input
	SYSClk			HSCT input
	TGI0			OCDS input
	P20.0	O0		General-purpose output
	TOUT59	O1		GTM output
	ATX3	O2		ASCLIN3 output
	ASCLK3	O3		ASCLIN3 output
	–	O4		Reserved
	SYSClk	O5		HSCT output
	–	O6		Reserved
	–	O7		Reserved
	TGO0	HWOUT		OCDS; ENx
	G19	P20.1		I
TIN60		GTM input		
TGI1		OCDS input		
P20.1		O0	General-purpose output	
TOUT60		O1	GTM output	
–		O2	Reserved	
–		O3	Reserved	
–		O4	Reserved	
–		O5	Reserved	
–		O6	Reserved	
–		O7	Reserved	
TGO1		HWOUT	OCDS; ENx	

Package and Pinning Definitions TC267x Pin Definition and Functions:

Table 2-44 Port 20 Functions (cont'd)

Pin	Symbol	Ctrl	Type	Function
H19	P20.2	I	LP / PU / VEXT	General-purpose input This pin is latched at power on reset release to enter test mode.
	TESTMODE			OCDS input
	P20.2	O0		Output function not available
	–	O1		Output function not available
	–	O2		Output function not available
	–	O3		Output function not available
	–	O4		Output function not available
	–	O5		Output function not available
	–	O6		Output function not available
	–	O7		Output function not available
G20	P20.3	I	LP / PU1 / VEXT	General-purpose input
	TIN61			GTM input
	T6INA			GPT120 input
	ARX3C			ASCLIN3 input
	P20.3	O0		General-purpose output
	TOUT61	O1		GTM output
	ATX3	O2		ASCLIN3 output
	SLSO09	O3		QSPI0 output
	SLSO29	O4		QSPI2 output
	TXDCAN3	O5		CAN node 3 output
	–	O6		Reserved
	–	O7		Reserved
F17	P20.6	I	LP / PU1 / VEXT	General-purpose input
	TIN62			GTM input
	P20.6	O0		General-purpose output
	TOUT62	O1		GTM output
	ARTS1	O2		ASCLIN1 output
	SLSO08	O3		QSPI0 output
	SLSO28	O4		QSPI2 output
	–	O5		Reserved
	–	O6		Reserved
	–	O7		Reserved

Package and Pinning Definitions TC267x Pin Definition and Functions:

Table 2-44 Port 20 Functions (cont'd)

Pin	Symbol	Ctrl	Type	Function
F19	P20.7	I	LP / PU1 / VEXT	General-purpose input
	TIN63			GTM input
	ACTS1A			ASCLIN1 input
	RXDCAN0B			CAN node 0 input
	P20.7	O0		General-purpose output
	TOUT63	O1		GTM output
	–	O2		Reserved
	–	O3		Reserved
	–	O4		Reserved
	–	O5		Reserved
	WDT1LCK	O6		SCU output
	COUT63	O7		CCU61 output
F20	P20.8	I	MP / PU1 / VEXT	General-purpose input
	TIN64			GTM input
	P20.8	O0		General-purpose output
	TOUT64	O1		GTM output
	ASLSO1	O2		ASCLIN1 output
	SLSO00	O3		QSPI0 output
	SLSO10	O4		QSPI1 output
	TXDCAN0	O5		CAN node 0 output
	WDT0LCK	O6		SCU output
	CC60	O7		CCU61 output
E17	P20.9	I	LP / PU1 / VEXT	General-purpose input
	TIN65			GTM input
	ARX1C			ASCLIN1 input
	RXDCAN3E			CAN node 3 input
	REQ11			SCU input
	SLSI0B			QSPI0 input
	P20.9			O0
	TOUT65	O1		GTM output
	–	O2		Reserved
	SLSO01	O3		QSPI0 output
	SLSO11	O4		QSPI1 output
	–	O5		Reserved
	WDTSLCK	O6		SCU output
	CC61	O7		CCU61 output

Package and Pinning Definitions TC267x Pin Definition and Functions:

Table 2-44 Port 20 Functions (cont'd)

Pin	Symbol	Ctrl	Type	Function
E19	P20.10	I	MP / PU1 / VEXT	General-purpose input
	TIN66			GTM input
	P20.10			General-purpose output
	TOUT66	O1		GTM output
	ATX1	O2		ASCLIN1 output
	SLSO06	O3		QSPI0 output
	SLSO27	O4		QSPI2 output
	TXDCAN3	O5		CAN node 3 output
	ASCLK1	O6		ASCLIN1 output
	CC62	O7		CCU61 output
E20	P20.11	I	MP / PU1 / VEXT	General-purpose input
	TIN67			GTM input
	SCLK0A			QSPI0 input
	P20.11	O0		General-purpose output
	TOUT67	O1		GTM output
	–	O2		Reserved
	SCLK0	O3		QSPI0 output
	–	O4		Reserved
	–	O5		Reserved
	–	O6		Reserved
	COU60	O7		CCU61 output
D19	P20.12	I	MP / PU1 / VEXT	General-purpose input
	TIN68			GTM input
	MRST0A			QSPI0 input
	P20.12	O0		General-purpose output
	TOUT68	O1		GTM output
	–	O2		Reserved
	MRST0	O3		QSPI0 output
	MTSR0	O4		QSPI0 output
	–	O5		Reserved
	–	O6		Reserved
	COU61	O7		CCU61 output

Package and Pinning Definitions TC267x Pin Definition and Functions:

Table 2-44 Port 20 Functions (cont'd)

Pin	Symbol	Ctrl	Type	Function
D20	P20.13	I	MP / PU1 / VEXT	General-purpose input
	TIN69			GTM input
	SLSIOA			QSPI0 input
	P20.13	O0		General-purpose output
	TOUT69	O1		GTM output
	–	O2		Reserved
	SLSO02	O3		QSPI0 output
	SLSO12	O4		QSPI1 output
	SCLK0	O5		QSPI0 output
	–	O6		Reserved
	COU62	O7		CCU61 output
C20	P20.14	I	MP / PU1 / VEXT	General-purpose input
	TIN70			GTM input
	MTSR0A			QSPI0 input
	P20.14	O0		General-purpose output
	TOUT70	O1		GTM output
	–	O2		Reserved
	MTSR0	O3		QSPI0 output
	–	O4		Reserved
	–	O5		Reserved
	–	O6		Reserved
	–	O7		Reserved

Table 2-45 Port 21 Functions

Pin	Symbol	Ctrl	Type	Function
K17	P21.0	I	A2 / PU1 / VDDP3	General-purpose input
	TIN51			GTM input
	P21.0	O0		General-purpose output
	TOUT51	O1		GTM output
	–	O2		Reserved
	–	O3		Reserved
	–	O4		Reserved
	–	O5		Reserved
	ETHMDC	O6		ETH output
	–	O7		Reserved

Package and Pinning Definitions TC267x Pin Definition and Functions:

Table 2-45 Port 21 Functions (cont'd)

Pin	Symbol	Ctrl	Type	Function
J17	P21.1	I	A2 / PU1 / VDDP3	General-purpose input
	TIN52			GTM input
	ETHMDIOB			ETH input (Not for production purposes)
	P21.1	O0		General-purpose output
	TOUT52	O1		GTM output
	–	O2		Reserved
	–	O3		Reserved
	–	O4		Reserved
	–	O5		Reserved
	ETHMDIO	O6		ETH output (Not for production purposes)
–	O7	Reserved		
K19	P21.2	I	LVDSH_N/ PU1 / VDDP3	General-purpose input
	TIN53			GTM input
	MRST2CN			QSPI2 input (LVDS)
	MRST3FN			QSPI3 input (LVDS)
	EMGSTOPB			SCU input
	RXDN			HSCT input (LVDS)
	P21.2			O0
	TOUT53	O1		GTM output
	ASLSO3	O2		ASCLIN3 output
	–	O3		Reserved
	–	O4		Reserved
	ETHMDC	O5		ETH output
	–	O6		Reserved
	–	O7		Reserved

Package and Pinning Definitions TC267x Pin Definition and Functions:

Table 2-45 Port 21 Functions (cont'd)

Pin	Symbol	Ctrl	Type	Function
J19	P21.3	I	LVDSH_P/ PU1 / VDDP3	General-purpose input
	TIN54			GTM input
	MRST2CP			QSPI2 input (LVDS)
	MRST3FP			QSPI3 input (LVDS)
	RXDP			HSCT input (LVDS)
	P21.3	O0		General-purpose output
	TOUT54	O1		GTM output
	–	O2		Reserved
	–	O3		Reserved
	–	O4		Reserved
	–	O5		Reserved
	–	O6		Reserved
	–	O7		Reserved
ETHMDIOD	HWOUT	ETH input/output		
K20	P21.4	I	LVDSH_N/ PU1 / VDDP3	General-purpose input
	TIN55			GTM input
	P21.4	O0		General-purpose output
	TOUT55	O1		GTM output
	–	O2		Reserved
	–	O3		Reserved
	–	O4		Reserved
	–	O5		Reserved
	–	O6		Reserved
	–	O7		Reserved
	TXDN	O		HSCT output (LVDS)
J20	P21.5	I	LVDSH_P/ PU1 / VDDP3	General-purpose input
	TIN56			GTM input
	P21.5	O0		General-purpose output
	TOUT56	O1		GTM output
	ASCLK3	O2		ASCLIN3 output
	–	O3		Reserved
	–	O4		Reserved
	–	O5		Reserved
	–	O6		Reserved
	–	O7		Reserved
	TXDP	O		HSCT output (LVDS)

Package and Pinning Definitions TC267x Pin Definition and Functions:

Table 2-45 Port 21 Functions (cont'd)

Pin	Symbol	Ctrl	Type	Function
H17	P21.6	I	A2 / PU / VDDP3	General-purpose input
	TIN57			GTM input
	ARX3F			ASCLIN3 input
	TGI2			OCDS input
	TDI			OCDS (JTAG) input
	T5EUDA			GPT120 input
	P21.6			O0
	TOUT57	O1		GTM output
	ASLSO3	O2		ASCLIN3 output
	–	O3		Reserved
	–	O4		Reserved
	SYSCLK	O5		HSCT output
	–	O6		Reserved
	T3OUT	O7		GPT120 output
	TGO2	HWOUT		OCDS; ENx
		T		

Package and Pinning Definitions TC267x Pin Definition and Functions:

Table 2-45 Port 21 Functions (cont'd)

Pin	Symbol	Ctrl	Type	Function
H16	P21.7	I	A2 / PU / VDDP3	General-purpose input
	TIN58			GTM input
	DAP2			OCDS (3-Pin DAP) input In the 3-Pin DAP mode this pin is used as DAP2. In the 2-PIN DAP mode this pin is used as P21.7 and controlled by the related port control logic.
	TGI3			OCDS input
	ETHRXERB			ETH input
	T5INA			GPT120 input
	P21.7			O0
	TOUT58	O1	GTM output	
	ATX3	O2	ASCLIN3 output	
	ASCLK3	O3	ASCLIN3 output	
	–	O4	Reserved	
	–	O5	Reserved	
	–	O6	Reserved	
	T6OUT	O7	GPT120 output	
	TGO3	HWOU T	OCDS; ENx	
	TDO		OCDS (JTAG); ENx The JTAG TDO function is overlaid with P21.7 via a double bond. In JTAG mode this pin is used as TDO, after power-on reset it is HighZ.	
	DAP2		OCDS (DAP2); ENx In the 3-Pin DAP mode this pin is used as DAP2.	

Table 2-46 Port 22 Functions

Pin	Symbol	Ctrl	Type	Function
P20	P22.0	I	LVDSM_N / PU1 / VEXT	General-purpose input
	TIN47			GTM input
	MTSR3E			QSPI3 input
	P22.0	O0	General-purpose output	
	TOUT47	O1	GTM output	
	–	O2	Reserved	
	MTSR3	O3	QSPI3 output	
	SCLK3N	O4	QSPI3 output (LVDS)	
	FCLN1	O5	MSC1 output (LVDS)	
	FCLND1	O6	MSC1 output (LVDS)	
	–	O7	Reserved	

Package and Pinning Definitions TC267x Pin Definition and Functions:

Table 2-46 Port 22 Functions (cont'd)

Pin	Symbol	Ctrl	Type	Function
P19	P22.1	I	LVDSM_P / PU1 / VEXT	General-purpose input
	TIN48			GTM input
	MRST3E			QSPI3 input
	P22.1	O0		General-purpose output
	TOUT48	O1		GTM output
	–	O2		Reserved
	MRST3	O3		QSPI3 output
	SCLK3P	O4		QSPI3 output (LVDS)
	FCLP1	O5		MSC1 output (LVDS)
	–	O6		Reserved
	–	O7		Reserved
R20	P22.2	I	LVDSM_N / PU1 / VEXT	General-purpose input
	TIN49			GTM input
	SLSI3D			QSPI3 input
	P22.2	O0		General-purpose output
	TOUT49	O1		GTM output
	–	O2		Reserved
	SLSO312	O3		QSPI3 output
	MTRS3N	O4		QSPI3 output (LVDS)
	SON1	O5		MSC1 output (LVDS)
	SOND1	O6		MSC1 output (LVDS)
	–	O7		Reserved
R19	P22.3	I	LVDSM_P / PU1 / VEXT	General-purpose input
	TIN50			GTM input
	SCLK3E			QSPI3 input
	P22.3	O0		General-purpose output
	TOUT50	O1		GTM output
	–	O2		Reserved
	SCLK3	O3		QSPI3 output
	MTRS3P	O4		QSPI3 output (LVDS)
	SOP1	O5		MSC1 output (LVDS)
	–	O6		Reserved
	–	O7		Reserved

Package and Pinning Definitions TC267x Pin Definition and Functions:

Table 2-47 Port 23 Functions

Pin	Symbol	Ctrl	Type	Function
V20	P23.0	I	LP / PU1 / VEXT	General-purpose input
	TIN41			GTM input
	P23.0	O0		General-purpose output
	TOUT41	O1		GTM output
	–	O2		Reserved
	–	O3		Reserved
	–	O4		Reserved
	–	O5		Reserved
	–	O6		Reserved
	–	O7		Reserved
U19	P23.1	I	MP+ / PU1 / VEXT	General-purpose input
	TIN42			GTM input
	SDI10			MSC1 input
	P23.1	O0		General-purpose output
	TOUT42	O1		GTM output
	ARTS1	O2		ASCLIN1 output
	SLSO313	O3		QSPI3 output
	GTMCLK0	O4		GTM output
	–	O5		Reserved
	EXTCLK0	O6		SCU output
–	O7	Reserved		
U20	P23.2	I	LP / PU1 / VEXT	General-purpose input
	TIN43			GTM input
	P23.2	O0		General-purpose output
	TOUT43	O1		GTM output
	–	O2		Reserved
	–	O3		Reserved
	–	O4		Reserved
	–	O5		Reserved
	–	O6		Reserved
	–	O7		Reserved

Package and Pinning Definitions TC267x Pin Definition and Functions:

Table 2-47 Port 23 Functions (cont'd)

Pin	Symbol	Ctrl	Type	Function
T19	P23.3	I	LP / PU1 / VEXT	General-purpose input
	TIN44			GTM input
	INJ10			MSC1 input
	P23.3	O0		General-purpose output
	TOUT44	O1		GTM output
	–	O2		Reserved
	–	O3		Reserved
	–	O4		Reserved
	–	O5		Reserved
	–	O6		Reserved
	–	O7		Reserved
T20	P23.4	I	MP+ / PU1 / VEXT	General-purpose input
	TIN45			GTM input
	P23.4	O0		General-purpose output
	TOUT45	O1		GTM output
	–	O2		Reserved
	SLSO35	O3		QSPI3 output
	END12	O4		MSC1 output
	EN10	O5		MSC1 output
	–	O6		Reserved
	–	O7		Reserved
T17	P23.5	I	MP+ / PU1 / VEXT	General-purpose input
	TIN46			GTM input
	P23.5	O0		General-purpose output
	TOUT46	O1		GTM output
	–	O2		Reserved
	SLSO34	O3		QSPI3 output
	END13	O4		MSC1 output
	EN11	O5		MSC1 output
	–	O6		Reserved
	–	O7		Reserved

Package and Pinning Definitions TC267x Pin Definition and Functions:

Table 2-48 Port 32 Functions

Pin	Symbol	Ctrl	Type	Function
Y17	P32.0	I	LP / PX/ VEXT	General-purpose input
	TIN36			GTM input
	FDEST			PMU input
	VGATE1N			SMPS mode: analog output. External Pass Device gate control for EVR13
	P32.0	O0		General-purpose output
	TOUT36	O1		GTM output
	–	O2		Reserved
	–	O3		Reserved
	–	O4		Reserved
	–	O5		Reserved
	–	O6		Reserved
	–	O7		Reserved
Y18	P32.2	I	LP / PU1 / VEXT	General-purpose input
	TIN38			GTM input
	ARX3D			ASCLIN3 input
	RXDCAN3B			CAN node 3 input
	P32.2	O0		General-purpose output
	TOUT38	O1		GTM output
	ATX3	O2		ASCLIN3 output
	–	O3		Reserved
	–	O4		Reserved
	–	O5		Reserved
	DCDCSYNC	O6		SCU output
	–	O7		Reserved
Y19	P32.3	I	LP / PU1 / VEXT	General-purpose input
	TIN39			GTM input
	P32.3	O0		General-purpose output
	TOUT39	O1		GTM output
	ATX3	O2		ASCLIN3 output
	–	O3		Reserved
	ASCLK3	O4		ASCLIN3 output
	TXDCAN3	O5		CAN node 3 output
	–	O6		Reserved
	–	O7		Reserved

Package and Pinning Definitions TC267x Pin Definition and Functions:

Table 2-48 Port 32 Functions (cont'd)

Pin	Symbol	Ctrl	Type	Function
W18	P32.4	I	MP+ / PU1 / VEXT	General-purpose input
	TIN40			GTM input
	ACTS1B			ASCLIN1 input
	SDI12			MSC1 input
	P32.4	O0		General-purpose output
	TOUT40	O1		GTM output
	–	O2		Reserved
	END12	O3		MSC1 output
	GTMCLK1	O4		GTM output
	EN10	O5		MSC1 output
	EXTCLK1	O6		SCU output
	COU63	O7		CCU60 output

Table 2-49 Port 33 Functions

Pin	Symbol	Ctrl	Type	Function
W10	P33.0	I	LP / PU1 / VEXT	General-purpose input
	TIN22			GTM input
	DSITR0E			DSADC channel 0 input E
	P33.0	O0		General-purpose output
	TOUT22	O1		GTM output
	–	O2		Reserved
	–	O3		Reserved
	–	O4		Reserved
	–	O5		Reserved
	VADCG1BFL0	O6		VADC output
	–	O7		Reserved
Y10	P33.1	I	LP / PU1 / VEXT	General-purpose input
	TIN23			GTM input
	PSIRX0C			PSI5 input
	DSCIN2B			DSADC channel 2 input B
	P33.1	O0		General-purpose output
	TOUT23	O1		GTM output
	ASLSO3	O2		ASCLIN3 output
	–	O3		Reserved
	DSCOUT2	O4		DSADC channel 2 output
	VADCEMUX02	O5		VADC output
	VADCG1BFL1	O6		VADC output
	–	O7		Reserved

Package and Pinning Definitions TC267x Pin Definition and Functions:

Table 2-49 Port 33 Functions (cont'd)

Pin	Symbol	Ctrl	Type	Function
W11	P33.2	I	LP / PU1 / VEXT	General-purpose input
	TIN24			GTM input
	DSDIN2B			DSADC channel 2 input B
	DSITR2E			DSADC channel 2 input E
	P33.2	O0		General-purpose output
	TOUT24	O1		GTM output
	ASCLK3	O2		ASCLIN3 output
	–	O3		Reserved
	PSITX0	O4		PSI5 output
	VADCEMUX01	O5		VADC output
	VADCG1BFL2	O6		VADC output
	–	O7		Reserved
Y11	P33.3	I	LP / PU1 / VEXT	General-purpose input
	TIN25			GTM input
	PSIRX1C			PSI5 input
	P33.3	O0		General-purpose output
	TOUT25	O1		GTM output
	–	O2		Reserved
	–	O3		Reserved
	–	O4		Reserved
	VADCEMUX00	O5		VADC output
	VADCG1BFL3	O6		VADC output
	–	O7		Reserved
	W12	P33.4		I
TIN26		GTM input		
CTRAPC		CCU61 input		
DSITR0F		DSADC channel 0 input F		
P33.4		O0	General-purpose output	
TOUT26		O1	GTM output	
ARTS2		O2	ASCLIN2 output	
–		O3	Reserved	
PSITX1		O4	PSI5 output	
VADCEMUX12		O5	VADC output	
VADCG0BFL0		O6	VADC output	
–		O7	Reserved	

Package and Pinning Definitions TC267x Pin Definition and Functions:

Table 2-49 Port 33 Functions (cont'd)

Pin	Symbol	Ctrl	Type	Function
Y12	P33.5	I	LP / PU1 / VEXT	General-purpose input
	TIN27			GTM input
	ACTS2B			ASCLIN2 input
	PSIRX2C			PSI5 input
	PSISRXC			PSI5-S input
	SENT5C			SENT input
	CCPOS2C			CCU61 input
	T4EUDB			GPT120 input
	DSCIN0B			DSADC channel 0 input B
	P33.5			O0
	TOUT27	O1		GTM output
	SLSO07	O2		QSPI0 output
	SLSO17	O3		QSPI1 output
	DSCOUT0	O4		DSADC channel 0 output
	VADCEMUX11	O5		VADC output
	VADCG0BFL1	O6		VADC output
	–	O7		Reserved
	W13	P33.6		I
TIN28		GTM input		
SENT4C		SENT input		
CCPOS1C		CCU61 input		
T2EUDB		GPT120 input		
DSDIN0B		DSADC channel 0 input B		
DSITR2F		DSADC channel 2 input F		
P33.6		O0	General-purpose output	
TOUT28		O1	GTM output	
ASLSO2		O2	ASCLIN2 output	
–		O3	Reserved	
PSITX2		O4	PSI5 output	
VADCEMUX10		O5	VADC output	
VADCG0BFL2		O6	VADC output	
PSISTX		O7	PSI5-S output	

Package and Pinning Definitions TC267x Pin Definition and Functions:

Table 2-49 Port 33 Functions (cont'd)

Pin	Symbol	Ctrl	Type	Function
Y13	P33.7	I	LP / PU1 / VEXT	General-purpose input
	TIN29			GTM input
	RXDCAN0E			CAN node 0 input
	REQ8			SCU input
	CCPOS0C			CCU61 input
	T2INB			GPT120 input
	P33.7			O0
	TOUT29	O1		GTM output
	ASCLK2	O2		ASCLIN2 output
	SLSO37	O3		QSPI3 output
	–	O4		Reserved
	–	O5		Reserved
	VADCG0BFL3	O6		VADC output
	–	O7		Reserved
W14	P33.8	I	MP / HighZ/ VEXT	General-purpose input
	TIN30			GTM input
	ARX2E			ASCLIN2 input
	EMGSTOPA			SCU input
	P33.8	O0		General-purpose output
	TOUT30	O1		GTM output
	ATX2	O2		ASCLIN2 output
	SLSO32	O3		QSPI3 output
	–	O4		Reserved
	TXDCAN0	O5		CAN node 0 output
	–	O6		Reserved
	COU62	O7		CCU61 output
	SMUFSP	HWOUT		SMU
Y14	P33.9	I	LP / PU1 / VEXT	General-purpose input
	TIN31			GTM input
	HSIC3INA			QSPI3 input
	P33.9	O0		General-purpose output
	TOUT31	O1		GTM output
	ATX2	O2		ASCLIN2 output
	SLSO31	O3		QSPI3 output
	ASCLK2	O4		ASCLIN2 output
	–	O5		Reserved
	–	O6		Reserved
	CC62	O7		CCU61 output

Package and Pinning Definitions TC267x Pin Definition and Functions:

Table 2-49 Port 33 Functions (cont'd)

Pin	Symbol	Ctrl	Type	Function
W15	P33.10	I	MP / PU1 / VEXT	General-purpose input
	TIN32			GTM input
	SLSI3C			QSPI3 input
	HSIC3INB			QSPI3 input
	P33.10	O0		General-purpose output
	TOUT32	O1		GTM output
	SLSO16	O2		QSPI1 output
	SLSO311	O3		QSPI3 output
	ASLSO1	O4		ASCLIN1 output
	PSISCLK	O5		PSI5-S output
	–	O6		Reserved
	COUT61	O7		CCU61 output
Y15	P33.11	I	MP / PU1 / VEXT	General-purpose input
	TIN33			GTM input
	SCLK3D			QSPI3 input
	P33.11	O0		General-purpose output
	TOUT33	O1		GTM output
	ASCLK1	O2		ASCLIN1 output
	SCLK3	O3		QSPI3 output
	–	O4		Reserved
	–	O5		Reserved
	DSCGPWMN	O6		DSADC output
	CC61	O7		CCU61 output
W16	P33.12	I	MP / PU1 / VEXT	General-purpose input
	TIN34			GTM input
	MTR3D			QSPI3 input
	P33.12	O0		General-purpose output
	TOUT34	O1		GTM output
	ATX1	O2		ASCLIN1 output
	MTR3	O3		QSPI3 output
	ASCLK1	O4		ASCLIN1 output
	–	O5		Reserved
	DSCGPWMP	O6		DSADC output
	COUT60	O7		CCU61 output

Package and Pinning Definitions TC267x Pin Definition and Functions:

Table 2-49 Port 33 Functions (cont'd)

Pin	Symbol	Ctrl	Type	Function
Y16	P33.13	I	MP / PU1 / VEXT	General-purpose input
	TIN35			GTM input
	ARX1F			ASCLIN1 input
	MRST3D			QSPI3 input
	DSSGNB			DSADC input
	INJ11			MSC1 input
	P33.13			O0
	TOUT35	O1		GTM output
	ATX1	O2		ASCLIN1 output
	MRST3	O3		QSPI3 output
	SLSO26	O4		QSPI2 output
	–	O5		Reserved
	DCDCSYNC	O6		SCU output
	CC60	O7		CCU61 output

Table 2-50 Port 40 Functions

Pin	Symbol	Ctrl	Type	Function
W2	P40.0	I	S / HighZ / VDDM	General-purpose input
	VADCG1.8			VADC analog input channel 8 of group 1
	CCPOS0D			CCU60 input
	SENT0A			SENT input
W1	P40.1	I	S / HighZ / VDDM	General-purpose input
	VADCG1.9			VADC analog input channel 9 of group 1 (MD)
	CCPOS1B			CCU60 input
	SENT1A			SENT input
V2	P40.2	I	S / HighZ / VDDM	General-purpose input
	VADCG1.10			VADC analog input channel 10 of group 1 (MD)
	CCPOS1D			CCU60 input
	SENT2A			SENT input
V1	P40.3	I	S / HighZ / VDDM	General-purpose input
	VADCG1.11			VADC analog input channel 11 of group 1
	CCPOS2B			CCU60 input
	SENT3A			SENT input
N4	P40.6	I	S / HighZ / VDDM	General-purpose input
	VADCG2.4			VADC analog input channel 4 of group 2
	DS3PA			DSADC: positive analog input of channel 3, pin A
	CCPOS1B			CCU61 input
	SENT2D			SENT input

Package and Pinning Definitions TC267x Pin Definition and Functions:

Table 2-50 Port 40 Functions (cont'd)

Pin	Symbol	Ctrl	Type	Function
P2	P40.7	I	S / HighZ / VDDM	General-purpose input
	VADCG2.5			VADC analog input channel 5 of group 2
	DS3NA			DSADC: negative analog input channel of DSADC 3, pin A
	CCPOS1D			CCU61 input
	SENT3D			SENT input
N5	P40.8	I	S / HighZ / VDDM	General-purpose input
	VADCG2.6			VADC analog input channel 6 of group 2
	DS3PB			DSADC: positive analog input of channel 3, pin B
	CCPOS2B			CCU61 input
	SENT4A			SENT input
P1	P40.9	I	S / HighZ / VDDM	General-purpose input
	VADCG2.7			VADC analog input channel 7 of group 2
	DS3NB			DSADC: negative analog input channel of DSADC 3, pin B
	CCPOS2D			CCU61 input
	SENT5A			SENT input

Table 2-51 Analog Inputs

Pin	Symbol	Ctrl	Type	Function
T10	AN0	I	D / HighZ / VDDM	Analog input 0
	VADCG0.0			VADC analog input channel 0 of group 0
	DS0PB			DSADC: positive analog input of channel 0, pin B
U10	AN1	I	D / HighZ / VDDM	Analog input 1
	VADCG0.1			VADC analog input channel 1 of group 0 (MD)
	DS0NB			DSADC: negative analog input channel of DSADC 0, pin B
W9	AN2	I	D / HighZ / VDDM	Analog input 2
	VADCG0.2			VADC analog input channel 2 of group 0 (MD)
	DS0PA			DSADC: positive analog input of channel 0, pin A
U9	AN3	I	D / HighZ / VDDM	Analog input 3
	VADCG0.3			VADC analog input channel 3 of group 0
	DS0NA			DSADC: negative analog input channel of DSADC 0, pin A
T9	AN4	I	D / HighZ / VDDM	Analog input 4
	VADCG0.4			VADC analog input channel 4 of group 0
Y9	AN5	I	D / HighZ / VDDM	Analog input 5
	VADCG0.5			VADC analog input channel 5 of group 0

Package and Pinning Definitions TC267x Pin Definition and Functions:

Table 2-51 Analog Inputs (cont'd)

Pin	Symbol	Ctrl	Type	Function
T8	AN6	I	D / HighZ / VDDM	Analog input 6
	VADCG0.6			VADC analog input channel 6 of group 0
U8	AN7	I	D / HighZ / VDDM	Analog input 7
	VADCG0.7			VADC analog input channel 7 of group 0 (with pull down diagnostics)
W8	AN8	I	D / HighZ / VDDM	Analog input 8
	VADCG0.8			VADC analog input channel 8 of group 0
Y8	AN10	I	D / HighZ / VDDM	Analog input 10
	VADCG0.10			VADC analog input channel 10 of group 0 (MD)
W7	AN11	I	D / HighZ / VDDM	Analog input 11
	VADCG0.11			VADC analog input channel 11 of group 0
T7	AN12	I	D / HighZ / VDDM	Analog input 12
	VADCG0.12			VADC analog input channel 12 of group 0
W6	AN13	I	D / HighZ / VDDM	Analog input 13
	VADCG0.13			VADC analog input channel 13 of group 0
W5	AN16	I	D / HighZ / VDDM	Analog input 16
	VADCG1.0			VADC analog input channel 0 of group 1
U5	AN17	I	D / HighZ / VDDM	Analog input 17
	VADCG1.1			VADC analog input channel 1 of group 1 (MD)
W4	AN18	I	D / HighZ / VDDM	Analog input 18
	VADCG1.2			VADC analog input channel 2 of group 1 (MD)
W3	AN19	I	D / HighZ / VDDM	Analog input 19
	VADCG1.3			VADC analog input channel 3 of group 1 (with pull down diagnostics)
Y3	AN20	I	D / HighZ / VDDM	Analog input 20
	VADCG1.4			VADC analog input channel 4 of group 1
	DS2PA			DSADC: positive analog input of channel 2, pin A
Y2	AN21	I	D / HighZ / VDDM	Analog input 21
	VADCG1.5			VADC analog input channel 5 of group 1
	DS2NA			DSADC: negative analog input channel of DSADC 2, pin A
W2	AN24	I	S / HighZ / VDDM	Analog input 24
	VADCG1.8			VADC analog input channel 8 of group 1
	SENT0A			SENT input channel 0, pin A

Package and Pinning Definitions TC267x Pin Definition and Functions:

Table 2-51 Analog Inputs (cont'd)

Pin	Symbol	Ctrl	Type	Function
W1	AN25	I	S / HighZ / VDDM	Analog input 24
	VADCG1.9			VADC analog input channel 9 of group 1 (MD)
	SENT1A			SENT input channel 1, pin A
V2	AN26	I	S / HighZ / VDDM	Analog input 26
	VADCG1.10			VADC analog input channel 10 of group 1 (MD)
	SENT2A			SENT input channel 2, pin A
V1	AN27	I	S / HighZ / VDDM	Analog input 27
	VADCG1.11			VADC analog input channel 11 of group 1
	SENT3A			SENT input channel 3, pin A
U2	AN28	I	D / HighZ / VDDM	Analog input 28
	VADCG1.12			VADC analog input channel 12 of group 1
U1	AN29	I	D / HighZ / VDDM	Analog input 29
	VADCG1.13			VADC analog input channel 13 of group 1
P4	AN32	I	D / HighZ / VDDM	Analog input 32
	VADCG2.0			VADC analog input channel 0 of group 2
R1	AN33	I	D / HighZ / VDDM	Analog input 33
	VADCG2.1			VADC analog input channel 1 of group 2 (MD)
R2	AN35	I	D / HighZ / VDDM	Analog input 35
	VADCG2.3			VADC analog input channel 3 of group 2 (with pull down diagnostics)
N4	AN36	I	S / HighZ / VDDM	Analog input 34
	VADCG2.4			VADC analog input channel 4 of group 2
	DS3PA			DSADC: positive analog input of channel 3, pin A
	SENT2D			SENT input channel 2, pin D
P2	AN37	I	S / HighZ / VDDM	Analog input 37
	VADCG2.5			VADC analog input channel 5 of group 2
	DS3NA			DSADC: negative analog input channel of DSADC 3, pin A
	SENT3D			SENT input channel 3, pin D
N5	AN38	I	S / HighZ / VDDM	Analog input 38
	VADCG2.6			VADC analog input channel 6 of group 2
	DS3PB			DSADC: positive analog input of channel 3, pin B
	SENT4A			SENT input channel 4, pin A

Package and Pinning Definitions TC267x Pin Definition and Functions:

Table 2-51 Analog Inputs (cont'd)

Pin	Symbol	Ctrl	Type	Function
P1	AN39	I	S / HighZ / VDDM	Analog input 39
	VADCG2.7			VADC analog input channel 7 of group 2
	DS3NB			DSADC: negative analog input channel of DSADC 3, pin B
	SENT5A			SENT input channel 5, pin A
N1	AN44	I	D / HighZ / VDDM	Analog input 44
	VADCG2.10			VADC analog input channel 10 of group 2 (MD)
	DS3PC			DSADC: positive analog input of channel 3, pin C
N2	AN45	I	D / HighZ / VDDM	Analog input 45
	VADCG2.11			VADC analog input channel 11 of group 2
	DS3NC			DSADC: negative analog input channel of DSADC 3, pin C
M1	AN46	I	D / HighZ / VDDM	Analog input 46
	VADCG2.12			VADC analog input channel 12 of group 24
	DS3PD			DSADC: positive analog input of channel 3, pin D
M2	AN47	I	D / HighZ / VDDM	Analog input 47
	VADCG2.13			VADC analog input channel 13 of group 2
	DS3ND			DSADC: negative analog input channel of DSADC 3, pin D
M4	AN48	I	D / HighZ / VDDM	Analog input 48
	VADCG2.14			VADC analog input channel 14 of group 2
M5	AN49	I	D / HighZ / VDDM	Analog input 49
	VADCG2.15			VADC analog input channel 15 of group 2

Table 2-52 System I/O

Pin	Symbol	Ctrl	Type	Function
G17	PORST	I	PORST / PD / VEXT	Power On Reset Input Additional strong PD in case of power fail.
F16	ESR0	I/O	MP / OD / VEXT	External System Request Reset 0 Default configuration during and after reset is open-drain driver. The driver drives low during power-on reset. This is valid additionally after deactivation of PORST until the internal reset phase has finished. See also SCU chapter for details. Default after power-on can be different. See also SCU chapter 'Reset Control Unit' and SCU_IOCR register description.
	EVRWUP	I		EVR Wakeup Pin

Package and Pinning Definitions TC267x Pin Definition and Functions:

Table 2-52 System I/O (cont'd)

Pin	Symbol	Ctrl	Type	Function
G16	ESR1	I/O	MP / PU1 / VEXT	External System Request Reset 1 Default NMI function. See also SCU chapter 'Reset Control Unit' and SCU_IOCRR register description.
	EVRWUP	I		EVR Wakeup Pin
W17	VGATE1P	O	VGATE1P / - / VEXT	External Pass Device gate control for EVR13
K16	TMS	I	A2 / PD / VDDP3	JTAG Module State Machine Control Input
	DAP1	I/O		Device Access Port Line 1
L19	TRST	I	A2 / PD / VDDP3	JTAG Module Reset/Enable Input
J16	TCK	I	A2 / PD / VDDP3	JTAG Module Clock Input
	DAP0	I		Device Access Port Line 0
M20	XTAL1	I	XTAL1 / - / -	Main Oscillator/PLL/Clock Generator Input
M19	XTAL2	O	XTAL2 / - / -	Main Oscillator/PLL/Clock Generator Output

Table 2-53 Supply

Pin	Symbol	Ctrl	Type	Function
Y6	VAREF1	I	Vx	Positive Analog Reference Voltage 1
Y7	VAGND1	I	Vx	Negative Analog Reference Voltage 1
Y5	VDDM	I	Vx	ADC Analog Power Supply (3.3V / 5V)
G8, H7	VDD / VDDSB	I	Vx	Emulation Device: Emulation SRAM Standby Power Supply (1.3V) (Emulation Device only). Production Device: VDD (1.3V).
P8, P13, N7, N14, H14, G13	VDD	I	Vx	Digital Core Power Supply (1.3V)
N19	VDD	I	Vx	Digital Core Power Supply (1.3V). The supply pin inturn supplies the main XTAL Oscillator/PLL (1.3V) . A higher decoupling capacitor is therefore recommended to the VSS pin for better noise immunity.
A2, B3, V19, W20	VEXT	I	Vx	External Power Supply (5V / 3.3V)

Package and Pinning Definitions TC267x Pin Definition and Functions:

Table 2-53 Supply (cont'd)

Pin	Symbol	Ctrl	Type	Function
B18, A19	VDDP3	I	Vx	Digital Power Supply for Flash (3.3V). Can be also used as external 3.3V Power Supply for VFLEX.
N20	VDDP3	I	Vx	Digital Power Supply for Oscillator, LVDSH and A2 pads (3.3V). The supply pin inturn supplies the main XTAL Oscillator/PLL (3.3V) . A higher decoupling capacitor is therefore recommended to the VSS pin for better noise immunity.
E15, D16	VDDFL3	I	Vx	Flash Power Supply (3.3V)
D5	VFLEX	I	Vx	Digital Power Supply for Flex Port Pads (5V / 3.3V)
Y4	VSSM	I	Vx	Analog Ground for V _{DDM}
T11	VEVRSB	I	Vx	Standby Power Supply (3.3V/5V) for the Standby SRAM (CPU0.DSPR). If Standby mode is not used: To be handled like VEXT (3.3V/5V).
B2, D4, E5, L20, T16, U17, W19, Y20	VSS	I	Vx	Digital Ground
E16, D17, B19, A20	VSS	I	Vx	Digital Ground (outer balls)
P9, P12, N9, N10, N11, N12	VSS	I	Vx	Digital Ground (center balls)
M7, M8, M10, M11, M13, M14	VSS	I	Vx	Digital Ground (center balls)
L8, L9, L10, L11, L12, L13	VSS	I	Vx	Digital Ground (center balls)
K8, K9, K10, K11, K12, K13	VSS	I	Vx	Digital Ground (center balls)
J7, J8, J10, J11, J13, J14	VSS	I	Vx	Digital Ground (center balls)
H9, H10, H11, H12, G9, G10, G11, G12	VSS	I	Vx	Digital Ground (center balls)

Package and Pinning Definitions TC267x Pin Definition and Functions:

Table 2-53 Supply (cont'd)

Pin	Symbol	Ctrl	Type	Function
P10	VSS	I	Vx	Digital Ground (center balls) This ball is used in the Emulation Device as AGBT TX0N
P11	VSS	I	Vx	Digital Ground (center balls) This ball is used in the Emulation Device as AGBT TX0P
L7	VSS	I	Vx	Digital Ground (center balls) This ball is used in the Emulation Device as AGBT CLKN
K7	VSS	I	Vx	Digital Ground (center balls) This ball is used in the Emulation Device as AGBT CLKP
L14	VSS	I	Vx	Digital Ground (center balls) This ball is used in the Emulation Device as AGBT ERR
K14	NC / VDDPSB	I	NCVDDP SB	Emulation Device: Power Supply (3.3V) for DAP/JTAG pad group. Production Device: Not Connected.
U16, U15, U14, U13, U12, U11, U7, U6	NC	I	NC	Not Connected. These pins are reserved for future extensions and shall not be connected externally.
T15, T14, T13, T12, T6, T5, T4, T2, T1	NC	I	NC	Not Connected. These pins are reserved for future extensions and shall not be connected externally.
E12, E11, E10, E9, E8, E7, E6, E4, D10, D8, D7, D6	NC	I	NC	Not Connected. These pins are reserved for future extensions and shall not be connected externally.
R5, R4, P5, L5, L4, J5, H5, H4, G5, G4, F5, F4	NC	I	NC	Not Connected. These pins are reserved for future extensions and shall not be connected externally.

Package and Pinning Definitions TC267x Pin Definition and Functions:

Table 2-53 Supply (cont'd)

Pin	Symbol	Ctrl	Type	Function
R17, R16, P17, P16, N17, N16, M17, M16, L17, L16	NC	I	NC	Not Connected. These pins are reserved for future extensions and shall not be connected externally.
A1, Y1, U4	NC	I	NC1	Not Connected. These pins are not connected on package level and will not be used for future extensions.

Legend:

Column "Ctrl.":

 I = Input (for GPIO port Lines with IOCR bit field Selection PCx = 0XXX_B)

O = Output

 O0 = Output with IOCR bit field selection PCx = 1X000_B

 O1 = Output with IOCR bit field selection PCx = 1X001_B (ALT1)

 O2 = Output with IOCR bit field selection PCx = 1X010_B (ALT2)

 O3 = Output with IOCR bit field selection PCx = 1X011_B (ALT3)

 O4 = Output with IOCR bit field selection PCx = 1X100_B (ALT4)

 O5 = Output with IOCR bit field selection PCx = 1X101_B (ALT5)

 O6 = Output with IOCR bit field selection PCx = 1X110_B (ALT6)

 O7 = Output with IOCR bit field selection PCx = 1X111_B (ALT7)

Column "Type":

LP = Pad class LP (5V/3.3V, LVTTTL)

MP = Pad class MP (5V/3.3V, LVTTTL)

MP+ = Pad class MP (5V/3.3V, LVTTTL)

A2 = Pad class A2 (3.3V, LVTTTL)

LVDSM = Pad class LVDSM (LVDS/CMOS 5V/3.3V)

LVDSH = Pad class LVDSH (LVDS/CMOS 3.3V)

S = Pad class S (ADC overlaid with General Purpose Input)

D = Pad class D (ADC)

 PU = with pull-up device connected during reset ($\overline{\text{PORST}} = 0$)

 PU1 = with pull-up device connected during reset ($\overline{\text{PORST}} = 0$)^{1) 2) 3)}

 PD = with pull-down device connected during reset ($\overline{\text{PORST}} = 0$)

 PD1 = with pull-down device connected during reset ($\overline{\text{PORST}} = 0$)^{1) 2) 3)}

PX = Behavior depends on usage: PD in EVR13 SMPS Mode and PU1 in GPIO Mode

 OD = open drain during reset ($\overline{\text{PORST}} = 0$)

 HighZ = tri-state during reset ($\overline{\text{PORST}} = 0$)

PORST = PORST input pad

XTAL1 = XTAL1 input pad

XTAL2 = XTAL2 input pad

1) The default state of GPIOs (Px.y) during and after $\overline{\text{PORST}}$ active is controlled via HWCFG[6] (P14.4). HWCFG[6] has a weak internal pull-up active at start-up if the pin is left unconnected. See also User's Manual, "Introduction Chapter", "General Purpose I/O Ports and Peripheral I/O Lines", Figure: "Default state of port pins during and after reset".

2) If HWCFG[6] is left unconnected or is externally pulled high, weak internal pull-ups (PU1) / pull-downs (PD1) are active during and after reset.

3) If HWCFG[6] is connected to ground, the PD1/PU1 pins are predominantly in HighZ during and after reset.

Package and Pinning Definitions TC267x Pin Definition and Functions:

VGATE1P = VGATE1P

VGATE3P = VGATE3P

Vx = Supply

NC = These pins are reserved for future extensions and shall not be connected externally

NC1 = These pins are not connected on package level and will not be used for future extensions

NCVDDPSB = This pin has a different functionality in an Production Device and an Emulation Device. For details pls. see Pin/Ball description of this pin.

NCVDDSB = This pin has a different functionality in an Production Device and an Emulation Device. For details pls. see Pin/Ball description of this pin.

2.3.2 Emergency Stop Function

The Emergency Stop function can be used to force GPIOs (General Purpose Inputs/Outputs) via an external input signal (EMGSTOPA or EMGSTOPB) into a defined state:

- Input state and
- PU or High-Z depending on HWCFG[6] level latched during $\overline{\text{PORST}}$ active

Control of the Emergency Stop function:

- The Emergency Stop function can be enabled/disabled in the SCU (see chapter "SCU", "Emergency Stop Control")
- The Emergency Stop input signal, EMGSTOPA (P33.8) / EMGSTOPB (P21.2), can be selected in the SCU (see chapter "SCU", "Emergency Stop Control")
- On port level, each GPIO can be enabled/disabled for the Emergency Stop function via the Px_ESR (Port x Emergency Stop) registers in the port control logic (see chapter "General Purpose I/O Ports and Peripheral I/O Lines", "Emergency Stop Register").

The Emergency Stop function is available for all GPIO Ports with the following exceptions:

- Not available for P20.2 (General Purpose Input/GPI only, overlaid with Testmode)
- Not available for P40.x (analoge input ANx overlaid with GPI)
- Not available for P32.0 EVR13 SMPS mode.
- Not available for dedicated I/O without General Purpose Output function (e.g ESRx, TMS, TCK)

The Emergency Stop function can be overruled on the following GPIO Ports:

- P00.x and P02.x: Emergency Stop can be overruled by the 8-Bit Standby Controller (SBR), if implemented. Overruling can be disabled via the control registers P00_SCR / P02_SCR (see chapter "General Purpose I/O Ports and Peripheral I/O Lines", P00 / P01)
- P00.x: Emergency Stop can be overruled by the VADC. Overruling can be disabled via the control register P00_SCR (see chapter "General Purpose I/O Ports and Peripheral I/O Lines", P00)
- P14.0 and P14.1: Emergency Stop can be overruled in the DXCPL mode (DAP over can physical layer mode). No Overruling in the DXCM (Debug over can message) mode
- P21.6: Emergency Stop can be overruled in JTAG mode if this pin is used as TDI
- P21.7: Emergency Stop can be overruled in JTAG or Three Pin DAP mode
- P20.0: Emergency Stop can be overruled in JTAG mode if this GPIO is used as TDI

2.3.3 Pull-Up/Pull-Down Reset Behavior of the Pins

Package and Pinning Definitions TC260 Bare Die Pad Definition:

Table 2-54 List of Pull-Up/Pull-Down Reset Behavior of the Pins

Pins	$\overline{\text{PORST}} = 0$	$\overline{\text{PORST}} = 1$
all GPIOs	Pull-up if HWCFG[6] = 1 or High-Z if HWCFG[6] = 0	
$\overline{\text{TDI}}$, $\overline{\text{TESTMODE}}$	Pull-up	
$\overline{\text{PORST}}^{1)}$	Pull-down with I_{PORST} relevant	Pull-down with I_{PDLI} relevant
$\overline{\text{TRST}}$, TCK, TMS	Pull-down	
ESR0	The open-drain driver is used to drive low. ²⁾	Pull-up ³⁾
ESR1	Pull-up ³⁾	
TDO	Pull-up	High-Z/Pull-up ⁴⁾

- 1) Pull-down with I_{PORST} relevant is always activated when a primary supply monitor detects a violation.
- 2) Valid additionally after deactivation of $\overline{\text{PORST}}$ until the internal reset phase has finished. See the SCU chapter for details.
- 3) See the SCU_IOCR register description.
- 4) Depends on JTAG/DAP selection with $\overline{\text{TRST}}$.

In case of leakage test ($\overline{\text{PORST}} = 0$ and $\overline{\text{TESTMODE}} = 0$), the pull-down of the $\overline{\text{TRST}}$ pin is switched off. In case of an user application ($\overline{\text{TESTMODE}} = 1$), the pull-down of the $\overline{\text{TRST}}$ is always switched on.

2.4 TC260 Bare Die Pad Definition:

List of the TC260x Bare Die Pads describes the pads of the TC260 bare die. It describes also the mapping of VADC / DS-ADC channels to the analog inputs (ANx) and the mapping of Port functions to the pads.

The detailed description of the port functions (Px.y) can be found in the User's Manual chapter "General Purpose I/O Ports and Peripheral I/O Lines (Ports)".

Package and Pinning Definitions TC260 Bare Die Pad Definition:

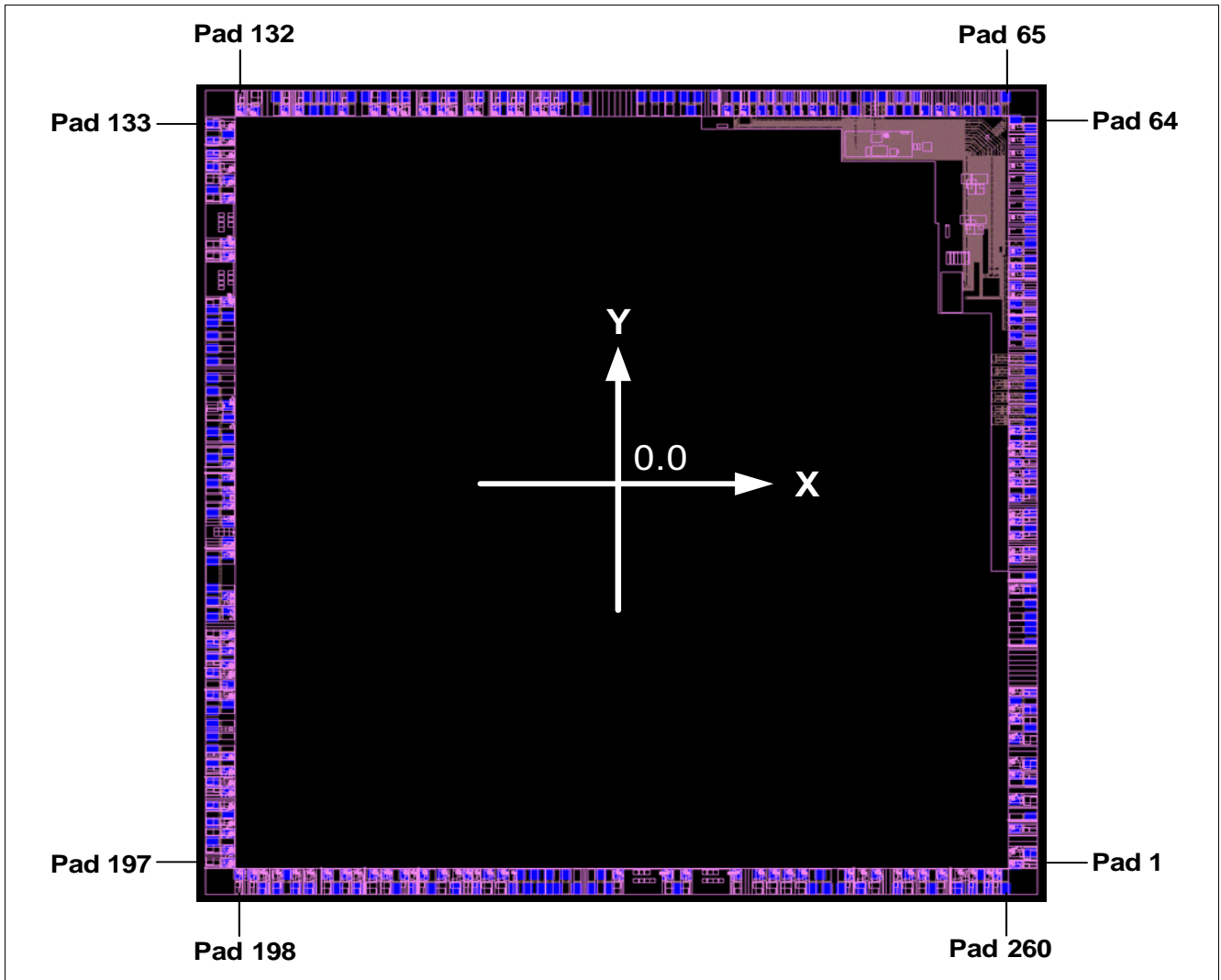

Figure 2-4 TC 260 / 264 / 265 / 267 Logic Symbol for the Bare Die.

Table 2-55 List of the TC260x Bare Die Pads

Number	Pad Name	Pad Type	X	Y	Comment
1	P10.8	LP / PU1 / VEXT	2756500	-2951000	GPIO
2	P02.0	MP+ / PU1 / VEXT	2865000	-2861000	GPIO
3	P02.1	LP / PU1 / VEXT	2756500	-2671000	GPIO
4	VSS	Vx	2865000	-2581000	Must be bonded to VSS
5	P02.2	MP+ / PU1 / VEXT	2756500	-2446000	GPIO
6	VEXT	Vx	2865000	-2311000	Must be bonded to VEXT
7	P02.3	LP / PU1 / VEXT	2756500	-2256000	GPIO
8	P02.4	MP+ / PU1 / VEXT	2865000	-2166000	GPIO
9	P02.5	MP+ / PU1 / VEXT	2756500	-1976000	GPIO

Package and Pinning Definitions TC260 Bare Die Pad Definition:

Table 2-55 List of the TC260x Bare Die Pads

Number	Pad Name	Pad Type	X	Y	Comment
10	VSS	Vx	2865000	-1891000	Must be bonded to VSS
11	P02.6	MP / PU1 / VEXT	2756500	-1826000	GPIO
12	P02.7	MP / PU1 / VEXT	2865000	-1746000	GPIO
13	VEXT	Vx	2756500	-1681000	Must be bonded to VEXT
14	P02.8	LP / PU1 / VEXT	2865000	-1616000	GPIO
15	VDD	Vx	2865000	-1229000	Must be bonded to VDD
16	VSS	Vx	2865000	-1099000	Must be bonded to VSS. Double Pad (Elephant Pad), shared with Pad Nr. 17.
17	VSS	Vx	2865000	-1059000	Must be bonded to VSS. Double Pad (Elephant Pad), shared with Pad Nr. 16.
18	VDD	Vx	2865000	-929000	Must be bonded to VDD
19	P00.0	MP / PU1 / VEXT	2865000	-814000	GPIO
20	VSS	Vx	2865000	-714000	Must be bonded to VSS
21	P00.1	LP / PU1 / VEXT	2756500	-443000	GPIO
22	P00.2	LP / PU1 / VEXT	2865000	-383000	GPIO
23	P00.3	LP / PU1 / VEXT	2756500	-263000	GPIO
24	VSS	Vx	2865000	-208000	Must be bonded to VSS
25	P00.4	LP / PU1 / VEXT	2756500	-153000	GPIO
26	P00.5	LP / PU1 / VEXT	2865000	-93000	GPIO
27	P00.6	LP / PU1 / VEXT	2756500	27000	GPIO
28	VEXT	Vx	2865000	82000	Must be bonded to VEXT
29	P00.7	LP / PU1 / VEXT	2756500	147000	GPIO
30	P00.8	LP / PU1 / VEXT	2865000	217000	GPIO
31	P00.9	LP / PU1 / VEXT	2756500	297000	GPIO
32	P00.10	LP / PU1 / VEXT	2865000	377000	GPIO
33	P00.11	LP / PU1 / VEXT	2756500	442000	GPIO
34	VSS	Vx	2865000	497000	Must be bonded to VSS
35	P00.12	LP / PU1 / VEXT	2756500	552000	GPIO
36	VDD	Vx	2865000	607000	Must be bonded to VDD
37	VSS	Vx	2865000	707000	Must be bonded to VSS
38	VSS	Vx	2865000	807000	Must be bonded to VSS
39	VDD	Vx	2865000	907000	Must be bonded to VDD
40	VEXT	Vx	2865000	1007000	Must be bonded to VEXT
41	VSS	Vx	2865000	1107000	Must be bonded to VSS
42	AN49 (VADCG2.15)	D	2865000	1227000	Analog input
43	AN48 (VADCG2.14)	D	2756500	1287000	Analog input

Package and Pinning Definitions TC260 Bare Die Pad Definition:

Table 2-55 List of the TC260x Bare Die Pads

Number	Pad Name	Pad Type	X	Y	Comment
44	VDDM	Vx	2865000	1347000	ADC external supply
45	AN47 (VADCG2.13 / DS3.N3)	D	2756500	1407000	Analog input, GPI (SENT, CCU6)
46	AN46 (VADCG2.12 / DS3.P3)	D	2865000	1470000	Analog input, GPI (SENT, CCU6)
47	AN45 (VADCG2.11 / DS3.N2)	D	2756500	1530000	Analog input, GPI (SENT, CCU6)
48	AN44 (VADCG2.10 / DS3.P2)	D	2865000	1605000	Analog input, GPI (SENT, CCU6)
49	AN39 (VADCG2.7 / DS3.N1), P40.9 (SENT5A)	S	2756500	1665000	Analog input, GPI (SENT, CCU6)
50	AN38 (VADCG2.6 / DS3.P1), P40.8 (SENT4A)	S	2865000	1754000	Analog input, GPI (SENT, CCU6)
51	AN37 (VADCG2.5 / DS3.N0), P40.7 (SENT3D)	S	2756500	1816000	Analog input, GPI (SENT, CCU6)
52	VDDM	Vx	2865000	1876000	ADC external supply
53	AN36 (VADCG2.4 / DS3.P0), P40.6 (SENT2D)	S	2756500	1936000	Analog input, GPI (SENT, CCU6)
54	VSSM	Vx	2865000	1996000	ADC ground
55	AN35 (VADCG2.3)	D	2865000	2096000	Analog input (mtm) (with pull down diagnostics)
56	AN33 (VADCG2.1)	D	2865000	2196000	Analog input
57	AN32 (VADCG2.0)	D	2865000	2296000	Analog input
58	AN29 (VADCG1.13)	D	2865000	2396000	Analog input
59	AN28 (VADCG1.12)	D	2865000	2496000	Analog input
60	AN27 (VADCG1.11), P40.3 (SENT3A)	S	2865000	2596000	Analog input, GPI (SENT, CCU6)
61	AN26 (VADCG1.10), P40.2 (SENT2A)	S	2865000	2696000	Analog input, GPI (SENT, CCU6)
62	AN25 (VADCG1.9), P40.1 (SENT1A)	S	2865000	2796000	Analog input, GPI (SENT, CCU6)
63	AN24 (VADCG1.8), P40.0 (SENT0A)	S	2865000	2896000	Analog input, GPI (SENT, CCU6)
64	VDDM	Vx	2756500	2956000	ADC external supply
65	VSSM	Vx	2685000	3136000	ADC ground

Package and Pinning Definitions TC260 Bare Die Pad Definition:

Table 2-55 List of the TC260x Bare Die Pads

Number	Pad Name	Pad Type	X	Y	Comment
66	AN21 (VADCG1.5 / DS2NA)	D	2625000	3027500	Analog input
67	AN20 (VADCG1.4 / DS2PA)	D	2525000	3027500	Analog input
68	AN19 (VADCG1.3)	D	2425000	3027500	Analog input (with pull down diagnostics)
69	AN18 (VADCG1.2)	D	2325000	3027500	Analog input
70	AN17 (VADCG1.1)	D	2225000	3027500	Analog input
71	AN16 (VADCG1.0)	D	2165000	3136000	Analog input
72	VAGND1	Vx	2105000	3027500	Negative Analog Reference Voltage 1
73	VAGND0	Vx	2045000	3136000	Negative Analog Reference Voltage 0
74	VAREF1	Vx	1985000	3027500	Positive Analog Reference Voltage 1
75	VAREF0	Vx	1925000	3136000	Positive Analog Reference Voltage 0
76	VSSM	Vx	1865000	3027500	ADC ground
77	VSSMREF	Vx	1805000	3136000	ADC reference ground.
78	VSSM_DS	Vx	1745000	3027500	DS-ADC ground. Must be bonded with VSSM.
79	VDDM	Vx	1675000	3136000	ADC external supply
80	VDDM_DS	Vx	1585000	3027500	DS-ADC external supply. Must be bonded with VDDM.
81	AN13 (VADCG0.13)	D	1525000	3136000	Analog input
82	AN12 (VADCG0.12)	D	1465000	3027500	Analog input
83	AN11 (VADCG0.11)	D	1405000	3136000	Analog input
84	AN10 (VADCG0.10)	D	1345000	3027500	Analog input
85	AN8 (VADCG0.8)	D	1285000	3136000	Analog input
86	AN7 (VADCG0.7)	D	1225000	3027500	Analog input (with pull down diagnostics)
87	AN6 (VADCG0.6)	D	1165000	3136000	Analog input
88	AN5 (VADCG0.5)	D	1105000	3027500	Analog input
89	AN4 (VADCG0.4)	D	1043000	3136000	Analog input
90	AN3 (VADCG0.3 / DS0NA)	D	983000	3027500	Analog input
91	VSSM	Vx	923000	3136000	ADC ground

Package and Pinning Definitions TC260 Bare Die Pad Definition:

Table 2-55 List of the TC260x Bare Die Pads

Number	Pad Name	Pad Type	X	Y	Comment
92	AN2 (VADCG0.2 / DS0PA)	D	863000	3027500	Analog input
93	VDDM	Vx	803000	3136000	ADC external supply
94	AN1 (VADCG0.1 / DS0NB)	D	743000	3027500	Analog input
95	AN0 (VADCG0.0 / DS0PB)	D	656000	3136000	Analog input
96	VSS	Vx	536000	3136000	Must be bonded to VSS
97	VEXT	Vx	486000	3027500	Must be bonded to VEXT
98	VDD	Vx	436000	3136000	Must be bonded to VDD
99	VSS	Vx	306000	3136000	Must be bonded to VSS. Double Pad (Elephant Pad), shared with Pad Nr. 98.
100	VSS	Vx	266000	3136000	Must be bonded to VSS. Double Pad (Elephant Pad), shared with Pad Nr. 97.
101	VDD	Vx	136000	3136000	Must be bonded to VDD
102	VEXT	Vx	-250000	3027500	Must be bonded to VEXT
103	VEXT	Vx	-315000	3136000	Must be bonded to VEXT
104	EVR_OFF	Vx	-415000	3136000	Must be bonded to VSS
105	P33.0	LP / PU1 / VEXT	-470000	3027500	GPIO
106	P33.1	LP / PU1 / VEXT	-540000	3136000	GPIO
107	P33.2	LP / PU1 / VEXT	-600000	3027500	GPIO
108	P33.3	LP / PU1 / VEXT	-710000	3136000	GPIO
109	P33.4	LP / PU1 / VEXT	-770000	3027500	GPIO
110	VSS	Vx	-825000	3136000	Must be bonded to VSS
111	P33.5	LP / PU1 / VEXT	-880000	3027500	GPIO
112	P33.6	LP / PU1 / VEXT	-1000000	3136000	GPIO
113	P33.7	LP / PU1 / VEXT	-1060000	3027500	GPIO
114	P33.8	MP / HighZ / VEXT	-1190000	3136000	GPIO
115	P33.9	LP / PU1 / VEXT	-1260000	3027500	GPIO
116	VEXT	Vx	-1315000	3136000	Must be bonded to VEXT
117	P33.10	MP / PU1 / VEXT	-1380000	3027500	GPIO
118	P33.11	MP / PU1 / VEXT	-1520000	3136000	GPIO
119	P33.12	MP / PU1 / VEXT	-1600000	3027500	GPIO
120	VSS	Vx	-1665000	3136000	Must be bonded to VSS
121	P33.13	MP / PU1 / VEXT	-1730000	3027500	GPIO
122	VSS	Vx	-1795000	3136000	Must be bonded to VSS
123	VDD	Vx	-1895000	3136000	Must be bonded to VDD

Package and Pinning Definitions TC260 Bare Die Pad Definition:

Table 2-55 List of the TC260x Bare Die Pads

Number	Pad Name	Pad Type	X	Y	Comment
124	P32.0	LP / EVR13 SMPS -> PD, GPIO -> PU1 / VEXT	-1950000	3027500	GPIO
125	VGATE1N (SMPS)	VGATE1N	-2005000	3136000	Must be bonded to VSS if EVR13 SMPS is not used. Must be bonded to NMOS gate if EVR13 SMPS is used.
126	VGATE1P (SMPS)	VGATE1P	-2055000	3027500	Must be bonded to VEXT if EVR13 SMPS is not used. Must be bonded to PMOS gate if EVR13 SMPS is used.
127	VGATE3P (LDO)	VGATE3P	-2105000	3136000	Must be bonded to VSS
128	VGATE1P (LDO)	VGATE1P	-2155000	3027500	Must be bonded to VSS if no external P channel MOSFET is used for EVR13 LDO generation. Must be bonded to external P channel MOSFET if external LDO pass device is used.
129	VEXT	Vx	-2205000	3136000	Must be bonded to VEXT
130	P32.2	LP / PU1 / VEXT	-2260000	3027500	GPIO
131	P32.3	LP / PU1 / VEXT	-2360000	3027500	GPIO
132	VSS	Vx	-2415000	3136000	Must be bonded to VSS
133	P32.4	MP+ / PU1 / VEXT	-2570000	3027500	GPIO
134	P23.0	LP / PU1 / VEXT	-2670000	3027500	GPIO
135	P23.1	MP+ / PU1 / VEXT	-2865000	2921000	GPIO
136	VEXT	Vx	-2756500	2846000	Must be bonded to VEXT
137	P23.2	LP / PU1 / VEXT	-2865000	2791000	GPIO
138	P23.3	LP / PU1 / VEXT	-2865000	2689000	GPIO
139	P23.4	MP+ / PU1 / VEXT	-2865000	2589000	GPIO
140	P23.5	MP+ / PU1 / VEXT	-2756500	2489000	GPIO
141	VSS	Vx	-2865000	2414000	Must be bonded to VSS
142	P22.0	MP / LVDSM_N / PU1 / VEXT	-2756500	2349000	GPIO

Package and Pinning Definitions TC260 Bare Die Pad Definition:

Table 2-55 List of the TC260x Bare Die Pads

Number	Pad Name	Pad Type	X	Y	Comment
143	P22.1	MP / LVDS_P / PU1 / VEXT	-2756500	1999000	GPIO
144	P22.2	MP / LVDSM_N / PU1 / VEXT	-2756500	1899000	GPIO
145	P22.3	MP / LVDS_P / PU1 / VEXT	-2756500	1549000	GPIO
146	VEXT	Vx	-2865000	1484000	Must be bonded to VEXT
147	VEXT	Vx	-2756500	1434000	Must be bonded to VEXT
148	VDD	Vx	-2865000	1384000	Must be bonded to VDD
149	VSS	Vx	-2865000	1284000	Must be bonded to VSS
150	VSS	Vx	-2865000	1184000	Must be bonded to VSS
151	VDD	Vx	-2865000	1084000	Must be bonded to VDD
152	VDDOSC	Vx	-2865000	818000	Must be bonded to VDD
153	VSSOSC	Vx	-2865000	718000	Must be bonded to VSS
154	XTAL1	XTAL1	-2756500	610500	Main Oscillator/PLL/Clock Generator Input. Must be bonded to external quartz or resonator.
155	XTAL2	XTAL2	-2756500	510500	Main Oscillator/PLL/Clock Generator Input. Must be bonded to external quartz or resonator.
156	VSSOSC	Vx	-2865000	403000	Must be bonded to VSS
157	VDDOSC3	Vx	-2756500	353000	Must be bonded to VDDP3
158	VDDP3	Vx	-2756500	253000	Must be bonded to VDDP3
159	VSSP	Vx	-2865000	203000	Must be bonded to VSS
160	P21.0	A2 / PU1 / VDDP3	-2756500	153000	GPIO
161	P21.1	A2 / PU1 / VDDP3	-2756500	53000	GPIO
162	VSSP	Vx	-2865000	3000	Must be bonded to VSS
163	P21.2	LVDSH_N / PU1 / VDDP3	-2756500	-59500	GPIO
164	P21.3	LVDSH_P / PU1 / VDDP3	-2756500	-159500	GPIO
165	VDDP3	Vx	-2865000	-222000	Must be bonded to VDDP3
166	P21.4	LVDSH_N / PU1 / VDDP3	-2756500	-296500	GPIO
167	P21.5	LVDSH_P / PU1 / VDDP3	-2756500	-447500	GPIO
168	P21.6	A2 / PU / VDDP3	-2756500	-547000	GPIO, TDI
169	VDDP3	Vx	-2865000	-597000	Must be bonded to VDDP3
170	VSSP	Vx	-2865000	-812000	Must be bonded to VSS

Package and Pinning Definitions TC260 Bare Die Pad Definition:

Table 2-55 List of the TC260x Bare Die Pads

Number	Pad Name	Pad Type	X	Y	Comment
171	TMS /DAP1	A2 / PD / VDDP3	-2756500	-862000	JTAG Module TMS Input / Device Access Port Line 1
172	P21.7	A2 / PU / VDDP3	-2865000	-912000	GPIO, TDO
173	TRST (N)	A2 / PD / VDDP3	-2756500	-982000	JTAG Module Reset/Enable Input
174	TCK /DAP0	A2 / PD / VDDP3	-2865000	-1032000	JTAG Module Clock Input / Device Access Port Line 0
175	P20.0	MP / PU1 / VEXT	-2756500	-1167000	GPIO
176	P20.1	LP / PU1 / VEXT	-2865000	-1237000	GPIO
177	P20.2	LP / PU / VEXT	-2756500	-1292000	Testmode pin must be bonded
178	VSS	Vx	-2865000	-1342000	Must be bonded to VSS
179	P20.3	LP / PU1 / VEXT	-2756500	-1397000	GPIO
180	ESR1 (N) /EVRWUP	MP / PU1	-2865000	-1472000	External System Request Reset 1. Default NMI function. / EVR Wakeup Pin
181	PORST (N)	PORST / PD / VEXT	-2756500	-1554500	Power On Reset Input. Additional strong PD in case of power fail.
182	ESR0 (N) /EVRWUP	MP / OD	-2865000	-1642000	External System Request Reset 0. Default configuration during and after reset is open-drain driver. The driver drives low during power-on reset. /EVR Wakeup Pin
183	VEXT	Vx	-2756500	-1707000	Must be bonded to VEXT
184	VDD	Vx	-2865000	-1757000	Must be bonded to VDD
185	VSS	Vx	-2865000	-1887000	Must be bonded to VSS. Double Pad (Elephant Pad), shared with Pad Nr. 184.
186	VSS	Vx	-2865000	-1927000	Must be bonded to VSS. Double Pad (Elephant Pad), shared with Pad Nr. 183.
187	VDD	Vx	-2865000	-2057000	Must be bonded to VDD
188	P20.6	LP / PU1 / VEXT	-2756500	-2112000	GPIO
189	VSS	Vx	-2865000	-2167000	Must be bonded to VSS
190	P20.7	LP / PU1 / VEXT	-2756500	-2222000	GPIO
191	P20.8	MP / PU1 / VEXT	-2865000	-2317000	GPIO
192	P20.9	LP / PU1 / VEXT	-2756500	-2387000	GPIO
193	P20.10	MP / PU1 / VEXT	-2865000	-2497000	GPIO
194	VEXT	Vx	-2756500	-2562000	Must be bonded to VEXT

Package and Pinning Definitions TC260 Bare Die Pad Definition:

Table 2-55 List of the TC260x Bare Die Pads

Number	Pad Name	Pad Type	X	Y	Comment
195	P20.11	MP / PU1 / VEXT	-2865000	-2627000	GPIO
196	P20.12	MP / PU1 / VEXT	-2756500	-2707000	GPIO
197	VSS	Vx	-2865000	-2772000	Must be bonded to VSS
198	P20.13	MP / PU1 / VEXT	-2756500	-2837000	GPIO
199	P20.14	MP / PU1 / VEXT	-2756500	-2937000	GPIO
200	P15.0	LP / PU1 / VEXT	-2680000	-3027500	GPIO
201	P15.1	LP / PU1 / VEXT	-2580000	-3027500	GPIO
202	P15.2	MP / PU1 / VEXT	-2510000	-3136000	GPIO
203	P15.3	MP / PU1 / VEXT	-2410000	-3136000	GPIO
204	VEXT	Vx	-2345000	-3027500	Must be bonded to VEXT
205	P15.4	MP / PU1 / VEXT	-2280000	-3136000	GPIO
206	P15.5	MP / PU1 / VEXT	-2180000	-3136000	GPIO
207	P15.6	MP / PU1 / VEXT	-2059000	-3027500	GPIO
208	VSS	Vx	-1994000	-3136000	Must be bonded to VSS
209	P15.7	MP / PU1 / VEXT	-1929000	-3027500	GPIO
210	P15.8	MP / PU1 / VEXT	-1849000	-3136000	GPIO
211	P14.0	MP+ / PU1 / VEXT	-1741000	-3027500	GPIO
212	P14.1	MP / PU1 / VEXT	-1641000	-3027500	GPIO
213	VEXT	Vx	-1576000	-3136000	Must be bonded to VEXT
214	P14.2	LP / PU1 / VEXT	-1521000	-3027500	Must be bonded to VEXT if EVR13 active. Must be bonded to VSS if EVR13 inactive.
215	P14.3	LP / PU1 / VEXT	-1461000	-3136000	GPIO
216	P14.4	LP / PU1 / VEXT	-1386000	-3027500	GPIO
217	VSS	Vx	-1331000	-3136000	Must be bonded to VSS
218	P14.5	MP+ / PU1 / VEXT	-1256000	-3027500	GPIO
219	P14.6	MP+ / PU1 / VEXT	-1156000	-3136000	GPIO
220	P14.7	LP / PU1 / VEXT	-1076000	-3027500	GPIO
221	P14.8	LP / PU1 / VEXT	-1016000	-3136000	GPIO
222	P14.9	MP+ / PU1 / VEXT	-936000	-3027500	GPIO
223	P14.10	MP+ / PU1 / VEXT	-836000	-3027500	GPIO
224	Reserved	Vx	-761000	-3136000	Must be bonded to VSS
225	VEXT	Vx	-711000	-3027500	Must be bonded to VEXT
226	VSS	Vx	-661000	-3136000	Must be bonded to VSS

Package and Pinning Definitions TC260 Bare Die Pad Definition:

Table 2-55 List of the TC260x Bare Die Pads

Number	Pad Name	Pad Type	X	Y	Comment
227	VEXT	Vx	-611000	-3027500	Must be bonded to VEXT
228	VSS	Vx	-531000	-3136000	Must be bonded to VSS. Double Pad (Elephant Pad), shared with Pad Nr. 228.
229	VDDP3	Vx	-508500	-3027500	Must be bonded to VDDP3
230	VSS	Vx	-486000	-3136000	Must be bonded to VSS. Double Pad (Elephant Pad), shared with Pad Nr. 226.
231	VDDP3	Vx	-391000	-3027500	Must be bonded to VDDP3
232	VDDFL3	Vx	-311000	-3136000	Must be bonded to VDDP3
233	VDDFL3	Vx	-211000	-3136000	Must be bonded to VDDP3
234	VDDFL3	Vx	-143500	-3027500	Must be bonded to VDDP3
235	VSS	Vx	-91000	-3136000	Must be bonded to VSS
236	P13.0	MP / LVDSM_N / PU1 / VEXT	-26000	-3027500	GPIO
237	P13.1	MP / LVDSM_P / PU1 / VEXT	324000	-3027500	GPIO
238	VEXT	Vx	389000	-3136000	Must be bonded to VEXT
239	P13.2	MP / LVDSM_N / PU1 / VEXT	454000	-3027500	GPIO
240	P13.3	MP / LVDSM_P / PU1 / VEXT	804000	-3027500	GPIO
241	P11.2	MPR / PU1 / VFLEX	964000	-3027500	GPIO
242	P11.3	MPR / PU1 / VFLEX	1064000	-3027500	GPIO
243	P11.6	MPR / PU1 / VFLEX	1164000	-3027500	GPIO
244	P11.9	MP+ / PU1 / VFLEX	1264000	-3027500	GPIO
245	VSSFLEX	Vx	1339000	-3136000	Must be bonded to VSS
246	VDDFLEX	Vx	1389000	-3027500	Must be bonded to VEXT or VDDP3
247	VDD	Vx	1439000	-3136000	Must be bonded to VDD
248	VSS	Vx	1539000	-3136000	Must be bonded to VSS
249	P11.10	LP / PU1 / VFLEX	1594000	-3027500	GPIO
250	P11.11	MP+ / PU1 / VFLEX	1682000	-3136000	GPIO
251	P11.12	MPR / PU1 / VFLEX	1782000	-3027500	GPIO
252	P10.0	LP / PU1 / VEXT	1932000	-3136000	GPIO

Package and Pinning Definitions TC260 Bare Die Pad Definition:

Table 2-55 List of the TC260x Bare Die Pads

Number	Pad Name	Pad Type	X	Y	Comment
253	P10.1	MP+ / PU1 / VEXT	2012000	-3027500	GPIO
254	P10.2	MP / PU1 / VEXT	2112000	-3027500	GPIO
255	VSS	Vx	2177000	-3136000	Must be bonded to VSS
256	P10.3	MP / PU1 / VEXT	2242000	-3027500	GPIO
257	P10.4	MP+ / PU1 / VEXT	2360000	-3136000	GPIO
258	P10.5	LP / PU1 / VEXT	2460000	-3136000	GPIO
259	VEXT	Vx	2515000	-3027500	Must be bonded to VEXT
260	P10.6	LP / PU1 / VEXT	2570000	-3136000	GPIO
261	P10.7	LP / PU1 / VEXT	2630000	-3027500	GPIO
262	VSS	Vx	2685000	-3136000	Must be bonded to VSS

2.4.1 TC 260 / 264 / 265 / 267 Bare Die Pad Description

Legend:

Column "**Number**":

Running number of pads in the pad frame

Column "**Name**":

Symbolic name of the pad.

The functions mapped on GPIO pads "Px.y" are described in the User's Manual chapter "General Purpose I/O Ports and Peripheral I/O Lines (Ports)"

Column "**Type**":

LP = Pad class LP (5V/3.3V, LVTTTL)

MP = Pad class MP (5V/3.3V, LVTTTL)

MP+ = Pad class MP (5V/3.3V, LVTTTL)

A2 = Pad class A2 (3.3V, LVTTTL)

LVDSM = Pad class LVDSM (LVDS/CMOS 5V/3.3V)

LVDSH = Pad class LVDSM (LVDS/CMOS 3.3V)

S = Pad class D (ADC)

D = Pad class D (ADC)

PU = with pull-up device connected during reset ($\overline{\text{PORST}} = 0$)¹⁾

PD = with pull-down device connected during reset ($\overline{\text{PORST}} = 0$)

OD = open drain during reset ($\overline{\text{PORST}} = 0$)

High-Z = tri-state during reset ($\overline{\text{PORST}} = 0$)

Column "**X**" / "**Y**":

Pad opening center coordinates

2.4.2 Pull-Up/Pull-Down Reset Behavior of the Pins

Table 2-56 List of Pull-Up/Pull-Down Reset Behavior of the Pins

Pins	$\overline{\text{PORST}} = 0$	$\overline{\text{PORST}} = 1$
all GPIOs	Pull-up if HWCFG[6] = 1 or High-Z if HWCFG[6] = 0	
$\overline{\text{TDI}}$, $\overline{\text{TESTMODE}}$	Pull-up	
$\overline{\text{PORST}}$ ¹⁾	Pull-down with I_{PORST} relevant	Pull-down with I_{PDLI} relevant
$\overline{\text{TRST}}$, TCK, TMS	Pull-down	
$\overline{\text{ESR0}}$	The open-drain driver is used to drive low. ²⁾	Pull-up ³⁾
$\overline{\text{ESR1}}$	Pull-up ³⁾	
TDO	Pull-up	High-Z/Pull-up ⁴⁾

1) Pull-down with I_{PORST} relevant is always activated when a primary supply monitor detects a violation.

2) Valid additionally after deactivation of $\overline{\text{PORST}}$ until the internal reset phase has finished. See the SCU chapter for details.

3) See the SCU_IOCR register description.

4) Depends on JTAG/DAP selection with $\overline{\text{TRST}}$.

1) The default pad reset state (PU or High-Z) can be controlled via HWCFG6 (P14.4).

Package and Pinning Definitions TC260 Bare Die Pad Definition:

In case of leakage test ($\overline{\text{PORST}} = 0$ and $\overline{\text{TESTMODE}} = 0$), the pull-down of the $\overline{\text{TRST}}$ pin is switched off. In case of an user application ($\overline{\text{TESTMODE}} = 1$), the pull-down of the $\overline{\text{TRST}}$ is always switched on.

3 Electrical Specification

3.1 Parameter Interpretation

The parameters listed in this section partly represent the characteristics of the TC 260 / 264 / 265 / 267 and partly its requirements on the system. To aid interpreting the parameters easily when evaluating them for a design, they are marked with an two-letter abbreviation in column "Symbol":

- **CC**
Such parameters indicate **C**ontroller **C**haracteristics which are a distinctive feature of the TC 260 / 264 / 265 / 267 and must be regarded for a system design.
- **SR**
Such parameters indicate **S**ystem **R**quirements which must provided by the microcontroller system in which the TC 260 / 264 / 265 / 267 designed in.

3.2 Absolute Maximum Ratings

Stresses above the values listed under “Absolute Maximum Ratings” may cause permanent damage to the device. This is a stress rating only and functional operation of the device at these or any other conditions above those indicated in the Operational Conditions of this specification is not implied. Exposure to absolute maximum rating conditions may affect device reliability.

Table 3-1 Absolute Maximum Ratings

Parameter	Symbol	Values			Unit	Note / Test Condition
		Min.	Typ.	Max.		
Storage Temperature	T_{ST} SR	-65	-	170	°C	upto 65h @ $T_J = 150^\circ\text{C}$; upto 15h @ $T_J = 170^\circ\text{C}$
Voltage at V_{DD} power supply pins with respect to V_{SS} ¹⁾	V_{DD} SR	-	-	1.9	V	
Voltage at V_{DDP3} and V_{DDFL3} power supply pins with respect to V_{SS} ¹⁾	V_{DDP3} SR	-	-	4.43	V	
Voltage at V_{DDM} , V_{EXT} and V_{FLEX} power supply pins with respect to V_{SS} ¹⁾	V_{DDM} SR	-	-	7.0	V	
Voltage on any class A2 and LVDSH input pin with respect to V_{SS} ¹⁾²⁾	V_{IN} SR	-0.5	-	$\min(V_{DDP3} + 0.6, 4.23)$	V	Whatever is lower
Voltage on all other input pins with respect to V_{SS} ¹⁾²⁾	V_{IN} SR	-0.5	-	7.0	V	
Input current on any pin during overload condition ³⁾	I_{IN} SR	-10	-	10	mA	
Absolute maximum sum of all input circuit currents during overload condition ³⁾	ΣI_{IN} SR	-100	-	100	mA	

- 1) Valid for cumulated for up to 2.8h and pulse forms following a power supply switch on phase, where the rise and fall times are related to the system capacities and coils.
- 2) Voltages below V_{INmin} have no impact to the device reliability as long as the times and currents defined in section Pin Reliability in Overload for the affected pad(s) are not violated.
- 3) This parameter is an Absolute Maximum Rating. Exposure to Absolute Maximum Ratings for extended periods of time may damage the device.

3.3 Pin Reliability in Overload

When receiving signals from higher voltage devices, low-voltage devices experience overload currents and voltages that go beyond their own IO power supplies specification.

The following table defines overload conditions that will not cause any negative reliability impact if all the following conditions are met:

- full operation life-time is not exceeded
- **Operating Conditions** are met for
 - pad supply levels
 - temperature

If a pin current is out of the **Operating Conditions** but within the overload parameters, then the parameters functionality of this pin as stated in the Operating Conditions can no longer be guaranteed. Operation is still possible in most cases but with relaxed parameters.

Note: An overload condition on one or more pins does not require a reset.

Table 3-2 Overload Parameters

Parameter	Symbol	Values			Unit	Note / Test Condition
		Min.	Typ.	Max.		
Input current on any digital pin during overload condition	I_{IN}	-5	-	5	mA	except LVDS pins
		-15 ¹⁾	-	15 ¹⁾	mA	except LVDS pins; limited to max. 20 pulses with 1ms pulse length
Input current on LVDS pin during overload condition	I_{INLVDS}	-3	-	3	mA	
Absolute maximum sum of all input circuit currents during overload condition	I_{ING}	-50	-	50	mA	
Input current on analog input pin during overload condition	I_{INANA}	-3	-	3	mA	
		-5	-	5	mA	limited to 60h over lifetime
Absolute sum of all ADC inputs during overload condition	I_{INSCA}	-20	-	20	mA	
Absolute maximum sum of all input circuit currents during overload condition	ΣI_{INS}	-100	-	100	mA	
Signal voltage over/undershoot at GPIOs	V_{OUS}	$V_{SS} - 2$	-	$V_{EXT/FLEX} + 2$	V	limited to 60h over lifetime; Valid for LP, MP, MP+, and MPR pads
Inactive device pin current during overload condition ²⁾	I_{ID}	-1	-	1	mA	All power supply voltages $V_{Ddx} = 0$
Sum of all inactive device pin currents ²⁾	I_{IDS}	-100	-	100	mA	

Electrical Specification Pin Reliability in Overload

Table 3-2 Overload Parameters (cont'd)

Parameter	Symbol	Values			Unit	Note / Test Condition
		Min.	Typ.	Max.		
Overload coupling factor for digital inputs, negative ³⁾	$K_{\text{OVDN CC}}$	-	$2 \cdot 10^{-4}$	$6 \cdot 10^{-4}$		Overload injected on GPIO non LVDS pad and affecting neighbor LP and A2 pads; $-2\text{mA} < I_{\text{IN}} < 0\text{mA}$
		-	-	$1 \cdot 10^{-2}$		Overload injected on GPIO non LVDS pad and affecting neighbor LP and A2 pads; $-5\text{mA} < I_{\text{IN}} < -2\text{mA}$
		-	-	$1.7 \cdot 10^{-3}$		Overload injected on GPIO non LVDS pad and affecting neighbor MP, MP+, and MPR pads; $-2\text{mA} < I_{\text{IN}} < 0\text{mA}$
		-	-	$2 \cdot 10^{-2}$		Overload injected on GPIO non LVDS pad and affecting neighbor MP, MP+, and MPR pads; $-5\text{mA} < I_{\text{IN}} < -2\text{mA}$
		-	-	0.3		Overload injected on LVDS pad and affecting neighbor LVDS pads
		-	-	0.93		coupling between pads 21.2 and 21.3
Overload coupling factor for digital inputs, positive ³⁾	$K_{\text{OVDP CC}}$	-	-	$1 \cdot 10^{-5}$		Overload injected on GPIO non LVDS pad and affecting neighbor GPIO non LVDS pads
		-	-	$1 \cdot 10^{-4}$		Overload injected on GPIO pad and affecting neighbor P32.0 pad
		-	-	$5 \cdot 10^{-4}$		Overload injected on LVDS pad and affecting neighbor LVDS pads

Electrical Specification Pin Reliability in Overload

Table 3-2 Overload Parameters (cont'd)

Parameter	Symbol	Values			Unit	Note / Test Condition
		Min.	Typ.	Max.		
Overload coupling factor for analog inputs, negative	K_{OVAN} CC	-	-	$6 \cdot 10^{-4}$ 4)		Analog Inputs overlaid with class LP pads or pull down diagnostics; $-1\text{mA} < I_{IN} < 0\text{mA}$
		-	-	$1 \cdot 10^{-2}$		Analog Inputs overlaid with class LP pads or pull down diagnostics; $-5\text{mA} < I_{IN} < -1\text{mA}$
		-	-	$1 \cdot 10^{-4}$		else; $-5\text{mA} < I_{IN} < 0\text{mA}$
Overload coupling factor for analog inputs, positive	K_{OVAP} CC	-	-	$1 \cdot 10^{-5}$		$5\text{mA} < I_{IN} < 0\text{mA}$

- 1) Reduced VADC / DSADC result accuracy and / or GPIO input levels (V_{IL} and V_{IH}) can differ from specified parameters.
- 2) Limitations for time and supply levels specified in this section are not valid for this parameter.
- 3) Overload is measured as increase of pad leakage caused by injection on neighbor pad.
- 4) For analogue inputs overlaid with DSADC function the VCM holdbuffer shall be enabled, in case DSADCs are enabled.

Note: DSADC input pins count as analog pins as they are overlaid with VADC pins.

Table 3-3 PN-Junction Characteristics for positive Overload

Pad Type	$I_{IN} = 3 \text{ mA}$	$I_{IN} = 5 \text{ mA}$
F / A2	$U_{IN} = V_{DDP3} + 0.5 \text{ V}$	$U_{IN} = V_{DDP3} + 0.6 \text{ V}$
LP / MP / MP+ / MPR	$U_{IN} = V_{EXT / FLEX} + 0.75 \text{ V}$	$U_{IN} = V_{EXT / FLEX} + 0.8 \text{ V}$
LVDSM	$U_{IN} = V_{EXT} + 0.75 \text{ V}$	-
LVDSH	$U_{IN} = V_{DDP3} + 0.5 \text{ V}$	-
D	$U_{IN} = V_{DDM} + 0.75 \text{ V}$	-

Table 3-4 PN-Junction Characteristics for negative Overload

Pad Type	$I_{IN} = -3 \text{ mA}$	$I_{IN} = -5 \text{ mA}$
F / A2	$U_{IN} = V_{SS} - 0.5 \text{ V}$	$U_{IN} = V_{SS} - 0.6 \text{ V}$
LP / MP / MP+ / MPR	$U_{IN} = V_{SS} - 0.75 \text{ V}$	$U_{IN} = V_{SS} - 0.8 \text{ V}$
LVDSM	$U_{IN} = V_{SS} - 0.75 \text{ V}$	-
LVDSH	$U_{IN} = V_{SS} - 0.5 \text{ V}$	-
D	$U_{IN} = V_{SS} - 0.75 \text{ V}$	-

3.4 Operating Conditions

The following operating conditions must not be exceeded in order to ensure correct operation and reliability of the TC 260 / 264 / 265 / 267. All parameters specified in the following tables refer to these operating conditions, unless otherwise noticed.

Digital supply voltages applied to the TC 260 / 264 / 265 / 267 must be static regulated voltages.

All parameters specified in the following tables refer to these operating conditions (see table below), unless otherwise noticed in the Note / Test Condition column.

Table 3-5 Operating Conditions

Parameter	Symbol	Values			Unit	Note / Test Condition
		Min.	Typ.	Max.		
SRI frequency	f_{SRI} SR	-	-	200	MHz	
Max System Frequency	f_{MAX} SR	-	-	200	MHz	
CPU0 Frequency	f_{CPU0} SR	-	-	200	MHz	
CPU1 Frequency	f_{CPU1} SR	-	-	200	MHz	
PLL output frequency	f_{PLL} SR	20	-	200	MHz	
PLL_ERAY output frequency	$f_{PLLERAY}$ SR	20	-	400	MHz	
SPB frequency	f_{SPB} SR	-	-	100	MHz	
ASCLIN fast frequency	$f_{ASCLINF}$ SR	-	-	200	MHz	
ASCLIN slow frequency	$f_{ASCLINS}$ SR	-	-	100	MHz	
Baud2 frequency	f_{BAUD2} SR	-	-	200	MHz	
Baud1 frequency	f_{BAUD1} SR	-	-	100	MHz	
FSI2 frequency	f_{FSI2} SR	-	-	200	MHz	
FSI frequency	f_{FSI} SR	-	-	100	MHz	
GTM frequency	f_{GTM} SR	-	-	100	MHz	
STM frequency	f_{STM} SR	-	-	100	MHz	
ERAY frequency	f_{ERAY} SR	-	-	80	MHz	
BBB frequency	f_{BBB} SR	-	-	100	MHz	
MultiCAN frequency	f_{CAN} SR	-	-	100	MHz	
Absolute sum of short circuit currents of the device	ΣI_{SC_D} SR	-	-	100	mA	
Ambient Temperature	T_A SR	-40	-	125	°C	valid for all SAK products
		-40	-	150	°C	valid for all SAL products
		-40	-	170	°C	valid for all SAL products without package
Junction Temperature	T_J SR	-40	-	150	°C	valid for all SAK products
		-40	-	170	°C	valid for all SAL products

Electrical Specification Operating Conditions

Table 3-5 Operating Conditions (cont'd)

Parameter	Symbol	Values			Unit	Note / Test Condition
		Min.	Typ.	Max.		
Core Supply Voltage ¹⁾	V_{DD} SR	1.17	1.3	1.43 ²⁾	V	Only required if externally supplied
ADC analog supply voltage	V_{DDM} SR	2.97	5.0	5.5 ³⁾	V	
Digital external supply voltage for LP, MP, MP+ and LVDSM pads and EVR ⁴⁾	V_{EXT} SR	2.97	-	4.5	V	3.3V pad parameters are valid
		4.5	5.0	5.5 ³⁾	V	5V pad parameters are valid
Digital supply voltage for Flex port	V_{FLEX} SR	2.97	-	4.5	V	3.3V pad parameters are valid
		4.5	5.0	5.5 ³⁾	V	5V pad parameters are valid
Digital supply voltage for LVDSH and A2 pads ⁵⁾	V_{DDP3} SR	2.97	3.3	3.63 ⁶⁾	V	3.3V pad parameters are valid; only required if externally supplied
Flash supply voltage 3.3V ¹⁾	V_{DDFL3} SR	2.97	3.3	3.63	V	Only required if externally supplied
Digital ground voltage	V_{SS} SR	0	-	-	V	
Analog ground voltage for V_{DDM}	V_{SSM} CC	-0.1	0	0.1	V	
Voltage to ensure defined pad states ⁷⁾	V_{DDPPA} CC	0.72	-	-	V	A2 and LVDSH
		1.4	-	-	V	LP, MP, MP+, MPR and LVDSM
Digital supply voltage for GPIO pads and EVR ⁵⁾	V_{DDP3} SR	2.97	3.3	3.63	V	
SCR CCLK frequency	f_{CCLK} SR	0.07	-	20	MHz	
SCR PCLK frequency	f_{PCLK} SR	0.07	-	20	MHz	
SCR RTC frequency	f_{RTC} SR	0.0002	-	20	MHz	
SCR WDT frequency	f_{WDTCLK} SR	0.00078	-	20	MHz	

- 1) No external inductive load permissible if EVR is used. All V_{DD} pins shall be connected together externally on the PCB.
- 2) Voltage overshoot to 1.69V is permissible, provided the duration is less than 2h cumulated. Reduced ADC accuracy and leakage is increased.
- 3) Voltage overshoot to 6.5V is permissible, provided the duration is less than 2h cumulated. Reduced ADC accuracy and leakage is increased.
- 4) All V_{EXT} pins shall be connected together externally on the PCB.
- 5) All V_{DDP3} pins shall be connected together externally on the PCB.
- 6) Voltage overshoot to 4.29V is permissible, provided the duration is less than 2h cumulated. Reduced ADC accuracy and leakage is increased.
- 7) This parameter is valid under the assumption the PORST signal is constantly at low level during the power-up/power-down of V_{DDP3} .

3.5 5 V / 3.3 V switchable Pads

Pad classes LP, MP, MP+, and MPR support both Automotive Level (AL) or TTL level (TTL) operation. Parameters are defined for AL operation and degrade in TTL operation.

Table 3-6 Standard_Pads

Parameter	Symbol	Values			Unit	Note / Test Condition
		Min.	Typ.	Max.		
Pin capacitance (digital inputs/outputs)	C_{IO} CC	-	6	10	pF	
Spike filter always blocked pulse duration	t_{SF1} CC	-	-	80	ns	PORST only
Spike filter pass-through pulse duration	t_{SF2} CC	220	-	-	ns	PORST only
PORST pad output current ¹⁾	I_{PORST} CC	11	-	-	mA	$V_{EXT} = 3.0V$; $V_{PORST} = 0.9V$; $T_J = 165^{\circ}C$
		13	-	-	mA	$V_{EXT} = 4.5V$; $V_{PORST} = 1.0V$

1) Pull-down with I_{PORST} relevant is always activated when a primary supply monitor detects a violation.

Table 3-7 Class LP 5V

Parameter	Symbol	Values			Unit	Note / Test Condition
		Min.	Typ.	Max.		
Input frequency	f_{IN} SR	-	-	75	MHz	Hysteresis active
		-	-	150	MHz	Hysteresis inactive
Input Hysteresis for LP pad ¹⁾	$HYSLP$ CC	0.09 * $V_{EXT/FLEX}$	-	-	V	AL
		0.075 * $V_{EXT/FLEX}$	-	-	V	TTL
Input Leakage current for LP pad	I_{OZLP} CC	-150	-	150	nA	$(0.1 * V_{EXT/FLEX}) < V_{IN} < (0.9 * V_{EXT/FLEX})$
		-350	-	350	nA	else
Input leakage current for P32.0	$I_{OZP32.0}$ CC	-4900	-	4900	nA	$(0.1 * V_{EXT/FLEX}) < V_{IN} < (0.9 * V_{EXT/FLEX})$
		-9400	-	9400	nA	$(0.1 * V_{EXT/FLEX}) < V_{IN} < (0.9 * V_{EXT/FLEX})$; for $T_J > 150^{\circ}C$
		-5800	-	5800	nA	else
		-12000	-	12000	nA	else; for $T_J > 150^{\circ}C$
Pull-up current for LP pad	I_{PUHLP} CC	30	-	-	μA	V_{IHmin} ; AL
		43	-	-	μA	V_{IHmin} ; TTL
		-	-	107	μA	V_{ILmax} ; AL and TTL

Electrical Specification 5 V / 3.3 V switchable Pads

Table 3-7 Class LP 5V (cont'd)

Parameter	Symbol	Values			Unit	Note / Test Condition
		Min.	Typ.	Max.		
Pull-down current for LP pad	I_{PDLLP} CC	-	-	100	μA	V_{IHmin} ; AL and TTL
		46	-	-	μA	V_{ILmax} ; AL
		21	-	-	μA	V_{ILmax} ; TTL
On-Resistance for LP pad, weak driver ²⁾	$R_{DSONLPW}$ CC	200	620	1040	Ohm	PMOS/NMOS ; $I_{OH}=0.5\text{mA}$; $I_{OL}=0.5\text{mA}$
On-Resistance for LP pad, medium driver ²⁾	$R_{DSONLPM}$ CC	50	155	260	Ohm	PMOS/NMOS ; $I_{OH}=2\text{mA}$; $I_{OL}=2\text{mA}$
Rise / fall time for LP pad ³⁾	t_{LP} CC	-	-	$95+2.1 * C_L$	ns	$C_L \leq 50\text{pF}$; pin out driver=weak
		-	-	$200+2.9 * (C_L - 50)$	ns	$C_L \geq 50\text{pF}$; $C_L \leq 200\text{pF}$; pin out driver=weak
		-	-	$25+0.5 * C_L$	ns	$C_L \leq 50\text{pF}$; pin out driver=medium
		-	-	$50+0.75 * (C_L - 50)$	ns	$C_L \geq 50\text{pF}$; $C_L \leq 200\text{pF}$; pin out driver=medium
Input high voltage for LP pad	$V_{IHL P}$ SR	$(0.73 * V_{EX} - 0.25)$ $T/FLEX$	-	-	V	Hysteresis active, AL
		2.03 ⁴⁾	-	-	V	Hysteresis active, TTL
Input low voltage for LP pad	$V_{ILL P}$ SR	-	-	$(0.52 * V_{EX} - 0.25)$ $T/FLEX$	V	Hysteresis active, AL
		-	-	0.8 ⁵⁾	V	Hysteresis active, TTL
Input low / high voltage for LP pad	V_{ILHLP} CC	1.85	-	3.0	V	Hysteresis inactive; not available for P14.2, P14.4, and P15.1
Pad set-up time for LP pad	t_{SET_LP} CC	-	-	100	ns	
Input leakage current for P02.1	I_{OZ021} CC	-150	-	1030	nA	$(0.1 * V_{EXT/FLEX}) < V_{IN} < (0.9 * V_{EXT/FLEX})$; $T_J > 150^\circ\text{C}$
		-150	-	340	nA	$(0.1 * V_{EXT/FLEX}) < V_{IN} < (0.9 * V_{EXT/FLEX})$; $T_J = 150^\circ\text{C}$
		-420	-	1100	nA	else; $T_J > 150^\circ\text{C}$
		-350	-	380	nA	else; $T_J = 150^\circ\text{C}$
Pull down current for P32_0 pin	$I_{PDL P320}$ CC	-	-	105	μA	V_{IHmin} ; AL and TTL
		41	-	-	μA	V_{ILmax} ; AL
		16	-	-	μA	V_{ILmax} ; TTL
Pull Up Current for P32_0 pin	$I_{PUHP320}$ CC	25	-	-	μA	V_{IHmin} ; AL
		38	-	-	μA	V_{IHmin} ; TTL
		-	-	112	μA	V_{ILmax} ; AL and TTL

Electrical Specification 5 V / 3.3 V switchable Pads

Table 3-7 Class LP 5V (cont'd)

Parameter	Symbol	Values			Unit	Note / Test Condition
		Min.	Typ.	Max.		
Short Circuit current for LP pad 6)	I_{SC} SR	-10	-	10	mA	absolute max value (PSI5)
Deviation of symmetry for rising and falling edges	SYM CC	-	-	20	%	

- 1) Hysteresis is implemented to avoid metastable states and switching due to internal ground bounce. It can't be guaranteed that it suppresses switching due to external system noise.
- 2) For currents smaller than the $I_{OL/OH}$ from the test condition the defined Max. value stays unchanged.
- 3) Rise / fall times are defined 10% - 90% of $V_{EXT/FLEX}$.
- 4) $V_{IHx} = 0.27 * V_{EXT/FLEX} + 0.545V$
- 5) $V_{ILx} = 0.17 * V_{EXT/FLEX}$
- 6) The values are only valid if the pad is not used during operation, otherwise I_{SC} defines the limits for operation.

Table 3-8 Class LP 3.3V

Parameter	Symbol	Values			Unit	Note / Test Condition
		Min.	Typ.	Max.		
Input frequency	f_{IN} SR	-	-	50	MHz	Hysteresis active
		-	-	100	MHz	Hysteresis inactive
Input Hysteresis for LP pad ¹⁾	$HYSLP$ CC	0.05 * $V_{EXT/FLEX}$	-	-	V	AL and TTL
Input Leakage current for LP pad	I_{OZLP} CC	-150	-	150	nA	$(0.1 * V_{EXT/FLEX}) < V_{IN} <$ $(0.9 * V_{EXT/FLEX})$
		-350	-	350	nA	else
Input leakage current for P32.0	I_{OZP320} CC	-4900	-	4900	nA	$(0.1 * V_{EXT/FLEX}) < V_{IN} <$ $(0.9 * V_{EXT/FLEX})$
		-9400	-	9400	nA	$(0.1 * V_{EXT/FLEX}) < V_{IN} <$ $(0.9 * V_{EXT/FLEX})$; for $T_J >$ 150 °C
		-5800	-	5900	nA	else
		-12000	-	12000	nA	else; for $T_J > 150^{\circ}C$
Pull-up current for LP pad	I_{PUHLP} CC	17	-	-	μA	V_{IHmin} ; AL
		19	-	-	μA	V_{IHmin} ; TTL
		-	-	75	μA	V_{ILmax} ; AL and TTL
Pull-down current for LP pad	I_{PDLLP} CC	-	-	75	μA	V_{IHmin} ; AL and TTL
		22	-	-	μA	V_{ILmax} ; AL
		11	-	-	μA	V_{ILmax} ; TTL
On-Resistance for LP pad, weak driver ²⁾	$R_{DSONLPW}$ CC	250	875	1500	Ohm	; NMOS/PMOS ; $I_{OH}=0.25mA$; $I_{OL}=0.25mA$
On-Resistance for LP pad, medium driver ²⁾	$R_{DSONLPM}$ CC	70	235	400	Ohm	; NMOS/PMOS ; $I_{OH}=1mA$; $I_{OL}=1mA$

Electrical Specification 5 V / 3.3 V switchable Pads

Table 3-8 Class LP 3.3V (cont'd)

Parameter	Symbol	Values			Unit	Note / Test Condition
		Min.	Typ.	Max.		
Rise / fall time for LP pad ³⁾	$t_{LP\ CC}$	-	-	$150+3.4 * C_L$	ns	$C_L \leq 50\text{pF}$; pin out driver=weak
		-	-	$320+4.5 * (C_L - 50)$	ns	$C_L \geq 50\text{pF}$; $C_L \leq 200\text{pF}$; pin out driver=weak
		-	-	$30+0.8 * C_L$	ns	$C_L \leq 50\text{pF}$; pin out driver=medium
		-	-	$70+1.1 * (C_L - 50)$	ns	$C_L \geq 50\text{pF}$; $C_L \leq 200\text{pF}$; pin out driver=medium
Input high voltage for LP pad	$V_{IHLP\ SR}$	$(0.73 * V_{EX\ T/FLEX}) - 0.25$	-	-	V	Hysteresis active, AL
		$1.6^{4)}$	-	-	V	Hysteresis active, TTL
Input low voltage for LP pad	$V_{ILLP\ SR}$	-	-	$(0.52 * V_{EX\ T/FLEX}) - 0.25$	V	Hysteresis active, AL
		-	-	$0.5^{5)}$	V	Hysteresis active, TTL
Input low / high voltage for LP pad	$V_{ILHLP\ CC}$	1.1	-	1.9	V	Hysteresis inactive; not available for P14.2, P14.4, and P15.1
Pad set-up time for LP pad	$t_{SET_LP\ CC}$	-	-	100	ns	
Input leakage current for P02.1	$I_{OZ021\ CC}$	-150	-	920	nA	$(0.1 * V_{EXT/FLEX}) < V_{IN} < (0.9 * V_{EXT/FLEX})$; $T_J > 150^\circ\text{C}$
		-150	-	330	nA	$(0.1 * V_{EXT/FLEX}) < V_{IN} < (0.9 * V_{EXT/FLEX})$; $T_J = 150^\circ\text{C}$
		-360	-	1000	nA	else; $T_J > 150^\circ\text{C}$
		-350	-	375	nA	else; $T_J = 150^\circ\text{C}$
Pull down current for P32_0 pin	$I_{PDLP320\ CC}$	-	-	80	μA	V_{IHmin} ; AL and TTL
		17	-	-	μA	V_{ILmax} ; AL
		6	-	-	μA	V_{ILmax} ; TTL
Pull Up Current for P32_0 pin	$I_{PUHP320\ CC}$	12	-	-	μA	V_{IHmin} ; AL
		14	-	-	μA	V_{IHmin} ; TTL
		-	-	80	μA	V_{ILmax} ; AL and TTL
Short Circuit current for LP pad ⁶⁾	$I_{SC\ SR}$	-10	-	10	mA	absolute max value (PSI5)
Deviation of symmetry for rising and falling edges	$SYM\ CC$	-	-	20	%	

1) Hysteresis is implemented to avoid metastable states and switching due to internal ground bounce. It can't be guaranteed that it suppresses switching due to external system noise.

2) For currents smaller than the $I_{OL/OH}$ from the test condition the defined Max. value stays unchanged.

Electrical Specification 5 V / 3.3 V switchable Pads

- 3) Rise / fall times are defined 10% - 90% of $V_{EXT/FLEX}$.
- 4) $V_{IHx} = 0.27 * V_{EXT/FLEX} + 0.545V$
- 5) $V_{ILx} = 0.17 * V_{EXT/FLEX}$
- 6) The values are only valid if the pad is not used during operation, otherwise I_{SC} defines the limits for operation.

Table 3-9 Class MP 5V

Parameter	Symbol	Values			Unit	Note / Test Condition
		Min.	Typ.	Max.		
Input frequency	f_{IN} SR	-	-	75	MHz	Hysteresis active
		-	-	150	MHz	Hysteresis inactive
Input Hysteresis for MP pad ¹⁾	$HYSMP$ CC	0.09 * $V_{EXT/FLEX}$	-	-	V	AL
		0.075 * $V_{EXT/FLEX}$	-	-	V	TTL
Input Leakage current for MP pad	I_{OZMP} CC	-500	-	500	nA	$(0.1 * V_{EXT/FLEX}) < V_{IN} < (0.9 * V_{EXT/FLEX})$
		-1000	-	1000	nA	else
Pull-up current for MP pad	I_{PUHMP} CC	30	-	-	μA	V_{IHmin} ; AL
		43	-	-	μA	V_{IHmin} ; TTL
		-	-	107	μA	V_{ILmax} ; AL and TTL
Pull-down current for MP pad	I_{PDLMP} CC	-	-	100	μA	V_{IHmin} ; AL and TTL
		46	-	-	μA	V_{ILmax} ; AL
		21	-	-	μA	V_{ILmax} ; TTL
On-Resistance for MP pad, weak driver ²⁾	$R_{DSONMPW}$ CC	200	620	1040	Ohm	PMOS/NMOS ; $I_{OH}=0.5mA$; $I_{OL}=0.5mA$
On-Resistance for MP pad, medium driver ²⁾	$R_{DSONMPM}$ CC	50	155	260	Ohm	PMOS/NMOS ; $I_{OH}=2mA$; $I_{OL}=2mA$
On-Resistance for MP pad, strong driver ²⁾	$R_{DSONMPS}$ CC	20	75	130	Ohm	PMOS/NMOS ; $I_{OH}=8mA$; $I_{OL}=8mA$

Electrical Specification 5 V / 3.3 V switchable Pads

Table 3-9 Class MP 5V (cont'd)

Parameter	Symbol	Values			Unit	Note / Test Condition
		Min.	Typ.	Max.		
Rise / fall time for MP pad ³⁾	$t_{MP\ CC}$	-	-	$95+2.1 \cdot C_L$	ns	$C_L \leq 50\text{pF}$; pin out driver=weak
		-	-	$200+2.9 \cdot (C_L-50)$	ns	$C_L \geq 50\text{pF}$; $C_L \leq 200\text{pF}$; pin out driver=weak
		-	-	$25+0.5 \cdot C_L$	ns	$C_L \leq 50\text{pF}$; pin out driver=medium
		-	-	$50 + 0.75 \cdot (C_L - 50)$	ns	$C_L \geq 50\text{pF}$; $C_L \leq 200\text{pF}$; pin out driver=medium
		-	-	$17.5+0.25 \cdot C_L$	ns	$C_L \leq 50\text{pF}$; edge=medium ; pin out driver=strong
		-	-	$30+0.3 \cdot (C_L-50)$	ns	$C_L \geq 50\text{pF}$; $C_L \leq 200\text{pF}$; edge=medium ; pin out driver=strong
		-	-	$7+0.2 \cdot C_L$	ns	$C_L \leq 50\text{pF}$; edge=sharp ; pin out driver=strong
		-	-	$17+0.3 \cdot (C_L-50)$	ns	$C_L \geq 50\text{pF}$; $C_L \leq 200\text{pF}$; edge=sharp ; pin out driver=strong
Input high voltage for MP pad	$V_{IHMP\ SR}$	$(0.73 \cdot V_{EXT/FLEX}) - 0.25$	-	-	V	Hysteresis active, AL
		2.03 ⁴⁾	-	-	V	Hysteresis active, TTL
Input low voltage for MP pad	$V_{ILMP\ SR}$	-	-	$(0.52 \cdot V_{EXT/FLEX}) - 0.25$	V	Hysteresis active, AL
		-	-	0.8 ⁵⁾	V	Hysteresis active, TTL
Input low / high voltage for MP pad	$V_{ILHMP\ CC}$	1.85	-	3.0	V	Hysteresis inactive
Pad set-up time for MP pad	$t_{SET_MP\ CC}$	-	-	100	ns	
Short Circuit current for MP pad ⁶⁾	$I_{SC\ SR}$	-10	-	10	mA	absolute max value (PSI5)
Deviation of symmetry for rising and falling edges	$SYM\ CC$	-	-	20	%	

1) Hysteresis is implemented to avoid metastable states and switching due to internal ground bounce. It can't be guaranteed that it suppresses switching due to external system noise.

2) For currents smaller than the $I_{OL/OH}$ from the test condition the defined Max. value stays unchanged.

3) Rise / fall times are defined 10% - 90% of $V_{EXT/FLEX}$.

4) $V_{IHx} = 0.27 \cdot V_{EXT/FLEX} + 0.545\text{V}$

5) $V_{ILx} = 0.17 \cdot V_{EXT/FLEX}$

6) The values are only valid if the pad is not used during operation, otherwise I_{SC} defines the limits for operation.

Electrical Specification 5 V / 3.3 V switchable Pads

Table 3-10 Class MP 3.3V

Parameter	Symbol	Values			Unit	Note / Test Condition
		Min.	Typ.	Max.		
Input frequency	f_{IN} SR	-	-	50	MHz	Hysteresis active
		-	-	100	MHz	Hysteresis inactive
Input Hysteresis for MP pad ¹⁾	$HYSMP$ CC	0.05 * $V_{EXT/FLEX}$	-	-	V	AL and TTL
Input Leakage current for MP pad	I_{OZMP} CC	-500	-	500	nA	$(0.1 * V_{EXT/FLEX}) < V_{IN} < (0.9 * V_{EXT/FLEX})$
		-1000	-	1000	nA	else
Pull-up current for MP pad	I_{PUHMP} CC	17	-	-	μ A	V_{IHmin} ; AL
		19	-	-	μ A	V_{IHmin} ; TTL
		-	-	75	μ A	V_{ILmax} ; AL and TTL
Pull-down current for MP pad	I_{PDLMP} CC	-	-	75	μ A	V_{IHmin} ; AL and TTL
		22	-	-	μ A	V_{ILmax} ; AL
		11	-	-	μ A	V_{ILmax} ; TTL
On-Resistance for MP pad, weak driver ²⁾	$R_{DSONMPW}$ CC	250	875	1500	Ohm	; NMOS/PMOS ; $I_{OH}=0.25mA$; $I_{OL}=0.25mA$
On-Resistance for MP pad, medium driver ²⁾	$R_{DSONMPM}$ CC	70	235	400	Ohm	; NMOS/PMOS ; $I_{OH}=1mA$; $I_{OL}=1mA$
On-Resistance for MP pad, strong driver ²⁾	$R_{DSONMPS}$ CC	20	110	200	Ohm	PMOS/NMOS ; $I_{OH}=4mA$; $I_{OL}=4mA$
Rise / fall time for MP pad ³⁾	t_{MP} CC	-	-	$150+3.4 * C_L$	ns	$C_L \leq 50pF$; pin out driver=weak
		-	-	$320+4.5 * (C_L-50)$	ns	$C_L \geq 50pF$; $C_L \leq 200pF$; pin out driver=weak
		-	-	$30+0.8 * C_L$	ns	$C_L \leq 50pF$; pin out driver=medium
		-	-	$70+1.1 * (C_L-50)$	ns	$C_L \geq 50pF$; $C_L \leq 200pF$; pin out driver=medium
		-	-	$32.5+0.35 * C_L$	ns	$C_L \leq 50pF$; edge=medium ; pin out driver=strong
		-	-	$50+0.45 * (C_L-50)$	ns	$C_L \geq 50pF$; $C_L \leq 200pF$; edge=medium ; pin out driver=strong
		-	-	$14.5+0.35 * C_L$	ns	$C_L \leq 50pF$; edge=sharp ; pin out driver=strong
		-	-	$32+0.5 * (C_L-50)$	ns	$C_L \geq 50pF$; $C_L \leq 200pF$; edge=sharp ; pin out driver=strong

Electrical Specification 5 V / 3.3 V switchable Pads

Table 3-10 Class MP 3.3V (cont'd)

Parameter	Symbol	Values			Unit	Note / Test Condition
		Min.	Typ.	Max.		
Input high voltage for MP pad	V_{IHMP} SR	$(0.73 \cdot V_{EX})^{T/FLEX} - 0.25$	-	-	V	Hysteresis active, AL
		1.6 ⁴⁾	-	-	V	Hysteresis active, TTL
Input low voltage for MP pad	V_{ILMP} SR	-	-	$(0.52 \cdot V_{EX})^{T/FLEX} - 0.25$	V	Hysteresis active, AL
		-	-	0.5 ⁵⁾	V	Hysteresis active, TTL
Input low / high voltage for MP pad	V_{ILHMP} CC	1.1	-	1.9	V	Hysteresis inactive
Pad set-up time for MP pad	t_{SET_MP} CC	-	-	100	ns	
Short Circuit current for MP pad ⁶⁾	I_{SC} SR	-10	-	10	mA	absolute max value (PSI5)
Deviation of symmetry for rising and falling edges	SYM CC	-	-	20	%	

- Hysteresis is implemented to avoid metastable states and switching due to internal ground bounce. It can't be guaranteed that it suppresses switching due to external system noise.
- For currents smaller than the $I_{OL/OH}$ from the test condition the defined Max. value stays unchanged.
- Rise / fall times are defined 10% - 90% of $V_{EXT/FLEX}$.
- $V_{IHx} = 0.27 \cdot V_{EXT/FLEX} + 0.545V$
- $V_{ILx} = 0.17 \cdot V_{EXT/FLEX}$
- The values are only valid if the pad is not used during operation, otherwise I_{SC} defines the limits for operation.

Table 3-11 Class MP+ 5V

Parameter	Symbol	Values			Unit	Note / Test Condition
		Min.	Typ.	Max.		
Input frequency	f_{IN} SR	-	-	75	MHz	Hysteresis active
		-	-	150	MHz	Hysteresis inactive
Input hysteresis for MP+ pad ¹⁾	$HYSMPP$ CC	$0.09 \cdot V_{EXT/FLEX}$	-	-	V	AL
		$0.075 \cdot V_{EXT/FLEX}$	-	-	V	TTL
Input leakage current for MP+ pad	I_{OZMPP} CC	-750	-	750	nA	$(0.1 \cdot V_{EXT/FLEX}) < V_{IN} < (0.9 \cdot V_{EXT/FLEX})$
		-1500	-	1500	nA	else
Pull-up current for MP+ pad	I_{PUHMPP} CC	30	-	-	μA	V_{IHmin} ; AL
		43	-	-	μA	V_{IHmin} ; TTL
		-	-	107	μA	V_{ILmax} ; AL and TTL
Pull-down current for MP+ pad	I_{PDLMP} CC	-	-	100	μA	V_{IHmin} ; AL and TTL
		46	-	-	μA	V_{ILmax} ; AL
		21	-	-	μA	V_{ILmax} ; TTL

Electrical Specification 5 V / 3.3 V switchable Pads

Table 3-11 Class MP+ 5V (cont'd)

Parameter	Symbol	Values			Unit	Note / Test Condition
		Min.	Typ.	Max.		
On-resistance for MP+ pad, weak driver ²⁾	$R_{DSONMPPW}$ CC	200	620	1040	Ohm	PMOS/NMOS ; $I_{OH}=0.5mA$; $I_{OL}=0.5mA$
On-resistance for MP+ pad, medium driver ²⁾	$R_{DSONMPPM}$ CC	50	155	260	Ohm	PMOS/NMOS ; $I_{OH}=2mA$; $I_{OL}=2mA$
On-resistance for MP+ pad, strong driver ²⁾	$R_{DSONMPPS}$ CC	20	55	90	Ohm	PMOS/NMOS ; $I_{OH}=8mA$; $I_{OL}=8mA$
Rise/fall time for MP+ pad ³⁾	t_{MPP} CC	-	-	$95+2.1 \cdot C_L$	ns	$C_L \leq 50pF$; pin out driver=weak
		-	-	$200+2.9 \cdot (C_L-50)$	ns	$C_L \geq 50pF$; $C_L \leq 200pF$; pin out driver=weak
		-	-	$25+0.5 \cdot C_L$	ns	$C_L \leq 50pF$; pin out driver=medium
		-	-	$50+0.75 \cdot (C_L-50)$	ns	$C_L \geq 50pF$; $C_L \leq 200pF$; pin out driver=medium
		-	-	$9+0.16 \cdot C_L$	ns	$C_L \leq 50pF$; edge=medium ; pin out driver=strong
		-	-	$17+0.2 \cdot (C_L-50)$	ns	$C_L \geq 50pF$; $C_L \leq 200pF$; edge=medium ; pin out driver=strong
		-	-	$4+0.16 \cdot C_L$	ns	$C_L \leq 50pF$; edge=sharp ; pin out driver=strong
		-	-	$12+0.21 \cdot (C_L-50)$	ns	$C_L \geq 50pF$; $C_L \leq 200pF$; edge=sharp ; pin out driver=strong
		-	-	5	ns	from 0.8V to 2.0V (RMII) ; $C_L=25pF$; edge=sharp ; pin out driver=strong
		-	-	4.5	ns	$C_L=15pF$; edge=sharp ; pin out driver=strong
Input high voltage for MP+ pad	V_{IHMP} SR	$(0.73 \cdot V_{EX} - 0.25)$	-	-	V	Hysteresis active, AL
		2.03 ⁴⁾	-	-	V	Hysteresis active, TTL
Input low voltage for MP+ pad	V_{ILMP} SR	-	-	$(0.52 \cdot V_{EX} - 0.25)$	V	Hysteresis active, AL
		-	-	0.8 ⁵⁾	V	Hysteresis active, TTL
Input low / high voltage for MP+ pad	V_{ILHMP} CC	1.85	-	3.0	V	Hysteresis inactive
Pad set-up time for MP+ pad	t_{SET_MPP} CC	-	-	100	ns	

Electrical Specification 5 V / 3.3 V switchable Pads

Table 3-11 Class MP+ 5V (cont'd)

Parameter	Symbol	Values			Unit	Note / Test Condition
		Min.	Typ.	Max.		
Short circuit current for MP+ pad ⁶⁾	I_{SCMPP} SR	-10	-	10	mA	absolute max value (PSI5)
Deviation of symmetry for rising and falling edges	SYM CC	-	-	20	%	

- 1) Hysteresis is implemented to avoid metastable states and switching due to internal ground bounce. It can't be guaranteed that it suppresses switching due to external system noise.
- 2) For currents smaller than the $I_{OL/OH}$ from the test condition the defined Max. value stays unchanged.
- 3) Rise / fall times are defined 10% - 90% of $V_{EXT/FLEX}$.
- 4) $V_{IHx} = 0.27 * V_{EXT/FLEX} + 0.545V$
- 5) $V_{ILx} = 0.17 * V_{EXT/FLEX}$
- 6) The values are only valid if the pad is not used during operation, otherwise I_{SC} defines the limits for operation.

Table 3-12 Class MP+ 3.3V

Parameter	Symbol	Values			Unit	Note / Test Condition
		Min.	Typ.	Max.		
Input frequency	f_{IN} SR	-	-	50	MHz	Hysteresis active
		-	-	100	MHz	Hysteresis inactive
Input hysteresis for MP+ pad ¹⁾	$HYSMPP$ CC	0.05 * $V_{EXT/FLEX}$	-	-	V	AL and TTL
Input leakage current for MP+ pad	I_{OZMPP} CC	-750	-	750	nA	$(0.1 * V_{EXT/FLEX}) < V_{IN} < (0.9 * V_{EXT/FLEX})$
		-1500	-	1500	nA	else
Pull-up current for MP+ pad	I_{PUHMPP} CC	17	-	-	μA	V_{IHmin} ; AL
		19	-	-	μA	V_{IHmin} ; TTL
		-	-	75	μA	V_{ILmax} ; AL and TTL
Pull-down current for MP+ pad	I_{PDLMPP} CC	-	-	75	μA	V_{IHmin} ; AL and TTL
		22	-	-	μA	V_{ILmax} ; AL
		11	-	-	μA	V_{ILmax} ; TTL
On-resistance for MP+ pad, weak driver ²⁾	$R_{DSONMPPW}$ CC	250	875	1500	Ohm	; NMOS/PMOS ; $I_{OH}=0.25mA$; $I_{OL}=0.25mA$
On-resistance for MP+ pad, medium driver ²⁾	$R_{DSONMPPM}$ CC	70	235	400	Ohm	; NMOS/PMOS ; $I_{OH}=1mA$; $I_{OL}=1mA$
On-resistance for MP+ pad, strong driver ²⁾	$R_{DSONMPPS}$ CC	20	75	130	Ohm	PMOS/NMOS ; $I_{OH}=4mA$; $I_{OL}=4mA$

Electrical Specification 5 V / 3.3 V switchable Pads

Table 3-12 Class MP+ 3.3V (cont'd)

Parameter	Symbol	Values			Unit	Note / Test Condition
		Min.	Typ.	Max.		
Rise/fall time for MP+ pad ³⁾	$t_{MPP\ CC}$	-	-	150+3.4* C_L	ns	$C_L \leq 50\text{pF}$; pin out driver=weak
		-	-	320+4.5*(C_L-50)	ns	$C_L \geq 50\text{pF}$; $C_L \leq 200\text{pF}$; pin out driver=weak
		-	-	30+0.8* C_L	ns	$C_L \leq 50\text{pF}$; pin out driver=medium
		-	-	70+1.1*(C_L-50)	ns	$C_L \geq 50\text{pF}$; $C_L \leq 200\text{pF}$; pin out driver=medium
		-	-	20+0.2* C_L	ns	$C_L \leq 50\text{pF}$; edge=medium ; pin out driver=strong
		-	-	30+0.3*(C_L-50)	ns	$C_L \geq 50\text{pF}$; $C_L \leq 200\text{pF}$; edge=medium ; pin out driver=strong
		-	-	13+0.2* C_L	ns	$C_L \leq 50\text{pF}$; edge=sharp ; pin out driver=strong
		-	-	7.65	ns	$C_L = 15\text{pF}$; $V_{EXT/FLEX} = 3.135\text{V}$; $V = 0\text{V}$ to 2.0V; edge=sharp ; pin out driver=strong
		-	-	5.42	ns	$C_L = 15\text{pF}$; $V_{EXT/FLEX} = 3.135\text{V}$; $V = 3.135\text{V}$ to 0.8V; edge=sharp ; pin out driver=strong
		-	-	7.36	ns	$C_L = 15\text{pF}$; $V_{EXT/FLEX} = 3.201\text{V}$; $V = 0\text{V}$ to 2.0V; edge=sharp ; pin out driver=strong
		-	-	5.32	ns	$C_L = 15\text{pF}$; $V_{EXT/FLEX} = 3.201\text{V}$; $V = 3.201\text{V}$ to 0.8V; edge=sharp ; pin out driver=strong
		-	-	5.9	ns	$C_L = 15\text{pF}$; $V_{EXT/FLEX} = 3.63\text{V}$; $V = 0\text{V}$ to 2.0V; edge=sharp ; pin out driver=strong
		-	-	4.8	ns	$C_L = 15\text{pF}$; $V_{EXT/FLEX} = 3.63\text{V}$; $V = 3.63\text{V}$ to 0.8V; edge=sharp ; pin out driver=strong
		-	-	23+0.3*(C_L-50)	ns	$C_L \geq 50\text{pF}$; $C_L \leq 200\text{pF}$; edge=sharp ; pin out driver=strong

Electrical Specification 5 V / 3.3 V switchable Pads

Table 3-12 Class MP+ 3.3V (cont'd)

Parameter	Symbol	Values			Unit	Note / Test Condition
		Min.	Typ.	Max.		
Input high voltage for MP+ pad	V_{IHMP+} SR	$(0.73 \cdot V_{EX})^{T/FLEX} - 0.25$	-	-	V	Hysteresis active, AL
		1.6 ⁴⁾	-	-	V	Hysteresis active, TTL
Input low voltage for MP+ pad	V_{ILMP+} SR	-	-	$(0.52 \cdot V_{EX})^{T/FLEX} - 0.25$	V	Hysteresis active, AL
		-	-	0.5 ⁵⁾	V	Hysteresis active, TTL
Input low / high voltage for MP+ pad	V_{ILHMP+} CC	1.1	-	1.9	V	Hysteresis inactive
Pad set-up time for MP+ pad	t_{SET_MPP} CC	-	-	100	ns	
Short circuit current for MP+ pad ⁶⁾	I_{SCMP+} SR	-10	-	10	mA	absolute max value (PSI5)
Deviation of symmetry for rising and falling edges	SYM CC	-	-	20	%	

- 1) Hysteresis is implemented to avoid metastable states and switching due to internal ground bounce. It can't be guaranteed that it suppresses switching due to external system noise.
- 2) For currents smaller than the $I_{OL/OH}$ from the test condition the defined Max. value stays unchanged.
- 3) Rise / fall times are defined 10% - 90% of $V_{EXT/FLEX}$.
- 4) $V_{IHx} = 0.27 \cdot V_{EXT/FLEX} + 0.545V$
- 5) $V_{ILx} = 0.17 \cdot V_{EXT/FLEX}$
- 6) The values are only valid if the pad is not used during operation, otherwise I_{SC} defines the limits for operation.

Table 3-13 Class MPR 5V

Parameter	Symbol	Values			Unit	Note / Test Condition
		Min.	Typ.	Max.		
Input frequency	f_{IN} SR	-	-	75	MHz	Hysteresis active
		-	-	150	MHz	Hysteresis inactive
Input Hysteresis for MPR pads ¹⁾	$HYSMPR$ CC	$0.09 \cdot V_{EXT/FLEX}$	-	-	V	AL
		$0.075 \cdot V_{EXT/FLEX}$	-	-	V	TTL
Input leakage current class MPR	I_{OZMPR} CC	-750	-	750	nA	$(0.1 \cdot V_{EXT/FLEX}) < V_{IN} < (0.9 \cdot V_{EXT/FLEX})$
		-1500	-	1500	nA	else
Pull-up current	I_{PUHMPR} CC	{30}	-	-	μA	V_{IHmin} ; AL
		{43}	-	-	μA	V_{IHmin} ; TTL
		-	-	{107}	μA	V_{ILmax} ; AL and TTL
Pull-down current	I_{PDLMPR} CC	-	-	{100}	μA	V_{IHmin} ; AL and TTL
		{46}	-	-	μA	V_{ILmax} ; AL
		{21}	-	-	μA	V_{ILmax} ; TTL

Electrical Specification 5 V / 3.3 V switchable Pads

Table 3-13 Class MPR 5V (cont'd)

Parameter	Symbol	Values			Unit	Note / Test Condition
		Min.	Typ.	Max.		
On-resistance of the MPR pad, weak driver ²⁾	$R_{DSONMPRW}$ CC	200	620	1040	Ohm	PMOS/NMOS ; $I_{OH}=0.5mA$; $I_{OL}=0.5mA$
On-resistance of the MPR pad, medium driver ²⁾	$R_{DSONMPRM}$ CC	50	155	260	Ohm	PMOS/NMOS ; $I_{OH}=2mA$; $I_{OL}=2mA$
On-resistance of the MPR pad, strong driver ²⁾	$R_{DSONMPRS}$ CC	20	55	90	Ohm	PMOS/NMOS ; $I_{OH}=8mA$; $I_{OL}=8mA$
Rise/fall time ³⁾	t_{MPR} CC	-	-	$95+2.1 \cdot C_L$	ns	$C_L \leq 50pF$; pin out driver=weak
		-	-	$200+2.9 \cdot (C_L-50)$	ns	$C_L \geq 50pF$; $C_L \leq 200pF$; pin out driver=weak
		-	-	$25+0.5 \cdot C_L$	ns	$C_L \leq 50pF$; pin out driver=medium
		-	-	$50+0.75 \cdot (C_L-50)$	ns	$C_L \geq 50pF$; $C_L \leq 200pF$; pin out driver=medium
		-	-	$9+0.16 \cdot C_L$	ns	$C_L \geq 0pF$; $C_L \leq 50pF$; edge=medium ; pin out driver=strong
		-	-	$17+0.2 \cdot (C_L-50)$	ns	$C_L \geq 50pF$; $C_L \leq 200pF$; edge=medium ; pin out driver=strong
		-	-	$4+0.16 \cdot C_L$	ns	$C_L \leq 50pF$; edge=sharp ; pin out driver=strong
		-	-	$12+0.21 \cdot (C_L-50)$	ns	$C_L \geq 50pF$; $C_L \leq 200pF$; edge=sharp ; pin out driver=strong
		-	-	5	ns	from 0.8V to 2.0V (RMII) ; $C_L=25pF$; edge=sharp ; pin out driver=strong
		-	-	4.5	ns	from $0.2 \cdot V_{EXT/FLEX}$ to $0.8 \cdot V_{EXT/FLEX}$; $C_L=15pF$; edge=sharp ; pin out driver=strong
Input high voltage, class MPR pads	V_{IHMPR} SR	$(0.73 \cdot V_{EXT/FLEX}) - 0.25$	-	-	V	Hysteresis active, AL
		2.03 ⁴⁾	-	-	V	Hysteresis active, TTL
Input low voltage, class MPR pads	V_{ILMPR} SR	-	-	$(0.52 \cdot V_{EXT/FLEX}) - 0.25$	V	Hysteresis active, AL
		-	-	0.8 ⁵⁾	V	Hysteresis active, TTL
Input low / high voltage, class MPR pads	V_{ILHMPR} SR	1.2	-	2.3	V	Hysteresis inactive

Electrical Specification 5 V / 3.3 V switchable Pads

Table 3-13 Class MPR 5V (cont'd)

Parameter	Symbol	Values			Unit	Note / Test Condition
		Min.	Typ.	Max.		
Pad set-up time	t_{SET_MPR} CC	-	-	100	ns	
Short circuit current Class MPR	I_{SC} SR	-10	-	10	mA	absolute max value (PSI5)
Deviation of symmetry for rising and falling edges	SYM CC	-	-	20	%	

- 1) Hysteresis is implemented to avoid metastable states and switching due to internal ground bounce. It can't be guaranteed that it suppresses switching due to external system noise.
- 2) For currents smaller than the $I_{OL/OH}$ from the test condition the defined Max. value stays unchanged.
- 3) Rise / fall times are defined 10% - 90% of $V_{EXT/FLEX}$.
- 4) $V_{IHx} = 0.27 * V_{EXT/FLEX} + 0.545V$
- 5) $V_{ILx} = 0.17 * V_{EXT/FLEX}$

Table 3-14 Class MPR 3.3V

Parameter	Symbol	Values			Unit	Note / Test Condition
		Min.	Typ.	Max.		
Input frequency	f_{IN} SR	-	-	50	MHz	Hysteresis active
		-	-	100	MHz	Hysteresis inactive
Input Hysteresis for MPR pads ¹⁾	$HYSMPR$ CC	$0.05 * V_{EXT/FLEX}$	-	-	V	AL and TTL
Input leakage current class MPR	I_{OZMPR} CC	-750	-	750	nA	$(0.1 * V_{EXT/FLEX}) < V_{IN} < (0.9 * V_{EXT/FLEX})$
		-1500	-	1500	nA	else
Pull-up current	I_{PUHMPR} CC	17	-	-	μA	V_{IHmin} ; AL
		19	-	-	μA	V_{IHmin} ; TTL
		-	-	75	μA	V_{ILmax} ; AL and TTL
Pull-down current	I_{PDLMPR} CC	-	-	75	μA	V_{IHmin} ; AL and TTL
		22	-	-	μA	V_{ILmax} ; AL
		11	-	-	μA	V_{ILmax} ; TTL
On-resistance of the MPR pad, weak driver ²⁾	$R_{DSONMPRW}$ CC	250	875	1500	Ohm	; NMOS/PMOS ; $I_{OH}=0.25mA$; $I_{OL}=0.25mA$
On-resistance of the MPR pad, medium driver ²⁾	$R_{DSONMPRM}$ CC	70	235	400	Ohm	; NMOS/PMOS ; $I_{OH}=1mA$; $I_{OL}=1mA$
On-resistance of the MPR pad, strong driver ²⁾	$R_{DSONMPRS}$ CC	20	75	130	Ohm	PMOS/NMOS ; $I_{OH}=4mA$; $I_{OL}=4mA$

Electrical Specification 5 V / 3.3 V switchable Pads

Table 3-14 Class MPR 3.3V (cont'd)

Parameter	Symbol	Values			Unit	Note / Test Condition
		Min.	Typ.	Max.		
Rise/fall time ³⁾	$t_{MPR\ CC}$	-	-	$150+3.4 \cdot C_L$	ns	$C_L \leq 50\text{pF}$; pin out driver=weak
		-	-	$320+4.5 \cdot (C_L-50)$	ns	$C_L \geq 50\text{pF}$; $C_L \leq 200\text{pF}$; pin out driver=weak
		-	-	$30+0.8 \cdot C_L$	ns	$C_L \leq 50\text{pF}$; pin out driver=medium
		-	-	$70+1.1 \cdot (C_L-50)$	ns	$C_L \geq 50\text{pF}$; $C_L \leq 200\text{pF}$; pin out driver=medium
		-	-	$20+0.2 \cdot C_L$	ns	$C_L \geq 0\text{pF}$; $C_L \leq 50\text{pF}$; edge=medium; pin out driver=strong
		-	-	$30+0.3 \cdot (C_L-50)$	ns	$C_L \geq 50\text{pF}$; $C_L \leq 200\text{pF}$; edge=medium; pin out driver=strong
		-	-	$13+0.2 \cdot C_L$	ns	$C_L \leq 50\text{pF}$; edge=sharp; pin out driver=strong
		-	-	$23+0.3 \cdot (C_L-50)$	ns	$C_L \geq 50\text{pF}$; $C_L \leq 200\text{pF}$; edge=sharp; pin out driver=strong
		-	-	5	ns	from 0.8V to 2.0V (RMII); $C_L=25\text{pF}$; edge=sharp; pin out driver=strong
		-	-	4.5	ns	from $0.2 \cdot V_{EXT/FLEX}$ to $0.8 \cdot V_{EXT/FLEX}$; $C_L=15\text{pF}$; edge=sharp; pin out driver=strong
Input high voltage, class MPR pads	$V_{IHMPR\ SR}$	$(0.73 \cdot V_{EX\ T/FLEX}) - 0.25$	-	-	V	Hysteresis active, AL
		1.6 ⁴⁾	-	-	V	Hysteresis active, TTL
Input low voltage, class MPR pads	$V_{ILMPR\ SR}$	-	-	$(0.52 \cdot V_{EX\ T/FLEX}) - 0.25$	V	Hysteresis active, AL
		-	-	0.5 ⁵⁾	V	Hysteresis active, TTL
Input low / high voltage, class MPR pads	$V_{ILHMPR\ SR}$	0.8	-	1.7	V	Hysteresis inactive
Pad set-up time	$t_{SET_MPR\ CC}$	-	-	100	ns	
Short circuit current Class MPR	$I_{SC\ SR}$	-10	-	10	mA	absolute max value (PSI5)

1) Hysteresis is implemented to avoid metastable states and switching due to internal ground bounce. It can't be guaranteed that it suppresses switching due to external system noise.

2) For currents smaller than the $I_{OL/OH}$ from the test condition the defined Max. value stays unchanged.

Electrical Specification 5 V / 3.3 V switchable Pads

- 3) Rise / fall times are defined 10% - 90% of $V_{EXT/FLEX}$.
- 4) $V_{IHx} = 0.27 * V_{EXT/FLEX} + 0.545V$
- 5) $V_{ILx} = 0.17 * V_{EXT/FLEX}$

Table 3-15 Class S

Parameter	Symbol	Values			Unit	Note / Test Condition
		Min.	Typ.	Max.		
Input frequency	f_{IN} SR	-	-	75	MHz	Hysteresis active
		-	-	150	MHz	Hysteresis inactive
Input Hysteresis for S pad ¹⁾	HYS_S CC	0.3	-	-	V	
Pull-up current for S pad	I_{PUHS} CC	30	-	-	μA	V_{IHmin}
		-	-	107	μA	V_{ILmax}
Pull-down current for S pad	I_{PDL_S} CC	-	-	100	μA	V_{IHmin}
		46	-	-	μA	V_{ILmax}
Input Leakage current Class S	I_{OZS} CC	-350	-	350	nA	Analog Inputs with pull down diagnostics
		-150	-	150	nA	else
Input voltage high for S pad	V_{IHS} SR	-	-	$(0.73 * V_{DD_M}) - 0.25$	V	Hysteresis active
Input voltage low for S pad	V_{ILS} SR	$(0.52 * V_{DD_M}) - 0.25$	-	-	V	Hysteresis active
Input low threshold variation for S pad ²⁾	V_{ILSD} SR	-50	-	50	mV	max. variation of 1ms; $V_{DDM} = \text{constant}$
Input capacitance for S pad	C_{INS} CC	-	-	10	pF	
Pad set-up time for S pad	t_{SETS} CC	-	-	100	ns	

- 1) Hysteresis is implemented to avoid metastable states and switching due to internal ground bounce. It can't be guaranteed that it suppresses switching due to external system noise.
- 2) V_{ILSD} is implemented to ensure J2716 specification. For details of dedicated pins please see AP32286 for details.

Table 3-16 Class I 5V

Parameter	Symbol	Values			Unit	Note / Test Condition
		Min.	Typ.	Max.		
Input frequency	f_{IN} SR	-	-	75	MHz	Hysteresis active
		-	-	150	MHz	Hysteresis inactive
Input Hysteresis for I pad ¹⁾	HYS_I CC	$0.07 * V_{EXT/FLEX}$	-	-	V	\overline{PORST} pad only
		$0.09 * V_{EXT/FLEX}$	-	-	V	AL
		$0.075 * V_{EXT/FLEX}$	-	-	V	TTL
Pull-up current for I pad	I_{PUHI} CC	30	-	-	μA	V_{IHmin} ; AL
		43	-	-	μA	V_{IHmin} ; TTL
		-	-	107	μA	V_{ILmax} ; AL and TTL

Electrical Specification 5 V / 3.3 V switchable Pads

Table 3-16 Class I 5V (cont'd)

Parameter	Symbol	Values			Unit	Note / Test Condition
		Min.	Typ.	Max.		
Pull-down current for I pad	I_{PDLI} CC	-	-	100	μ A	V_{IHmin} : AL and TTL
		46	-	-	μ A	V_{ILmax} : AL
		21	-	-	μ A	V_{ILmax} : TTL
Input Leakage Current for I pad	I_{OZI} CC	-150	-	150	nA	$(0.1 \cdot V_{EXT/FLEX}) < V_{IN} < (0.9 \cdot V_{EXT/FLEX})$
		-350	-	350	nA	else
Input high voltage for I pad	V_{IHI} SR	2.03 ²⁾	-	-	V	Hysteresis active, TTL
		$(0.73 \cdot V_{EXT/FLEX}) - 0.25$	-	-	V	Hysteresis active; AL; not available for the \overline{PORST} pad
Input low voltage for I pad	V_{ILI} SR	-	-	0.8 ³⁾	V	Hysteresis active, TTL
		-	-	$(0.52 \cdot V_{EXT/FLEX}) - 0.25$	V	Hysteresis active; AL; not available for the \overline{PORST} pad
Input low / high voltage for I pad	V_{ILHI} CC	1.85	-	3.0	V	Hysteresis inactive
Pad set-up time for I pad	t_{SETI} CC	-	-	100	ns	

1) Hysteresis is implemented to avoid metastable states and switching due to internal ground bounce. It can't be guaranteed that it suppresses switching due to external system noise.

2) $V_{IHx} = 0.27 \cdot V_{EXT/FLEX} + 0.545V$

3) $V_{ILx} = 0.17 \cdot V_{EXT/FLEX}$

Table 3-17 Class I 3.3V

Parameter	Symbol	Values			Unit	Note / Test Condition
		Min.	Typ.	Max.		
Input frequency	f_{IN} SR	-	-	50	MHz	Hysteresis active
		-	-	100	MHz	Hysteresis inactive
Input Hysteresis for I pad ¹⁾	$HYSI$ CC	$0.045 \cdot V_{EXT/FLEX}$	-	-	V	\overline{PORST} pad only
		$0.05 \cdot V_{EXT/FLEX}$	-	-	V	AL and TTL
Pull-up current for I pad	I_{PUHI} CC	17	-	-	μ A	V_{IHmin} : AL
		19	-	-	μ A	V_{IHmin} : TTL
		-	-	75	μ A	V_{ILmax} : AL and TTL
Pull-down current for I pad	I_{PDLI} CC	-	-	75	μ A	V_{IHmin} : AL and TTL
		22	-	-	μ A	V_{ILmax} : AL
		11	-	-	μ A	V_{ILmax} : TTL
Input Leakage Current for I pad	I_{OZI} CC	-150	-	150	nA	$(0.1 \cdot V_{EXT/FLEX}) < V_{IN} < (0.9 \cdot V_{EXT/FLEX})$
		-350	-	350	nA	else

Electrical Specification 5 V / 3.3 V switchable Pads

Table 3-17 Class I 3.3V (cont'd)

Parameter	Symbol	Values			Unit	Note / Test Condition
		Min.	Typ.	Max.		
Input high voltage for I pad	V_{IHI} SR	1.6 ²⁾	-	-	V	Hysteresis active, TTL
		$(0.73 * V_{EX} - 0.25)$ ^{T/FLEX)}	-	-	V	Hysteresis active; AL; not available for the \overline{PORST} pad
Input low voltage for I pad	V_{ILI} SR	-	-	0.5 ³⁾	V	Hysteresis active, TTL
		-	-	$(0.52 * V_{EX} - 0.25)$ ^{T/FLEX)}	V	Hysteresis active; AL; not available for the \overline{PORST} pad
Input low / high voltage for I pad	V_{ILHI} CC	1.1	-	1.9	V	Hysteresis inactive
Pad set-up time for I pad	t_{SETI} CC	-	-	100	ns	

- 1) Hysteresis is implemented to avoid metastable states and switching due to internal ground bounce. It can't be guaranteed that it suppresses switching due to external system noise.
- 2) $V_{IHx} = 0.27 * V_{EXT/FLEX} + 0.545V$
- 3) $V_{ILx} = 0.17 * V_{EXT/FLEX}$

Table 3-18 Driver Mode Selection for LP Pads

PDx.2	PDx.1	PDx.0	Port Functionality	Driver Setting
X	X	0	Speed grade 1	medium (LPm)
X	X	1	Speed grade 2	weak (LPw)

Table 3-19 Driver Mode Selection for MP / MP+ Pads

PDx.2	PDx.1	PDx.0	Port Functionality	Driver Setting
X	0	0	Speed grade 1	Strong sharp edge (MPss / MP+ss / MPRss)
X	0	1	Speed grade 2	Strong medium edge (MPsm / MP+sm / MPRsm)
X	1	0	Speed grade 3	medium (MPm / MP+m / MPRm)
X	1	1	Speed grade 4	weak (MPw / MP+w / MPRw)

3.6 3.3 V only Pads

Pad classes LP, MP and MP+ support both Automotive Level (AL) or TTL level (TTL) operation. Parameters are defined for AL operation and degrade in TTL operation.

Table 3-20 Class A2

Parameter	Symbol	Values			Unit	Note / Test Condition
		Min.	Typ.	Max.		
Input frequency	f_{IN} SR	-	-	160	MHz	
Input Hysteresis for A2 pad ¹⁾	HYS_{A2} CC	0.1 * V_{DDP3}	-	-	V	TTL; else
		0.06 * V_{DDP3}	-	-	V	valid for P21.6 and P21.7
Input Leakage current for A2 pad	I_{OZA2} CC	-300	-	300	nA	$(0.1 * V_{EXT/FLEX}) < V_{IN} < (0.9 * V_{EXT/FLEX})$
		-800	-	500	nA	else
Pull-up current for A2 pad	I_{PUHA2} CC	-	-	100	μ A	V_{IHmin}
		25	-	-	μ A	V_{ILmax}
Pull-down current for A2 pad	I_{PDLA2} CC	23	-	-	μ A	V_{IHmin}
		-	-	100	μ A	V_{ILmax}
On-Resistance for A2 pad, weak driver ²⁾	$R_{DSONA2W}$ CC	100	200	325	Ohm	PMOS/NMOS ; $I_{OH}=0.5mA; I_{OL}=0.5mA$
On-Resistance for A2 pad, medium driver ²⁾	$R_{DSONA2M}$ CC	40	70	100	Ohm	PMOS/NMOS ; $I_{OH}=2mA; I_{OL}=2mA$
On-Resistance for A2 pad, strong driver ²⁾	$R_{DSONA2S}$ CC	20	35	50	Ohm	PMOS/NMOS ; $I_{OH}=8mA; I_{OL}=8mA$
Rise/fall time for A2 pad ³⁾	t_{A2} CC	-	-	$20+0.8 * C_L$	ns	$C_L \leq 50pF$; pin out driver=weak
		-	-	$17.5+0.85 * C_L$	ns	$C_L \geq 50pF; C_L \leq 200pF$; pin out driver=weak
		-	-	$12+0.16 * C_L$	ns	$C_L \leq 50pF$; pin out driver=medium
		-	-	$11.5+0.17 * C_L$	ns	$C_L \geq 50pF; C_L \leq 200pF$; pin out driver=medium
		-	-	$6+0.06 * C_L$	ns	$C_L \leq 50pF$; edge=medium ; pin out driver=strong
		-	-	$5.5+0.07 * C_L$	ns	$C_L \geq 50pF; C_L \leq 200pF$; edge=medium ; pin out driver=strong
		-	-	$0.0+0.12 * C_L$	ns	$C_L \leq 50pF$; edge=sharp ; pin out driver=strong
		-	-	$0.0+0.12 * C_L$	ns	$C_L \geq 50pF; C_L \leq 200pF$; edge=sharp ; pin out driver=strong

Table 3-20 Class A2 (cont'd)

Parameter	Symbol	Values			Unit	Note / Test Condition
		Min.	Typ.	Max.		
Input high voltage for A2 pad	V_{IHA2} SR	2.04 ⁴⁾	-	-	V	TTL; valid for all A2 pads except TMS/DAP1, TRST, and TCK/DAP0
		0.7 * V_{DDP3}	-	-	V	valid for TMS/DAP1, TRST, and TCK/DAP0
Input low voltage for A2 pad	V_{ILA2} SR	-	-	0.8 ⁵⁾	V	TTL; valid for all A2 pads except TMS/DAP1, TRST, and TCK/DAP0
		-	-	0.3 * V_{DDP3}	V	valid for TMS/DAP1, TRST, and TCK/DAP0
Pad set-up time for A2 pad	t_{SETA2} CC	-	-	100	ns	
Deviation of symmetry for rising and falling edges	SYM CC	-	-	20	%	

- 1) Hysteresis is implemented to avoid metastable states and switching due to internal ground bounce. It can't be guaranteed that it suppresses switching due to external system noise.
- 2) For currents smaller than the $I_{OL/OH}$ from the test condition the defined Max. value stays unchanged.
- 3) Rise / fall times are defined 10% - 90% of V_{DDP3} .
- 4) $V_{IHx} = 0.57 * V_{DDP3} - 0.03V$
- 5) $V_{ILx} = 0.25 * V_{DDP3} + 0.058V$

Table 3-21 Driver Mode Selection for A2 Pads

PDx.2	PDx.1	PDx.0	Port Functionality	Driver Setting
X	0	0	Speed grade 1	Strong sharp edge
X	0	1	Speed grade 2	Strong medium edge
X	1	0	Speed grade 3	medium
X	1	1	Speed grade 4	weak

Table 3-22 Driver Mode Selection for F Pads

PDx.2	PDx.1	PDx.0	Port Functionality	Driver Setting
X	0	0	Speed grade 1	Reduced Strong sharp edge
X	0	1	Speed grade 2	Reduced Strong medium edge
X	1	0	Speed grade 3	medium
X	1	1	Speed grade 4	weak

3.7 High performance LVDS Pads (LVDSH)

This LVDS pad type is used for the high speed chip to chip communication interface of the new TC 260 / 264 / 265 / 267. It compose out of a LVDSH pad and a Class F pad.

This pad combination is always supplied by the 3.3V supply rail.

Table 3-23 Class F

Parameter	Symbol	Values			Unit	Note / Test Condition
		Min.	Typ.	Max.		
Input frequency	f_{IN} SR	-	-	75	MHz	
Input Hysteresis for F pad ¹⁾	$HYSF$ CC	0.1 * V_{DDP3}	-	-	V	TTL
Input Leakage Current for F pad	I_{OZF} CC	-1000	-	1000	nA	$(0.1 * V_{DDP3}) < V_{IN} < (0.9 * V_{DDP3})$; valid for P21.2 and P21.3; $T_J = 150^\circ\text{C}$
		-1500	-	1500	nA	$(0.1 * V_{DDP3}) < V_{IN} < (0.9 * V_{DDP3})$; valid for P21.2 and P21.3; $T_J = 170^\circ\text{C}$
		-300	-	300	nA	$(0.1 * V_{DDP3}) < V_{IN} < (0.9 * V_{DDP3})$; valid for P21.4 and P21.5
		-2000	-	2000	nA	else; valid for P21.2 and P21.3; $T_J = 150^\circ\text{C}$
		-3000	-	3000	nA	else; valid for P21.2 and P21.3; $T_J = 170^\circ\text{C}$
		-600	-	600	nA	else; valid for P21.4 and P21.5
Pull-up current for F pad	I_{PUHF} CC	25	-	-	μA	V_{IHmin}
		-	-	100	μA	V_{ILmax}
Pull-down current for class F pads	I_{PDLF} CC	-	-	100	μA	V_{IHmin}
		25	-	-	μA	V_{ILmax}
On resistance for F pad, weak driver ²⁾	R_{DSONFW} CC	100	200	325	Ohm	PMOS/NMOS ; $I_{OH}=0.5\text{mA}$; $I_{OL}=0.5\text{mA}$
On resistance for F pad, medium driver ²⁾	R_{DSONFM} CC	40	70	100	Ohm	PMOS/NMOS ; $I_{OH}=2\text{mA}$; $I_{OL}=2\text{mA}$
On resistance for F pad, strong driver ²⁾	R_{DSONFS} CC	20	50	80	Ohm	PMOS/NMOS ; $I_{OH}=4\text{mA}$; $I_{OL}=4\text{mA}$

Electrical Specification High performance LVDS Pads (LVDSH)

Table 3-23 Class F (cont'd)

Parameter	Symbol	Values			Unit	Note / Test Condition
		Min.	Typ.	Max.		
Rise/fall time for F pad ³⁾	$t_{\text{rff}} \text{ CC}$	-	-	$20+0.8 \cdot C_L$	ns	$C_L \leq 50\text{pF}$; pin out driver=weak
		-	-	$17.5+0.85 \cdot C_L$	ns	$C_L \geq 50\text{pF}$; $C_L \leq 200\text{pF}$; pin out driver=weak
		-	-	$12+0.16 \cdot C_L$	ns	$C_L \leq 50\text{pF}$; pin out driver=medium
		-	-	$11.5+0.17 \cdot C_L$	ns	$C_L \geq 50\text{pF}$; $C_L \leq 200\text{pF}$; pin out driver=medium
		-	-	$7+0.16 \cdot C_L$	ns	$C_L \leq 50\text{pF}$; edge=medium; pin out driver=reduced strong
		-	-	$6.5+0.17 \cdot C_L$	ns	$C_L \geq 50\text{pF}$; $C_L \leq 200\text{pF}$; edge=medium; pin out driver>reduced strong
		-	-	$4+0.16 \cdot C_L$	ns	$C_L \leq 50\text{pF}$; edge=sharp; pin out driver=reduced strong
		-	-	$3.5+0.17 \cdot C_L$	ns	$C_L \geq 50\text{pF}$; $C_L \leq 200\text{pF}$; edge=sharp; pin out driver=reduced strong
Input high voltage for F pad	$V_{\text{IHF}} \text{ SR}$	2.04 ⁴⁾	-	-	V	TTL
Input low voltage for F pad	$V_{\text{ILF}} \text{ SR}$	-	-	0.8 ⁵⁾	V	TTL
Pad set-up time for F pad	$t_{\text{SETF}} \text{ CC}$	-	-	100	ns	
Deviation of symmetry for rising and falling edges	$SYM \text{ CC}$	-	-	20	%	

1) Hysteresis is implemented to avoid metastable states and switching due to internal ground bounce. It can't be guaranteed that it suppresses switching due to external system noise.

2) For currents smaller than the $I_{\text{OL/OH}}$ from the test condition the defined Max. value stays unchanged.

3) Rise / fall times are defined 10% - 90% of V_{DDP3} .

4) $V_{\text{IHx}} = 0.57 \cdot V_{\text{DDP3}} - 0.03\text{V}$

5) $V_{\text{ILx}} = 0.25 \cdot V_{\text{DDP3}} + 0.058\text{V}$

$C_L = 2.5 \text{ pF}$ for all LVDSH parameters.

Table 3-24 LVDSH - IEEE standard LVDS general purpose link (GPL)

Parameter	Symbol	Values			Unit	Note / Test Condition
		Min.	Typ.	Max.		
Output impedance	$R_0 \text{ CC}$	40	-	140	Ohm	$V_{\text{cm}} = 1.0 \text{ V}$ and 1.4 V
Rise time ¹⁾	$t_{\text{rise20}} \text{ CC}$	-	-	0.5	ns	$Z_L = 100 \text{ Ohm} \pm 5\%$ @2 pF
Fall time ¹⁾	$t_{\text{fall20}} \text{ CC}$	-	-	0.5	ns	$Z_L = 100 \text{ Ohm} \pm 5\%$ @ 2 pF
Output differential voltage	$V_{\text{OD}} \text{ CC}$	250	-	400	mV	$RT = 100 \text{ Ohm} \pm 5\%$

Electrical Specification High performance LVDS Pads (LVDSH)

Table 3-24 LVDSH - IEEE standard LVDS general purpose link (GPL) (cont'd)

Parameter	Symbol	Values			Unit	Note / Test Condition
		Min.	Typ.	Max.		
Output voltage high	V_{OH} CC	-	-	1475	mV	RT = 100 Ohm \pm 5% (400 mV/2) + 1275 mV
Output voltage low	V_{OL} CC	925	-	-	mV	RT = 100 Ohm \pm 5%
Output offset (Common mode) voltage	V_{OS} CC	1125	-	1275	mV	RT = 100 Ohm \pm 5%
Input voltage range	V_I SR	0	-	1600	mV	Driver ground potential difference < 925 mV; RT = 100 Ohm \pm 10%
		0	-	2000	mV	Driver ground potential difference < 925 mV; RT = 100 Ohm \pm 20%
Input differential threshold	V_{idth} SR	-100	-	100	mV	Driver ground potential difference < 925 mV
Delta output impedance	dR_O SR	-	-	10	%	V_{cm} = 1.0 V and 1.4 V (mismatch Pd and Pn)
Change in VOS between 0 and 1	dV_{OS} CC	-	-	25	mV	RT = 100 Ohm \pm 5%
Change in Vod between 0 and 1	dV_{od} CC	-	-	25	mV	RT = 100 Ohm \pm 5%
Duty cycle	t_{duty} CC	45	-	55	%	

 1) Rise / fall times are defined for 20% - 80% of V_{OD}

Table 3-25 LVDSH - IEEE standard LVDS reduced link (REDL)

Parameter	Symbol	Values			Unit	Note / Test Condition
		Min.	Typ.	Max.		
Output impedance	R_O CC	40	-	140	Ohm	V_{cm} = 1.0 V and 1.4 V
Output differential voltage	V_{OD} CC	150	-	250	mV	RT = 100 Ohm \pm 5%
Output voltage high	V_{OH} CC	-	-	1375	mV	RT = 100 Ohm \pm 5%
Output voltage low	V_{OL} CC	1025	-	-	mV	RT = 100 Ohm \pm 5%
Output offset (Common mode) voltage	V_{OS} CC	1125	-	1275	mV	RT = 100 Ohm \pm 5%
Input voltage range	V_I SR	825	-	1575	mV	Driver ground potential difference < 50 mV
Input differential threshold	V_{idth} SR	-100	-	100	mV	Driver ground potential difference < 50 mV
Change in VOS between 0 and 1	dV_{OS} CC	-	-	25	mV	RT = 100 Ohm \pm 5%
Change in Vod between 0 and 1	dV_{od} CC	-	-	25	mV	RT = 100 Ohm \pm 5%
Duty cycle	t_{duty} CC	45	-	55	%	

Electrical Specification High performance LVDS Pads (LVDSH)

Table 3-25 LVDSH - IEEE standard LVDS reduced link (REDL) (cont'd)

Parameter	Symbol	Values			Unit	Note / Test Condition
		Min.	Typ.	Max.		
V_{OD} Fall time ¹⁾	t_{fall10} CC	-	-	0.5	ns	ZL = 100 Ohm \pm 5% @ 2pF
V_{OD} Rise time ¹⁾	t_{rise10} CC	-	-	0.5	ns	ZL = 100 Ohm \pm 5% @ 2pF

1) Rise / fall times are defined for 10% - 90% of V_{OD}

default after start-up = CMOS function

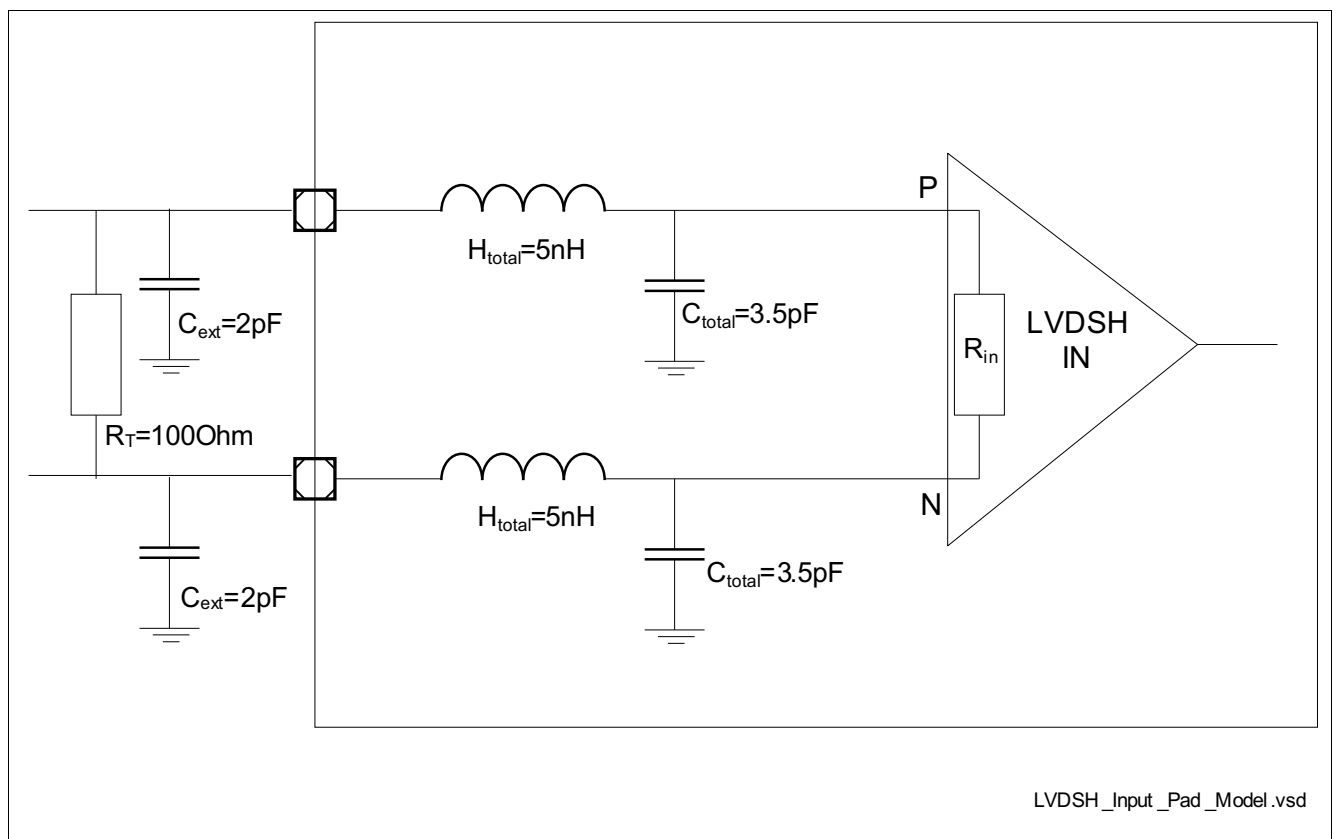

Figure 3-1 LVDSH pad Input model

3.8 Medium performance LVDS Pads (LVDSM)

This LVDS pad type is used for the medium speed chip to chip communication interface of the new TC 260 / 264 / 265 / 267. It compose out of a LVDSM pad and a MP pad.

This pad combination is always supplied by the 5V or 3.3V.

For the parameters of the MP pad please see [Chapter 3.5](#).

Table 3-26 LVDSM

Parameter	Symbol	Values			Unit	Note / Test Condition
		Min.	Typ.	Max.		
Output impedance	R_O CC	40	100	140	Ohm	
Fall time	t_F CC	-	-	2.5	ns	$Z_{load} = 100$ Ohm; termination 100 Ohm $\pm 1\%$
Rise time	t_R CC	-	-	2.5	ns	$Z_{load} = 100$ Ohm; termination 100 Ohm $\pm 1\%$
Pad set-up time	t_{SET_LVDS} CC	-	10	13	μs	
Output Differential Voltage	V_{OD} CC	250	-	400	mV	termination 100 Ohm $\pm 1\%$
Output voltage high	V_{OH} CC	-	-	1475	mV	termination 100 Ohm $\pm 1\%$
Output voltage low	V_{OL} CC	925	-	-	mV	termination 100 Ohm $\pm 1\%$
Output Offset Voltage	V_{OS} CC	1125	-	1275	mV	termination 100 Ohm $\pm 1\%$

default after start-up = CMOS function

3.9 VADC Parameters

VADC parameter are valid for $V_{DDM} = 4.5 \text{ V}$ to 5.5 V .

This tables also covers the parameters for Class D pads.

Table 3-27 VADC

Parameter	Symbol	Values			Unit	Note / Test Condition
		Min.	Typ.	Max.		
Analog reference voltage ¹⁾	V_{AREF} SR	$V_{AGND} + 1.0$	-	$V_{DDM} + 0.05$	V	
Analog reference ground	V_{AGND} SR	$V_{SSM} - 0.05$	-	$V_{SSM} + 0.05$	V	
Analog input voltage range	V_{AIN} SR	V_{AGND}	-	V_{AREF}	V	
Converter reference clock	f_{ADCI} SR	2	-	20	MHz	
Charge consumption per conversion ^{2) 3)}	Q_{CONV} CC	-	50	75	pC	$V_{AIN} = 5 \text{ V}$, charge consumed from reference pin, precharging disabled
		-	10	22	pC	$V_{AIN} = 5 \text{ V}$, charge consumed from reference pin, precharging enabled
Conversion time for 12-bit result	t_{C12} CC	-	$(16 + \text{STC}) \times t_{ADCI} + 2 \times t_{VADC}$	-		Includes sample time and post calibration
Conversion time for 10-bit result	t_{C10} CC	-	$(14 + \text{STC}) \times t_{ADCI} + 2 \times t_{VADC}$	-		Includes sample time
Conversion time for 8-bit result	t_{C8} CC	-	$(12 + \text{STC}) \times t_{ADCI} + 2 \times t_{VADC}$	-		Includes sample time
Conversion time for fast compare mode	t_{CF} CC	-	$(4 + \text{STC}) \times t_{ADCI} + 2 \times t_{VADC}$	-		Includes sample time
Broken wire detection delay against V_{AGND} ⁴⁾	t_{BWG} CC	-	-	120	cycles	Result below 10%
Broken wire detection delay against V_{AREF} ⁵⁾	t_{BWR} CC	-	-	60	cycles	Result above 80%
Input leakage at analog inputs	I_{OZ1} CC	-350	-	350	nA	Analog Inputs overlaid with class LP pads or pull down diagnostics
		-150	-	150	nA	else
Total Unadjusted Error ¹⁾	TUE CC	-4 ⁶⁾	-	4 ⁶⁾	LSB	12-bit resolution

Electrical Specification VADC Parameters

Table 3-27 VADC (cont'd)

Parameter	Symbol	Values			Unit	Note / Test Condition
		Min.	Typ.	Max.		
INL Error	EA_{INL} CC	-3	-	3	LSB	12-bit resolution
Gain Error ¹⁾	EA_{GAIN} CC	-3.5	-	3.5	LSB	12-bit resolution
DNL error ¹⁾	EA_{DNL} CC	-3	-	3	LSB	12-bit resolution
Offset Error ¹⁾	EA_{OFF} CC	-4	-	4	LSB	12-bit resolution
Total capacitance of an analog input	C_{AINT} CC	-	-	30	pF	
Switched capacitance of an analog input	C_{AINS} CC	2	4	7	pF	
Resistance of the analog input path	R_{AIN} CC	-	-	1.5	kOhm	else
		-	-	1.8	kOhm	valid for analog inputs mapped to GPIOs
Switched capacitance of a reference input	C_{AREFS} CC	-	-	30	pF	
RMS Noise ⁷⁾	EN_{RMS} CC	-	0.5	0.8 ⁶⁾⁸⁾	LSB	
Positive reference V_{AREFX} pin leakage	I_{OZ2} CC	-2	-	2	μ A	$V_{AREFX} = V_{AREF1}$; $V_{AREF} \leq V_{DDM}V$; $T_J \leq 150^\circ C$
		-3	-	3	μ A	$V_{AREFX} = V_{AREF1}$; $V_{AREF} \leq V_{DDM}V$; $T_J > 150^\circ C$
		-4	-	4	μ A	$V_{AREFX} = V_{AREF1}$; $V_{AREF} > V_{DDM}V$; $T_J \leq 150^\circ C$
		-7	-	7	μ A	$V_{AREFX} = V_{AREF1}$; $V_{AREF} > V_{DDM}V$; $T_J > 150^\circ C$
Negative reference V_{AGNDx} pin leakage	I_{OZ3} CC	-13	-	13	μ A	$V_{AGNDx} = V_{AGND1}$; $V_{AGND} < V_{SSM}$; $T_J > 150^\circ C$
		-7	-	7	μ A	$V_{AGNDx} = V_{AGND1}$; $V_{AGND} < V_{SSM}$; $T_J \leq 150^\circ C$
		-3	-	3	μ A	$V_{AGNDx} = V_{AGND1}$; $V_{AGND} \geq V_{SSM}$; $T_J > 150^\circ C$
		-2.5	-	2.5	μ A	$V_{AGNDx} = V_{AGND1}$; $V_{AGND} \geq V_{SSM}$; $T_J \leq 150^\circ C$
Resistance of the reference input path	R_{AREF} CC	-	-	1	kOhm	
CSD resistance ⁹⁾	R_{CSD} CC	-	-	28	kOhm	

Electrical Specification VADC Parameters

Table 3-27 VADC (cont'd)

Parameter	Symbol	Values			Unit	Note / Test Condition
		Min.	Typ.	Max.		
Resistance of the multiplexer diagnostics pull-down device	R_{MDD} CC	$25 + 1 \cdot V_{IN}$	-	$35 + 8 \cdot V_{IN}$	kOhm	$0 \text{ V} \leq V_{IN} \leq 2.5 \text{ V}$
		$-5 + 13 \cdot V_{IN}$	-	$15 + 16 \cdot V_{IN}$	kOhm	$2.5 \text{ V} \leq V_{IN} \leq V_{DDM}$
Resistance of the multiplexer diagnostics pull-up device	R_{MDU} CC	$45 - 6 \cdot V_{IN}$	-	$90 - 16 \cdot V_{IN}$	kOhm	$0 \text{ V} \geq V_{IN} \leq 2.5 \text{ V}$
		$40 - 4 \cdot V_{IN}$	-	$65 - 6 \cdot V_{IN}$	kOhm	$2.5 \text{ V} \leq V_{IN} \leq V_{DDM}$
Resistance of the pull-down test device ¹⁰⁾	R_{PDD} CC	-	-	0.3	kOhm	
CSD voltage accuracy ^{11) 12)}	$dVCSD$ CC	-	-	10	%	
Wakeup time	t_{WU} CC	-	-	12	μs	

- 1) If the reference voltage is reduced by the factor k ($k < 1$), TUE, DNL, INL, Gain, and Offset errors increase also by the factor $1/k$. V_{AREF} must be decoupled with an external capacitor.
- 2) For $QCONV = X \text{ pC}$ and a conversion time of $1 \mu\text{s}$ a rms value of $X \mu\text{A}$ results for I_{AREFX} .
- 3) For the details of the mapping for a VADC group to pin V_{AREFX} please see the User's Manual.
- 4) The broken wire detection delay against V_{AGND} is measured in numbers of consecutive precharge cycles at a conversion rate higher than 1 conversion per 500 ms.
- 5) The broken wire detection delay against V_{AREF} is measured in numbers of consecutive precharge cycles at a conversion rate higher than 1 conversion per 10 ms. This function is influenced by leakage current, in particular at high temperature.
- 6) Resulting worst case combined error is arithmetic combination of TUE and EN_{RMS} .
- 7) This parameter is valid for soldered devices and requires careful analog board design.
- 8) Value is defined for one sigma Gauss distribution.
- 9) In order to avoid an additional error due to incomplete sampling, the sampling time shall be set greater than $5 \cdot R_{CSD} \cdot C_{AINS}$.
- 10) The pull-down resistor R_{PDD} is connected between the input pad and the analog multiplexer. The input pad itself adds another 200-Ohm series resistance, when measuring through the pin.
- 11) CSD: Converter Self Diagnostics, for details please consult the User's Manual.
- 12) Note, that in case CSD voltage is chosen to nom. 1/3 or 2/3 of V_{AREF} voltage, the reference voltage is loaded with a current of max. $V_{AREF} / 45 \text{ kOhm}$.

The following VADC parameter are valid for $V_{DDM} = 2.97 \text{ V}$ to 4.5 V .

Table 3-28 VADC_33V

Parameter	Symbol	Values			Unit	Note / Test Condition
		Min.	Typ.	Max.		
Analog reference voltage ¹⁾	V_{AREF} SR	$V_{AGND} + 1.0$	-	$V_{DDM} + 0.05$	V	
Analog reference ground	V_{AGND} SR	$V_{SSM} - 0.05$	-	$V_{SSM} + 0.05$	V	
Analog input voltage range	V_{AIN} SR	V_{AGND}	-	V_{AREF}	V	
Converter reference clock	f_{ADCI} SR	2	-	20	MHz	

Electrical Specification VADC Parameters

Table 3-28 VADC_33V (cont'd)

Parameter	Symbol	Values			Unit	Note / Test Condition
		Min.	Typ.	Max.		
Charge consumption per conversion ^{2) 3)}	Q_{CONV} CC	-	35	50	pC	$V_{AIN} = 3.3$ V, charge consumed from reference pin, precharging disabled
		-	8	17	pC	$V_{AIN} = 3.3$ V, charge consumed from reference pin, precharging enabled
Conversion time for 12-bit result	t_{C12} CC	-	$(16 + \text{STC}) \times t_{ADCI} + 2 \times t_{VADC}$	-		Includes sample time and post calibration
Conversion time for 10-bit result	t_{C10} CC	-	$(14 + \text{STC}) \times t_{ADCI} + 2 \times t_{VADC}$	-		Includes sample time
Conversion time for 8-bit result	t_{C8} CC	-	$(12 + \text{STC}) \times t_{ADCI} + 2 \times t_{VADC}$	-		Includes sample time
Conversion time for fast compare mode	t_{CF} CC	-	$(4 + \text{STC}) \times t_{ADCI} + 2 \times t_{VADC}$	-		Includes sample time
Broken wire detection delay against V_{AGND} ⁴⁾	t_{BWG} CC	-	-	120	cycles	Result below 10%
Broken wire detection delay against V_{AREF} ⁵⁾	t_{BWR} CC	-	-	60	cycles	Result above 80%
Input leakage at analog inputs	I_{OZ1} CC	-350	-	350	nA	Analog Inputs overlaid with class LP pads or pull down diagnostics
		-150	-	150	nA	else
Total Unadjusted Error ¹⁾	TUE CC	-12 ⁶⁾	-	12 ⁶⁾	LSB	12-bit Resolution; $T_J > 150$ °C
		-6 ⁶⁾	-	6 ⁶⁾	LSB	12-bit Resolution; $T_J \leq 150$ °C
INL Error	EA_{INL} CC	-12	-	12	LSB	12-bit Resolution; $T_J > 150$ °C
		-5	-	5	LSB	12-bit Resolution; $T_J \leq 150$ °C
Gain Error ¹⁾	EA_{GAIN} CC	-6	-	6	LSB	12-bit Resolution; $T_J > 150$ °C
		-5.5	-	5.5	LSB	12-bit Resolution; $T_J \leq 150$ °C

Electrical Specification VADC Parameters

Table 3-28 VADC_33V (cont'd)

Parameter	Symbol	Values			Unit	Note / Test Condition
		Min.	Typ.	Max.		
DNL error ¹⁾	EA_{DNL} CC	-4	-	4	LSB	12-bit resolution
Offset Error ¹⁾	EA_{OFF} CC	-6	-	6	LSB	12-bit Resolution; $T_J > 150^\circ\text{C}$
		-5	-	5	LSB	12-bit Resolution; $T_J \leq 150^\circ\text{C}$
Total capacitance of an analog input	C_{AINT} CC	-	-	30	pF	
Switched capacitance of an analog input	C_{AINS} CC	2	4	7	pF	
Resistance of the analog input path	R_{AIN} CC	-	-	4.5	kOhm	
Switched capacitance of a reference input	C_{AREFS} CC	-	-	30	pF	
RMS Noise ⁷⁾	EN_{RMS} CC	-	-	1.7 ⁶⁾⁸⁾	LSB	
Positive reference V_{AREFX} pin leakage	I_{OZ2} CC	-6	-	6	μA	$V_{AREFX} = V_{AREF1}$; $V_{AREF} > V_{DDM}V$; $T_J > 150^\circ\text{C}$
		-3.5	-	3.5	μA	$V_{AREFX} = V_{AREF1}$; $V_{AREF} > V_{DDM}V$; $T_J \leq 150^\circ\text{C}$
		-3	-	3	μA	$V_{AREFX} = V_{AREF1}$; $V_{AREF} \leq V_{DDM}V$; $T_J > 150^\circ\text{C}$
		-2	-	2	μA	$V_{AREFX} = V_{AREF1}$; $V_{AREF} \leq V_{DDM}V$; $T_J \leq 150^\circ\text{C}$
Negative reference V_{AGNDx} pin leakage	I_{OZ3} CC	-12	-	12	μA	$V_{AGNDx} = V_{AGND1}$; $V_{AGND} < V_{SSM}$; $T_J > 150^\circ\text{C}$
		-6.5	-	6.5	μA	$V_{AGNDx} = V_{AGND1}$; $V_{AGND} < V_{SSM}$; $T_J \leq 150^\circ\text{C}$
		-3	-	3	μA	$V_{AGNDx} = V_{AGND1}$; $V_{AGND} \geq V_{SSM}$; $T_J > 150^\circ\text{C}$
		-2	-	2	μA	$V_{AGNDx} = V_{AGND1}$; $V_{AGND} \geq V_{SSM}$; $T_J \leq 150^\circ\text{C}$
Resistance of the reference input path	R_{AREF} CC	-	-	3	kOhm	
CSD resistance ⁹⁾	R_{CSD} CC	-	-	28	kOhm	

Table 3-28 VADC_33V (cont'd)

Parameter	Symbol	Values			Unit	Note / Test Condition
		Min.	Typ.	Max.		
Resistance of the multiplexer diagnostics pull-down device	R_{MDD} CC	$25 + 3 \cdot V_{IN}$	-	$40 + 12 \cdot V_{IN}$	kOhm	$0 \text{ V} \leq V_{IN} \leq 1.667 \text{ V}$
		$0 + 18 \cdot V_{IN}$	-	$0 + 18 \cdot V_{IN}$	kOhm	$1.667 \text{ V} \leq V_{IN} \leq V_{DDM}$
Resistance of the multiplexer diagnostics pull-up device	R_{MDU} CC	$60 - 12 \cdot V_{IN}$	-	$120 - 30 \cdot V_{IN}$	kOhm	$0 \text{ V} \leq V_{IN} \leq 1.667 \text{ V}$
		$55 - 9 \cdot V_{IN}$	-	$95 - 15 \cdot V_{IN}$	kOhm	$1.667 \text{ V} \leq V_{IN} \leq V_{DDM}$
Resistance of the pull-down test device ¹⁰⁾	R_{PDD} CC	-	-	0.9	kOhm	
CSD voltage accuracy ^{11) 12)}	$dVCSD$ CC	-	-	10	%	
Wakeup time	t_{WU} CC	-	-	12	μs	

- 1) If the reference voltage is reduced by the factor k ($k < 1$), TUE, DNL, INL, Gain, and Offset errors increase also by the factor $1/k$. V_{AREF} must be decoupled with an external capacitor.
- 2) For $QCONV = X$ pC and a conversion time of $1 \mu\text{s}$ a rms value of $X \mu\text{A}$ results for I_{AREFX} .
- 3) For the details of the mapping for a VADC group to pin V_{AREFX} please see the User's Manual.
- 4) The broken wire detection delay against V_{AGND} is measured in numbers of consecutive precharge cycles at a conversion rate higher than 1 conversion per 500 ms.
- 5) The broken wire detection delay against V_{AREF} is measured in numbers of consecutive precharge cycles at a conversion rate higher than 1 conversion per 10 ms. This function is influenced by leakage current, in particular at high temperature.
- 6) Resulting worst case combined error is arithmetic combination of TUE and EN_{RMS} .
- 7) This parameter is valid for soldered devices and requires careful analog board design.
- 8) Value is defined for one sigma Gauss distribution.
- 9) In order to avoid an additional error due to incomplete sampling, the sampling time shall be set greater than $5 \cdot R_{CSD} \cdot C_{AINS}$.
- 10) The pull-down resistor R_{PDD} is connected between the input pad and the analog multiplexer. The input pad itself adds another 200-Ohm series resistance, when measuring through the pin.
- 11) CSD: Converter Self Diagnostics, for details please consult the User's Manual.
- 12) Note, that in case CSD voltage is chosen to nom. 1/3 or 2/3 of V_{AREF} voltage, the reference voltage is loaded with a current of max. $V_{AREF} / 45 \text{ kOhm}$.

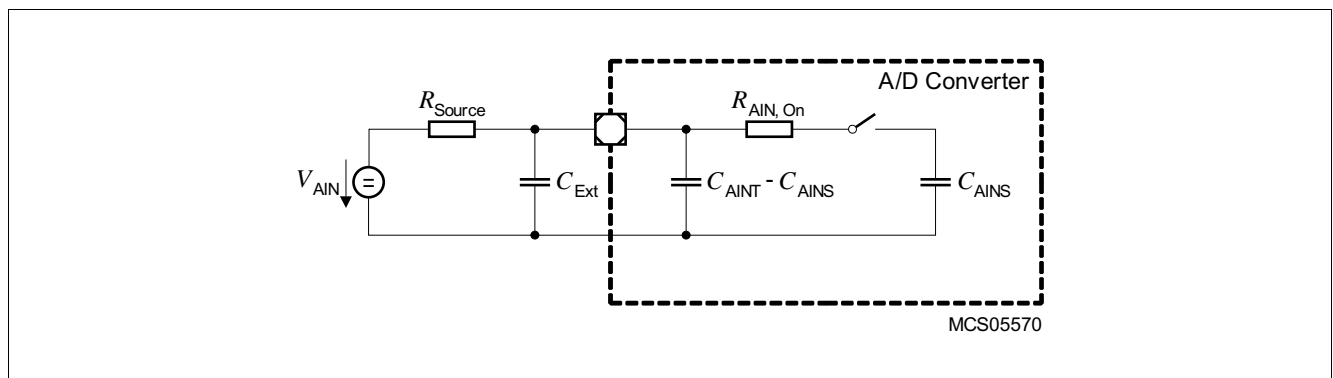

Figure 3-2 Equivalent Circuitry for Analog Inputs

3.10 DSADC Parameters

The following DSADC parameter are valid for $V_{DDM} = 4.5 \text{ V}$ to 5.5 V .

Table 3-29 DSADC

Parameter	Symbol	Values			Unit	Note / Test Condition
		Min.	Typ.	Max.		
Analog input voltage range ¹⁾	V_{DSIN} SR	0	-	5	V	single ended
		0	-	10	V	differential; $V_{DSxP} - V_{DSxN}$
Reference load current	I_{REF} SR	-	4.5 ²⁾	7.8 ²⁾	μA	per twin-modulator (1 or 2 channels)
Modulator clock frequency ³⁾	f_{MOD} SR	10	-	20	MHz	
Gain error	ED_{GAIN} CC	-1	-	1 ⁴⁾	%	Calibrated once
		-3.5 ⁵⁾	-	3.5 ⁵⁾	%	Uncalibrated
		-0.2	-	0.2 ⁶⁾	%	calibrated; GAIN = 1; MODCFG.INCFGx=01
DC offset error	ED_{OFF} CC	-5	-	5 ⁶⁾	mV	calibrated
		-50	-	50	mV	calibrated once
		-100 ⁵⁾⁷⁾	0 ⁵⁾⁷⁾	100 ⁵⁾	mV	gain = 1; uncalibrated
Common Mode Rejection Ratio	ED_{CM} CC	200	500	-		
Input impedance ⁸⁾	R_{DAIN} CC	100	130	170	kOhm	Exact value ($\pm 1\%$) available in UCB
Signal-Noise Ratio ^{9) 10) 11) 12)}	SNR CC	80	-	-	dB	$f_{PB} = 30 \text{ kHz}$; $V_{DDM} = \pm 5\%$; $f_{MOD} = 20 \text{ MHz}$; GAIN = 1
		78	-	-	dB	$f_{PB} = 50 \text{ kHz}$; $V_{DDM} = \pm 5\%$; $f_{MOD} = 20 \text{ MHz}$; GAIN = 1
		70	-	-	dB	$f_{PB} = 100 \text{ kHz}$; $V_{DDM} = \pm 10\%$; $f_{MOD} = 20 \text{ MHz}$; GAIN = 1
		74	-	-	dB	$f_{PB} = 100 \text{ kHz}$; $V_{DDM} = \pm 5\%$; $f_{MOD} = 20 \text{ MHz}$; GAIN = 1
		76	-	-	dB	$f_{PB} = 30 \text{ kHz}$; $V_{DDM} = \pm 10\%$; $f_{MOD} = 20 \text{ MHz}$; GAIN = 1
		74	-	-	dB	$f_{PB} = 50 \text{ kHz}$; $V_{DDM} = \pm 10\%$; $f_{MOD} = 20 \text{ MHz}$; GAIN = 1
Pass band	f_{PB} CC	10 ¹³⁾	-	100	kHz	Output data rate $f_D = f_{PB} * 3$
Pass band ripple ¹⁰⁾	df_{PB} CC	-1	-	1	%	
Output sampling rate	f_D CC	30	-	330	kHz	

Electrical Specification DSADC Parameters

Table 3-29 DSADC (cont'd)

Parameter	Symbol	Values			Unit	Note / Test Condition
		Min.	Typ.	Max.		
DC compensation factor	DCF CC	-3	-	-	dB	$10^{-5} f_D$
Positive reference V_{AREF1} pin leakage	I_{OZ5} CC	-2	-	2	μA	$V_{VAREF_x} = V_{VAREF1}$; $V_{VAREF} \leq V_{DDM}$; $T_J \leq 150$ °C
		-3	-	3	μA	$V_{VAREF_x} = V_{VAREF1}$; $V_{VAREF} \leq V_{DDM}$; $T_J > 150$ °C
		-4	-	4	μA	$V_{VAREF_x} = V_{VAREF1}$; $V_{VAREF} > V_{DDM}$; $T_J \leq 150$ °C
		-7	-	7	μA	$V_{VAREF_x} = V_{VAREF1}$; $V_{VAREF} > V_{DDM}$; $T_J > 150$ °C
Negative reference V_{AGND1} pin leakage	I_{OZ6} CC	-2.5	-	2.5	μA	$V_{AGND_x} = V_{AGND1}$; $V_{AGND} > V_{SSM}$; $T_J \leq 150$ °C
		-3	-	3	μA	$V_{AGND_x} = V_{AGND1}$; $V_{AGND} > V_{SSM}$; $T_J > 150$ °C
		-7	-	7	μA	$V_{AGND_x} = V_{AGND1}$; $V_{AGND} < V_{SSM}$; $T_J \leq 150$ °C
		-13	-	13	μA	$V_{AGND_x} = V_{AGND1}$; $V_{AGND} < V_{SSM}$; $T_J > 150$ °C
Stop band attenuation ¹⁰⁾	SBA CC	40	-	-	dB	$0.5 \dots 1 f_D$
		45	-	-	dB	$1 \dots 1.5 f_D$
		50	-	-	dB	$1.5 \dots 2 f_D$
		55	-	-	dB	$2 \dots 2.5 f_D$
		60	-	-	dB	$2.5 \dots OSR/2 f_D$
Reference ground voltage	V_{AGND} SR	$V_{SSM} - 0.05$	-	$V_{SSM} + 0.05$	V	
Positive reference voltage	V_{AREF} SR	$V_{DDMnom} * 0.9$	-	$V_{DDM} + 0.05$	V	
Common mode voltage accuracy	dV_{CM} CC	-100	-	100	mV	from selected voltage
Common mode hold voltage deviation ¹⁴⁾	dV_{CMH} CC	-200	-	200	mV	From common mode voltage
Analog filter settling time	t_{AFSET} CC	-	2	4	μs	If enabled
Modulator recovery time	t_{MREC} CC	-	3.5	5.5	μs	After leaving overdrive state

Electrical Specification DSADC Parameters

Table 3-29 DSADC (cont'd)

Parameter	Symbol	Values			Unit	Note / Test Condition
		Min.	Typ.	Max.		
Modulator settling time ¹⁵⁾	t_{MSET} CC	-	1	-	μ s	After switching on, voltage regulator already running
Spurious Free Dynamic Range ⁹⁾¹⁶⁾	SFDR CC	60	-	-	dB	$V_{CM} = 2.2$ V, DC coupled; $V_{DDM} = \pm 10\%$

- 1) The maximum input range for symmetrical signals (e.g. AC-coupled inputs) depends on the selected internal/external common mode voltage. In this case the Amplitude is limited to $V_{CM} * 2$.
- 2) When measuring at pin VAREF1, leakage/operating currents of the VADC must be added to I_{REF} .
- 3) All modulators must run on the same frequency.
- 4) The calibration sequence must be executed once after an Application Reset
- 5) The total DC error for the uncalibrated case can be calculated by the geometric addition of ED_{GAIN} and ED_{OFF}
- 6) Recalibration needed in case of a temperature change $> 20^{\circ}C$
- 7) Systematic offset shift
- 8) The variation of the impedance between different channels is $< 1.5\%$.
- 9) Derating factors:
 - 2 dB in standard-performance mode.
 - 3 dB for $CMV = 10_B$, i.e. $V_{CM} = (V_{AREF} \pm 2\%) / 2.0$.
- 10) CIC3, FIR0, FIR1 filters enabled.
- 11) Single-ended mode reduces the SNR by 6 dB if the unused input is grounded, by 3 dB if the unused input connects to V_{CM} (GAIN = 2).
- 12) The defined limits are only valid if the following condition is not applicable: $T_J > 150^{\circ}C$ and $V_{VAREF} > V_{DDM}$.
- 13) 10 kHz only reachable with 10 MHz modulator clock frequency.
- 14) Voltage V_{CM} is proportional to V_{AREF} , voltage V_{CMH} is proportional to V_{DDM} .
- 15) The modulator needs to settle after being switched on and after leaving the overdrive state.
- 16) $SFDR = 20 * \log(INL / 2^N)$; N = amount of bits

The following DSADC parameter are valid for $V_{DDM} = 2.97$ V to 3.63 V.

Table 3-30 DSADC_33V

Parameter	Symbol	Values			Unit	Note / Test Condition
		Min.	Typ.	Max.		
Analog input voltage range ¹⁾	V_{DSIN} SR	0	-	3.3	V	single ended
		0	-	6.6	V	differential; $V_{DSxP} - V_{DSxN}$
Reference load current	I_{REF} SR	-	4.5 ²⁾	6.9 ²⁾	μ A	per twin-modulator (1 or 2 channels)
Modulator clock frequency ³⁾	f_{MOD} SR	10	-	20	MHz	
Gain error	ED_{GAIN} CC	-1.5	-	1.5 ⁴⁾	%	Calibrated once
		-10 ⁵⁾	-	10 ⁵⁾	%	Uncalibrated
		-0.3	-	0.3 ⁶⁾	%	calibrated; GAIN = 1; MODCFG.INCFGx=01
DC offset error	ED_{OFF} CC	-5	-	5 ⁶⁾	mV	calibrated
		-50	-	50	mV	calibrated once
		-100 ⁵⁾	0 ⁵⁾	100 ⁵⁾	mV	gain = 1; uncalibrated

Electrical Specification DSADC Parameters

Table 3-30 DSADC_33V (cont'd)

Parameter	Symbol	Values			Unit	Note / Test Condition
		Min.	Typ.	Max.		
Common Mode Rejection Ratio	ED_{CM} CC	200	500	-		
Input impedance ⁷⁾	R_{DAIN} CC	100	130	170	kOhm	Exact value ($\pm 1\%$) available in UCB
Signal-Noise Ratio ^{8) 9) 10) 11)}	SNR CC	45	63	-	dB	$f_{PB} = 100\text{kHz}$; $V_{DDM} = \pm 10\%$; $f_{MOD} = 20\text{ MHz}$; GAIN = 1
		60	69	-	dB	$f_{PB} = 100\text{kHz}$; $V_{DDM} = \pm 5\%$; $f_{MOD} = 20\text{ MHz}$; GAIN = 1
		60	68	-	dB	$f_{PB} = 30\text{kHz}$; $V_{DDM} = \pm 10\%$; $f_{MOD} = 20\text{ MHz}$; GAIN = 1
		69	74	-	dB	$f_{PB} = 30\text{kHz}$; $V_{DDM} = \pm 5\%$; $f_{MOD} = 20\text{ MHz}$; GAIN = 1
		55	66	-	dB	$f_{PB} = 50\text{kHz}$; $V_{DDM} = \pm 10\%$; $f_{MOD} = 20\text{ MHz}$; GAIN = 1
		65	72	-	dB	$f_{PB} = 50\text{kHz}$; $V_{DDM} = \pm 5\%$; $f_{MOD} = 20\text{ MHz}$; GAIN = 1
Pass band	f_{PB} CC	10 ¹²⁾	-	100	kHz	Output data rate $f_D = f_{PB} * 3$
Pass band ripple ⁹⁾	df_{PB} CC	-1	-	1	%	
Output sampling rate	f_D CC	30	-	330	kHz	
DC compensation factor	DCF CC	-3	-	-	dB	$10^{-5} f_D$
Positive reference V_{AREF1} pin leakage	I_{OZ5} CC	-6	-	6	μA	$V_{AREFX} = V_{AREF1}$; $V_{AREF} > V_{DDM}$; $T_J > 150\text{ }^\circ\text{C}$
		-3.5	-	3.5	μA	$V_{AREFX} = V_{AREF1}$; $V_{AREF} > V_{DDM}$; $T_J \leq 150\text{ }^\circ\text{C}$
		-3	-	3	μA	$V_{AREFX} = V_{AREF1}$; $V_{AREF} \leq V_{DDM}$; $T_J > 150\text{ }^\circ\text{C}$
		-2	-	2	μA	$V_{AREFX} = V_{AREF1}$; $V_{AREF} \leq V_{DDM}$; $T_J \leq 150\text{ }^\circ\text{C}$

Electrical Specification DSADC Parameters

Table 3-30 DSADC_33V (cont'd)

Parameter	Symbol	Values			Unit	Note / Test Condition
		Min.	Typ.	Max.		
Negative reference V_{AGND1} pin leakage	I_{OZ6} CC	-2	-	2	μA	$V_{AGNDx} = V_{AGND1}$; $V_{AGND} \geq V_{SSM}$; $T_J \leq 150$ °C
		-3	-	3	μA	$V_{AGNDx} = V_{AGND1}$; $V_{AGND} \geq V_{SSM}$; $T_J > 150$ °C
		-6.5	-	6.5	μA	$V_{AGNDx} = V_{AGND1}$; $V_{AGND} < V_{SSM}$; $T_J \leq 150$ °C
		-12	-	12	μA	$V_{AGNDx} = V_{AGND1}$; $V_{AGND} < V_{SSM}$; $T_J > 150$ °C
Stop band attenuation ⁹⁾	SBA CC	40	-	-	dB	$0.5 \dots 1 f_D$
		45	-	-	dB	$1 \dots 1.5 f_D$
		50	-	-	dB	$1.5 \dots 2 f_D$
		55	-	-	dB	$2 \dots 2.5 f_D$
		60	-	-	dB	$2.5 \dots OSR/2 f_D$
Reference ground voltage	V_{AGND} SR	$V_{SSM} - 0.05$	-	$V_{SSM} + 0.05$	V	
Positive reference voltage	V_{AREF} SR	$V_{DDMnom} * 0.9$	-	$V_{DDM} + 0.05$	V	
Common mode voltage accuracy	dV_{CM} CC	-100	-	100	mV	from selected voltage
Common mode hold voltage deviation ¹³⁾	dV_{CMH} CC	-200	-	200	mV	From common mode voltage
Analog filter settling time	t_{AFSET} CC	-	2	4	μs	If enabled
Modulator recovery time	t_{MREC} CC	-	3.5	-	μs	After leaving overdrive state
Modulator settling time ¹⁴⁾	t_{MSET} CC	-	1	-	μs	After switching on, voltage regulator already running
Spurious Free Dynamic Range ⁸⁾¹⁵⁾	SFDR CC	52	-	-	dB	$V_{CM} = 2.2$ V, DC coupled; $V_{DDM} = \pm 10\%$
		60	-	-	dB	$V_{CM} = 2.2$ V, DC coupled; $V_{DDM} = \pm 5\%$

- 1) The maximum input range for symmetrical signals (e.g. AC-coupled inputs) depends on the selected internal/external common mode voltage. In this case the Amplitude is limited to $V_{CM} * 2$.
- 2) When measuring at pin VAREF1, leakage/operating currents of the VADC must be added to I_{REF} .
- 3) All modulators must run on the same frequency.
- 4) The calibration sequence must be executed once after an Application Reset
- 5) The total DC error for the uncalibrated case can be calculated by the geometric addition of ED_{GAIN} and ED_{OFF}
- 6) Recalibration needed in case of a temperature change $> 20^\circ\text{C}$.
- 7) The variation of the impedance between different channels is $< 1.5\%$.

- 8) Derating factors:
 - 2 dB in standard-performance mode.
 - 3 dB for $CMV = 10_B$, i.e. $V_{CM} = (V_{AREF} \pm 2\%) / 2.0$.
- 9) CIC3, FIR0, FIR1 filters enabled.
- 10) Single-ended mode reduces the SNR by 6 dB if the unused input is grounded, by 3 dB if the unused input connects to V_{CM} (GAIN = 2).
- 11) The defined limits are only valid if the following condition is not applicable: $T_J > 150^\circ\text{C}$ and $V_{VAREF} > V_{DDM}$.
- 12) 10 kHz bandwidth only with 10MHz modulator clock frequency reachable
- 13) Voltage V_{CM} is proportional to V_{AREF} , voltage V_{CMH} is proportional to V_{DDM} .
- 14) The modulator needs to settle after being switched on and after leaving the overdrive state.
- 15) $SFDR = 20 * \log(INL / 2^N)$; N = amount of bits

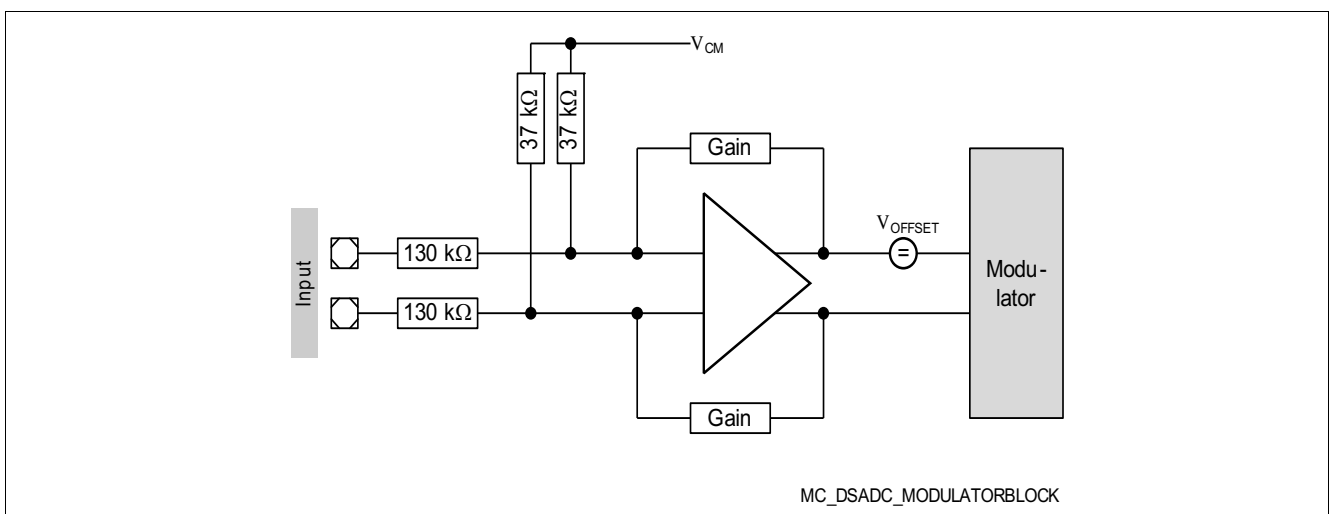

Figure 3-3 DSADC Analog Inputs

3.11 MHz Oscillator

OSC_XTAL is used as accurate and exact clock source. OSC_XTAL supports 8 MHz to 40 MHz crystals external outside of the device. Support of ceramic resonators is also provided.

Table 3-31 OSC_XTAL

Parameter	Symbol	Values			Unit	Note / Test Condition
		Min.	Typ.	Max.		
Input current at XTAL1	I_{IX1} CC	-25	-	25	μA	$V_{IN} > 0\text{V}; V_{IN} < V_{DDP3}\text{V}$
Oscillator frequency	f_{OSC} SR	4	-	40	MHz	Direct Input Mode selected
		8	-	40	MHz	External Crystal Mode selected
Oscillator start-up time ¹⁾	t_{OSCS} CC	-	-	5 ²⁾	ms	
Input high voltage at XTAL1	V_{IHBX} SR	0.8	-	$V_{DDP3} + 0.5$	V	If shaper is bypassed
Input low voltage at XTAL1	V_{ILBX} SR	-0.5	-	0.4	V	If shaper is bypassed
Input voltage at XTAL1	V_{IX} SR	-0.5	-	$V_{DDP3} + 0.5$	V	If shaper is not bypassed
Input amplitude (peak to peak) at XTAL1	V_{PPX} SR	0.3 * V_{DDP3}	-	$V_{DDP3} + 1.0$	V	If shaper is not bypassed; $f_{OSC} > 25\text{MHz}$
		0.4 * V_{DDP3}	-	$V_{DDP3} + 1.0$	V	If shaper is not bypassed; $f_{OSC} \leq 25\text{MHz}$
Internal load capacitor	C_{L0} CC	2	2.35	2.7	pF	
Internal load capacitor	C_{L1} CC	2	2.35	2.7	pF	
Internal load capacitor	C_{L2} CC	3	3.5	4	pF	
Internal load capacitor	C_{L3} CC	5.1	5.9	6.6	pF	

1) t_{OSCS} is defined from the moment when $V_{DDP3} = 3.13\text{V}$ until the oscillations reach an amplitude at XTAL1 of $0.3 * V_{DDP3}$. The external oscillator circuitry must be optimized by the customer and checked for negative resistance as recommended and specified by crystal suppliers.

2) This value depends on the frequency of the used external crystal. For faster crystal frequencies this value decrease.

Note: It is strongly recommended to measure the oscillation allowance (negative resistance) in the final target system (layout) to determine the optimal parameters for the oscillator operation. Please refer to the limits specified by the crystal or ceramic resonator supplier.

3.12 Back-up Clock

The back-up clock provides an alternative clock source.

Table 3-32 Back-up Clock

Parameter	Symbol	Values			Unit	Note / Test Condition
		Min.	Typ.	Max.		
Back-up clock before trimming	f_{BACKUT} CC	75	100	125	MHz	$V_{\text{EXT}} \geq 2.97\text{V}$
Slow speed Back-up clock	f_{BACKSS} CC	75	100	125	kHz	$V_{\text{EXT}} \geq 2.97\text{V}$
Back-up clock after trimming	f_{BACKT} CC	97.5	100	102.5	MHz	$V_{\text{EXT}} \geq 2.97\text{V}$

3.13 Temperature Sensor

Table 3-33 DTS

Parameter	Symbol	Values			Unit	Note / Test Condition
		Min.	Typ.	Max.		
Measurement time	t_M CC	-	-	100	μs	
Calibration reference accuracy	T_{CALACC} CC	-1	-	1	°C	calibration points @ $T_J = -40^\circ\text{C}$ and $T_J = 127^\circ\text{C}$
Non-linearity accuracy over temperature range	T_{NL} CC	-2	-	2	°C	
Temperature sensor range	T_{SR} SR	-40	-	170	°C	
Start-up time after resets inactive	t_{TSST} SR	-	-	20	μs	

The following formula calculates the temperature measured by the DTS in [°C] from the RESULT bit field of the DTSSTAT register.

(3.1)

$$T_J = \frac{DTSSTATRESULT - (607)}{2,13}$$

3.14 Power Supply Current

The total power supply current defined below consists of leakage and switching component.

Application relevant values are typically lower than those given in the following table and depend on the customer's system operating conditions (e.g. thermal connection or used application configurations).

The operating conditions for the parameters in the following table are:

The real (realistic) power pattern defines the following conditions:

- $T_J = 150\text{ °C}$
- $f_{\text{CPU0}} = 80\text{ MHz}$
- $f_{\text{SRI}} = f_{\text{MAX}} = f_{\text{CPU1}} = 160\text{ MHz}$
- $f_{\text{SPB}} = f_{\text{STM}} = f_{\text{GTM}} = f_{\text{BAUD1}} = f_{\text{BAUD2}} = f_{\text{ASCLIN}} = 40\text{ MHz}$
- $V_{\text{DD}} = 1.326\text{ V}$
- $V_{\text{DDP3}} = 3.366\text{ V}$
- $V_{\text{EXT / FLEX}} = V_{\text{DDM}} = 5.1\text{ V}$
- all cores are active including one lockstep core
- the following peripherals are inactive: HSM, HSCT, Ethernet, PSI5, I2C, FCE, MTU, and 50% of the DSADC channels

The max power pattern defines the following conditions:

- $T_J = 150\text{ °C}$
- $f_{\text{SRI}} = f_{\text{MAX}} = f_{\text{CPU0}} = 200\text{ MHz}$
- $f_{\text{SPB}} = f_{\text{STM}} = f_{\text{GTM}} = f_{\text{BAUD1}} = f_{\text{BAUD2}} = f_{\text{ASCLIN}} = 100\text{ MHz}$
- $V_{\text{DD}} = 1.43\text{ V}$
- $V_{\text{DDP3}} = 3.63\text{ V}$
- $V_{\text{EXT / FLEX}} = V_{\text{DDM}} = 5.5\text{ V}$
- all cores and lockstep cores are active
- all peripherals are active

Table 3-34 Power Supply

Parameter	Symbol	Values			Unit	Note / Test Condition
		Min.	Typ.	Max.		
Σ Sum of I_{DD} 1.3 V core and peripheral supply currents	$I_{\text{DD CC}}$	-	-	380 ¹⁾	mA	valid for Feature Package D and DC; max power pattern
		-	-	198 ¹⁾	mA	valid for Feature Package D and DC; real power pattern
		-	-	432	mA	valid for Feature Package DA; max power pattern
		-	-	250	mA	valid for Feature Package DA; real power pattern

Electrical Specification Power Supply Current

Table 3-34 Power Supply (cont'd)

Parameter	Symbol	Values			Unit	Note / Test Condition
		Min.	Typ.	Max.		
I_{DD} core current during active power-on reset (PORST held low)	$I_{DDPORST}$ CC	-	-	60	mA	valid for Feature Package D and DC; $T_J=125^\circ\text{C}$
		-	-	112	mA	valid for Feature Package D and DC; $T_J=150^\circ\text{C}$
		-	-	103	mA	valid for Feature Package DA; $T_J=125^\circ\text{C}$
		-	-	160	mA	valid for Feature Package D and DC; $T_J=165^\circ\text{C}$
		-	-	154	mA	valid for Feature Package DA; $T_J=150^\circ\text{C}$
		-	-	216	mA	valid for Feature Package DA; $T_J=165^\circ\text{C}$
I_{DD} core current of CPU1 main core with CPU1 lockstep core inactive	I_{DDC10} CC	-	-	38	mA	real power pattern
I_{DD} core current of CPU1 main core with lockstep core active	I_{DDC11} CC	-	-	$I_{DDC10} + 32$	mA	real power pattern
I_{DD} core current added by FFT	I_{DDFFT} CC	-	-	40	mA	FFT running at 200MHz
Σ Sum of 3.3 V supply currents without pad activity	$I_{DDx3RAIL}$ CC	-	-	46 ²⁾	mA	real power pattern
I_{DDFL3} Flash memory current	I_{DDFL3} CC	-	-	33 ³⁾	mA	flash read current
		-	-	33 ⁴⁾	mA	flash read current while programming Dflash
I_{DDP3} supply current without pad activity	I_{DDP3} CC	-	-	13 ³⁾	mA	real power pattern; incl. OSC & flash read current
		-	-	27 ⁵⁾	mA	incl. OSC current and flash 3.3V programming current when using external 5V supply
		-	-	31 ⁴⁾	mA	incl. OSC current and flash programming current when using 3.3V supply only

Electrical Specification Power Supply Current

Table 3-34 Power Supply (cont'd)

Parameter	Symbol	Values			Unit	Note / Test Condition
		Min.	Typ.	Max.		
I_{DDP3} supply current for LVDSH pads in LVDS mode	$I_{DDP3LVDSH}$ CC	-	-	16	mA	
Σ Sum of external and ADC supply currents (incl. $I_{EXTFLEX} + I_{DDM} + I_{EXTLVDSM}$)	$I_{EXTRAIL}$ CC	-	-	31	mA	real power pattern
Sum of I_{EXT} and I_{FLEX} supply current without pad activity	$I_{EXT/FLEX}$ CC	-	-	11	mA	real power pattern; PORST output inactive.
I_{EXT} supply current for LVDSM pads in LVDS mode	$I_{EXTLVDSM}$ CC	-	-	6 ⁶⁾	mA	real power pattern
I_{DDM} supply current	I_{DDM} CC	-	-	14	mA	real power pattern; sum of currents of DSADC and VADC modules
		-	-	12	mA	current for DSADC module only; 50% DSADC channels active.
		-	-	32 ⁷⁾	mA	max power pattern; All DSADC channels active 100% time.
		-	-	2	mA	real pattern; current for VADC only
		-	-	7 ⁸⁾	mA	max power pattern; All VADC converters are active 100% time
Σ Sum of all currents (incl. $I_{EXTRAIL} + I_{DDx3RAIL} + I_{DD}$)	I_{DDTOT} CC	-	-	275	mA	valid for Feature Package D and DC; real power pattern
		-	-	327	mA	valid for Feature Package DA; real power pattern
Σ Sum of all currents with DC-DC EVR13 regulator active ⁹⁾	$I_{DDTOTDC3}$ CC	-	-	180	mA	real power pattern; $V_{EXT} = 3.3V$
Σ Sum of all currents with DC-DC EVR13 regulator active ⁹⁾	$I_{DDTOTDC5}$ CC	-	-	150	mA	real power pattern; $V_{EXT} = 5V$
Σ Sum of all currents (STANDBY mode)	I_{EVRSB} CC	-	-	150 ¹⁰⁾	μA	Standby RAM is active. Power to remaining domains switched off. $T_J = 25^\circ C$; $V_{EVRSB} = 5V$

Electrical Specification Power Supply Current

Table 3-34 Power Supply (cont'd)

Parameter	Symbol	Values			Unit	Note / Test Condition
		Min.	Typ.	Max.		
Σ Sum of all currents (SLEEP mode)	$I_{\text{SLEEP CC}}$	-	-	15	mA	All CPUs in idle, All peripherals in sleep, $f_{\text{SRI/SPB}} = 1 \text{ MHz}$ via LPDIV divider; $T_J = 25^\circ\text{C}$; valid for Feature Package D and DC
		-	-	19	mA	All CPUs in idle, All peripherals in sleep, $f_{\text{SRI/SPB}} = 1 \text{ MHz}$ via LPDIV divider; $T_J = 25^\circ\text{C}$; valid for Feature Package DA
Maximum power dissipation	$PD \text{ CC}$	-	-	1090	mW	valid for Feature Package D and DC; max power pattern
		-	-	614	mW	valid for Feature Package D and DC; real power pattern
		-	-	1145	mW	valid for Feature Package DA; max power pattern
		-	-	669	mW	valid for Feature Package DA; real power pattern
SCR 8-bit Standby Controller in STANDBY Mode	$I_{\text{SCR SB CC}}$	-	25	-	μA	$f_{\text{SYS_SCR}} = 100\text{KHz}$; $T_J = 25^\circ\text{C}$
		-	-	4	mA	$f_{\text{SYS_SCR}} = 20\text{MHz}$; $T_J = 25^\circ\text{C}$
SCR 8-bit Standby Controller CPU in IDLE mode	$I_{\text{SCR IDLE CC}}$	-	-	1	mA	

- 1) The real pattern usecase is limited to 160 MHz in TC26x to limit the I_{DD} current to less than 200 mA to ensure that internal pass devices of EVR13 LDO can deliver the required I_{DD} current. The max pattern I_{DD} current can only be met with EVR13 LDO using external pass devices or EVR13 SMPS mode.
- 2) In case EVR33 is not used, Injection current into 3.3V VDDP3 supply rail with active sink on 5V VEXT rail should be limited to 500 mA if during power sequencing 3.3V is supplied before 5V by external regulator.
- 3) Realistic Pflash read pattern with 70% Pflash bandwidth utilization and a code mix of 50% 0s and 50% 1s. Dynamic Flash Idle via FCON.IDLE is activated bringing a benefit of 8 mA. A common decoupling capacitor of atleast 100nF for ($V_{\text{DDFL3}} + V_{\text{DDP3}}$) is used. Dflash read current is also included. Flash read current is predominantly drawn from V_{DDFL3} pin and a minor part drawn from the neighbouring V_{DDP3} pin.
- 4) Continuous Dflash programming in burst mode with 3.3 V supply and realistic Pflash read access in parallel. Dynamic Flash Idle via FCON.IDLE is activated bringing a benefit of 8 mA. Erase currents of the corresponding flash modules are less than the respective programming currents at V_{DDP3} pin. Programming and erasing flash may generate transient current spikes of up to x mA for maximum x us which is handled by the decoupling and buffer capacitors. This parameter is relevant for external power supply dimensioning and not for thermal considerations.
- 5) In addition to the current specified, upto 4 mA is additionally drawn at V_{EXT} supply in burst programming mode with 5V external supply. Erase currents of the corresponding flash modules are less than the respective programming currents at V_{DDP3} supply. This parameter is relevant for external power supply dimensioning and not for thermal considerations.

- 6) The current consumption is for 1 pair of LVDSM differential pads (4 pins).
- 7) The current consumption is for 6 DS channels with standard performance (MCFG=11b). A single DS channel instance consumes 6-8 mA.
- 8) A single converter instance of VADC unit consumes 2 mA.
- 9) The total current drawn from external regulator is estimated with 72% EVR13 SMPS regulator Efficiency. $I_{DDTOTDCX}$ is calculated from I_{DDTOT} using the scaled core current $[(I_{DD} \times V_{DD}) / (V_{in} \times \text{Efficiency})]$ and constitutes all other rail currents and I_{DDM} .
- 10) Current at V_{EVRSB} supply pin during normal RUN mode is less than 5 mA at $T_J = 150^\circ\text{C}$. The transition between RUN mode to STANDBY mode has a duration of less than 100us during which the current is higher but is less than 8 mA at $T_J = 150^\circ\text{C}$. Once STANDBY mode is entered with only Standby RAM active the current is less than 5mA at $T_J = 150^\circ\text{C}$. It is recommended to have atleast 100 nF decoupling capacitor at this pin. The standby current indicated is solely drawn from VEVR SB pin.

3.14.1 Calculating the 1.3 V Current Consumption

The current consumption of the 1.3 V rail compose out of two parts:

- Static current consumption
- Dynamic current consumption

The static current consumption is related to the device temperature T_J and the dynamic current consumption depends of the configured clocking frequencies and the software application executed. These two parts needs to be added in order to get the rail current consumption.

Valid for Feature Package D and DC products:

$$I_0 = 0,741 \left[\frac{\text{mA}}{\text{C}} \right] \times e^{0,0255 \times T_J[\text{C}]} \quad (3.2)$$

$$I_0 = 2,86 \left[\frac{\text{mA}}{\text{C}} \right] \times e^{0,0244 \times T_J[\text{C}]} \quad (3.3)$$

Valid for Feature Package DA products:

$$I_0 = 0,99 \left[\frac{\text{mA}}{\text{C}} \right] \times e^{0,02483 \times T_J[\text{C}]} \quad (3.4)$$

$$I_0 = 4,8 \left[\frac{\text{mA}}{\text{C}} \right] \times e^{0,02308 \times T_J[\text{C}]} \quad (3.5)$$

Function 2 defines the typical static current consumption and Function 3 defines the maximum static current consumption. Both functions are valid for $V_{DD} = 1.326 \text{ V}$.

3.15 Power-up and Power-down

3.15.1 External Supply Mode

5 V & 1.3 V supplies are externally supplied. 3.3V is generated internally by EVR33.

- External supplies VEXT and VDD may ramp-up or ramp-down independent of each other with regards to start, rise and fall time(s). Voltage Ramp-up from a residual threshold (Eg : up to 1 V) should also lead to a normal startup of the device.
- The rate at which current is drawn from the external regulator (dI_{EXT}/dt or dI_{DD}/dt) is limited in the Start-up phase to a maximum of 50 mA/100 us.
- PORST is active/asserted when either PORST (input) or PORST (output) is active/asserted.
- PORST (input) active means that the reset is held active by external agents by pulling the PORST pin low. It is recommended to keep the PORST (input) asserted until all the external supplies are above their primary reset thresholds.
- PORST (output) active means that μC asserts the reset internally and drives the PORST pin low thus propagating the reset to external devices. The PORST (output) is asserted by the μC when atleast one among the three supply domains (1.3 V, 3.3 V or 5 V) violate their primary under-voltage reset thresholds. The PORST (output) is deasserted by the μC when all supplies are above their primary reset thresholds and the basic supply and clock infrastructure is available.
- The power sequence as shown in [Figure 3-4](#) is enumerated below
 - T1 refers to the point in time when basic supply and clock infrastructure is available as the external supplies ramp up. The supply mode is evaluated based on the HWCFG [0:2] pins and consequently a soft start of EVR33 regulator is initiated.
 - T2 refers to the point in time when all supplies are above their primary reset thresholds. EVR33 regulator has ramped up. PORST (output) is deasserted and HWCFG [0:7] pins are latched on PORST rising edge. Firmware execution is initiated.
 - T3 refers to the point in time when Firmware execution is completed. User code execution starts with a default frequency of 100 MHz.
 - T4 refers to the point in time during the Ramp-down phase when atleast one of the externally provided or generated supplies (1.3 V, 3.3 V or 5 V) drop below their respective primary under-voltage reset thresholds.

Please note that there is no special requirements for \overline{PORST} slew rates.

Electrical Specification Power-up and Power-down

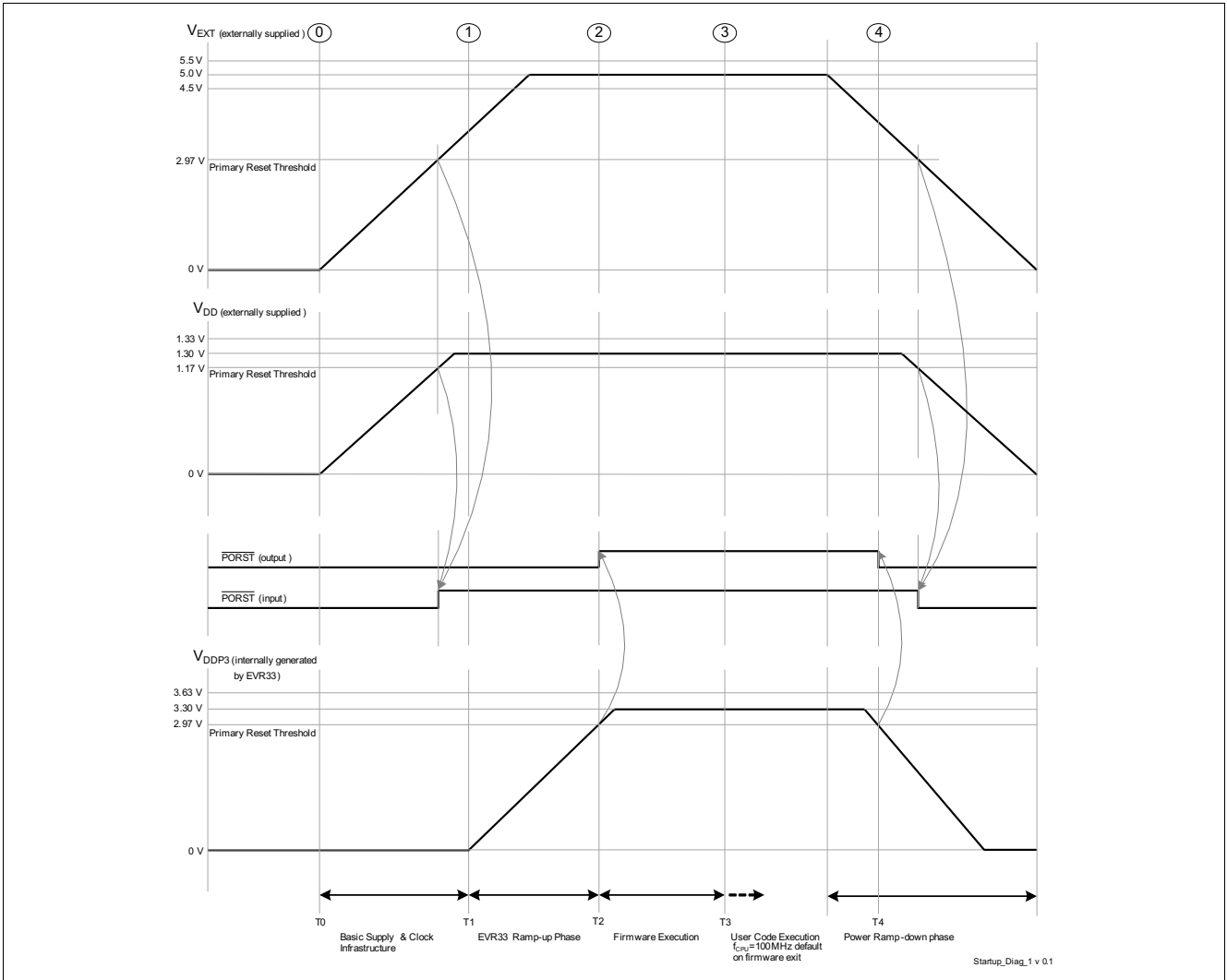

Figure 3-4 External Supply Mode - 5 V and 1.3 V externally supplied

3.15.2 Single Supply Mode

5 V single supply mode. 1.3 V & 3.3 V are generated internally by EVR13 & EVR33.

- The rate at which current is drawn from the external regulator (dI_{EXT}/dt) is limited in the Start-up phase to a maximum of 50 mA/100 μ s.
- PORST is active/asserted when either PORST (input) or PORST (output) is active/asserted.
- PORST (input) active means that the reset is held active by external agents by pulling the PORST pin low. It is recommended to keep the PORST (input) asserted until the external supply is above the respective primary reset threshold.
- PORST (output) active means that μ C asserts the reset internally and drives the PORST pin low thus propagating the reset to external devices. The PORST (output) is asserted by the μ C when at least one among the three supply domains (1.3 V, 3.3 V or 5 V) violate their primary under-voltage reset thresholds. The PORST (output) is deasserted by the μ C when all supplies are above their primary reset thresholds and the basic supply and clock infrastructure is available.
- The power sequence as shown in [Figure 3-5](#) is enumerated below
 - T1 refers to the point in time when basic supply and clock infrastructure is available as the external supply ramps up. The supply mode is evaluated based on the HWCFG [0:2] pins and consequently a soft start of EVR13 and EVR33 regulators are initiated.
 - T2 refers to the point in time when all supplies are above their primary reset thresholds. EVR13 and EVR33 regulators have ramped up. PORST (output) is deasserted and HWCFG [0:7] pins are latched on PORST rising edge. Firmware execution is initiated.
 - T3 refers to the point in time when Firmware execution is completed. User code execution starts with a default frequency of 100 MHz.
 - T4 refers to the point in time during the Ramp-down phase when at least one of the externally provided or generated supplies (1.3 V, 3.3 V or 5 V) drop below their respective primary under-voltage reset thresholds.

Please note that there is no special requirements for $\overline{\text{PORST}}$ slew rates.

Electrical Specification Power-up and Power-down

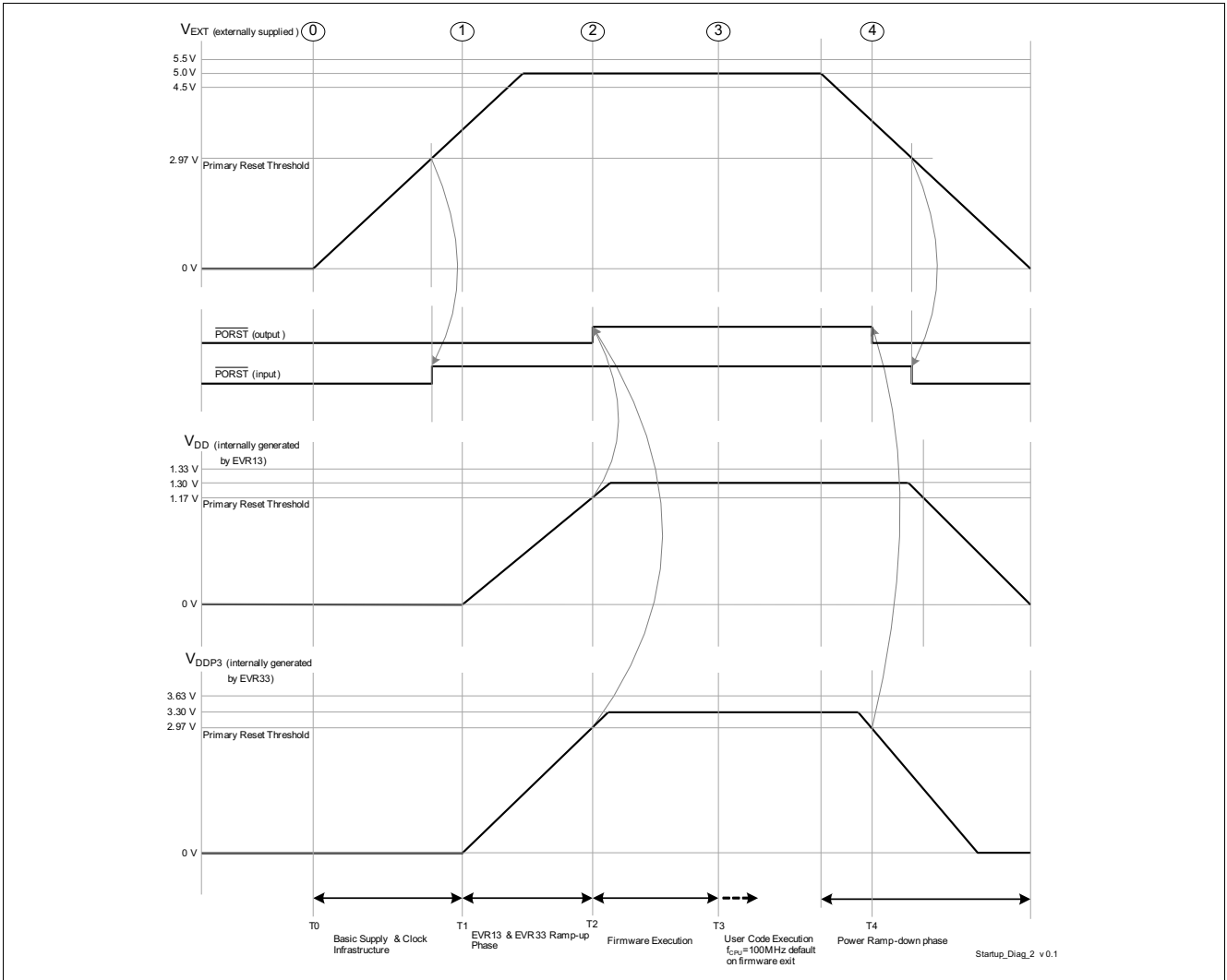

Figure 3-5 Single Supply Mode - 5 V single supply

3.15.3 External Supply Mode

All supplies, namely 5 V, 3.3 V & 1.3 V, are externally supplied.

- External supplies VEXT, VDDP3 & VDD may ramp-up or ramp-down independent of each other with regards to start, rise and fall time(s).
- The rate at which current is drawn from the external regulator (dI_{EXT}/dt , dI_{DD}/dt or dI_{DDP3}/dt) is limited in the Start-up phase to a maximum of 50 mA/100 μ s.
- PORST is active/asserted when either PORST (input) or PORST (output) is active/asserted.
- PORST (input) active means that the reset is held active by external agents by pulling the PORST pin low. It is recommended to keep the PORST (input) asserted until all the external supplies are above their primary reset thresholds.
- PORST (output) active means that μ C asserts the reset internally and drives the PORST pin low thus propagating the reset to external devices. The PORST (output) is asserted by the μ C when at least one among the three supply domains (1.3 V, 3.3 V or 5 V) violate their primary under-voltage reset thresholds. The PORST (output) is deasserted by the μ C when all supplies are above their primary reset thresholds and the basic supply and clock infrastructure is available.
- The power sequence as shown in [Figure 3-6](#) is enumerated below
 - T1 refers to the point in time when all supplies are above their primary reset thresholds and basic clock infrastructure is available. The supply mode is evaluated based on the HWCFG [0:2] pins. PORST (output) is deasserted and HWCFG [0:7] pins are latched on PORST rising edge. Firmware execution is initiated.
 - T2 refers to the point in time when Firmware execution is completed. User code execution starts with a default frequency of 100 MHz.
 - T3 refers to the point in time during the Ramp-down phase when at least one of the externally provided supplies (1.3 V, 3.3 V or 5 V) drop below their respective primary under-voltage reset thresholds.

Please note that there is no special requirements for $\overline{\text{PORST}}$ slew rates.

Electrical Specification Power-up and Power-down

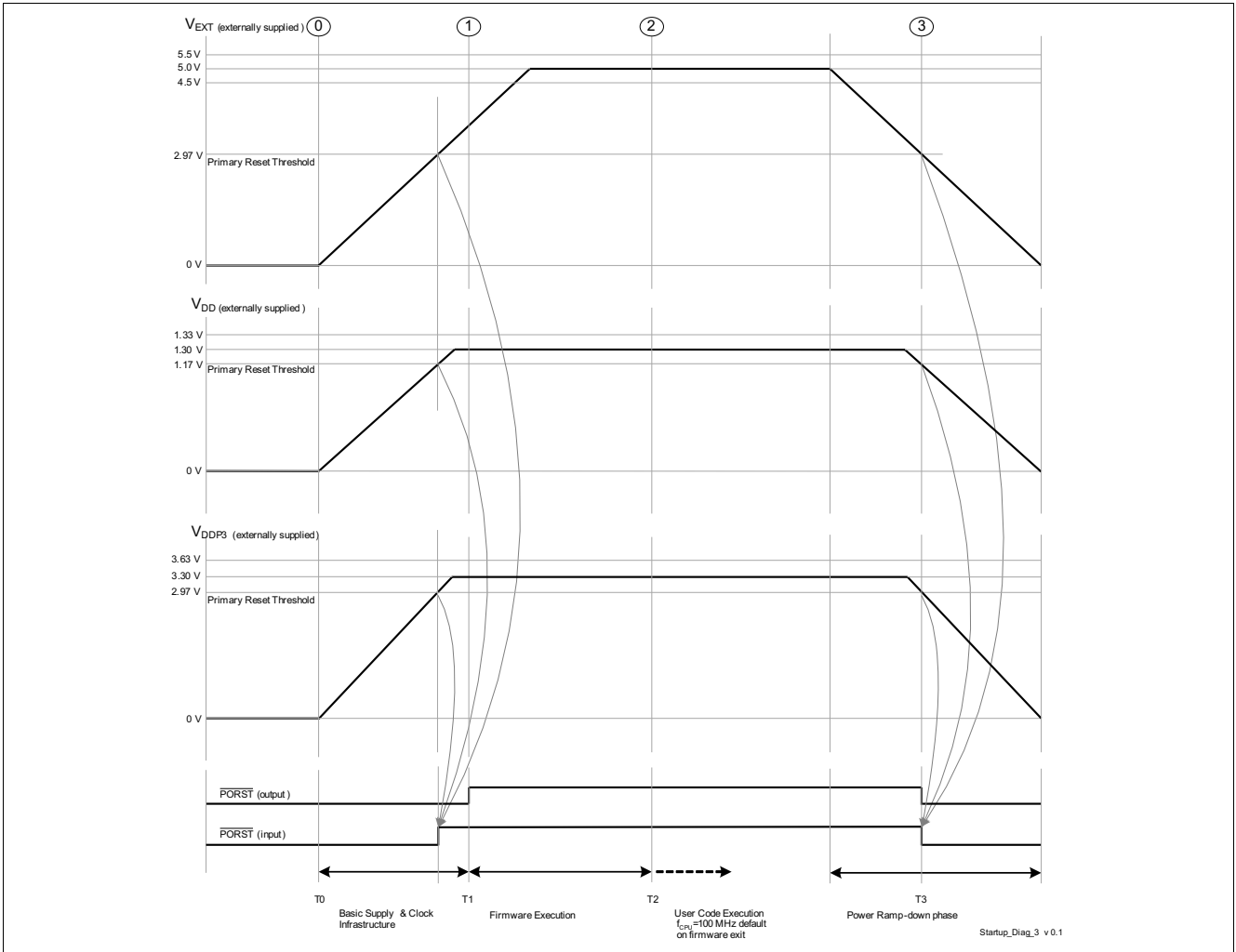

Figure 3-6 External Supply Mode - 5 V, 3.3 V & 1.3 V externally supplied

3.15.4 Single Supply Mode

3.3 V single supply mode. 1.3 V is generated internally by EVR13.

- The rate at which current is drawn from the external regulator (dI_{EXT}/dt) is limited in the Start-up phase to a maximum of 50 mA/100 μ s.
- PORST is active/asserted when either PORST (input) or PORST (output) is active/asserted.
- PORST (input) active means that the reset is held active by external agents by pulling the PORST pin low. It is recommended to keep the PORST (input) asserted until the external supply is above the respective primary reset threshold.
- PORST (output) active means that μ C asserts the reset internally and drives the PORST pin low thus propagating the reset to external devices. The PORST (output) is asserted by the μ C when at least one among the three supply domains (1.3 V or 3.3 V) violate their primary under-voltage reset thresholds. The PORST (output) is deasserted by the μ C when all supplies are above their primary reset thresholds and the basic supply and clock infrastructure is available.
- The power sequence as shown in [Figure 3-7](#) is enumerated below
 - T1 refers to the point in time when basic supply and clock infrastructure is available as the external supply ramps up. The supply mode is evaluated based on the HWCFG [0:2] pins and consequently a soft start of EVR13 regulator is initiated.
 - T2 refers to the point in time when all supplies are above their primary reset thresholds. EVR13 regulator has ramped up. PORST (output) is deasserted and HWCFG [0:7] pins are latched on PORST rising edge. Firmware execution is initiated.
 - T3 refers to the point in time when Firmware execution is completed. User code execution starts with a default frequency of 100 MHz.
 - T4 refers to the point in time during the Ramp-down phase when at least one of the externally provided or generated supplies (1.3 V or 3.3 V) drop below their respective primary under-voltage reset thresholds.

Please note that there is no special requirements for $\overline{\text{PORST}}$ slew rates.

Electrical Specification Power-up and Power-down

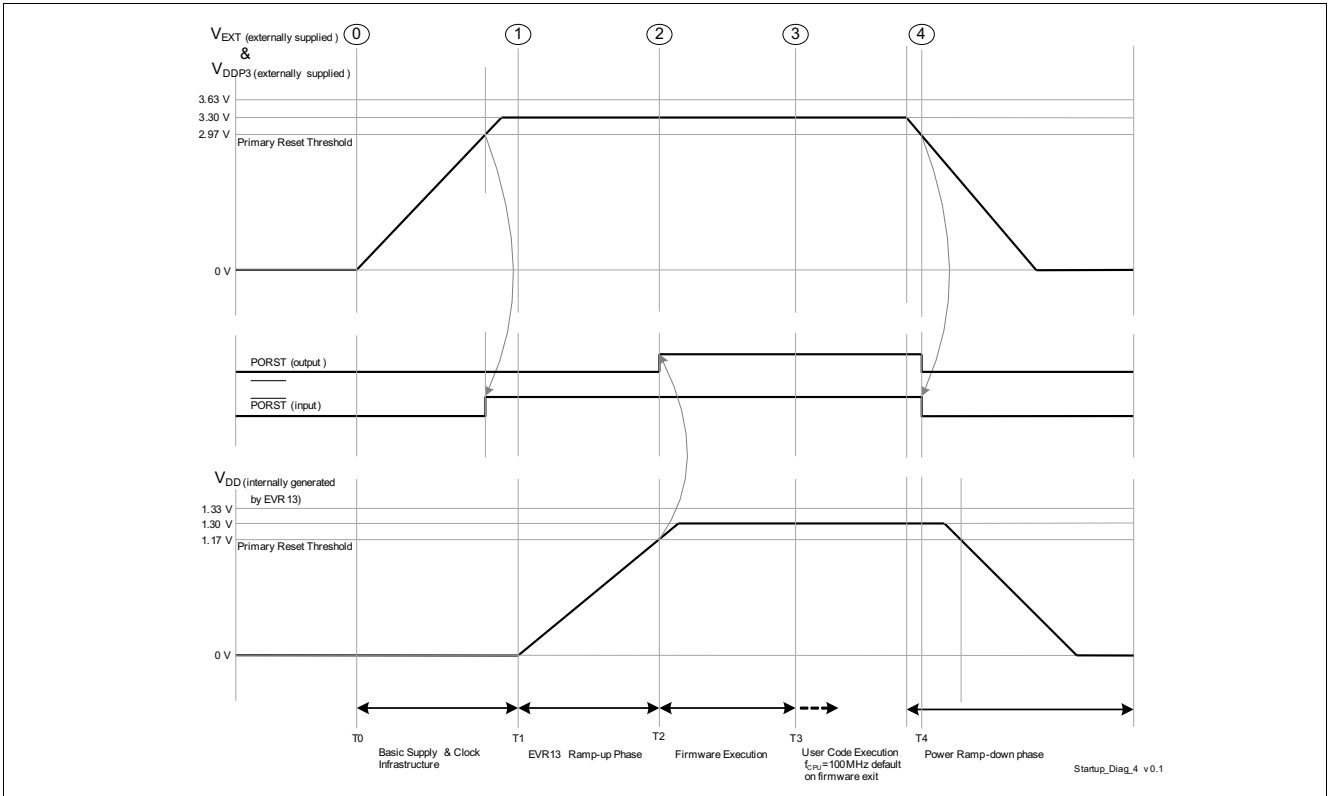

Figure 3-7 Single Supply Mode - 3.3 V single supply

3.16 Reset Timing

Table 3-35 Reset Timings

Parameter	Symbol	Values			Unit	Note / Test Condition
		Min.	Typ.	Max.		
Application Reset Boot Time ¹⁾	t_B CC	-	-	350 ²⁾	μs	operating with max. frequencies.
System Reset Boot Time	t_{BS} CC	-	-	1 ²⁾	ms	
Power on Reset Boot Time ³⁾	t_{BP} CC	-	-	2.5	ms	$dV/dT=1V/ms.$ including EVR ramp-up and Firmware execution time
		-	-	1.1 ²⁾	ms	Firmware execution time; without EVR operation (external supply only)
Minimum PORST hold time incase of power fail event issued by EVR primary monitor	t_{EVRPOR} CC	10	-	-	μs	
EVR start-up or ramp-up time	$t_{EVRstartup}$ CC	-	-	1	ms	$dV/dT=1V/ms.$ EVR13 and EVR33 active
Minimum PORST active hold time after power supplies are stable at operating levels ⁴⁾	t_{POA} CC	1	-	-	ms	
Configurable PORST digital filter delay in addition to analog pad filter delay	$t_{PORSTDF}$ CC	600	-	1200	ns	
HWCFG pins hold time from ESR0 rising edge	t_{HDH} CC	$16 / f_{SPB}$	-	-	ns	
HWCFG pins setup time to ESR0 rising edge	t_{HDS} CC	0	-	-	ns	
Ports inactive after ESR0 reset active	t_{PI} CC	-	-	$8/f_{SPB}$	ns	
Ports inactive after PORST reset active ⁵⁾	t_{PIP} CC	-	-	150	ns	
Hold time from PORST rising edge	t_{POH} SR	150	-	-	ns	
Setup time to PORST rising edge	t_{POS} SR	0	-	-	ns	
SCR reset boot time	t_{SCR} CC	-	-	300	μs	User Mode 0
		-	-	300	μs	User Mode 1
		-	13.3	-	μs	WDT double bit ECC, soft reset

Electrical Specification Reset Timing

- 1) The duration of the boot time is defined between the rising edge of the internal application reset and the clock cycle when the first user instruction has entered the CPU pipeline and its processing starts.
- 2) The timing values assumes programmed BMI with ESR0CNT inactive.
- 3) The duration of the boot time is defined by all external supply voltages are inside there operation conditions and the clock cycle when the first user instruction has entered the CPU pipeline and its processing starts.
- 4) The regulator that supplies V_{EXT} should ensure that V_{EXT} is in the operational region before PORST is externally released by the regulator. Incase of 5V nominal supply, it should be ensured that $V_{EXT} > 4V$ before PORST is released. Incase of 3.3V nominal supply, it should be ensured that $V_{EXT} > 3V$ before PORST is released. The additional minimum PORST hold time is required as an additional mechanism to avoid consecutive PORST toggling owing to slow supply slopes or residual supply ramp-ups. It is also required to activate external PORST atleast 100us before power-fail is recognised to avoid consecutive PORST toggling on a power fail event.
- 5) This parameter includes the delay of the analog spike filter in the \overline{PORST} pad.

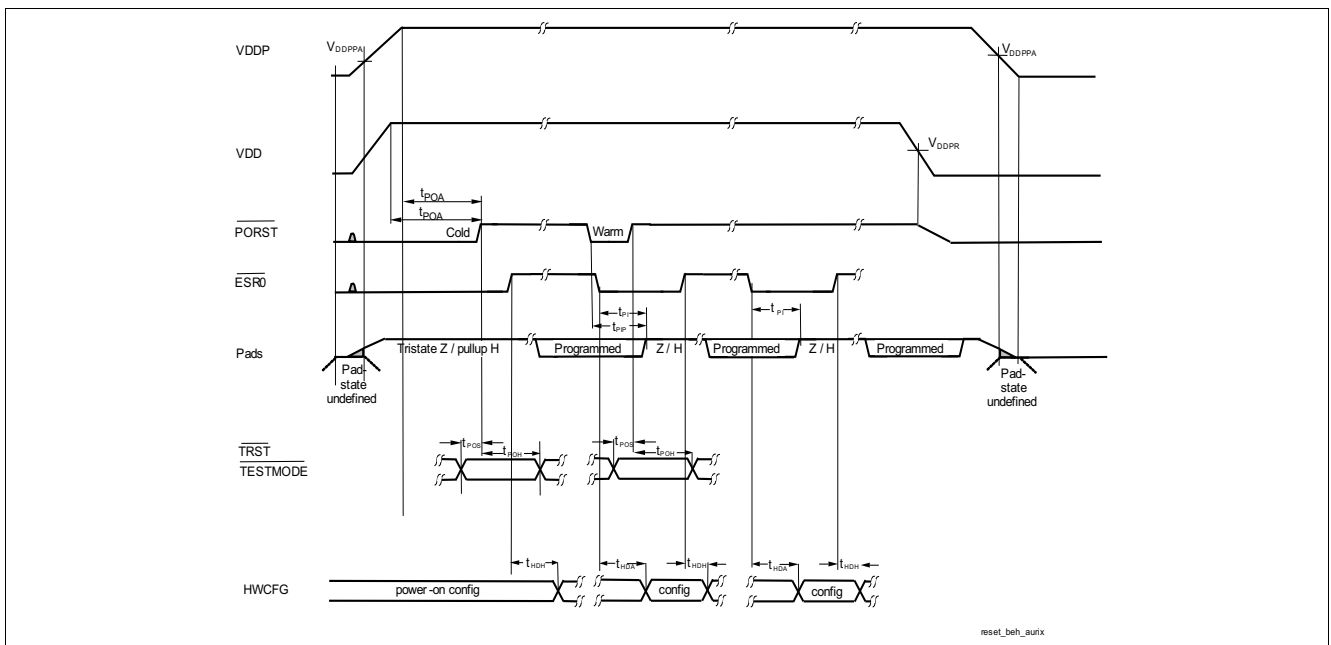
Figure 3-8 Power, Pad and Reset Timing

3.17 EVR

Table 3-36 3.3V

Parameter	Symbol	Values			Unit	Note / Test Condition
		Min.	Typ.	Max.		
Input voltage range ¹⁾	V_{IN} SR	4	-	5.50	V	pass device=on chip
Output voltage operational range including load/line regulation and aging incase of LDO regulator	V_{OUT} CC	2.97	3.3	3.63	V	pass device=on chip
Output V_{DDx3} static voltage accuracy after trimming and aging without dynamic load/line Regulation incase of LDO regulator.	V_{OUTT} CC	3.225	3.3	3.375	V	pass device=on chip
Output buffer capacitance on V_{OUT} ²⁾	C_{OUT} CC	-	1	-	μ F	pass device=on chip
Primary Undervoltage Reset threshold for V_{DDx3} ³⁾	V_{RST33} CC	-	-	3.0	V	by reset release before EVR trimming on supply ramp-up.
Startup time	t_{STR} CC	-	-	1000	μ s	pass device=on chip
External V_{IN} supply ramp ⁴⁾	dV_{in}/dT SR	-	1	50	V/ms	pass device=on chip
Load step response	dV_{out}/dI_{out} CC	-	-	240	mV	$dI=-70mA/20ns$; $T_{settle}=20us$; pass device=on chip
		-240	-	-	mV	$dI=50mA/20ns$; $T_{settle}=100us$; pass device=on chip
Line step response	dV_{out}/dV_{in} CC	-20	-	20	mV	$dV/dT=1V/ms$; pass device=on chip

- 1) A maximum pass device dropout voltage of 700mV is included in the minimum input voltage to ensure optimal pass device operation.
- 2) It is recommended to select a capacitor with ESR less than 50 mOhm (0.5MHz - 10 MHz). It is also recommended that the resistance of the supply trace from the pin to the EVR output capacitor is less than 100 mOhm.
- 3) The reset release on supply ramp-up is delayed by a time duration 20-40 us after reaching undervoltage reset threshold. This serves as a time hysteresis to avoid multiple consecutive cold PORST events during slow supply ramp-ups owing to voltage drop/current jumps when reset is released. The reset limit of 2.97V at pin is for the case with 3.3V generated internally from EVR33. In case the 3.3V supply is provided externally, the bondwire drop will cause a reset at a higher voltage of 3.0V at the V_{DDP3} pin.
- 4) EVR robust against residual voltage ramp-up starting between 0-1 V.

Table 3-37 1.3V

Parameter	Symbol	Values			Unit	Note / Test Condition
		Min.	Typ.	Max.		
Input voltage range ¹⁾	V_{IN} SR	2.97	-	5.5	V	$V_{IN} \geq$; pass device=on chip
		2.97	-	5.5	V	pass device=off chip
Output voltage operational range including load/line regulation and aging incase of LDO regulator	V_{OUT} CC	1.17	1.3	1.43	V	$V_{IN} \geq$; pass device=on chip
		1.17	1.3	1.43	V	pass device=off chip
Output V_{DD} static voltage accuracy after trimming without dynamic load/line regulation with aging incase of LDO regulator.	V_{OUTT} CC	1.275	1.3	1.325	V	$V_{IN} \geq$; pass device=on chip
		1.275	1.3	1.325	V	pass device=off chip
Output buffer capacitance on V_{OUT} ²⁾	C_{OUT} CC	1.4	2.2	3	μ F	On chip pass device usage restricted to $I_{DD} < 200$ mA. If $I_{DD} > 200$ mA, off chip pass device to be used.; $V_{IN} \geq$; pass device=on chip
		3	4.7	6.3	μ F	pass device=off chip
Primary undervoltage reset threshold for V_{DD} ³⁾	V_{RST13} CC	-	-	1.17	V	$V_{IN} \geq$; pass device=on chip
		-	-	1.17	V	by reset release before EVR trimming on supply ramp-up. pass device=off chip
Startup time	t_{STR} CC	-	-	1000	μ s	$V_{IN} \geq$; pass device=on chip
		-	-	1000	μ s	pass device=off chip
External V_{IN} supply ramp ⁴⁾	dV_{in}/dT SR	-	1	50	V/ms	$V_{IN} \geq$; pass device=on chip
		-	1	50	V/ms	pass device=off chip

Table 3-37 1.3V (cont'd)

Parameter	Symbol	Values			Unit	Note / Test Condition
		Min.	Typ.	Max.		
Load step response	dV_{out}/dI_{out} CC	-	-	100	mV	$dI=-125mA$; $T_{settle}=20\mu s$; $V_{IN}\geq$; pass device=on chip
		-	-	100	mV	$dI=-150mA$; $T_{settle}=20\mu s$; pass device=off chip
		-100	-	-	mV	$dI=100mA$; $T_{settle}=20\mu s$; pass device=off chip
		-100	-	-	mV	$dI=75mA$; $T_{settle}=20\mu s$; $V_{IN}\geq$; pass device=on chip
Line step response	dV_{out}/dV_{in} CC	-10	-	10	mV	$dV/dT=1V/ms$; $V_{IN}\geq$; pass device=on chip
		-10	-	10	mV	$dV/dT=1V/ms$; pass device=off chip

- 1) A maximum pass device dropout voltage of 700mV is included in the minimum input voltage to ensure optimal pass device operation.
- 2) It is recommended to select a capacitor with ESR less than 50 mOhm (0.5MHz - 10 MHz). It is also recommended that the resistance of the supply trace from the pin to the EVR output capacitor is less than 100 mOhm.
- 3) The reset release on supply ramp-up is delayed by a time duration 30-60 μs after reaching undervoltage reset threshold. This serves as a time hysteresis to avoid multiple consecutive cold PORST events during slow supply ramp-ups owing to voltage drop/current jumps when reset is released. The reset limit of 1,17V at pin is for the case with 1.3V generated internally from EVR13. In case the 1.3V supply is provided externally, the bondwire drop will cause a reset at a higher voltage of 1.18V at the VDD pin.
- 4) EVR robust against residual voltage ramp-up starting between 0-1 V.

Table 3-38 Supply Monitoring

Parameter	Symbol	Values			Unit	Note / Test Condition
		Min.	Typ.	Max.		
V_{EXT} primary undervoltage monitor accuracy after trimming ¹⁾	$V_{EXTPRIUV}$ SR	2.86	2.92	2.97	V	V_{EXT} = Undervoltage Reset Threshold
V_{DDP3} primary undervoltage monitor accuracy after trimming ¹⁾	$V_{DDP3PRIUV}$ SR	2.86	2.90	2.97	V	V_{DDP3} = Undervoltage Reset Threshold
V_{DD} primary undervoltage monitor accuracy after trimming ¹⁾	$V_{DDPRIUV}$ SR	1.13	1.15	1.17	V	V_{DD} = Undervoltage Reset Threshold
V_{EXT} secondary supply monitor accuracy	V_{EXTMON} CC	4.9	5.0	5.1	V	SWDxxVAL V_{EXT} monitoring threshold=5V=DBh

Table 3-38 Supply Monitoring (cont'd)

Parameter	Symbol	Values			Unit	Note / Test Condition
		Min.	Typ.	Max.		
V_{DDP3} secondary supply monitor accuracy	$V_{DDP3MON}$ CC	3.23	3.30	3.37	V	EVR33xxVAL V_{DDP3} monitoring threshold=3.3V=91h
V_{DD} secondary supply monitor accuracy	V_{DDMON} CC	1.27	1.30	1.33	V	EVR13xxVAL V_{DD} monitoring threshold=1.3V=E4h
EVR primary and secondary monitor measurement latency for a new supply value	t_{EVRMON} CC	-	-	1.8	μ s	after trimming

1) The monitor tolerances constitute the inherent variation of the bandgap and ADC over process, voltage and temperature operational ranges. The xxxPRIUV parameters are device individually tested in production with $\pm 1\%$ tolerance about the min and max xxxPRIUV limits. In TQFP100 and QFP80 pin packages, VDDPRIUV is not tested as HWCFG2 pin is absent.

Table 3-39 EVR13 SMPS External components

Parameter	Symbol	Values			Unit	Note / Test Condition
		Min.	Typ.	Max.		
External output capacitor value ¹⁾	C_{OUTDC} SR	15.4	22	29.7	μ F	$I_{DDDC}=1A$
		6.5	10	13.5	μ F	$I_{DDDC}=400mA$
External output capacitor ESR	C_{DC_ESR} SR	-	-	50	mOhm	$f \geq 0.5MHz; f \leq 10MHz$
		-	-	100	Ohm	$f = 10Hz$
External input capacitor value ¹⁾	C_{IN} SR	6.5	10	13.5	μ F	$I_{DDDC}=1A$
		4.42	6.8	9.18	μ F	$I_{DDDC}=400mA$
External input capacitor ESR	C_{IN_ESR} SR	-	-	50	mOhm	$f \geq 0.5MHz; f \leq 10MHz$
		-	-	100	Ohm	$f = 100Hz$
External inductor value ²⁾	L_{DC} SR	2.31	3.3	4.29	μ H	$f_{DCDC}=1.5MHz$
		3.29	4.7	6.11	μ H	$f_{DCDC}=1MHz$
External inductor ESR	L_{DC_ESR} SR	-	-	0.2	Ohm	
P + N-channel MOSFET logic level	V_{LL} SR	-	-	2.5	V	
P + N-channel MOSFET drain source breakdown voltage	$ V_{BR_DS} $ SR	-	-	7	V	
P + N-channel MOSFET drain source ON-state resistance	R_{ON} SR	-	-	150	mOhm	$I_{DDDC}=1A; V_{GS}=2.5V; T_A=25^\circ C$
		-	-	200	mOhm	$I_{DDDC}=400mA; V_{GS}=2.5V; T_A=25^\circ C$
P + N-channel MOSFET Gate Charge	Q_{ac} SR	-	4	-	nC	$I_{DDDC}=1A; MOS-V_{GS}=5V$
		-	8	-	nC	$I_{DDDC}=400mA; MOS-V_{GS}=5V$

Table 3-39 EVR13 SMPS External components (cont'd)

Parameter	Symbol	Values			Unit	Note / Test Condition
		Min.	Typ.	Max.		
External MOSFET commutation time	t_c SR	10	30	40	ns	configurable
N-channel MOSFET reverse diode forward voltage	V_{RDN} SR	-	0.8	-	V	

- 1) Capacitor min-max range represent typical $\pm 35\%$ tolerance including DC bias effect. The trace resistance from the capacitor to the supply or ground rail should be limited to 25 mOhm.
- 2) External inductor min-max range represent typical $\pm 30\%$ tolerance at a DC bias current of 100mA.

Table 3-40 EVR13 SMPS

Parameter	Symbol	Values			Unit	Note / Test Condition
		Min.	Typ.	Max.		
Input V_{EXT} Voltage range	V_{IN} SR	2.97	-	5.5	V	
SMPS regulator output voltage range including load/line regulation and aging ¹⁾	V_{DDDC} CC	1.17	-	1.43	V	$V_{DD} \geq 2.97V$; $V_{DD} \leq 5.5V$; $I_{DDDC} \geq 1mA$; $I_{DDDC} \leq 1A$
SMPS regulator static voltage output accuracy after trimming without dynamic load/line Regulation with aging. ²⁾	V_{DDDCCT} CC	1.275	1.3	1.325	V	$V_{DD} \geq 2.97V$; $V_{DD} \leq 5.5V$; $I_{DDDC} \geq 1mA$; $I_{DDDC} \leq 1A$
Programmable switching frequency	f_{DCDC} CC	0.4	-	2.0	MHz	
Switching frequency modulation spread	Δf_{DCSPR} CC	-	-	2%	MHz	
Maximum ripple at I_{MAX} (peak-to-peak) ³⁾	ΔV_{DDDC} CC	-	-	15	mV	$V_{DD} \geq 2.97V$; $V_{DD} \leq 5.5V$; $I_{DDDC} \geq 300mA$; $I_{DDDC} \leq 1A$
No load current consumption of SMPS regulator	I_{DCNL} CC	-	5	10	mA	$f_{DCDC} = 1MHz$
SMPS regulator load transient response	dV_{out}/dI_{out} CC	-25	-	25	mV	$dI < 200mA$; $f_{DCDC} = 1MHz$; $t_r = 0.1us$; $t_f = 0.1us$; $V_{DDDC} = 1.3V$
		-65	-	65	mV	$dI < 400mA$; $f_{DCDC} = 1MHz$; $t_r = 0.1us$; $t_f = 0.1us$; $V_{DDDC} = 1.3V$
Maximum output current of the regulator	I_{MAX} SR	-	-	1	A	limited by thermal constraints and component choice

Table 3-40 EVR13 SMPS (cont'd)

Parameter	Symbol	Values			Unit	Note / Test Condition
		Min.	Typ.	Max.		
SMPS regulator efficiency	n_{DC} CC	-	85	-	%	$V_{IN}=3.3V$; $I_{DDDC}=300mA$; $f_{DCDC}=1MHz$
		-	75	-	%	$V_{IN}=5V$; $I_{DDDC}=400mA$; $f_{DCDC}=1.5MHz$
		-	80	-	%	$V_{IN}=5V$; $I_{DDDC}=400mA$; $f_{DCDC}=1MHz$

- 1) In case of SMPS mode, it shall be ensured that the V_{DD} output pin shall be connected on PCB level to all other V_{DD} Input pins.
- 2) In case of f_{SR1} running with max frequency, it shall be ensured that the V_{DD} operating range is limited to 1.235V upto 1.430V. The DCDC may be configured in this case with a nominal voltage of $1.33V \pm 7.5\%$. The static accuracy and regulation parameter ranges remain also valid for this case.
- 3) If frequency spreading (SDFREQSPRD = 1) is activated, an additional ripple of 1% need to be considered.

3.18 Phase Locked Loop (PLL)

Table 3-41 PLL

Parameter	Symbol	Values			Unit	Note / Test Condition
		Min.	Typ.	Max.		
PLL base frequency	f_{PLLBASE} CC	80	150	360	MHz	
VCO frequency range	f_{VCO} SR	400	-	800	MHz	
VCO Input frequency range	f_{REF} CC	8	-	24	MHz	
Modulation Amplitude	MA CC	0	-	2	%	
Peak Period jitter	DP CC	-200	-	200	ps	
Peak Accumulated Jitter	D_{PP} CC	-5	-	5	ns	without modulation
Total long term jitter	J_{TOT} CC	-	-	11.5	ns	including modulation; $MA \leq 1\%$
System frequency deviation	f_{SYSD} CC	-	-	0.01	%	with active modulation
Modulation variation frequency	f_{MV} CC	2	3.6	5.4	MHz	
PLL lock-in time	t_{L} CC	11.5	-	200	μs	

Note: The specified PLL jitter values are valid if the capacitive load per pin does not exceed $C_L = 20 \text{ pF}$ with the maximum driver and sharp edge.

Note: The maximum peak-to-peak noise on the power supply voltage, is limited to a peak-to-peak voltage of $V_{\text{PP}} = 100 \text{ mV}$ for noise frequencies below 300 KHz and $V_{\text{PP}} = 40 \text{ mV}$ for noise frequencies above 300 KHz. These conditions can be achieved by appropriate blocking of the supply voltage as near as possible to the supply pins and using PCB supply and ground planes.

3.19 ERAY Phase Locked Loop (ERAY_PLL)

Table 3-42 PLL_ERAY

Parameter	Symbol	Values			Unit	Note / Test Condition
		Min.	Typ.	Max.		
PLL Base Frequency of the ERAY PLL	$f_{\text{PLLBASE_ERAY CC}}$	50	200	320	MHz	
VCO frequency range of the ERAY PLL	$f_{\text{VCO_ERAY SR}}$	400	-	480	MHz	
VCO input frequency of the ERAY PLL	$f_{\text{REF SR}}$	16	-	24	MHz	
Accumulated_Jitter	$D_{\text{p CC}}$	-0.5	-	0.5	ns	
Accumulated jitter at SYSCLK pin	$D_{\text{pp CC}}$	-0.8	-	0.8	ns	
PLL lock-in time	$t_{\text{L CC}}$	5.6	-	200	μs	

Note: The specified PLL jitter values are valid if the capacitive load per pin does not exceed $C_L = 20 \text{ pF}$ with the maximum driver and sharp edge.

Note: The maximum peak-to-peak noise on the power supply voltage, is limited to a peak-to-peak voltage of $V_{\text{pp}} = 100 \text{ mV}$ for noise frequencies below 300 KHz and $V_{\text{pp}} = 40 \text{ mV}$ for noise frequencies above 300 KHz. These conditions can be achieved by appropriate blocking of the supply voltage as near as possible to the supply pins and using PCB supply and ground planes.

3.20 AC Specifications

All AC parameters are specified for the complete operating range defined in [Chapter 3.4](#) unless otherwise noted in column Note / test Condition.

Unless otherwise noted in the figures the timings are defined with the following guidelines:

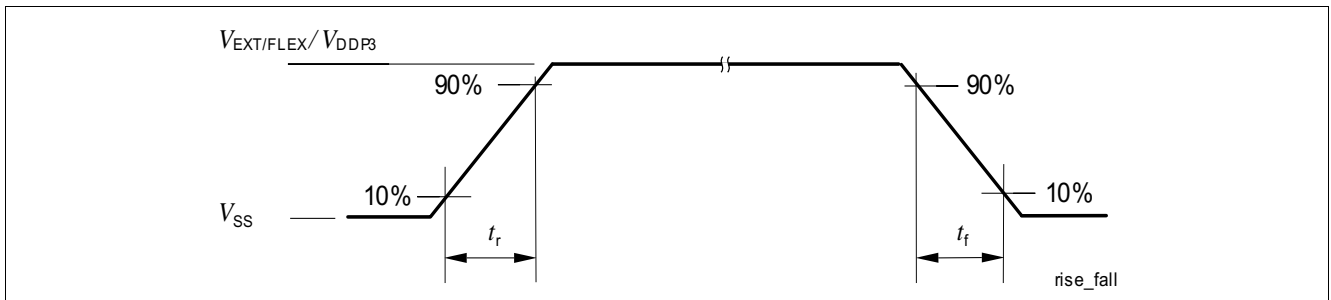

Figure 3-9 Definition of rise / fall times

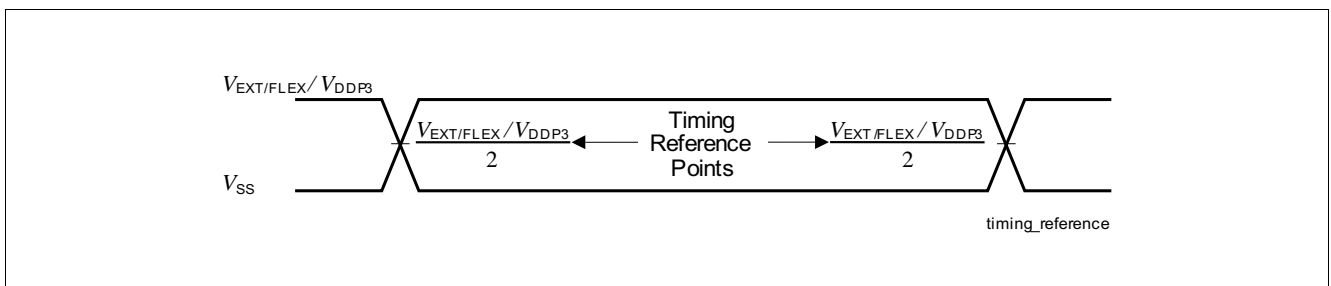

Figure 3-10 Time Reference Point Definition

3.21 JTAG Parameters

The following parameters are applicable for communication through the JTAG debug interface. The JTAG module is fully compliant with IEEE1149.1-2000.

Table 3-43 JTAG

Parameter	Symbol	Values			Unit	Note / Test Condition
		Min.	Typ.	Max.		
TCK clock period	t_1 SR	25	-	-	ns	
TCK high time	t_2 SR	10	-	-	ns	
TCK low time	t_3 SR	10	-	-	ns	
TCK clock rise time	t_4 SR	-	-	4	ns	
TCK clock fall time	t_5 SR	-	-	4	ns	
TDI/TMS setup to TCK rising edge	t_6 SR	6.0	-	-	ns	
TDI/TMS hold after TCK rising edge	t_7 SR	6.0	-	-	ns	
TDO valid after TCK falling edge (propagation delay) ¹⁾	t_8 CC	3.0	-	-	ns	$C_L \leq 20\text{pF}$
		-	-	16	ns	$C_L \leq 50\text{pF}$
TDO hold after TCK falling edge ¹⁾	t_{18} CC	2	-	-	ns	
TDO high impedance to valid from TCK falling edge ¹⁾²⁾	t_9 CC	-	-	17.5	ns	$C_L \leq 50\text{pF}$
TDO valid output to high impedance from TCK falling edge ¹⁾	t_{10} CC	-	-	17	ns	$C_L \leq 50\text{pF}$

1) The falling edge on TCK is used to generate the TDO timing.

2) The setup time for TDO is given implicitly by the TCK cycle time.

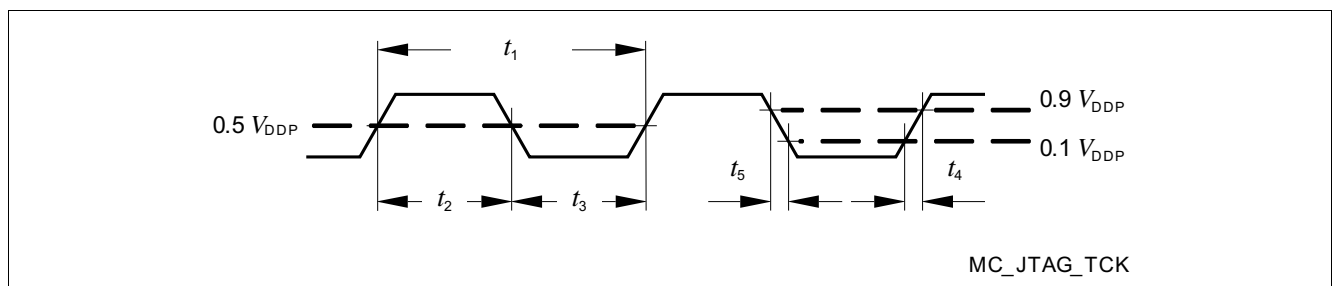

Figure 3-11 Test Clock Timing (TCK)

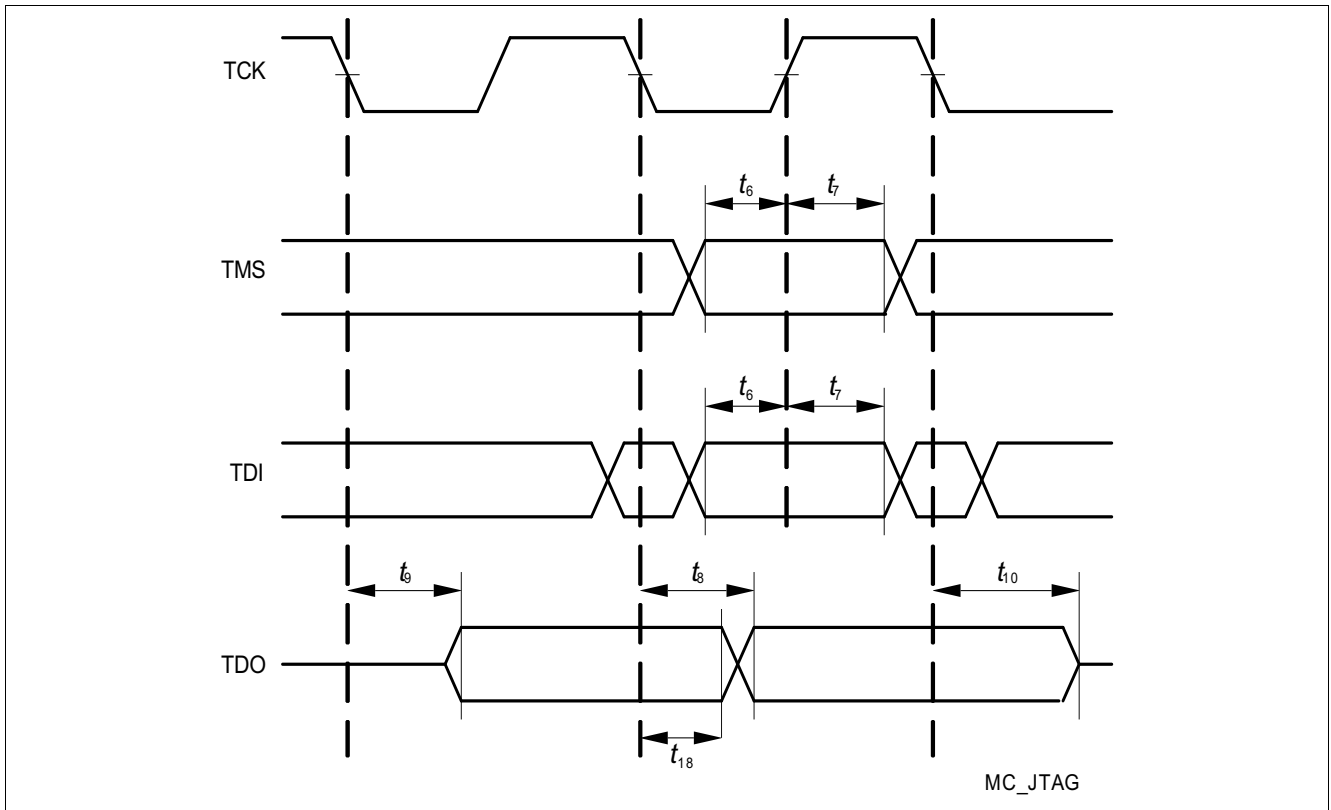

Figure 3-12 JTAG Timing

3.22 DAP Parameters

The following parameters are applicable for communication through the DAP debug interface.

Table 3-44 DAP

Parameter	Symbol	Values			Unit	Note / Test Condition
		Min.	Typ.	Max.		
DAP0 clock period	t_{11} SR	6.25	-	-	ns	
DAP0 high time	t_{12} SR	2	-	-	ns	
DAP0 low time	t_{13} SR	2	-	-	ns	
DAP0 clock rise time	t_{14} SR	-	-	1	ns	$f=160\text{MHz}$
		-	-	2	ns	$f=80\text{MHz}$
DAP0 clock fall time	t_{15} SR	-	-	1	ns	$f=160\text{MHz}$
		-	-	2	ns	$f=80\text{MHz}$
DAP1 setup to DAP0 rising edge	t_{16} SR	4	-	-	ns	
DAP1 hold after DAP0 rising edge	t_{17} SR	2	-	-	ns	
DAP1 valid per DAP0 clock period ¹⁾	t_{19} CC	3	-	-	ns	$C_L=20\text{pF}; f=160\text{MHz}$
		8	-	-	ns	$C_L=20\text{pF}; f=80\text{MHz}$
		10	-	-	ns	$C_L=50\text{pF}; f=40\text{MHz}$

1) The Host has to find a suitable sampling point by analyzing the sync telegram response.

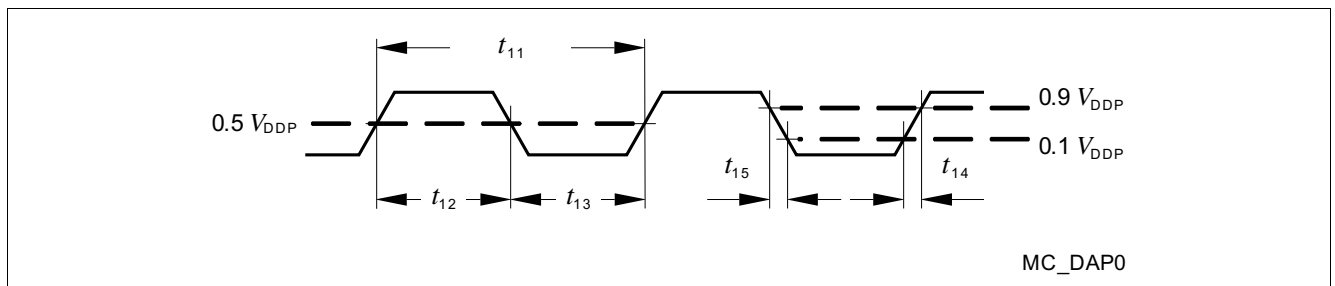

Figure 3-13 Test Clock Timing (DAP0)

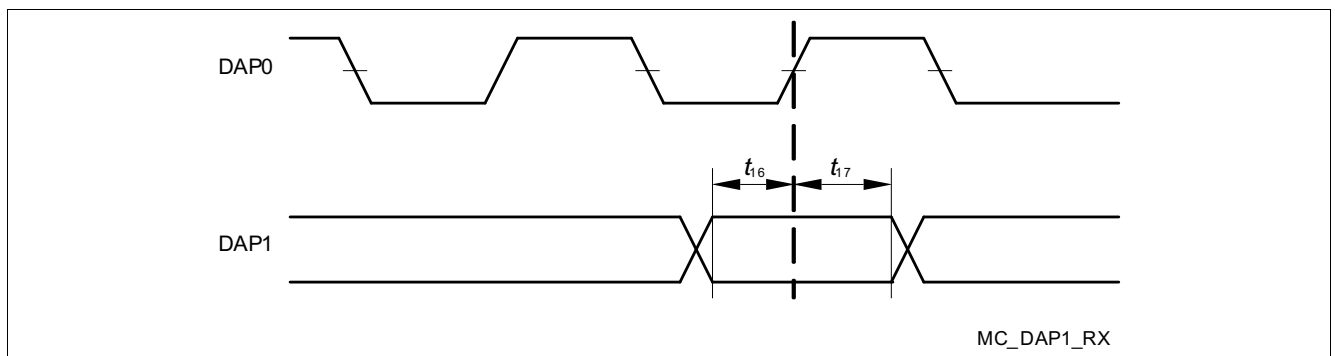

Figure 3-14 DAP Timing Host to Device

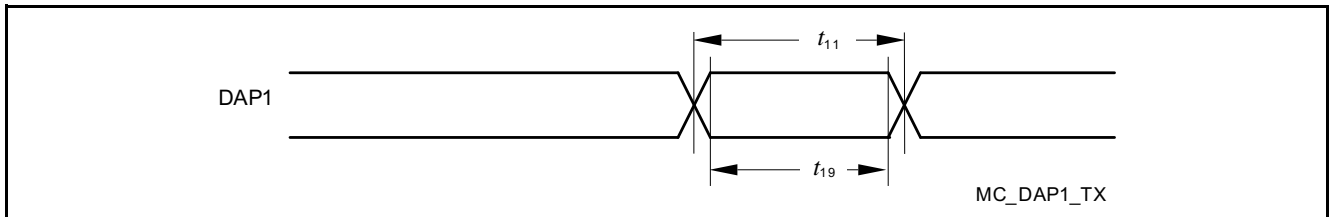

Figure 3-15 DAP Timing Device to Host (DAP1 and DAP2 pins)

Note: The DAP1 and DAP2 device to host timing is individual for both pins. There is no guaranteed max. signal skew.

3.23 ASCLIN SPI Master Timing

This section defines the timings for the ASCLIN in the TC 260 / 264 / 265 / 267, for 5V power supply.

Note: Pad asymmetry is already included in the following timings.

Table 3-45 Master Mode MP+ss/MPRss output pads

Parameter	Symbol	Values			Unit	Note / Test Condition
		Min.	Typ.	Max.		
ASCLKO clock period ¹⁾	t_{50} CC	20	-	-	ns	$C_L=25\text{pF}$
Deviation from ideal duty cycle ²⁾	t_{500} CC	-3	-	3	ns	$0 < C_L < 50\text{pF}$
MISR delay from ASCLKO shifting edge	t_{51} CC	-7	-	6	ns	$C_L=25\text{pF}$
ASLSON delay from the first ASCLKO edge	t_{510} CC	5	-	35	ns	$C_L=25\text{pF}$; pad used = LPm
MRST setup to ASCLKO latching edge	t_{52} SR	28	-	-	ns	$C_L=25\text{pF}$
MRST hold from ASCLKO latching edge	t_{53} SR	-6	-	-	ns	$C_L=25\text{pF}$

- 1) PLL Jitter not included. Should be considered additionally, corresponding to the used baudrate. The duty cycle can be adjusted using the BITCON.SAMPLEPOINT bitfield with the finest granularity of $T_{MAX} = 1 / f_{MAX}$.
- 2) Positive deviation lengthens the high time and shortens the low time of a clock period. Negative deviation does the opposite.

Table 3-46 Master Mode MPss output pads

Parameter	Symbol	Values			Unit	Note / Test Condition
		Min.	Typ.	Max.		
ASCLKO clock period ¹⁾	t_{50} CC	20	-	-	ns	$C_L=25\text{pF}$
Deviation from ideal duty cycle ²⁾	t_{500} CC	-2	-	$3.5+0.035 * C_L$	ns	$0 < C_L < 200\text{pF}$
MISR delay from ASCLKO shifting edge	t_{51} CC	-7	-	6	ns	$C_L=25\text{pF}$
ASLSON delay from the first ASCLKO edge	t_{510} CC	-7	-	6	ns	$C_L=25\text{pF}$
MRST setup to ASCLKO latching edge	t_{52} SR	30	-	-	ns	$C_L=25\text{pF}$, else
		33 ³⁾	-	-	ns	$C_L=25\text{pF}$, for P14.2, P14.4, and P15.1
MRST hold from ASCLKO latching edge	t_{53} SR	-5	-	-	ns	$C_L=25\text{pF}$

- 1) PLL Jitter not included. Should be considered additionally, corresponding to the used baudrate. The duty cycle can be adjusted using the BITCON.SAMPLEPOINT bitfield with the finest granularity of $T_{MAX} = 1 / f_{MAX}$.
- 2) Positive deviation lengthens the high time and shortens the low time of a clock period. Negative deviation does the opposite.
- 3) Please note that these pins didn't support the hysteresis inactive feature.

Electrical Specification ASCLIN SPI Master Timing

Table 3-47 Master Mode MPsm output pads

Parameter	Symbol	Values			Unit	Note / Test Condition
		Min.	Typ.	Max.		
ASCLKO clock period ¹⁾	t_{50} CC	100	-	-	ns	$C_L=50\text{pF}$
Deviation from ideal duty cycle ²⁾	t_{500} CC	-3	-	$4+0.04 * C_L$	ns	$0 < C_L < 200\text{pF}$
MTSR delay from ASCLKO shifting edge	t_{51} CC	-11	-	10	ns	$C_L=50\text{pF}$
ASLSON delay from the first ASCLKO edge	t_{510} CC	-11	-	10	ns	$C_L=50\text{pF}$
MRST setup to ASCLKO latching edge	t_{52} SR	60	-	-	ns	$C_L=50\text{pF}$
MRST hold from ASCLKO latching edge	t_{53} SR	-10	-	-	ns	$C_L=50\text{pF}$

- 1) PLL Jitter not included. Should be considered additionally, corresponding to the used baudrate. The duty cycle can be adjusted using the BITCON.SAMPLEPOINT bitfield with the finest granularity of $T_{MAX} = 1 / f_{MAX}$.
- 2) Positive deviation lengthens the high time and shortens the low time of a clock period. Negative deviation does the opposite.

Table 3-48 Master Mode medium output pads

Parameter	Symbol	Values			Unit	Note / Test Condition
		Min.	Typ.	Max.		
ASCLKO clock period ¹⁾	t_{50} CC	200	-	-	ns	$C_L=50\text{pF}$
Deviation from ideal duty cycle ²⁾	t_{500} CC	-8	-	$4+0.04 * C_L$	ns	$0 < C_L < 200\text{pF}$
MTSR delay from ASCLKO shifting edge	t_{51} CC	-20	-	15	ns	$C_L=50\text{pF}$
ASLSON delay from the first ASCLKO edge	t_{510} CC	-20	-	20	ns	$C_L=50\text{pF}$
MRST setup to ASCLKO latching edge	t_{52} SR	70	-	-	ns	$C_L=50\text{pF}$
MRST hold from ASCLKO latching edge	t_{53} SR	-10	-	-	ns	$C_L=50\text{pF}$

- 1) PLL Jitter not included. Should be considered additionally, corresponding to the used baudrate. The duty cycle can be adjusted using the BITCON.SAMPLEPOINT bitfield with the finest granularity of $T_{MAX} = 1 / f_{MAX}$.
- 2) Positive deviation lengthens the high time and shortens the low time of a clock period. Negative deviation does the opposite.

Table 3-49 Master Mode weak output pads

Parameter	Symbol	Values			Unit	Note / Test Condition
		Min.	Typ.	Max.		
ASCLKO clock period ¹⁾	t_{50} CC	1000	-	-	ns	$C_L=50\text{pF}$
Deviation from ideal duty cycle ²⁾	t_{500} CC	-30	-	$30+0.15 * C_L$	ns	$0 < C_L < 200\text{pF}$

Table 3-49 Master Mode weak output pads (cont'd)

Parameter	Symbol	Values			Unit	Note / Test Condition
		Min.	Typ.	Max.		
MTSR delay from ASCLKO shifting edge	t_{51} CC	-75	-	75	ns	$C_L=50\text{pF}$
ASLSON delay from the first ASCLKO edge	t_{510} CC	-65	-	65	ns	$C_L=50\text{pF}$
MRST setup to ASCLKO latching edge	t_{52} SR	510	-	-	ns	$C_L=50\text{pF}$
MRST hold from ASCLKO latching edge	t_{53} SR	-50	-	-	ns	$C_L=50\text{pF}$

- 1) PLL Jitter not included. Should be considered additionally, corresponding to the used baudrate. The duty cycle can be adjusted using the BITCON.SAMPLEPOINT bitfield with the finest granularity of $T_{MAX} = 1 / f_{MAX}$.
- 2) Positive deviation lengthens the high time and shortens the low time of a clock period. Negative deviation does the opposite.

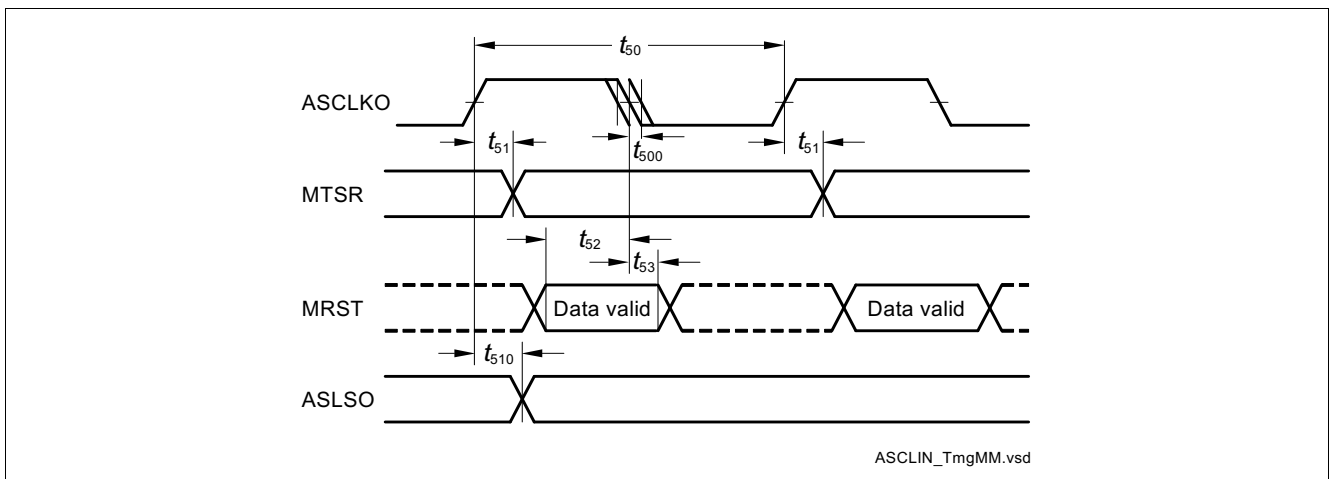
Figure 3-16 ASCLIN SPI Master Timing

3.24 ASCLIN SPI Master Timing

This section defines the timings for the ASCLIN in the TC 260 / 264 / 265 / 267, for 3.3V power supply, Medium Performance pads, strong sharp edge (MPss), $C_L=25\text{pF}$.

Note: Pad asymmetry is already included in the following timings.

Table 3-50 Master Mode MP+ss/MPRss output pads

Parameter	Symbol	Values			Unit	Note / Test Condition
		Min.	Typ.	Max.		
ASCLKO clock period ¹⁾	t_{50} CC	40	-	-	ns	$C_L=25\text{pF}$
Deviation from ideal duty cycle ²⁾	t_{500} CC	-5	-	5	ns	$0 < C_L < 50\text{pF}$
MTSR delay from ASCLKO shifting edge	t_{51} CC	-12	-	12	ns	$C_L=25\text{pF}$
ASLSON delay from the first ASCLKO edge	t_{510} CC	0	-	60	ns	$C_L=25\text{pF}$; pad used = LPm
MRST setup to ASCLKO latching edge	t_{52} SR	50	-	-	ns	$C_L=25\text{pF}$
MRST hold from ASCLKO latching edge	t_{53} SR	-5	-	-	ns	$C_L=25\text{pF}$

1) PLL Jitter not included. Should be considered additionally, corresponding to the used baudrate. The duty cycle can be adjusted using the BITCON.SAMPLEPOINT bitfield with the finest granularity of $T_{MAX} = 1 / f_{MAX}$.

2) Positive deviation lengthens the high time and shortens the low time of a clock period. Negative deviation does the opposite.

Table 3-51 Master Mode MPss output pads

Parameter	Symbol	Values			Unit	Note / Test Condition
		Min.	Typ.	Max.		
ASCLKO clock period ¹⁾	t_{50} CC	40	-	-	ns	$C_L=25\text{pF}$
Deviation from ideal duty cycle ²⁾	t_{500} CC	-5	-	$7+0.07 * C_L$	ns	$0 < C_L < 200\text{pF}$
MTSR delay from ASCLKO shifting edge	t_{51} CC	-12	-	12	ns	$C_L=25\text{pF}$
ASLSON delay from the first ASCLKO edge	t_{510} CC	-12	-	12	ns	$C_L=25\text{pF}$
MRST setup to ASCLKO latching edge	t_{52} SR	50	-	-	ns	$C_L=25\text{pF}$
MRST hold from ASCLKO latching edge	t_{53} SR	-5	-	-	ns	$C_L=25\text{pF}$

1) PLL Jitter not included. Should be considered additionally, corresponding to the used baudrate. The duty cycle can be adjusted using the BITCON.SAMPLEPOINT bitfield with the finest granularity of $T_{MAX} = 1 / f_{MAX}$.

2) Positive deviation lengthens the high time and shortens the low time of a clock period. Negative deviation does the opposite.

Electrical Specification ASCLIN SPI Master Timing

Table 3-52 Master Mode MPsm output pads

Parameter	Symbol	Values			Unit	Note / Test Condition
		Min.	Typ.	Max.		
ASCLKO clock period ¹⁾	t_{50} CC	200	-	-	ns	$C_L=50\text{pF}$
Deviation from ideal duty cycle ²⁾	t_{500} CC	-5	-	$9+0.06 * C_L$	ns	$0 < C_L < 200\text{pF}$
MTSR delay from ASCLKO shifting edge	t_{51} CC	-19	-	17	ns	$C_L=50\text{pF}$
ASLSON delay from the first ASCLKO edge	t_{510} CC	-19	-	17	ns	$C_L=50\text{pF}$
MRST setup to ASCLKO latching edge	t_{52} SR	100	-	-	ns	$C_L=50\text{pF}$
MRST hold from ASCLKO latching edge	t_{53} SR	-13	-	-	ns	$C_L=50\text{pF}$

- 1) PLL Jitter not included. Should be considered additionally, corresponding to the used baudrate. The duty cycle can be adjusted using the BITCON.SAMPLEPOINT bitfield with the finest granularity of $T_{MAX} = 1 / f_{MAX}$.
- 2) Positive deviation lengthens the high time and shortens the low time of a clock period. Negative deviation does the opposite.

Table 3-53 Master Mode medium output pads

Parameter	Symbol	Values			Unit	Note / Test Condition
		Min.	Typ.	Max.		
ASCLKO clock period ¹⁾	t_{50} CC	400	-	-	ns	$C_L=50\text{pF}$
Deviation from ideal duty cycle ²⁾	t_{500} CC	$-6-0.07 * C_L$	-	$6+0.07 * C_L$	ns	$0 < C_L < 200\text{pF}$
MTSR delay from ASCLKO shifting edge	t_{51} CC	-33	-	25	ns	$C_L=50\text{pF}$
ASLSON delay from the first ASCLKO edge	t_{510} CC	-35	-	35	ns	$C_L=50\text{pF}$
MRST setup to ASCLKO latching edge	t_{52} SR	120	-	-	ns	$C_L=50\text{pF}$
MRST hold from ASCLKO latching edge	t_{53} SR	-13	-	-	ns	$C_L=50\text{pF}$

- 1) PLL Jitter not included. Should be considered additionally, corresponding to the used baudrate. The duty cycle can be adjusted using the BITCON.SAMPLEPOINT bitfield with the finest granularity of $T_{MAX} = 1 / f_{MAX}$.
- 2) Positive deviation lengthens the high time and shortens the low time of a clock period. Negative deviation does the opposite.

Table 3-54 Master Mode weak output pads

Parameter	Symbol	Values			Unit	Note / Test Condition
		Min.	Typ.	Max.		
ASCLKO clock period ¹⁾	t_{50} CC	2000	-	-	ns	$C_L=50\text{pF}$
Deviation from ideal duty cycle ²⁾	t_{500} CC	-110	-	150	ns	$0 < C_L < 200\text{pF}$

Electrical Specification ASCLIN SPI Master Timing

Table 3-54 Master Mode weak output pads (cont'd)

Parameter	Symbol	Values			Unit	Note / Test Condition
		Min.	Typ.	Max.		
MTSR delay from ASCLKO shifting edge	t_{51} CC	-170	-	170	ns	$C_L=50\text{pF}$
ASLSON delay from the first ASCLKO edge	t_{510} CC	-170	-	170	ns	$C_L=50\text{pF}$
MRST setup to ASCLKO latching edge	t_{52} SR	510	-	-	ns	$C_L=50\text{pF}$
MRST hold from ASCLKO latching edge	t_{53} SR	-40	-	-	ns	$C_L=50\text{pF}$

- 1) PLL Jitter not included. Should be considered additionally, corresponding to the used baudrate. The duty cycle can be adjusted using the BITCON.SAMPLEPOINT bitfield with the finest granularity of $T_{MAX} = 1 / f_{MAX}$.
- 2) Positive deviation lengthens the high time and shortens the low time of a clock period. Negative deviation does the opposite.

Table 3-55 Master Mode A2ss output pads

Parameter	Symbol	Values			Unit	Note / Test Condition
		Min.	Typ.	Max.		
ASCLKO clock period ¹⁾	t_{50} CC	20	-	-	ns	$C_L=50\text{pF}$
Deviation from ideal duty cycle ²⁾	t_{500} CC	-3	-	3	ns	$C_L=50\text{pF}$
MTSR delay from ASCLKO shifting edge	t_{51} CC	-4	-	4	ns	$C_L=50\text{pF}$
ASLSON delay from the first ASCLKO edge	t_{510} CC	-5	-	4	ns	$C_L=50\text{pF}$
MRST setup to ASCLKO latching edge	t_{52} SR	17	-	-	ns	$C_L=50\text{pF}$
MRST hold from ASCLKO latching edge	t_{53} SR	0	-	-	ns	$C_L=50\text{pF}$

- 1) PLL Jitter not included. Should be considered additionally, corresponding to the used baudrate. The duty cycle can be adjusted using the BITCON.SAMPLEPOINT bitfield with the finest granularity of $T_{MAX} = 1 / f_{MAX}$.
- 2) Positive deviation lengthens the high time and shortens the low time of a clock period. Negative deviation does the opposite.

Table 3-56 Master Mode A2sm output pads

Parameter	Symbol	Values			Unit	Note / Test Condition
		Min.	Typ.	Max.		
ASCLKO clock period ¹⁾	t_{50} CC	40	-	-	ns	$C_L=50\text{pF}$
Deviation from ideal duty cycle ²⁾	t_{500} CC	-4	-	4	ns	$C_L=50\text{pF}$
MTSR delay from ASCLKO shifting edge	t_{51} CC	-8	-	6	ns	$C_L=50\text{pF}$
ASLSON delay from the first ASCLKO edge	t_{510} CC	-8	-	9	ns	$C_L=50\text{pF}$

Electrical Specification ASCLIN SPI Master Timing

Table 3-56 Master Mode A2sm output pads (cont'd)

Parameter	Symbol	Values			Unit	Note / Test Condition
		Min.	Typ.	Max.		
MRST setup to ASCLKO latching edge	t_{52} SR	26	-	-	ns	$C_L=50\text{pF}$
MRST hold from ASCLKO latching edge	t_{53} SR	0	-	-	ns	$C_L=50\text{pF}$

- 1) PLL Jitter not included. Should be considered additionally, corresponding to the used baudrate. The duty cycle can be adjusted using the BITCON.SAMPLEPOINT bitfield with the finest granularity of $T_{MAX} = 1 / f_{MAX}$.
- 2) Positive deviation lengthens the high time and shortens the low time of a clock period. Negative deviation does the opposite.

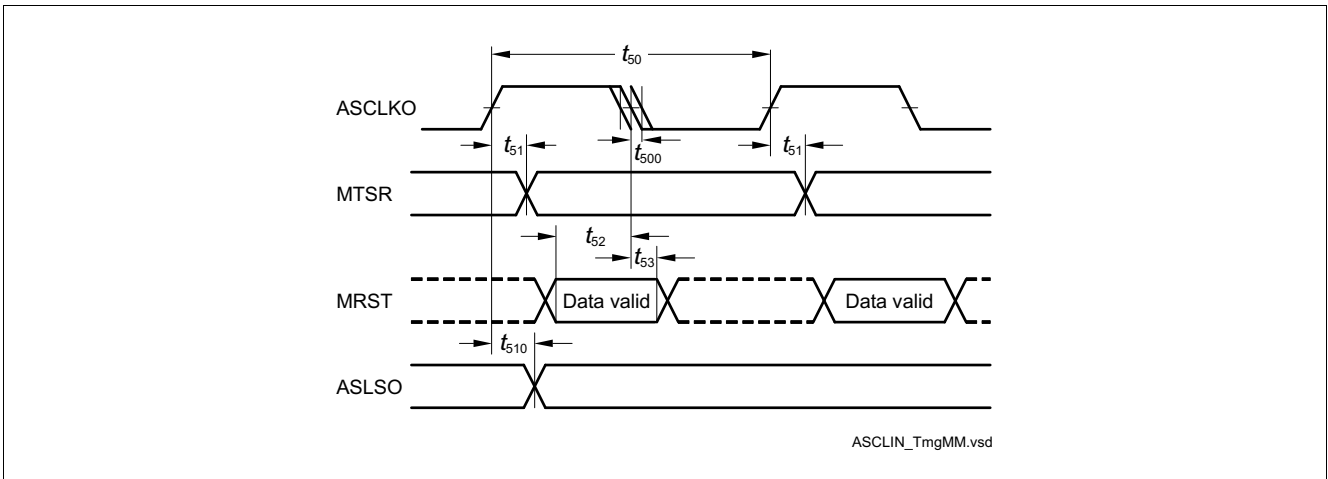

Figure 3-17 ASCLIN SPI Master Timing

3.25 QSPI Timings, Master and Slave Mode

This section defines the timings for the QSPI in the TC 260 / 264 / 265 / 267, for 5V pad power supply. It is assumed that SCLKO, MTSR, and SLSO pads have the same pad settings:

- LVDSM output pads, LVDSH input pad, master mode, $C_L=25\text{pF}$
- Medium Performance Plus Pads (MP+):
 - strong sharp edge (MP+ss), $C_L=25\text{pF}$
 - strong medium edge (MP+sm), $C_L=50\text{pF}$
 - medium edge (MP+m), $C_L=50\text{pF}$
 - weak edge (MP+w), $C_L=50\text{pF}$
- Medium Performance Pads (MP):
 - strong sharp edge (MPss), $C_L=25\text{pF}$
 - strong medium edge (MPsm), $C_L=50\text{pF}$
- Medium and Low Performance Pads (MP/LP), the identical output strength settings:
 - medium edge (LP/MPm), $C_L=50\text{pF}$
 - weak edge (MPw), $C_L=50\text{pF}$

Note: Pad asymmetry is already included in the following timings.

Table 3-57 Master Mode Timing, LVDSM output pads for data and clock

Parameter	Symbol	Values			Unit	Note / Test Condition
		Min.	Typ.	Max.		
SCLKO clock period ¹⁾	t_{50} CC	20 ²⁾	-	-	ns	$C_L=25\text{pF}$
Deviation from the ideal duty cycle ^{3) 4)}	t_{500} CC	-1	-	1	ns	$C_L=25\text{pF}$
MTSR delay from SCLKO shifting edge	t_{51} CC	-3	-	3	ns	$C_L=25\text{pF}$
SLSO deviation from the ideal programmed position	t_{510} CC	0	-	30	ns	$C_L=25\text{pF}$; MPsm
		-5	-	7	ns	$C_L=25\text{pF}$; MPss
		-4	-	7	ns	MP+ss; $C_L=25\text{pF}$
		-1	-	15	ns	MP+sm; $C_L=25\text{pF}$
MRST setup to SCLK latching edge ⁵⁾	t_{52} SR	19 ⁵⁾	-	-	ns	$C_L=25\text{pF}$; LVDSM 5V output and LVDSH 3.3V input
MRST hold from SCLK latching edge	t_{53} SR	-6 ⁵⁾	-	-	ns	$C_L=25\text{pF}$; LVDSM 5V output and LVDSH 3.3V input

- 1) Documented value is valid for master transmit or slave receive only. For full duplex the external SPI counterpart timing has to be taken into account.
- 2) The capacitive load on the LVDS pins is differential, the capacitive load on the CMOS pins is single ended.
- 3) The PLL jitter is not included. It should be considered additionally, corresponding to the used baudrate. The duty cycle can be adjusted using the bit fields ECONz.A, B and C with the finest granularity of $T_{MAX} = 1 / f_{MAX}$.
- 4) Positive deviation lengthens the high time and shortens the low time of a clock period. Negative deviation does the opposite.
- 5) For compensation of the average on-chip delay the QSPI module provides the bit fields ECONz.A, B and C.

Electrical Specification QSPI Timings, Master and Slave Mode

Table 3-58 Master Mode MP+ss/MPRss output pads

Parameter	Symbol	Values			Unit	Note / Test Condition
		Min.	Typ.	Max.		
SCLKO clock period ¹⁾	t_{50} CC	20	-	-	ns	$C_L=25\text{pF}$
Deviation from the ideal duty cycle ^{2) 3)}	t_{500} CC	-3	-	3	ns	$0 < C_L < 50\text{pF}$
MISR delay from SCLKO shifting edge	t_{51} CC	-7	-	6	ns	$C_L=25\text{pF}$
SLSON deviation from the ideal programmed position	t_{510} CC	-7	-	6	ns	$C_L=25\text{pF}$
MRST setup to SCLK latching edge ⁴⁾	t_{52} SR	27 ⁴⁾⁵⁾	-	-	ns	$C_L=25\text{pF}$
MRST hold from SCLK latching edge	t_{53} SR	-6 ⁴⁾⁵⁾	-	-	ns	$C_L=25\text{pF}$

- 1) Documented value is valid for master transmit or slave receive only. For full duplex the external SPI counterpart timing has to be taken into account.
- 2) The PLL jitter is not included. It should be considered additionally, corresponding to the used baudrate. The duty cycle can be adjusted using the bit fields ECONz.A, B and C with the finest granularity of $T_{MAX} = 1 / f_{MAX}$.
- 3) Positive deviation lengthens the high time and shortens the low time of a clock period. Negative deviation does the opposite.
- 4) For compensation of the average on-chip delay the QSPI module provides the bit fields ECONz.A, B and C.
- 5) The setup and hold times are valid for both settings of the input pads thresholds: TTL and AL.

Table 3-59 Master Mode MP+sm/MPRsm output pads for data and clock

Parameter	Symbol	Values			Unit	Note / Test Condition
		Min.	Typ.	Max.		
SCLKO clock period ¹⁾	t_{50} CC	50	-	-	ns	$C_L=50\text{pF}$
Deviation from the ideal duty cycle ^{2) 3)}	t_{500} CC	-2	-	$3+0.01 * C_L$	ns	$0 < C_L < 200\text{pF}$
MISR delay from SCLKO shifting edge	t_{51} CC	-10	-	10	ns	$C_L=50\text{pF}$
SLSON deviation from the ideal programmed position	t_{510} CC	-10	-	10	ns	MP+sm; $C_L=50\text{pF}$
		-13	-	1	ns	MPss; $C_L=50\text{pF}$
		0	-	40	ns	MP+m, MPm, LPM; $C_L=50\text{pF}$
MRST setup to SCLK latching edge ⁴⁾	t_{52} SR	50 ⁴⁾⁵⁾	-	-	ns	$C_L=50\text{pF}$
MRST hold from SCLK latching edge	t_{53} SR	-10 ⁴⁾⁵⁾	-	-	ns	$C_L=50\text{pF}$

- 1) Documented value is valid for master transmit or slave receive only. For full duplex the external SPI counterpart timing has to be taken into account.
- 2) The PLL jitter is not included. It should be considered additionally, corresponding to the used baudrate. The duty cycle can be adjusted using the bit fields ECONz.A, B and C with the finest granularity of $T_{MAX} = 1 / f_{MAX}$.
- 3) Positive deviation lengthens the high time and shortens the low time of a clock period. Negative deviation does the opposite.

Electrical Specification QSPI Timings, Master and Slave Mode

- 4) For compensation of the average on-chip delay the QSPI module provides the bit fields ECONz.A, B and C.
 5) The setup and hold times are valid for both settings of the input pads thresholds: TTL and AL.

Table 3-60 Master Mode timing MPss output pads for data and clock, $C_L=50\text{pF}$

Parameter	Symbol	Values			Unit	Note / Test Condition
		Min.	Typ.	Max.		
SCLKO clock period ¹⁾	t_{50} CC	40	-	-	ns	$C_L=50\text{pF}$
Deviation from the ideal duty cycle ^{2) 3)}	t_{500} CC	-2	-	$3.5+0.035 * C_L$	ns	$0 < C_L < 200\text{pF}$
MTSR delay from SCLKO shifting edge	t_{51} CC	-8	-	8	ns	$C_L=50\text{pF}$
SLSON deviation from the ideal programmed position	t_{510} CC	-8	-	8	ns	MPss; $C_L=50\text{pF}$
		-1	-	15	ns	MP+sm; $C_L=50\text{pF}$
		0	-	50	ns	MP+m, MPm, LPM; $C_L=50\text{pF}$
MRST setup to SCLK latching edge ⁴⁾	t_{52} SR	$40^{4)5)}$	-	-	ns	$C_L=50\text{pF}$
MRST hold from SCLK latching edge	t_{53} SR	$-5^{4)5)}$	-	-	ns	$C_L=50\text{pF}$

- 1) Documented value is valid for master transmit or slave receive only. For full duplex the external SPI counterpart timing has to be taken into account.
 2) The PLL jitter is not included. It should be considered additionally, corresponding to the used baudrate. The duty cycle can be adjusted using the bit fields ECONz.A, B and C with the finest granularity of $T_{MAX} = 1 / f_{MAX}$.
 3) Positive deviation lengthens the high time and shortens the low time of a clock period. Negative deviation does the opposite.
 4) For compensation of the average on-chip delay the QSPI module provides the bit fields ECONz.A, B and C.
 5) The setup and hold times are valid for both settings of the input pads thresholds: TTL and AL.

Table 3-61 Master Mode timing MPsm output pads

Parameter	Symbol	Values			Unit	Note / Test Condition
		Min.	Typ.	Max.		
SCLKO clock period ¹⁾	t_{50} CC	100	-	-	ns	$C_L=50\text{pF}$
Deviation from the ideal duty cycle ^{2) 3)}	t_{500} CC	-3	-	$4+0.04 * C_L$	ns	$0 < C_L < 200\text{pF}$
MTSR delay from SCLKO shifting edge	t_{51} CC	-11	-	10	ns	$C_L=50\text{pF}$
SLSON deviation from the ideal programmed position	t_{510} CC	-11	-	10	ns	$C_L=50\text{pF}$
MRST setup to SCLK latching edge ⁴⁾	t_{52} SR	$60^{4)5)}$	-	-	ns	$C_L=50\text{pF}$
MRST hold from SCLK latching edge	t_{53} SR	$-10^{4)5)}$	-	-	ns	$C_L=50\text{pF}$

- 1) Documented value is valid for master transmit or slave receive only. For full duplex the external SPI counterpart timing has to be taken into account.

Electrical Specification QSPI Timings, Master and Slave Mode

- 2) The PLL jitter is not included. It should be considered additionally, corresponding to the used baudrate. The duty cycle can be adjusted using the bit fields ECONz.A, B and C with the finest granularity of $T_{MAX} = 1 / f_{MAX}$.
- 3) Positive deviation lengthens the high time and shortens the low time of a clock period. Negative deviation does the opposite.
- 4) For compensation of the average on-chip delay the QSPI module provides the bit fields ECONz.A, B and C.
- 5) The setup and hold times are valid for both settings of the input pads thresholds: TTL and AL.

Table 3-62 Master Mode timing MPRm/MP+m/MPm/LPm output pads

Parameter	Symbol	Values			Unit	Note / Test Condition
		Min.	Typ.	Max.		
SCLKO clock period ¹⁾	t_{50} CC	200	-	-	ns	$C_L=50\text{pF}$
Deviation from the ideal duty cycle ^{2) 3)}	t_{500} CC	-10	-	$4+0.04 * C_L$	ns	$0 < C_L < 200\text{pF}$
MTSR delay from SCLKO shifting edge	t_{51} CC	-15	-	17	ns	$C_L=50\text{pF}$
SLSON deviation from the ideal programmed position	t_{510} CC	-20	-	20	ns	$C_L=50\text{pF}$
MRST setup to SCLK latching edge ⁴⁾	t_{52} SR	$70^{4)5)}$	-	-	ns	$C_L=50\text{pF}$
MRST hold from SCLK latching edge	t_{53} SR	$-10^{4)5)}$	-	-	ns	$C_L=50\text{pF}$

- 1) Documented value is valid for master transmit or slave receive only. For full duplex the external SPI counterpart timing has to be taken into account.
- 2) The PLL jitter is not included. It should be considered additionally, corresponding to the used baudrate. The duty cycle can be adjusted using the bit fields ECONz.A, B and C with the finest granularity of $T_{MAX} = 1 / f_{MAX}$.
- 3) Positive deviation lengthens the high time and shortens the low time of a clock period. Negative deviation does the opposite.
- 4) For compensation of the average on-chip delay the QSPI module provides the bit fields ECONz.A, B and C.
- 5) The setup and hold times are valid for both settings of the input pads thresholds: TTL and AL.

Table 3-63 Master Mode Weak output pads

Parameter	Symbol	Values			Unit	Note / Test Condition
		Min.	Typ.	Max.		
SCLKO clock period ¹⁾	t_{50} CC	1000	-	-	ns	$C_L=50\text{pF}$
Deviation from the ideal duty cycle ^{2) 3)}	t_{500} CC	-30	-	$30+0.15 * C_L$	ns	$0 < C_L < 200\text{pF}$
MTSR delay from SCLKO shifting edge	t_{51} CC	-65	-	65	ns	$C_L=50\text{pF}$
SLSON deviation from the ideal programmed position	t_{510} CC	-65	-	65	ns	$C_L=50\text{pF}$
MRST setup to SCLK latching edge ⁴⁾	t_{52} SR	$300^{4)5)}$	-	-	ns	$C_L=50\text{pF}$
MRST hold from SCLK latching edge	t_{53} SR	$-40^{4)5)}$	-	-	ns	$C_L=50\text{pF}$

- 1) Documented value is valid for master transmit or slave receive only. For full duplex the external SPI counterpart timing has to be taken into account.

Electrical Specification QSPI Timings, Master and Slave Mode

- 2) The PLL jitter is not included. It should be considered additionally, corresponding to the used baudrate. The duty cycle can be adjusted using the bit fields ECONz.A, B and C with the finest granularity of $T_{MAX} = 1 / f_{MAX}$.
- 3) Positive deviation lengthens the high time and shortens the low time of a clock period. Negative deviation does the opposite.
- 4) For compensation of the average on-chip delay the QSPI module provides the bit fields ECONz.A, B and C.
- 5) The setup and hold times are valid for both settings of the input pads thresholds: TTL and AL.

Table 3-64 Slave mode timing

Parameter	Symbol	Values			Unit	Note / Test Condition
		Min.	Typ.	Max.		
SCLK clock period	t_{54} SR	$4 \times T_{MAX}$	-	-	ns	
SCLK duty cycle	$t_{55/t54}$ SR	40	-	60	%	
MISR setup to SCLK latching edge	t_{56} SR	4	-	-	ns	Hystheresis Inactive
		5	-	-	ns	Input Level AL
		5	-	-	ns	Input Level TTL
MISR hold from SCLK latching edge	t_{57} SR	3	-	-	ns	Hystheresis Inactive
		6	-	-	ns	Input Level AL
		9	-	-	ns	Input Level TTL
SLSI setup to first SCLK shift edge	t_{58} SR	5 ¹⁾	-	-	ns	Hystheresis Inactive
		4 ¹⁾	-	-	ns	Input Level AL
		8	-	-	ns	Input Level TTL
		6	-	-	ns	Only for pin 15.1, AL
SLSI hold from last SCLK latching edge	t_{59} SR	3	-	-	ns	Hystheresis Inactive
		4	-	-	ns	Input Level AL
		8	-	-	ns	Input Level TTL
MRST delay from SCLK shift edge	t_{60} CC	10	-	70	ns	MP+m/MPRm; $C_L=50pF$
		10	-	50	ns	MP+sm/MPRsm; $C_L=50pF$
		5	-	30	ns	MP+ss/MPRss; $C_L=25pF$
		40	-	300	ns	MP+w/MPRw; $C_L=50pF$
		10	-	70	ns	MPm/LPm; $C_L=50pF$
		10	-	55	ns	MPsm; $C_L=50pF$
		5	-	30	ns	MPss; $C_L=25pF$
		40	-	300	ns	MPw/LPw; $C_L=50pF$
SLSI to valid data on MRST	t_{61} SR	-	-	5	ns	

1) Except pin P15.1.

Electrical Specification QSPI Timings, Master and Slave Mode

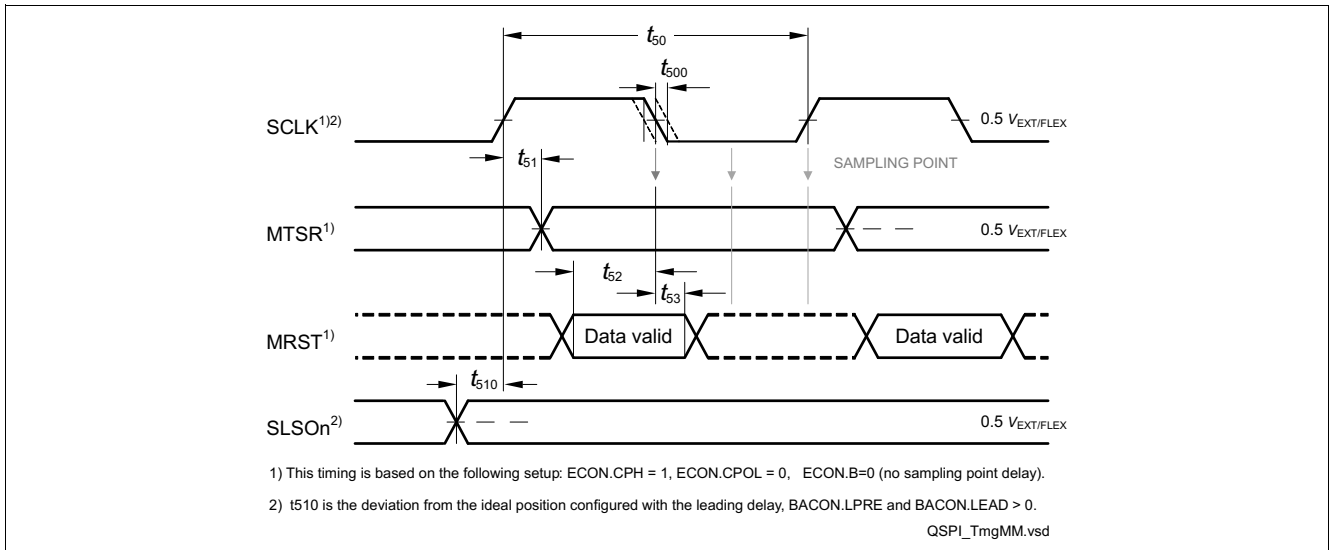

Figure 3-18 Master Mode Timing

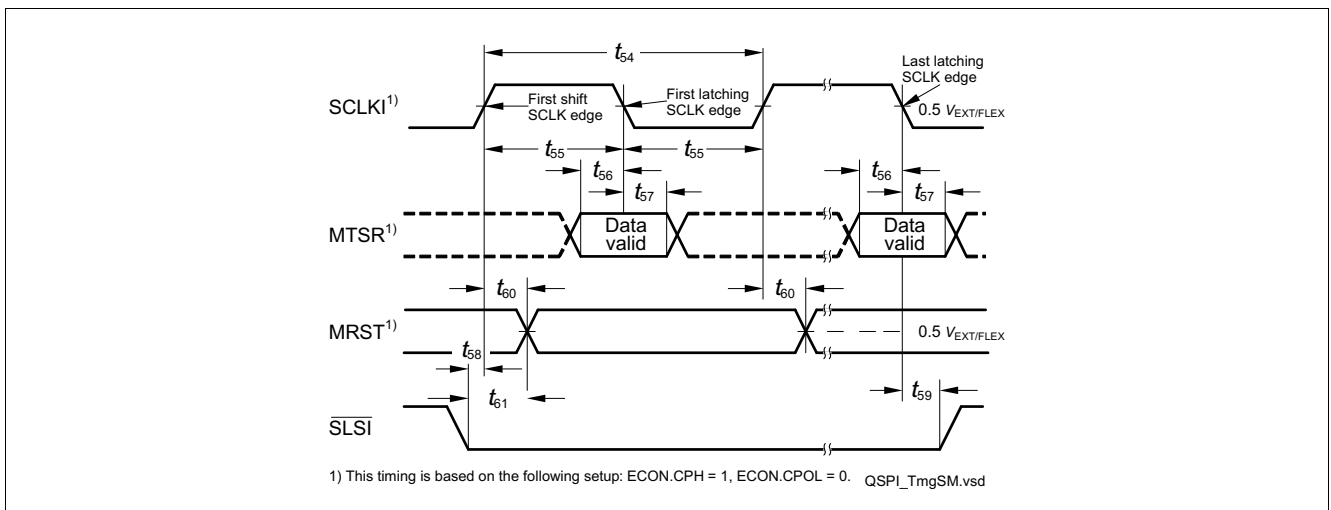

Figure 3-19 Slave Mode Timing

3.26 QSPI Timings, Master and Slave Mode

This section defines the timings for the QSPI in the TC 260 / 264 / 265 / 267, for 3.3V pad power supply. It is assumed that SCLKO, MTSR, and SLSO pads have the same pad settings:

- LVDSM output pads, LVDSH input pad, master mode, $C_L=25\text{pF}$
- Medium Performance Plus Pads (MP+):
 - strong sharp edge (MP+ss), $C_L=25\text{pF}$
 - strong medium edge (MP+sm), $C_L=50\text{pF}$
 - medium edge (MP+m), $C_L=50\text{pF}$
 - weak edge (MP+w), $C_L=50\text{pF}$
- Medium Performance Pads (MP):
 - strong sharp edge (MPss), $C_L=25\text{pF}$
 - strong medium edge (MPsm), $C_L=50\text{pF}$
- Medium and Low Performance Pads (MP/LP), the identical output strength settings:
 - medium edge (LP/MPm), $C_L=50\text{pF}$
 - weak edge (MPw), $C_L=50\text{pF}$

Note: Pad asymmetry is already included in the following timings.

Table 3-65 Master Mode Timing, LVDSM output pads for data and clock

Parameter	Symbol	Values			Unit	Note / Test Condition
		Min.	Typ.	Max.		
SCLKO clock period ¹⁾	t_{50} CC	20	-	-	ns	$C_L=25\text{pF}$
Deviation from the ideal duty cycle ^{2) 3)}	t_{500} CC	-2	-	2	ns	$C_L=25\text{pF}$
MTSR delay from SCLKO shifting edge	t_{51} CC	-5	-	5	ns	$C_L=25\text{pF}$
SLSO deviation from the ideal programmed position	t_{510} CC	-2	-	55	ns	$C_L=25\text{pF}$; MPsm
		-9	-	12	ns	$C_L=25\text{pF}$; MPss
		-7	-	12	ns	MP+ss; $C_L=25\text{pF}$
		-2	-	26	ns	MP+sm; $C_L=25\text{pF}$
MRST setup to SCLK latching edge ⁴⁾	t_{52} SR	20	-	-	ns	$C_L=25\text{pF}$; LVDSM 5V output and LVDSH 3.3V input
MRST hold from SCLK latching edge	t_{53} SR	-6	-	-	ns	$C_L=25\text{pF}$; LVDSM 5V output and LVDSH 3.3V input

1) Documented value is valid for master transmit or slave receive only. For full duplex the external SPI counterpart timing has to be taken into account.

2) The PLL jitter is not included. It should be considered additionally, corresponding to the used baudrate. The duty cycle can be adjusted using the bit fields ECONZ.A, B and C with the finest granularity of $T_{MAX} = 1 / f_{MAX}$.

3) Positive deviation lengthens the high time and shortens the low time of a clock period. Negative deviation does the opposite.

4) For compensation of the average on-chip delay the QSPI module provides the bit fields ECONZ.A, B and C.

Electrical Specification QSPI Timings, Master and Slave Mode

Table 3-66 Master Mode MP+ss/MPRss output pads

Parameter	Symbol	Values			Unit	Note / Test Condition
		Min.	Typ.	Max.		
SCLKO clock period ¹⁾	t_{50} CC	40	-	-	ns	$C_L=25\text{pF}$
Deviation from the ideal duty cycle ^{2) 3)}	t_{500} CC	-5	-	5	ns	$0 < C_L < 50\text{pF}$
MISR delay from SCLKO shifting edge	t_{51} CC	-12	-	12	ns	$C_L=25\text{pF}$
SLSON deviation from the ideal programmed position	t_{510} CC	-12	-	12	ns	$C_L=25\text{pF}$
MRST setup to SCLK latching edge ⁴⁾	t_{52} SR	50 ⁴⁾⁵⁾	-	-	ns	$C_L=25\text{pF}$
MRST hold from SCLK latching edge	t_{53} SR	-6 ⁴⁾⁵⁾	-	-	ns	$C_L=25\text{pF}$

- 1) Documented value is valid for master transmit or slave receive only. For full duplex the external SPI counterpart timing has to be taken into account.
- 2) The PLL jitter is not included. It should be considered additionally, corresponding to the used baudrate. The duty cycle can be adjusted using the bit fields ECONz.A, B and C with the finest granularity of $T_{MAX} = 1 / f_{MAX}$.
- 3) Positive deviation lengthens the high time and shortens the low time of a clock period. Negative deviation does the opposite.
- 4) For compensation of the average on-chip delay the QSPI module provides the bit fields ECONz.A, B and C.
- 5) The setup and hold times are valid for both settings of the input pads thresholds: TTL and AL.

Table 3-67 Master Mode MP+sm/MPRsm output pads for data and clock

Parameter	Symbol	Values			Unit	Note / Test Condition
		Min.	Typ.	Max.		
SCLKO clock period ¹⁾	t_{50} CC	100	-	-	ns	$C_L=50\text{pF}$
Deviation from the ideal duty cycle ^{2) 3)}	t_{500} CC	-3	-	7	ns	$0 < C_L < 200\text{pF}$
MISR delay from SCLKO shifting edge	t_{51} CC	-17	-	17	ns	$C_L=50\text{pF}$
SLSON deviation from the ideal programmed position	t_{510} CC	-17	-	17	ns	MP+sm; $C_L=50\text{pF}$
		-22	-	2	ns	MPss; $C_L=50\text{pF}$
		0	-	70	ns	MP+m; MPm; LPm; $C_L=50\text{pF}$
MRST setup to SCLK latching edge ⁴⁾	t_{52} SR	85 ⁴⁾⁵⁾	-	-	ns	$C_L=50\text{pF}$
MRST hold from SCLK latching edge	t_{53} SR	-10 ⁴⁾⁵⁾	-	-	ns	$C_L=50\text{pF}$

- 1) Documented value is valid for master transmit or slave receive only. For full duplex the external SPI counterpart timing has to be taken into account.
- 2) The PLL jitter is not included. It should be considered additionally, corresponding to the used baudrate. The duty cycle can be adjusted using the bit fields ECONz.A, B and C with the finest granularity of $T_{MAX} = 1 / f_{MAX}$.
- 3) Positive deviation lengthens the high time and shortens the low time of a clock period. Negative deviation does the opposite.

Electrical Specification QSPI Timings, Master and Slave Mode

- 4) For compensation of the average on-chip delay the QSPI module provides the bit fields ECONz.A, B and C.
- 5) The setup and hold times are valid for both settings of the input pads thresholds: TTL and AL.

Table 3-68 Master Mode timing MPss output pads

Parameter	Symbol	Values			Unit	Note / Test Condition
		Min.	Typ.	Max.		
SCLKO clock period ¹⁾	t_{50} CC	40	-	-	ns	$C_L=25\text{pF}$
Deviation from the ideal duty cycle ^{2) 3)}	t_{500} CC	-5	-	$7+0.07 \cdot C_L^*$	ns	$C_L=25\text{pF}$
MTSR delay from SCLKO shifting edge	t_{51} CC	-10	-	10	ns	$C_L=25\text{pF}$
SLSON deviation from the ideal programmed position	t_{510} CC	-10	-	10	ns	$C_L=25\text{pF}$
MRST setup to SCLK latching edge ⁴⁾	t_{52} SR	$50^{4)5)}$	-	-	ns	$C_L=25\text{pF}$
MRST hold from SCLK latching edge	t_{53} SR	$-6^{4)5)}$	-	-	ns	$C_L=25\text{pF}$

- 1) Documented value is valid for master transmit or slave receive only. For full duplex the external SPI counterpart timing has to be taken into account.
- 2) The PLL jitter is not included. It should be considered additionally, corresponding to the used baudrate. The duty cycle can be adjusted using the bit fields ECONz.A, B and C with the finest granularity of $T_{MAX} = 1 / f_{MAX}$.
- 3) Positive deviation lengthens the high time and shortens the low time of a clock period. Negative deviation does the opposite.
- 4) For compensation of the average on-chip delay the QSPI module provides the bit fields ECONz.A, B and C.
- 5) The setup and hold times are valid for both settings of the input pads thresholds: TTL and AL.

Table 3-69 Master Mode timing MPsm output pads

Parameter	Symbol	Values			Unit	Note / Test Condition
		Min.	Typ.	Max.		
SCLKO clock period ¹⁾	t_{50} CC	200	-	-	ns	$C_L=50\text{pF}$
Deviation from the ideal duty cycle ^{2) 3)}	t_{500} CC	-5	-	$9+0.06 \cdot C_L^*$	ns	$0 < C_L < 200\text{pF}$
MTSR delay from SCLKO shifting edge	t_{51} CC	-19	-	19	ns	$C_L=50\text{pF}$
SLSON deviation from the ideal programmed position	t_{510} CC	-19	-	17	ns	$C_L=50\text{pF}$
MRST setup to SCLK latching edge ⁴⁾	t_{52} SR	$100^{4)5)}$	-	-	ns	$C_L=50\text{pF}$
MRST hold from SCLK latching edge	t_{53} SR	$-13^{4)5)}$	-	-	ns	$C_L=50\text{pF}$

- 1) Documented value is valid for master transmit or slave receive only. For full duplex the external SPI counterpart timing has to be taken into account.
- 2) The PLL jitter is not included. It should be considered additionally, corresponding to the used baudrate. The duty cycle can be adjusted using the bit fields ECONz.A, B and C with the finest granularity of $T_{MAX} = 1 / f_{MAX}$.
- 3) Positive deviation lengthens the high time and shortens the low time of a clock period. Negative deviation does the opposite.

Electrical Specification QSPI Timings, Master and Slave Mode

- 4) For compensation of the average on-chip delay the QSPI module provides the bit fields ECONz.A, B and C.
- 5) The setup and hold times are valid for both settings of the input pads thresholds: TTL and AL.

Table 3-70 Master Mode timing MPRm/MP+m/MPm/LPm output pads

Parameter	Symbol	Values			Unit	Note / Test Condition
		Min.	Typ.	Max.		
SCLKO clock period ¹⁾	t_{50} CC	400	-	-	ns	$C_L=50\text{pF}$
Deviation from the ideal duty cycle ^{2) 3)}	t_{500} CC	-6-0.07 * C_L	-	6+0.07 * C_L	ns	$0 < C_L < 200\text{pF}$
MTSR delay from SCLKO shifting edge	t_{51} CC	-25	-	33	ns	$C_L=50\text{pF}$
SLSON deviation from the ideal programmed position	t_{510} CC	-35	-	35	ns	$C_L=50\text{pF}$
MRST setup to SCLK latching edge ⁴⁾	t_{52} SR	120 ⁴⁾⁵⁾	-	-	ns	$C_L=50\text{pF}$
MRST hold from SCLK latching edge	t_{53} SR	-13 ⁴⁾⁵⁾	-	-	ns	$C_L=50\text{pF}$

- 1) Documented value is valid for master transmit or slave receive only. For full duplex the external SPI counterpart timing has to be taken into account.
- 2) The PLL jitter is not included. It should be considered additionally, corresponding to the used baudrate. The duty cycle can be adjusted using the bit fields ECONz.A, B and C with the finest granularity of $T_{MAX} = 1 / f_{MAX}$.
- 3) Positive deviation lengthens the high time and shortens the low time of a clock period. Negative deviation does the opposite.
- 4) For compensation of the average on-chip delay the QSPI module provides the bit fields ECONz.A, B and C.
- 5) The setup and hold times are valid for both settings of the input pads thresholds: TTL and AL.

Table 3-71 Master Mode Weak output pads

Parameter	Symbol	Values			Unit	Note / Test Condition
		Min.	Typ.	Max.		
SCLKO clock period ¹⁾	t_{50} CC	2000	-	-	ns	$C_L=50\text{pF}$
Deviation from the ideal duty cycle ^{2) 3)}	t_{500} CC	-110	-	110	ns	$0 < C_L < 200\text{pF}$
MTSR delay from SCLKO shifting edge	t_{51} CC	-170	-	170	ns	$C_L=50\text{pF}$
SLSON deviation from the ideal programmed position	t_{510} CC	-170	-	170	ns	$C_L=50\text{pF}$
MRST setup to SCLK latching edge ⁴⁾	t_{52} SR	510 ⁴⁾⁵⁾	-	-	ns	$C_L=50\text{pF}$
MRST hold from SCLK latching edge	t_{53} SR	-40 ⁴⁾⁵⁾	-	-	ns	$C_L=50\text{pF}$

- 1) Documented value is valid for master transmit or slave receive only. For full duplex the external SPI counterpart timing has to be taken into account.
- 2) The PLL jitter is not included. It should be considered additionally, corresponding to the used baudrate. The duty cycle can be adjusted using the bit fields ECONz.A, B and C with the finest granularity of $T_{MAX} = 1 / f_{MAX}$.
- 3) Positive deviation lengthens the high time and shortens the low time of a clock period. Negative deviation does the opposite.

Electrical Specification QSPI Timings, Master and Slave Mode

- 4) For compensation of the average on-chip delay the QSPI module provides the bit fields ECONz.A, B and C.
 5) The setup and hold times are valid for both settings of the input pads thresholds: TTL and AL.

Table 3-72 Slave mode timing

Parameter	Symbol	Values			Unit	Note / Test Condition
		Min.	Typ.	Max.		
SCLK clock period	t_{54} SR	$4 \times T_{MAX}$	-	-	ns	
SCLK duty cycle	$t_{55/t54}$ SR	40	-	60	%	
MISR setup to SCLK latching edge	t_{56} SR	7	-	-	ns	Hystheresis inactive
		9	-	-	ns	Input Level AL
		7	-	-	ns	Input Level TTL
MISR hold from SCLK latching edge	t_{57} SR	5	-	-	ns	Hystheresis inactive
		11	-	-	ns	Input Level AL
		16	-	-	ns	Input Level TTL
SLSI setup to first SCLK shift edge	t_{58} SR	7 ¹⁾	-	-	ns	Hystheresis inactive
		7 ¹⁾	-	-	ns	Input Level AL
		14	-	-	ns	Input Level TTL
		11	-	-	ns	Only for pin P15.1, AL
SLSI hold from last SCLK latching edge	t_{59} SR	5	-	-	ns	Hystheresis inactive
		7	-	-	ns	Input Level AL
		14	-	-	ns	Input Level TTL
MRST delay from SCLK shift edge	t_{60} CC	13	-	120	ns	MP+m/MPRm; $C_L=50pF$
		13	-	85	ns	MP+sm/MPRsm; $C_L=50pF$
		6	-	50	ns	MP+ss/MPRss; $C_L=25pF$
		70	-	500	ns	MP+w/MPRw; $C_L=50pF$
		13	-	120	ns	MPm/LPm; $C_L=50pF$
		13	-	100	ns	MPsm; $C_L=50pF$
		6	-	52	ns	MPss; $C_L=25pF$
70	-	500	ns	MPw/LPw; $C_L=50pF$		
SLSI to valid data on MRST	t_{61} SR	-	-	9	ns	

1) Except pin P15.1

Electrical Specification QSPI Timings, Master and Slave Mode

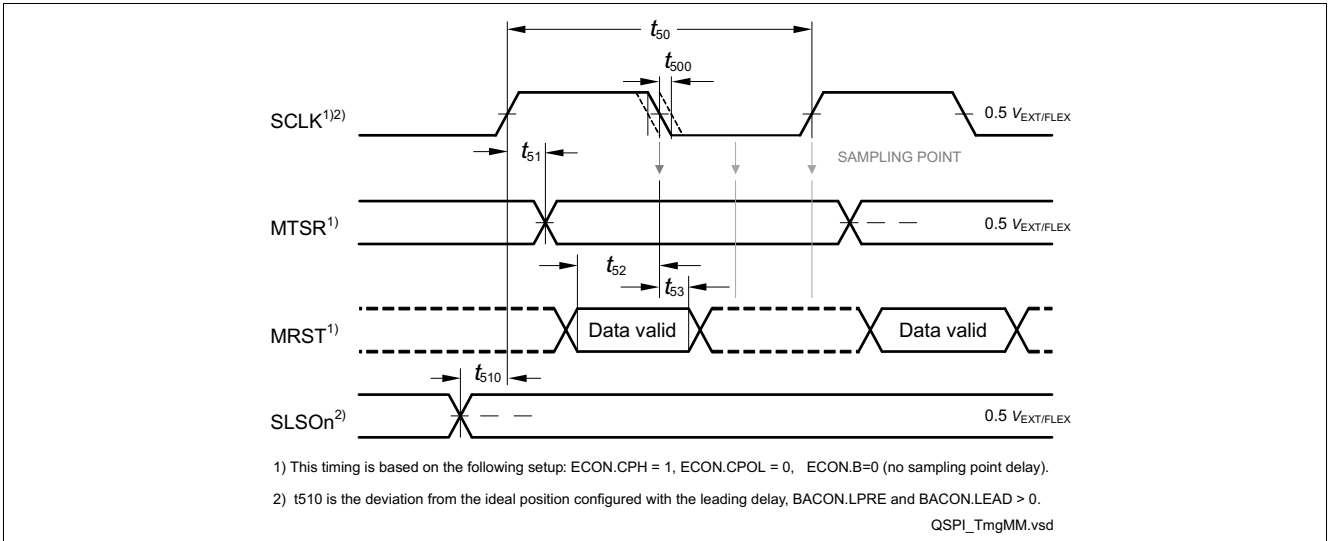

Figure 3-20 Master Mode Timing

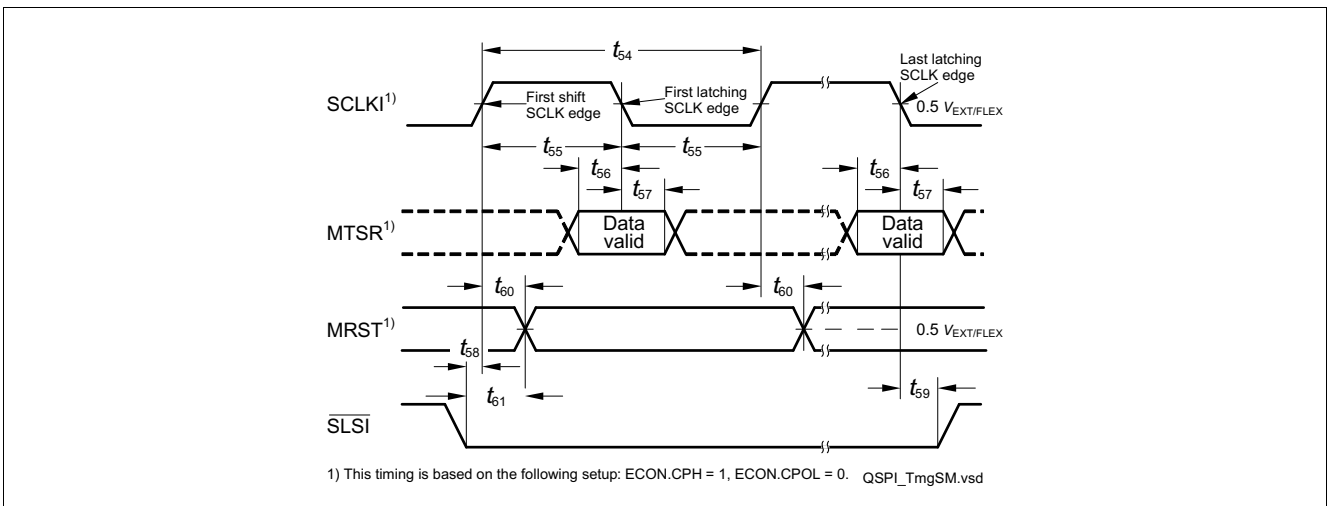

Figure 3-21 Slave Mode Timing

3.27 MSC Timing 5 V Operation

The following section defines the timings for 5V pad power supply.

Note: Pad asymmetry is already included in the following timings.

Note: Load for LVDS pads are defined as differential loads in the following timings.

Table 3-73 LVDS clock/data (LVDS pads in LVDS mode)

Parameter	Symbol	Values			Unit	Note / Test Condition
		Min.	Typ.	Max.		
FCLPx clock period ¹⁾	t_{40} CC	$2 * T_A$ ^{2) 3)}	-	-	ns	LVDSM; $C_L=50\text{pF}$
Deviation from ideal duty cycle ^{4) 5)}	t_{400} CC	-1	-	1	ns	LVDSM; $0 < C_L < 50\text{pF}$
SOPx output delay ⁶⁾	t_{44} CC	-3	-	4	ns	LVDSM; $C_L=50\text{pF}$; option EN01
		-4	-	4.5	ns	LVDSM; $C_L=50\text{pF}$; option EN01D
ENx output delay ⁶⁾	t_{45} CC	-4	-	5	ns	MP+ss/MPRss; option EN01; $C_L=25\text{pF}$
		-3	-	7	ns	MP+ss/MPRss; option EN01; $C_L=50\text{pF}$
		-3	-	11	ns	MP+sm/MPRsm; option EN01D; $C_L=50\text{pF}$
		-2	-	9	ns	MP+ss/MPRss; option EN23; $C_L=25\text{pF}$
		-2	-	10	ns	MP+ss/MPRss; option EN23; $C_L=50\text{pF}$
		-3	-	11	ns	MPss; option EN01; $C_L=50\text{pF}$
		-7	-	2	ns	MP+ss/MPRss; option EN01; $C_L=0\text{pF}$
		-5	-	3	ns	MP+sm/MPRsm; option EN01D; $C_L=0\text{pF}$
		-4	-	5	ns	MP+ss/MPRss; option EN23; $C_L=0\text{pF}$
		-7	-	4	ns	MPss; option EN01; $C_L=0\text{pF}$
SDI bit time	t_{46} CC	$8 * t_{\text{MSC}}$	-	-	ns	Upstream Timing
SDI rise time ⁷⁾	t_{48} SR	-	-	200	ns	Upstream Timing
SDI fall time ⁷⁾	t_{49} SR	-	-	200	ns	Upstream Timing

1) FCLP signal rise/fall times are the rise/fall times of the LVDSM pads, and the high/low times are $\min 1 * T_A$.

2) T_A depends on the clock source selected for baud rate generation in the ABRA block of the MSC.

3) The capacitive load on the LVDS pins is differential, the capacitive load on the CMOS pins is single ended.

Electrical Specification MSC Timing 5 V Operation

- 4) The PLL jitter is not included. It should be considered additionally, corresponding to the used baudrate. The duty cycle can be adjusted if the ABRA block is used.
- 5) Positive deviation lengthens the high time and shortens the low time of a clock period. Negative deviation does the opposite.
- 6) From FCLP rising edge.
- 7) When using slow and asymmetrical edges, like in case of open drain upstream connection, the application must take care that the bit is long enough (the baud rate is low enough) so that under worst case conditions the three sampling points in the middle of the bit are not violated.

Timing Options for t_{45}

The wiring shown in the [Figure 3-22](#) provides three useful timing options for t_{45} , depending on the signals selected with the alternate output lines (ALT1 to ALT7) in the ports:

- EN01 - FCLN, SON, EN0, EN1 - t_{45} reference timing
- EN01D - FCLND, SOND, EN0, EN1 - t_{45} window shifted to the left
- EN23 - FCLN, SON, EN2, EN3 - t_{45} window shifted to the right

The timings corresponding to EN01, EN01D, and EN23 are defined in the LVDS mode. In order to use the EN23 timings, the application should use the EN2 and EN3 outputs of the MSC module.

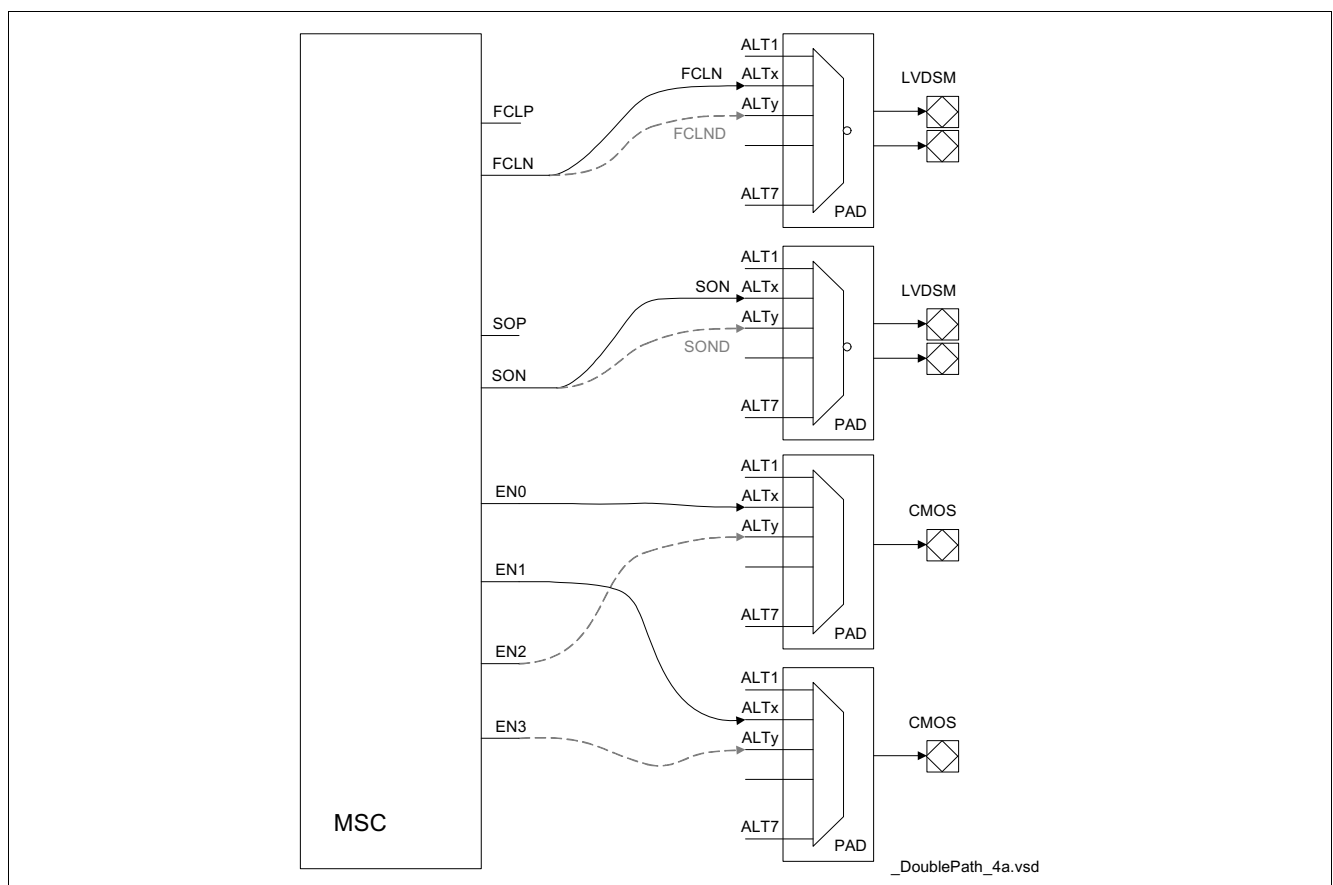

Figure 3-22 Timing Options for t_{45}

Table 3-74 MPss clock/data (LVDS pads in CMOS mode, option EN01)

Parameter	Symbol	Values			Unit	Note / Test Condition
		Min.	Typ.	Max.		
FCLPx clock period ¹⁾	t_{40} CC	$2 * T_A$ ^{2) 3)}	-	-	ns	MPss; $C_L=50\text{pF}$
Deviation from ideal duty cycle ^{4) 5)}	t_{400} CC	-2	-	$3+0.035 * C_L$	ns	MPss; $0 < C_L < 100\text{pF}$
SOPx output delay ⁶⁾	t_{44} CC	-4	-	7	ns	MPss; $C_L=50\text{pF}$

Electrical Specification MSC Timing 5 V Operation

Table 3-74 MPss clock/data (LVDS pads in CMOS mode, option EN01) (cont'd)

Parameter	Symbol	Values			Unit	Note / Test Condition
		Min.	Typ.	Max.		
ENx output delay ⁶⁾	t_{45} CC	-5	-	7	ns	MP+ss/MPRss; $C_L=50\text{pF}$
		-2	-	15	ns	MP+sm/MPRsm; $C_L=50\text{pF}$
		-4	-	10	ns	MPss; $C_L=50\text{pF}$
		0	-	30	ns	MPsm; $C_L=50\text{pF}$; except pin P13.0
		0	-	31	ns	MPsm; $C_L=50\text{pF}$; pin P13.0
		6	-	45	ns	MPm/MP+m/MPRm; $C_L=50\text{pF}$
		-11	-	2	ns	MP+ss/MPRss; $C_L=0\text{pF}$
		-4	-	7	ns	MP+sm/MPRsm; $C_L=0\text{pF}$
		-10	-	2	ns	MPss; $C_L=0\text{pF}$
		-1	-	16	ns	MPsm; $C_L=0\text{pF}$
		-2	-	18	ns	MP+m/MPm/MPRm; $C_L=0\text{pF}$
SDI bit time	t_{46} CC	$8 * t_{MSC}$	-	-	ns	Upstream Timing
SDI rise time ⁷⁾	t_{48} SR	-	-	200	ns	Upstream Timing
SDI fall time ⁷⁾	t_{49} SR	-	-	200	ns	Upstream Timing

- 1) FCLP signal rise/fall times are the rise/fall times of the LVDSM pads, and the high/low times are $\min 1 * T_A$.
- 2) T_A depends on the clock source selected for baud rate generation in the ABRA block of the MSC.
- 3) FCLP signal high and low can be minimum $1 * T_{MSC}$.
- 4) The PLL jitter is not included. It should be considered additionally, corresponding to the used baudrate. The duty cycle can be adjusted if the ABRA block is used.
- 5) Positive deviation lengthens the high time and shortens the low time of a clock period. Negative deviation does the opposite.
- 6) From FCLP rising edge.
- 7) When using slow and asymmetrical edges, like in case of open drain upstream connection, the application must take care that the bit is long enough (the baud rate is low enough) so that under worst case conditions the three sampling points in the middle of the bit are not violated.

Table 3-75 MP+sm/MPRsm clock/data

Parameter	Symbol	Values			Unit	Note / Test Condition
		Min.	Typ.	Max.		
FCLPx clock period ¹⁾	t_{40} CC	$2 * T_A$	-	-	ns	MP+sm/MPRsm; $C_L=50\text{pF}$
Deviation from ideal duty cycle ^{2) 3)}	t_{400} CC	-2	-	$3+0.01 * C_L$	ns	MP+sm/MPRsm; $0 < C_L < 200\text{pF}$
SOPx output delay ⁴⁾	t_{44} CC	-5	-	7	ns	MP+sm; $C_L=50\text{pF}$

Electrical Specification MSC Timing 5 V Operation

Table 3-75 MP+sm/MPRsm clock/data (cont'd)

Parameter	Symbol	Values			Unit	Note / Test Condition
		Min.	Typ.	Max.		
ENx output delay ⁴⁾	t_{45} CC	-13	-	2 ⁵⁾	ns	MPss; $C_L=50\text{pF}$
		-5	-	11	ns	MP+sm/MPRsm; $C_L=50\text{pF}$
		1	-	24	ns	MPsm; $C_L=50\text{pF}$
		4	-	37	ns	MP+m/MPm/MPRm; $C_L=50\text{pF}$
		-19	-	-1	ns	MPss; $C_L=0\text{pF}$
		-13	-	2	ns	MP+sm; $C_L=0\text{pF}$
		-5	-	8	ns	MPsm; $C_L=0\text{pF}$
		-5	-	10	ns	MPm/MP+m/MPRm; $C_L=0\text{pF}$

- 1) FCLP signal rise/fall times are the rise/fall times of the LVDSM pads, and the high/low times are $\min 1 * T_A$.
- 2) The PLL jitter is not included. It should be considered additionally, corresponding to the used baudrate. The duty cycle can be adjusted if the ABRA block is used.
- 3) Positive deviation lengthens the high time and shortens the low time of a clock period. Negative deviation does the opposite.
- 4) From FCLP rising edge.
- 5) If EN1 is configured to P13.0 the max limit is increased by 0.5ns to 2.5ns.

Table 3-76 MPm/MP+m/MPRm clock/data

Parameter	Symbol	Values			Unit	Note / Test Condition
		Min.	Typ.	Max.		
FCLPx clock period ¹⁾	t_{40} CC	$2 * T_A$	-	-	ns	MPm/MP+m/MPRm; $C_L=50\text{pF}$
Deviation from ideal duty cycle ^{2) 3)}	t_{400} CC	-8	-	$4+0.04 * C_L$	ns	MPm/MP+m; $0 < C_L < 200\text{pF}$
SOPx output delay ⁴⁾	t_{44} CC	-11	-	9	ns	MPm/MP+m; $C_L=50\text{pF}$
ENx output delay ⁴⁾	t_{45} CC	-13	-	11	ns	MPm/MP+m/MPRm; $C_L=50\text{pF}$
		-33	-	-4	ns	MPm/MP+m/MPRm; $C_L=0\text{pF}$

- 1) FCLP signal rise/fall times are the rise/fall times of the LVDSM pads, and the high/low times are $\min 1 * T_A$.
- 2) The PLL jitter is not included. It should be considered additionally, corresponding to the used baudrate. The duty cycle can be adjusted if the ABRA block is used.
- 3) Positive deviation lengthens the high time and shortens the low time of a clock period. Negative deviation does the opposite.
- 4) From FCLP rising edge.

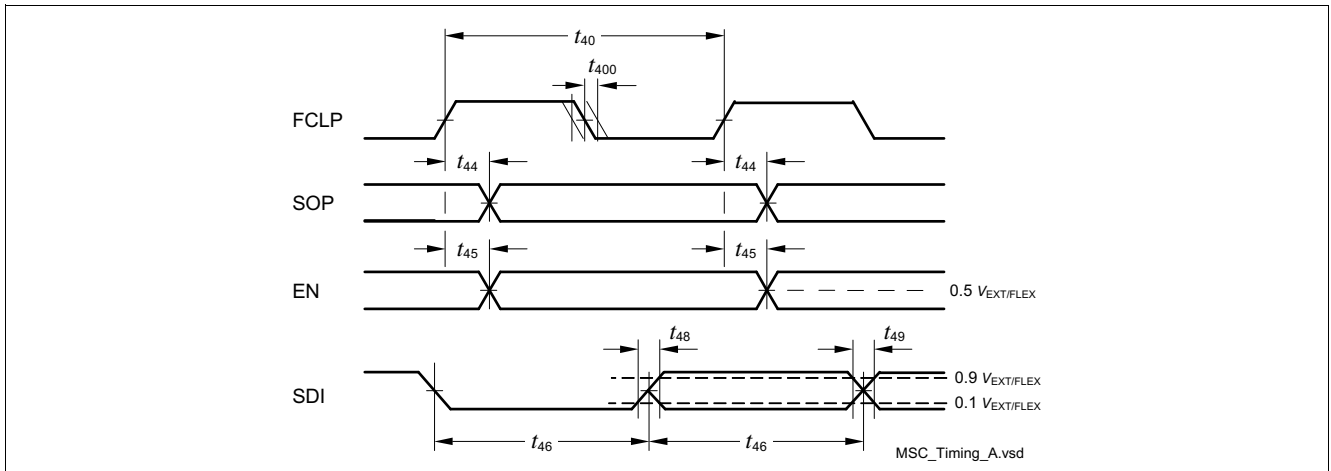
Figure 3-23 MSC Interface Timing

Note: The SOP data signal is sampled with the falling edge of FCLP in the target device.

3.28 MSC Timing 3.3 V Operation

The following section defines the timings for 3.3V pad power supply.

Note: Pad asymmetry is already included in the following timings.

Note: Load for LVDS pads are defined as differential loads in the following timings.

Mapping A, Combo Pads in LVDS Mode or CMOS Mode

The timing applies for the LVDS pads in LVDS operating mode:

- The LVDSM output pads for clock and data signals set in LVDS mode
- The CMOS MP pads for enable signals, with strong driver sharp edge (MPss) or strong driver medium edge (MPsm).

Table 3-77 LVDS clock/data (LVDS pads in LVDS mode)

Parameter	Symbol	Values			Unit	Note / Test Condition
		Min.	Typ.	Max.		
FCLPx clock period ¹⁾	t_{40} CC	$2 * T_A$ ^{2) 3)}	-	-	ns	LVDSM; $C_L=50\text{pF}$
Deviation from ideal duty cycle ^{4) 5)}	t_{400} CC	-2	-	2	ns	LVDSM; $0 < C_L < 50\text{pF}$
SOPx output delay ⁶⁾	t_{44} CC	-5	-	5	ns	LVDSM; $C_L=50\text{pF}$; option EN01
		-7	-	7	ns	LVDSM; $C_L=50\text{pF}$; option EN01D

Electrical Specification MSC Timing 3.3 V Operation

Table 3-77 LVDS clock/data (LVDS pads in LVDS mode) (cont'd)

Parameter	Symbol	Values			Unit	Note / Test Condition
		Min.	Typ.	Max.		
ENx output delay ⁶⁾	t_{45} CC	-7	-	9	ns	MP+ss/MPRss; option EN01; $C_L=25\text{pF}$
		-5	-	13	ns	MP+ss/MPRss; option EN01; $C_L=50\text{pF}$
		-5	-	26	ns	MP+sm/MPRsm; option EN01D; $C_L=50\text{pF}$
		-4	-	16	ns	MP+ss/MPRss; option EN23; $C_L=25\text{pF}$
		-4	-	17	ns	MP+ss/MPRss; option EN23; $C_L=50\text{pF}$
		-5	-	19	ns	MPss; option EN01; $C_L=50\text{pF}$
		-12	-	4	ns	MP+ss/MPRss; option EN01; $C_L=0\text{pF}$
		-9	-	11	ns	MP+sm/MPRsm; option EN01D; $C_L=0\text{pF}$
		-7	-	9	ns	MP+ss/MPRss; option EN23; $C_L=0\text{pF}$
		-12	-	7	ns	MPss; option EN01; $C_L=0\text{pF}$
SDI bit time	t_{46} CC	$8 * t_{MSC}$	-	-	ns	Upstream Timing
SDI rise time ⁷⁾	t_{48} SR	-	-	200	ns	Upstream Timing
SDI fall time ⁷⁾	t_{49} SR	-	-	200	ns	Upstream Timing

1) FCLP signal rise/fall times are the rise/fall times of the LVDSM pads, and the high/low times are $\min 1 * T_A$.

2) $T_{Amin} = T_{MAX}$. When $T_{MAX} = 100 \text{ MHz}$, $t_{40} = 20 \text{ ns}$

3) The capacitive load on the LVDS pins is differential, the capacitive load on the CMOS pins is single ended.

4) The PLL jitter is not included. It should be considered additionally, corresponding to the used baudrate. The duty cycle can be adjusted if the ABRA block is used.

5) Positive deviation lengthens the high time and shortens the low time of a clock period. Negative deviation does the opposite.

6) From FCLP rising edge.

7) When using slow and asymmetrical edges, like in case of open drain upstream connection, the application must take care that the bit is long enough (the baud rate is low enough) so that under worst case conditions the three sampling points in the middle of the bit are not violated.

Table 3-78 MPss clock/data (LVDS pads in CMOS mode, option EN01)

Parameter	Symbol	Values			Unit	Note / Test Condition
		Min.	Typ.	Max.		
FCLPx clock period ¹⁾	t_{40} CC	$2 * T_A$ ^{2) 3)}	-	-	ns	MPss; $C_L=50\text{pF}$
Deviation from ideal duty cycle ^{4) 5)}	t_{400} CC	-5	-	$7+0.07 * C_L$	ns	MPss; $0 < C_L < 100\text{pF}$

Electrical Specification MSC Timing 3.3 V Operation

Table 3-78 MPss clock/data (LVDS pads in CMOS mode, option EN01) (cont'd)

Parameter	Symbol	Values			Unit	Note / Test Condition
		Min.	Typ.	Max.		
SOPx output delay ⁶⁾	t_{44} CC	-7	-	12	ns	MPss; $C_L=50\text{pF}$
ENx output delay ⁶⁾	t_{45} CC	-9	-	12	ns	MP+ss/MPRss; $C_L=50\text{pF}$
		-4	-	26	ns	MP+sm/MPRsm; $C_L=50\text{pF}$
		-7	-	17	ns	MPss; $C_L=50\text{pF}$
		0	-	54	ns	MPsm; $C_L=50\text{pF}$; except pin P13.0
		0	-	58	ns	MPsm; $C_L=50\text{pF}$; pin P13.0
		4	-	77	ns	MPm/MP+m/MPRm; $C_L=50\text{pF}$
		-19	-	4	ns	MP+ss/MPRss; $C_L=0\text{pF}$
		-7	-	12	ns	MP+sm/MPRsm; $C_L=0\text{pF}$
		-17	-	4	ns	MPss; $C_L=0\text{pF}$
		-2	-	28	ns	MPsm; $C_L=0\text{pF}$
		-4	-	31	ns	MP+m/MPm/MPRm; $C_L=0\text{pF}$
SDI bit time	t_{46} CC	$8 * t_{MSC}$	-	-	ns	Upstream Timing
SDI rise time ⁷⁾	t_{48} SR	-	-	200	ns	Upstream Timing
SDI fall time ⁷⁾	t_{49} SR	-	-	200	ns	Upstream Timing

1) FCLP signal rise/fall times are the rise/fall times of the LVDSM pads, and the high/low times are $\min 1 * T_A$.

2) $T_{Amin} = T_{MAX}$. When $T_{MAX} = 100 \text{ MHz}$, $t_{40} = 20 \text{ ns}$

3) FCLP signal high and low can be minimum $1 * T_{MSC}$.

4) The PLL jitter is not included. It should be considered additionally, corresponding to the used baudrate. The duty cycle can be adjusted if the ABRA block is used.

5) Positive deviation lengthens the high time and shortens the low time of a clock period. Negative deviation does the opposite.

6) From FCLP rising edge.

7) When using slow and asymmetrical edges, like in case of open drain upstream connection, the application must take care that the bit is long enough (the baud rate is low enough) so that under worst case conditions the three sampling points in the middle of the bit are not violated.

Mapping B, CMOS MP Pads

This timing applies for the dedicated CMOS pads, pin Mapping B:

- MP strong sharp (MPss) output pads for the clock and the data signals
- MP strong sharp or strong medium (MPss or MPsm) output pads for enable signals

Electrical Specification MSC Timing 3.3 V Operation

Table 3-79 MP+sm/MPRsm clock/data

Parameter	Symbol	Values			Unit	Note / Test Condition
		Min.	Typ.	Max.		
FCLPx clock period ¹⁾	t_{40} CC	$2 * T_A$	-	-	ns	MP+sm/MPRsm; $C_L=50\text{pF}$
Deviation from ideal duty cycle ^{2) 3)}	t_{400} CC	-3	-	7	ns	MP+sm/MPRsm; $0 < C_L < 200\text{pF}$
SOPx output delay ⁴⁾	t_{44} CC	-9	-	12	ns	MP+sm; $C_L=50\text{pF}$
ENx output delay ⁴⁾	t_{45} CC	-20	-	4	ns	MPss; $C_L=50\text{pF}$
		-9	-	19	ns	MP+sm/MPRsm; $C_L=50\text{pF}$
		0	-	44	ns	MPsm; $C_L=50\text{pF}$
		0	-	63	ns	MP+m/MPm/MPRm; $C_L=50\text{pF}$
		-33	-	0	ns	MPss; $C_L=0\text{pF}$
		-23	-	4	ns	MP+sm/MPRsm; $C_L=0\text{pF}$
		-9	-	14	ns	MPsm; $C_L=0\text{pF}$
		-9	-	17	ns	MPm/MP+m/MPRm; $C_L=0\text{pF}$

- 1) FCLP signal rise/fall times are the rise/fall times of the LVDSM pads, and the high/low times are $\min 1 * T_A$.
- 2) The PLL jitter is not included. It should be considered additionally, corresponding to the used baudrate. The duty cycle can be adjusted if the ABRA block is used.
- 3) Positive deviation lengthens the high time and shortens the low time of a clock period. Negative deviation does the opposite.
- 4) From FCLP rising edge.

Table 3-80 MPm/MP+m/MPRm clock/data

Parameter	Symbol	Values			Unit	Note / Test Condition
		Min.	Typ.	Max.		
FCLPx clock period ¹⁾	t_{40} CC	$2 * T_A$	-	-	ns	MPm/MP+m/MPRm; $C_L=50\text{pF}$
Deviation from ideal duty cycle ^{2) 3)}	t_{400} CC	$-6-0.07 * C_L$	-	$6+0.07 * C_L$	ns	MPm/MP+m/MPRm; $0 < C_L < 200\text{pF}$
SOPx output delay ⁴⁾	t_{44} CC	-19	-	16	ns	MPm/MP+m; $C_L=50\text{pF}$
ENx output delay ⁴⁾	t_{45} CC	-19	-	20	ns	MPm/MP+m/MPRm; $C_L=50\text{pF}$
		-57	-	0	ns	MPm/MP+m/MPRm; $C_L=0\text{pF}$

- 1) FCLP signal rise/fall times are the rise/fall times of the LVDSM pads, and the high/low times are $\min 1 * T_A$.
- 2) The PLL jitter is not included. It should be considered additionally, corresponding to the used baudrate. The duty cycle can be adjusted if the ABRA block is used.
- 3) Positive deviation lengthens the high time and shortens the low time of a clock period. Negative deviation does the opposite.

Electrical Specification MSC Timing 3.3 V Operation

4) From FCLP rising edge.

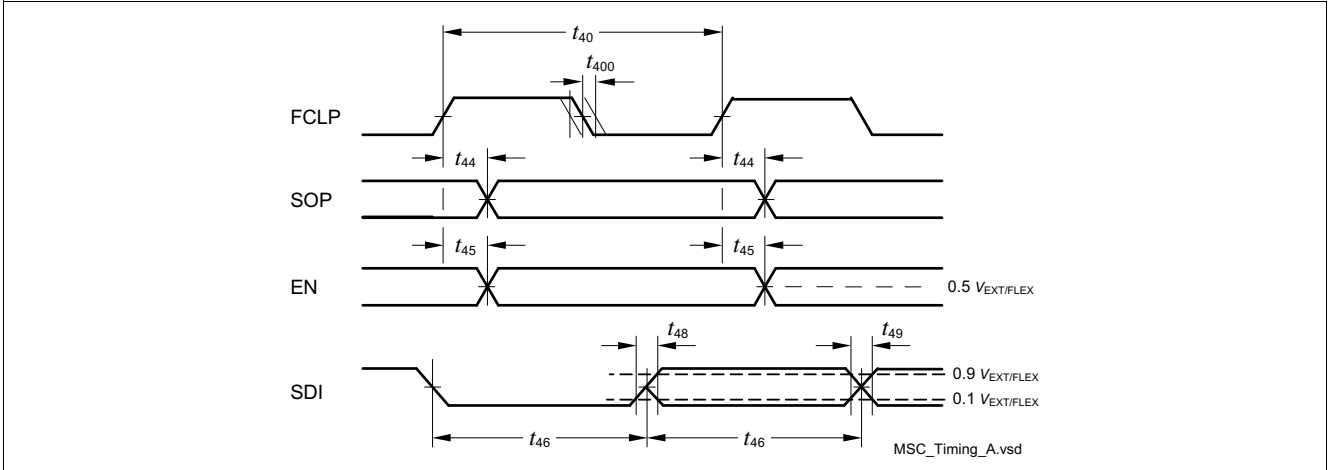

Figure 3-24 MSC Interface Timing

Note: The SOP data signal is sampled with the falling edge of FCLP in the target device.

3.29 Ethernet Interface (ETH) Characteristics

3.29.1 ETH Measurement Reference Points

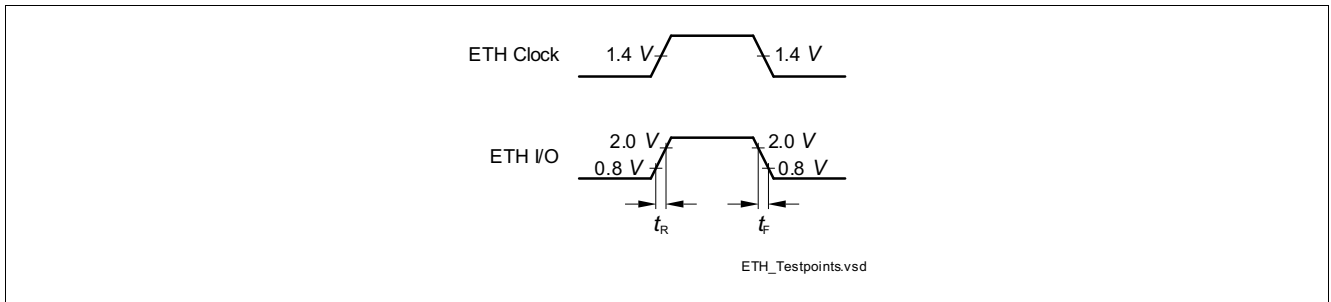
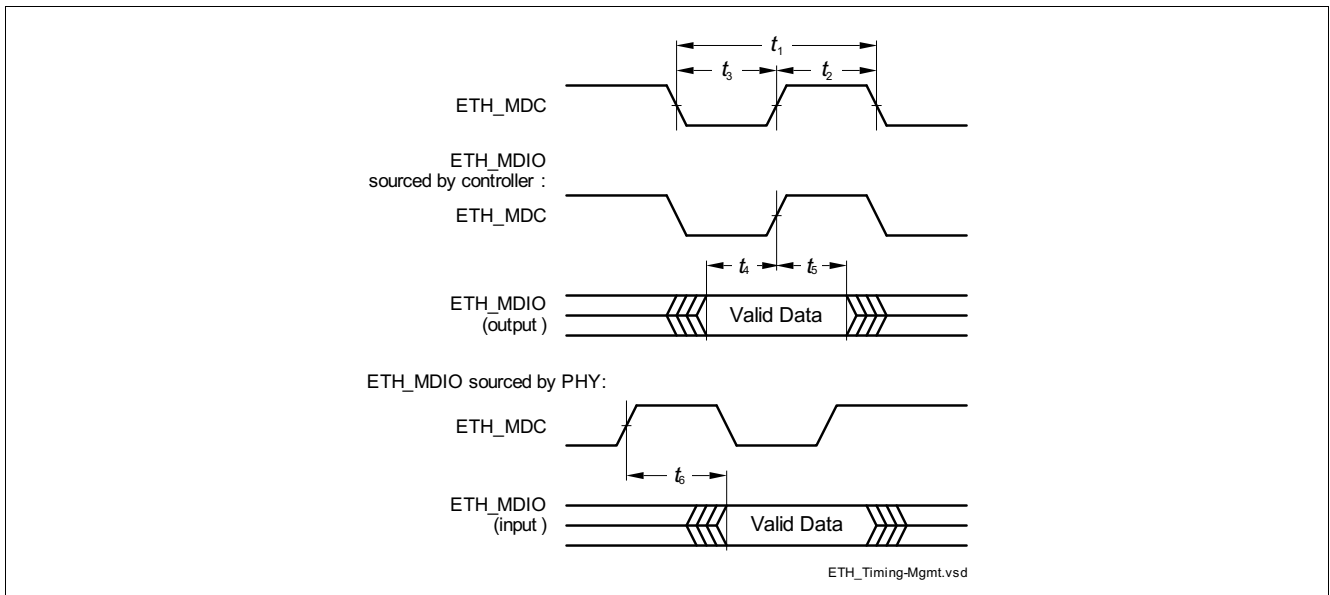

Figure 3-25 ETH Measurement Reference Points

3.29.2 ETH Management Signal Parameters (ETH_MDC, ETH_MDIO)

Table 3-81 ETH Management Signal Parameters

Parameter	Symbol	Values			Unit	Note / Test Condition
		Min.	Typ.	Max.		
ETH_MDC period	t_1 CC	400	-	-	ns	$C_L=25\text{pF}$
ETH_MDC high time	t_2 CC	160	-	-	ns	$C_L=25\text{pF}$
ETH_MDC low time	t_3 CC	160	-	-	ns	$C_L=25\text{pF}$
ETH_MDIO setup time (output)	t_4 CC	10	-	-	ns	$C_L=25\text{pF}$
ETH_MDIO hold time (output)	t_5 CC	10	-	-	ns	$C_L=25\text{pF}$
ETH_MDIO data valid (input)	t_6 SR	0	-	300	ns	$C_L=25\text{pF}$

Figure 3-26 ETH Management Signal Timing

Electrical Specification Ethernet Interface (ETH) Characteristics

3.29.3 ETH MII Parameters

In the following, the parameters of the MII (Media Independent Interface) are described.

Table 3-82 ETH MII Signal Timing Parameters

Parameter	Symbol	Values			Unit	Note / Test Condition
		Min.	Typ.	Max.		
Clock period	t_7 SR	40	-	-	ns	$C_L=25\text{pF}$; baudrate=100Mbps
		400	-	-	ns	$C_L=25\text{pF}$; baudrate=10Mbps
Clock high time	t_8 SR	14	-	26	ns	$C_L=25\text{pF}$; baudrate=100Mbps
		140 ¹⁾	-	260 ²⁾	ns	$C_L=25\text{pF}$; baudrate=10Mbps
Clock low time	t_9 SR	14	-	26	ns	$C_L=25\text{pF}$; baudrate=100Mbps
		140 ¹⁾	-	260 ²⁾	ns	$C_L=25\text{pF}$; baudrate=10Mbps
Input setup time	t_{10} SR	10	-	-	ns	$C_L=25\text{pF}$
Input hold time	t_{11} SR	10	-	-	ns	$C_L=25\text{pF}$
Output valid time	t_{12} CC	0	-	25	ns	$C_L=25\text{pF}$

1) Defined by 35% of clock period.

2) Defined by 65% of clock period.

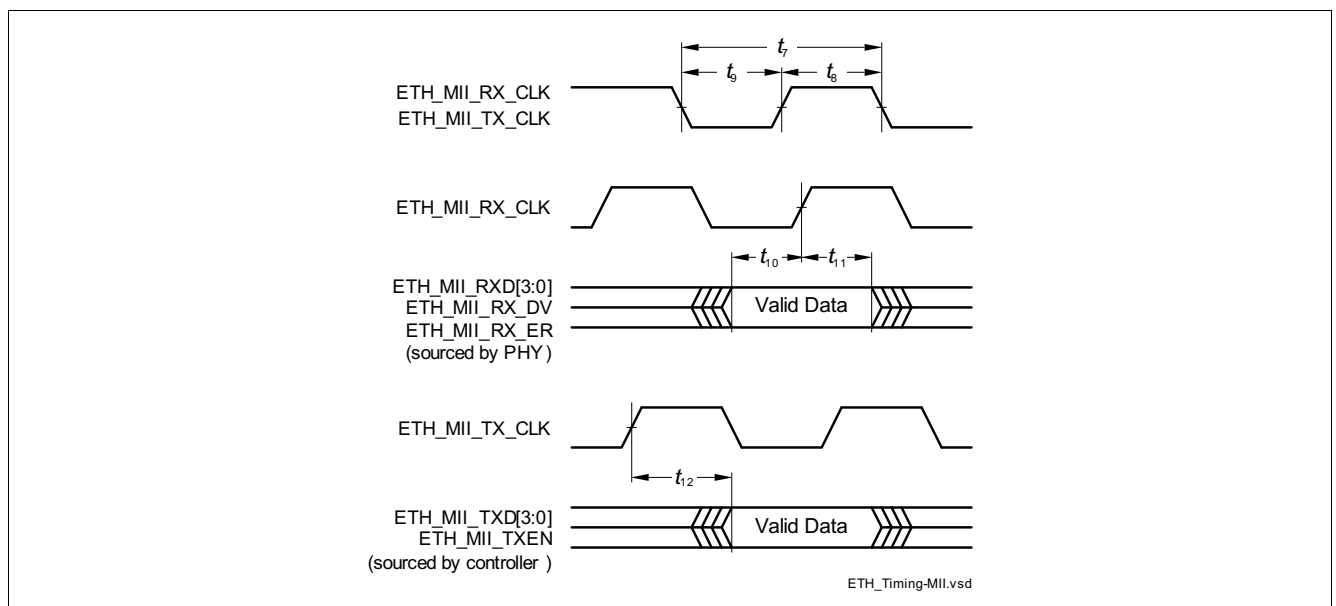

Figure 3-27 ETH MII Signal Timing

3.29.4 ETH RMII Parameters

In the following, the parameters of the RMII (Reduced Media Independent Interface) are described.

Table 3-83 ETH RMII Signal Timing Parameters

Parameter	Symbol	Values			Unit	Note / Test Condition
		Min.	Typ.	Max.		
ETH_RMII_REF_CL clock period	t_{13} CC	20	-	-	ns	$C_L=25\text{pF}$; 50ppm
ETH_RMII_REF_CL clock high time	t_{14} CC	7 ¹⁾	-	13 ²⁾	ns	$C_L=25\text{pF}$
ETH_RMII_REF_CL clock low time	t_{15} CC	7 ¹⁾	-	13 ²⁾	ns	$C_L=25\text{pF}$
ETHTXEN, ETHTXD[1:0], ETHRXD[1:0], ETHCRSDV, ETHRXER; setup time	t_{16} CC	4	-	-	ns	$C_L=25\text{pF}$
ETHTXEN, ETHTXD[1:0], ETHRXD[1:0], ETHCRSDV, ETHRXER; hold time	t_{17} CC	2	-	-	ns	$C_L=25\text{pF}$

1) Defined by 35% of clock period.

2) Defined by 65% of clock period.

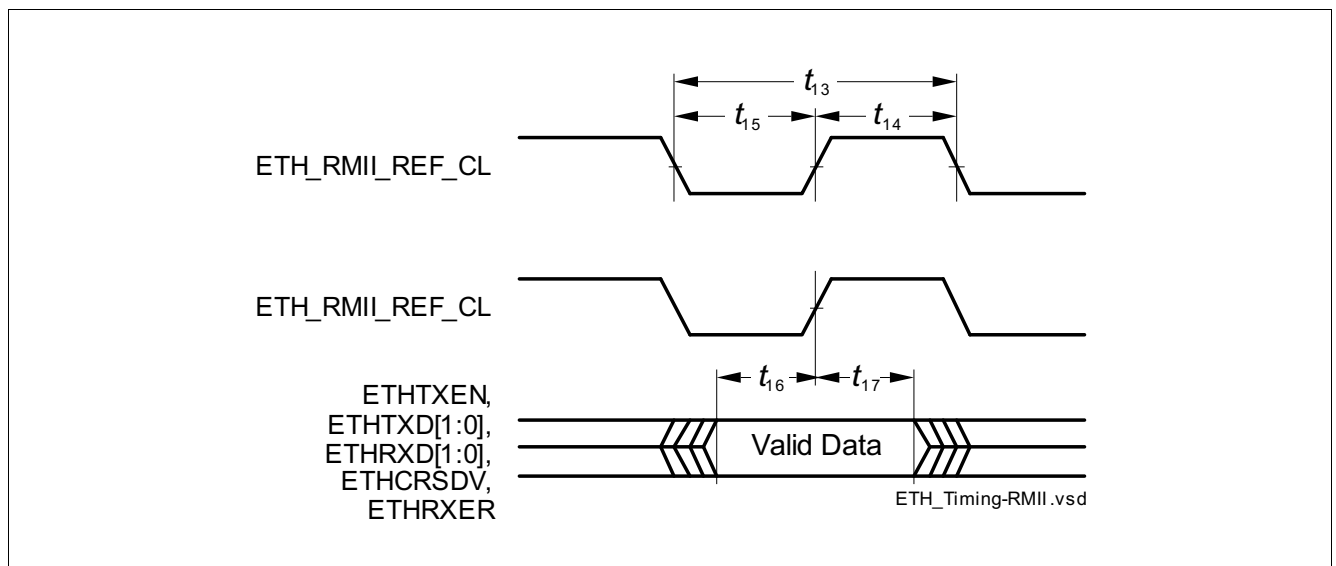

Figure 3-28 ETH RMII Signal Timing

3.30 E-Ray Parameters

The timings of this section are valid for the strong driver and either sharp edge settings of the output drivers with $C_L = 25$ pF. For the inputs the hysteresis has to be configured to inactive.

Table 3-84 Transmit Parameters

Parameter	Symbol	Values			Unit	Note / Test Condition
		Min.	Typ.	Max.		
Rise time of TxEN	$t_{dCCTxENRise25CC}$	-	-	9	ns	$C_L=25pF$
Fall time of TxEN	$t_{dCCTxENFall25CC}$	-	-	9	ns	$C_L=25pF$
Sum of rise and fall time	$t_{dCCTxRise25+dCCTxFall25CC}$	-	-	9	ns	20% - 80%; $C_L=25pF$
Sum of delay between TP1_FF and TP1_CC and delays derived from TP1_FFi, rising edge of TxEN	$t_{dCCTxEN01CC}$	-	-	25	ns	
Sum of delay between TP1_FF and TP1_CC and delays derived from TP1_FFi, falling edge of TxEN	$t_{dCCTxEN10CC}$	-	-	25	ns	
Asymmetry of sending	$t_{tx_asym} CC$	-2.45	-	2.45	ns	$C_L=25pF$
Sum of delay between TP1_FF and TP1_CC and delays derived from TP1_FFi, rising edge of TxD	$t_{dCCTxD01CC}$	-	-	25	ns	
Sum of delay between TP1_FF and TP1_CC and delays derived from TP1_FFi, falling edge of TxD	$t_{dCCTxD10CC}$	-	-	25	ns	
TxD signal sum of rise and fall time at TP1_BD	$t_{txd_sum} CC$	-	-	9	ns	

Table 3-85 Receive Parameters

Parameter	Symbol	Values			Unit	Note / Test Condition
		Min.	Typ.	Max.		
Acceptance of asymmetry at receiving part	$t_{dCCTxAsymAccept25} SR$	-30.5	-	43.0	ns	$C_L=25pF$
Acceptance of asymmetry at receiving part	$t_{dCCTxAsymAccept15} SR$	-31.5	-	44.0	ns	$C_L=15pF$
Threshold for detecting logical high	$T_{uCCLogic1} SR$	35	-	70	%	
Threshold for detecting logical low	$T_{uCCLogic0} SR$	30	-	65	%	

Table 3-85 Receive Parameters (cont'd)

Parameter	Symbol	Values			Unit	Note / Test Condition
		Min.	Typ.	Max.		
Sum of delay between TP4_CC and TP4_FF and delays derived from TP4_FFi, rising edge of RxD	$t_{dCCRxD01}$ CC	-	-	10	ns	
Sum of delay between TP1_CC and TP1_CC and delays derived from TP4_FFi, falling edge of RxD	$t_{dCCRxD10}$ CC	-	-	10	ns	

3.31 HSCT Parameters

Table 3-86 HSCT - Rx/Tx setup timing

Parameter	Symbol	Values			Unit	Note / Test Condition
		Min.	Typ.	Max.		
RX o/p duty cycle	DC_{rx} CC	40	-	60	%	
Bias startup time	t_{bias} CC	-	5	10	μ s	Bias distributor waking up from power down and provide stable Bias.
RX startup time	t_{rx} CC	-	5	-	μ s	Wake-up RX from power down.
TX startup time	t_{tx} CC	-	5	-	μ s	Wake-up TX from power down.

Table 3-87 HSCT - Rx parasitics and loads

Parameter	Symbol	Values			Unit	Note / Test Condition
		Min.	Typ.	Max.		
Capacitance total budget	C_{total} CC	-	3.5	5	pF	Total Budget for complete receiver including silicon, package, pins and bond wire
Parasitic inductance budget	H_{total} CC	-	5	-	nH	

Table 3-88 LVDSH - Reduced TX and RX (RED)

Parameter	Symbol	Values			Unit	Note / Test Condition
		Min.	Typ.	Max.		
Output differential voltage	V_{OD} CC	150	200	285	mV	$R_t = 100 \text{ Ohm } \pm 20\%$ @2pF
Output voltage high	V_{OH} CC	-	-	1463	mV	$R_t = 100 \text{ Ohm } \pm 20\%$
Output voltage low	V_{OL} CC	937	-	-	mV	$R_t = 100 \text{ Ohm } \pm 20\%$
Output offset (Common mode) voltage	V_{OS} CC	1.08	1.2	1.32	V	$R_t = 100 \text{ Ohm } \pm 20\%$ @2pF
Input voltage range	V_I SR	-	-	1.6	V	Absolute max = $1.6 \text{ V} + (285\text{mV}/2) = 1.743$
		0.15	-	-	V	Absolute min = $0.15 \text{ V} - (285 \text{ mV} / 2) = 0 \text{ V}$
Input differential threshold	V_{idth} SR	-100	-	100	mV	100 mV for 55% of bit period; Note Absolute Value ($V_{idth} - V_{idthl}$)
Data frequency	DR CC	5	-	320	Mbps	

Electrical Specification HSCT Parameters

Table 3-88 LVDSH - Reduced TX and RX (RED) (cont'd)

Parameter	Symbol	Values			Unit	Note / Test Condition
		Min.	Typ.	Max.		
Receiver differential input impedance	R_{in} CC	90	100	110	Ohm	$0\text{ V} < V_I < 1.6\text{V}$
		80	100	120	Ohm	$1.6\text{ V} < V_I < 2.0\text{V}$
Slew rate	SR_{tx} CC	-	-	2	V/ns	
Change in VOS between 0 and 1	$dVOS$ CC	-	-	50	mV	Peak to peak (including DC transients).
Change in Vod between 0 and 1	$dVod$ CC	-	-	50	mV	Peak to peak (including DC transients)
Fall time ¹⁾	t_{fall} CC	0.26	-	1.2	ns	$R_t = 100\text{ Ohm} \pm 20\%$ @2pF
Rise time ¹⁾	t_{rise} CC	0.26	-	1.2	ns	$R_t = 100\text{ Ohm} \pm 20\%$ @2pF

1) Rise / fall times are defined for 10% - 90% of V_{OD}

Table 3-89 HSCT PLL

Parameter	Symbol	Values			Unit	Note / Test Condition
		Min.	Typ.	Max.		
PLL frequency range	f_{PLL} CC	12.5	320	320	MHz	
PLL input frequency	f_{REF} CC	10	-	20	MHz	
PLL lock-in time	t_{LOCK} CC	-	-	50	μs	
Bit Error Rate based on 10 MHz reference clock at Slave PLL side	BER_{10} CC	-	-	10EXP-9	-	Bit Error Rate based on Slave interface reference clock at 10 MHz
Bit Error Rate based on 20 MHz reference clock at Slave PLL side	BER_{20} CC	-	-	10EXP-12	-	Bit Error Rate based on Slave interface reference clock at 20 MHz
Absolute RMS Jitter (TX out)	J_{ABS10} CC	-125	-	125	ps	Measured at link TX out; valid for Reference frequency at 10 MHz
Absolute RMS Jitter (TX out)	J_{ABS20} CC	-85	-	85	ps	Measured at link TX out; valid for Reference frequency at 20 MHz

Electrical Specification HSCT Parameters

Table 3-89 HSCT PLL (cont'd)

Parameter	Symbol	Values			Unit	Note / Test Condition
		Min.	Typ.	Max.		
Accumulated RMS Jitter (RX side)	J_{ACC10} CC	-	-	145	ps	Measured at link RX input, based on 5000 measures, each 300 clock cycles; valid for Reference frequency at 10 MHz
Accumulated RMS Jitter (link RX side)	J_{ACC20} CC	-	-	115	ps	Measured at link RX input, based on 5000 measures, each 300 clock cycles; valid for Reference frequency at 20 MHz
Total Jitter peak to peak	TJ_{pp} CC	-	-	2083	ps	Total Jitter as sum of deterministic jitter and random jitter

Table 3-90 HSCT Sysclk

Parameter	Symbol	Values			Unit	Note / Test Condition
		Min.	Typ.	Max.		
Frequency	f_{SYSCLK} CC	10	-	20	MHz	
Frequency error	$dfERR$ CC	-1	-	1	%	
Duty Cycle	DC_{sys} CC	45	-	55	%	
Load impedance	R_{LOAD} CC	10	-	-	kOhm	
Load capacitance	C_{LOAD} CC	-	-	10	pF	
Integrated phase noise	I_{PN} CC	-	-	-58	dB	single sideband phase noise in 10 kHz to 10 Mhz at 20 MHz SysClk

3.32 Inter-IC (I2C) Interface Timing

This section defines the timings for I2C in the TC 260 / 264 / 265 / 267.

All I2C timing parameter are SR for Master Mode and CC for Slave Mode.

Table 3-91 I2C Standard Mode Timing

Parameter	Symbol	Values			Unit	Note / Test Condition
		Min.	Typ.	Max.		
Fall time of both SDA and SCL	t_1	-	-	300	ns	Measured with a pull-up resistor of 4.7 kohms at each of the SCL and SDA line
Capacitive load for each bus line	C_b SR	-	-	400	pF	
Bus free time between a STOP and ATART condition	t_{10}	4.7	-	-	μ s	Measured with a pull-up resistor of 4.7 kohms at each of the SCL and SDA line
Rise time of both SDA and SCL	t_2	-	-	1000	ns	Measured with a pull-up resistor of 4.7 kohms at each of the SCL and SDA line
Data hold time	t_3	0	-	-	μ s	Measured with a pull-up resistor of 4.7 kohms at each of the SCL and SDA line
Data set-up time	t_4	250	-	-	ns	Measured with a pull-up resistor of 4.7 kohms at each of the SCL and SDA line
Low period of SCL clock	t_5	4.7	-	-	μ s	Measured with a pull-up resistor of 4.7 kohms at each of the SCL and SDA line
High period of SCL clock	t_6	4	-	-	μ s	Measured with a pull-up resistor of 4.7 kohms at each of the SCL and SDA line
Hold time for the (repeated) START condition	t_7	4	-	-	μ s	Measured with a pull-up resistor of 4.7 kohms at each of the SCL and SDA line

Electrical Specification Inter-IC (I2C) Interface Timing

Table 3-91 I2C Standard Mode Timing (cont'd)

Parameter	Symbol	Values			Unit	Note / Test Condition
		Min.	Typ.	Max.		
Set-up time for (repeated) START condition	t_8	4.7	-	-	μs	Measured with a pull-up resistor of 4.7 kohms at each of the SCL and SDA line
Set-up time for STOP condition	t_9	4	-	-	μs	Measured with a pull-up resistor of 4.7 kohms at each of the SCL and SDA line

Table 3-92 I2C Fast Mode Timing

Parameter	Symbol	Values			Unit	Note / Test Condition
		Min.	Typ.	Max.		
Fall time of both SDA and SCL	t_1	$20+0.1 \cdot C_b$	-	300	ns	Measured with a pull-up resistor of 4.7 kohms at each of the SCL and SDA line
Capacitive load for each bus line	C_b SR	-	-	400	pF	
Bus free time between a STOP and ATART condition	t_{10}	1.3	-	-	μs	Measured with a pull-up resistor of 4.7 kohms at each of the SCL and SDA line
Rise time of both SDA and SCL	t_2	$20+0.1 \cdot C_b$	-	300	ns	Measured with a pull-up resistor of 4.7 kohms at each of the SCL and SDA line
Data hold time	t_3	0	-	-	μs	Measured with a pull-up resistor of 4.7 kohms at each of the SCL and SDA line
Data set-up time	t_4	100	-	-	ns	Measured with a pull-up resistor of 4.7 kohms at each of the SCL and SDA line
Low period of SCL clock	t_5	1.3	-	-	μs	Measured with a pull-up resistor of 4.7 kohms at each of the SCL and SDA line
High period of SCL clock	t_6	0.6	-	-	μs	Measured with a pull-up resistor of 4.7 kohms at each of the SCL and SDA line

Electrical Specification Inter-IC (I2C) Interface Timing

Table 3-92 I2C Fast Mode Timing (cont'd)

Parameter	Symbol	Values			Unit	Note / Test Condition
		Min.	Typ.	Max.		
Hold time for the (repeated) START condition	t_7	0.6	-	-	μs	Measured with a pull-up resistor of 4.7 kohms at each of the SCL and SDA line
Set-up time for (repeated) START condition	t_8	0.6	-	-	μs	Measured with a pull-up resistor of 4.7 kohms at each of the SCL and SDA line
Set-up time for STOP condition	t_9	0.6	-	-	μs	Measured with a pull-up resistor of 4.7 kohms at each of the SCL and SDA line

3.33 SCR Parameters

3.33.1 SSC Timing 5V

It is assumed that SCLKO and MTSR pads have the same pad settings:

- Medium Performance Plus Pads (MP+):
 - strong sharp edge (MP+ss), $C_L=25\text{pF}$
 - strong medium edge (MP+sm), $C_L=50\text{pF}$
 - medium edge (MP+m), $C_L=50\text{pF}$
 - weak edge (MP+w), $C_L=50\text{pF}$
- Medium Performance Pads (MP):
 - strong sharp edge (MPss), $C_L=25\text{pF}$
 - strong medium edge (MPsm), $C_L=50\text{pF}$
- Medium and Low Performance Pads (MP/LP), the identical output strength settings:
 - medium edge (LP/MPm), $C_L=50\text{pF}$
 - weak edge (MPw), $C_L=50\text{pF}$

Table 3-93 Master Mode timing MPsm output pads

Parameter	Symbol	Values			Unit	Note / Test Condition
		Min.	Typ.	Max.		
SCLKO clock period ¹⁾	t_{50} CC	100	-	-	ns	$C_L=50\text{pF}$
Deviation from the ideal duty cycle ^{2) 3)}	t_{500} CC	-10	-	10	ns	$C_L=50\text{pF}$
MTSR delay from SCLKO shifting edge	t_{51} CC	-10	-	10	ns	$C_L=50\text{pF}$
MRST hold from SCLK latching edge	t_{53} SR	-10 ^{4) 5)}	-	-	ns	$C_L=50\text{pF}$

1) Documented value is valid for master transmit or slave receive only. For full duplex the external SPI counterpart timing has to be taken into account.

2) The PLL jitter is not included. It should be considered additionally, corresponding to the used baudrate. The duty cycle can be adjusted using the bit fields ECONz.A, B and C with the finest granularity of $T_{MAX} = 1 / f_{MAX}$.

3) Positive deviation lengthens the high time and shortens the low time of a clock period. Negative deviation does the opposite.

4) For compensation of the average on-chip delay the QSPI module provides the bit fields ECONz.A, B and C.

5) The setup and hold times are valid for both settings of the input pads thresholds: TTL and AL.

Table 3-94 Master Mode timing MP+m/MPm/LPm output pads

Parameter	Symbol	Values			Unit	Note / Test Condition
		Min.	Typ.	Max.		
SCLKO clock period ¹⁾	t_{50} CC	200	-	-	ns	$C_L=50\text{pF}$
Deviation from the ideal duty cycle ^{2) 3)}	t_{500} CC	-15	-	15	ns	$C_L=50\text{pF}$
MTSR delay from SCLKO shifting edge	t_{51} CC	-15	-	15	ns	$C_L=50\text{pF}$

Electrical Specification SCR Parameters

Table 3-94 Master Mode timing MP+m/MPm/LPm output pads (cont'd)

Parameter	Symbol	Values			Unit	Note / Test Condition
		Min.	Typ.	Max.		
MRST setup to SCLK latching edge ⁴⁾	t_{52} SR	-70 ⁴⁾⁵⁾	-	-	ns	$C_L=50\text{pF}$
MRST hold from SCLK latching edge	t_{53} SR	-10 ⁴⁾⁵⁾	-	-	ns	$C_L=50\text{pF}$

- 1) Documented value is valid for master transmit or slave receive only. For full duplex the external SPI counterpart timing has to be taken into account.
- 2) The PLL jitter is not included. It should be considered additionally, corresponding to the used baudrate. The duty cycle can be adjusted using the bit fields ECONz.A, B and C with the finest granularity of $T_{MAX} = 1 / f_{MAX}$.
- 3) Positive deviation lengthens the high time and shortens the low time of a clock period. Negative deviation does the opposite.
- 4) For compensation of the average on-chip delay the QSPI module provides the bit fields ECONz.A, B and C.
- 5) The setup and hold times are valid for both settings of the input pads thresholds: TTL and AL.

Table 3-95 Slave mode timing

Parameter	Symbol	Values			Unit	Note / Test Condition
		Min.	Typ.	Max.		
SCLK clock period	t_{54} SR	4 x TSSC	-	-	ns	
SCLK duty cycle	t_{55}/t_{54} SR	40	-	60	%	
MtSR setup to SCLK latching edge	t_{56} SR	40 ¹⁾	-	-	ns	
MtSR hold from SCLK latching edge	t_{57} SR	3	-	-	ns	
SLSI setup to first SCLK shift edge	t_{58} SR	3 ¹⁾	-	-	ns	
MRST delay from SCLK shift edge	t_{60} CC	10	-	70	ns	MP+m; $C_L=50\text{pF}$
		10	-	50	ns	MP+sm; $C_L=50\text{pF}$
		5	-	30	ns	MP+ss; $C_L=25\text{pF}$
		100	-	300	ns	MP+w; $C_L=50\text{pF}$
		10	-	70	ns	MPm/LPm; $C_L=50\text{pF}$
		10	-	50	ns	MPsm; $C_L=50\text{pF}$
		5	-	30	ns	MPss; $C_L=25\text{pF}$
		100	-	300	ns	MPw/LPw; $C_L=50\text{pF}$

- 1) The setup and hold times are valid for both settings of the input pads thresholds: TTL and AL.

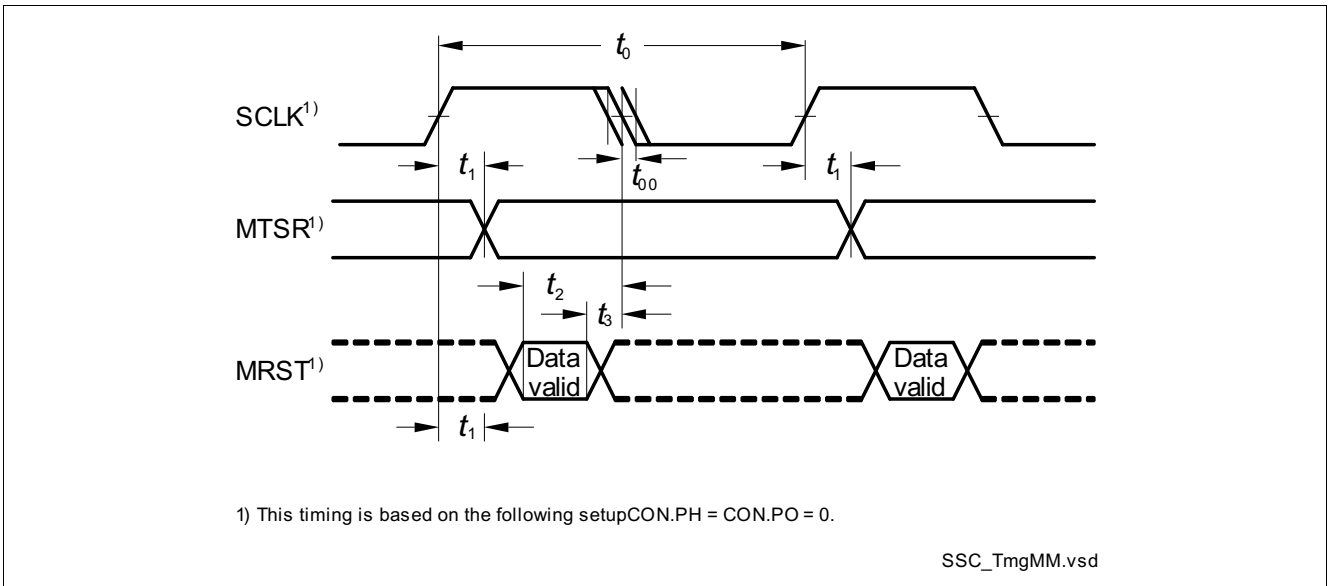

Figure 3-29 Master Mode Timing

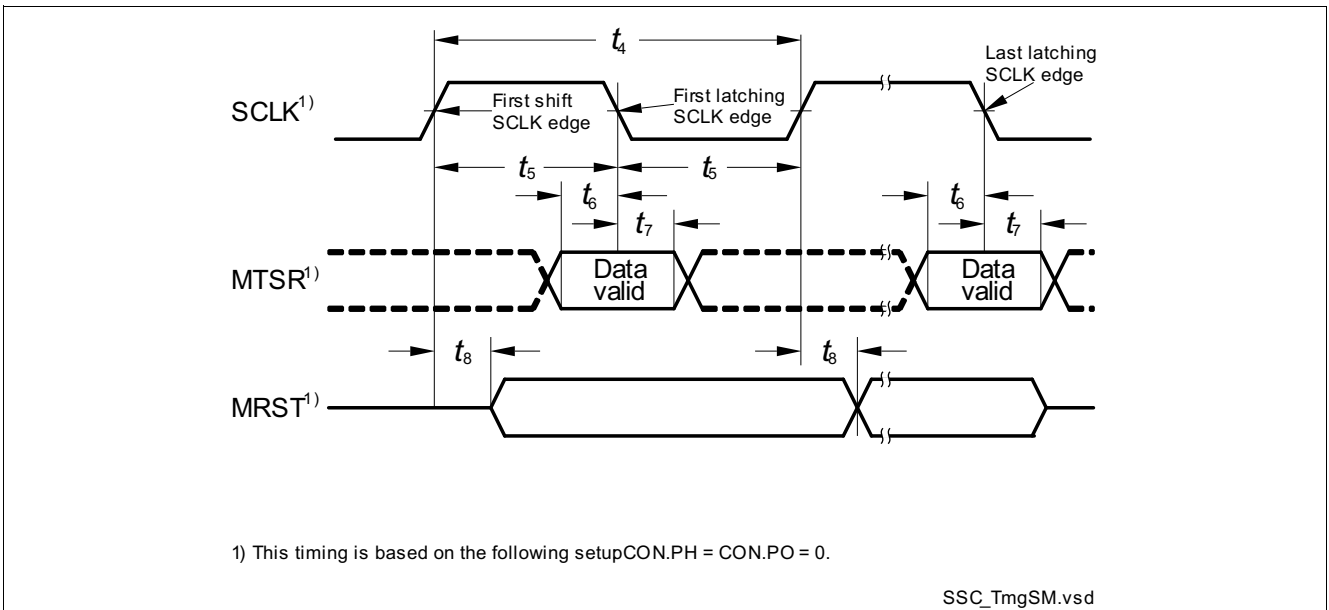

Figure 3-30 Slave Mode Timing

3.33.2 SPD Timing

The SPD interface will work with standard SPD tools having a sample/output clock frequency deviation of +/- 5% or less. For further details please refer to application note AP24004 in section SPD Timing Requirements.

3.33.3 WCAN Timing

The following table defines the timing parameter for the WCAN filter.

Table 3-96 WCAN

Parameter	Symbol	Values			Unit	Note / Test Condition
		Min.	Typ.	Max.		
Timeout for bus inactivity	$t_{\text{SILENCE SR}}$	0.6	0.75	1.2	s	

3.34 CIF Parameters

Table 3-97 Timings for 5V

Parameter	Symbol	Values			Unit	Note / Test Condition
		Min.	Typ.	Max.		
Pixel clock period	t_{70} SR	10.42	-	-	ns	96 MHz
HSYNC, VSYNC set up time	t_{71} SR	2.5	-	-	ns	AL input level, hysteresis bypass
		2	-	-	ns	TTL input level, hysteresis bypass
		6.5	-	-	ns	TTL input level, hysteresis on
		4	-	-	ns	AL input level, hysteresis on
HSYNC, VSYNC hold time	t_{72} SR	2.5	-	-	ns	AL input level, hysteresis bypass
		2.5	-	-	ns	TTL input level, hysteresis bypass
		7	-	-	ns	TTL input level, hysteresis on
		4	-	-	ns	AL input level, hysteresis on
Pixel data set up time	t_{73} SR	2.5	-	-	ns	AL input level, hysteresis bypass
		2	-	-	ns	TTL input level, hysteresis bypass
		6.5	-	-	ns	TTL input level, hysteresis on
		4	-	-	ns	AL input level, hysteresis on
Pixel data hold time	t_{74} SR	2.5	-	-	ns	AL input level, hysteresis bypass
		2.5	-	-	ns	TTL input level, hysteresis bypass
		7	-	-	ns	TTL input level, hysteresis on
		4	-	-	ns	AL input level, hysteresis on

Table 3-98 Timings for 3.3V

Parameter	Symbol	Values			Unit	Note / Test Condition
		Min.	Typ.	Max.		
Pixel clock period	t_{70} SR	10.42	-	-	ns	
HSYNC, VSYNC set up time	t_{71} SR	3.5	-	-	ns	AL input level, hysteresis bypass
		4.5	-	-	ns	AL input level, hysteresis on
		9	-	-	ns	TTL input level, hysteresis on
		3	-	-	ns	TTL input level, hysteresis bypass
HSYNC, VSYNC hold time	t_{72} SR	4	-	-	ns	AL input level, hysteresis bypass
		5	-	-	ns	AL input level, hysteresis on
		10	-	-	ns	TTL input level, hysteresis on
		3.5	-	-	ns	TTL input level, hysteresis bypass
Pixel data set up time	t_{73} SR	3.5	-	-	ns	AL input level, hysteresis bypass
		4.5	-	-	ns	AL input level, hysteresis on
		9	-	-	ns	TTL input level, hysteresis on
		3	-	-	ns	TTL input level, hysteresis bypass
Pixel data hold time	t_{74} SR	4	-	-	ns	AL input level, hysteresis bypass
		5	-	-	ns	AL input level, hysteresis on
		10	-	-	ns	TTL input level, hysteresis on
		3.5	-	-	ns	TTL input level, hysteresis bypass

Table 3-99 Timings for 0.4V to 2.4V input signals (2.8V imager)

Parameter	Symbol	Values			Unit	Note / Test Condition
		Min.	Typ.	Max.		
Pixel clock period	t_{70} SR	10.42	-	-	ns	

Electrical Specification CIF Parameters

Table 3-99 Timings for 0.4V to 2.4V input signals (2.8V imager) (cont'd)

Parameter	Symbol	Values			Unit	Note / Test Condition
		Min.	Typ.	Max.		
HSYNC, VSYNC set up time	t_{71} SR	3	-	-	ns	Hysteresis Bypass, 3.3V±10%
		9	-	-	ns	TTL Input Levels, 3.3V±10%
		4.5	-	-	ns	TTL Input Levels, 5V±10%
HSYNC, VSYNC hold time	t_{72} SR	3.5	-	-	ns	Hysteresis Bypass, 3.3V±10%
		10	-	-	ns	TTL Input Levels, 3.3V±10%
		5	-	-	ns	TTL Input Levels, 5V±10%
Pixel data set up time	t_{73} SR	3	-	-	ns	Hysteresis Bypass, 3.3V±10%
		9	-	-	ns	TTL Input Levels, 3.3V±10%
		4.5	-	-	ns	TTL Input Levels, 5V±10%
Pixel data hold time	t_{74} SR	3.5	-	-	ns	Hysteresis Bypass, 3.3V±10%
		10	-	-	ns	TTL Input Levels, 3.3V±10%
		5	-	-	ns	TTL Input Levels, 5V±10%

Table 3-100 Timings for 0.4V to 2.4V input signals (2.8V imager), ± 5% pad power supply

Parameter	Symbol	Values			Unit	Note / Test Condition
		Min.	Typ.	Max.		
Pixel clock period	t_{70} SR	10.42	-	-	ns	
HSYNC, VSYNC set up time	t_{71} SR	3	-	-	ns	Hysteresis Bypass, 3.3V±5%
		9	-	-	ns	TTL Input Levels, 3.3V±5%
		4.5	-	-	ns	TTL Input Levels, 5V±5%
HSYNC, VSYNC hold time	t_{72} SR	3.5	-	-	ns	Hysteresis Bypass, 3.3V±5%
		10	-	-	ns	TTL Input Levels, 3.3V±5%
		5	-	-	ns	TTL Input Levels, 5V±5%

Electrical Specification CIF Parameters

Table 3-100 Timings for 0.4V to 2.4V input signals (2.8V imager), ± 5% pad power supply (cont'd)

Parameter	Symbol	Values			Unit	Note / Test Condition
		Min.	Typ.	Max.		
Pixel data set up time	t_{73} SR	3	-	-	ns	Hysteresis Bypass, 3.3V±5%
		9	-	-	ns	TTL Input Levels, 3.3V±5%
		4.5	-	-	ns	TTL Input Levels, 5V±5%
Pixel data hold time	t_{74} SR	3.5	-	-	ns	Hysteresis Bypass, 3.3V±5%
		10	-	-	ns	TTL Input Levels, 3.3V±5%
		5	-	-	ns	TTL Input Levels, 5V±5%

Table 3-101 Timings for 1.8V imager, TTL input level

Parameter	Symbol	Values			Unit	Note / Test Condition
		Min.	Typ.	Max.		
Pixel clock period	t_{70} SR	10.42	-	-	ns	
HSYNC, VSYNC set up time	t_{71} SR	3	-	-	ns	Input signal 0.1V to 1.7V
		9	-	-	ns	Input signal 0.2V to 1.6V
		4.5	-	-	ns	Input signal 0.3V to 1.5V
		3.5	-	-	ns	Input signal 0.4V to 1.4V
HSYNC, VSYNC hold time	t_{72} SR	3.5	-	-	ns	Input signal 0.1V to 1.7V
		10	-	-	ns	Input signal 0.2V to 1.6V
		5	-	-	ns	Input signal 0.3V to 1.5V
		4	-	-	ns	Input signal 0.4V to 1.4V
Pixel data set up time	t_{73} SR	3	-	-	ns	Input signal 0.1V to 1.7V
		9	-	-	ns	Input signal 0.2V to 1.6V
		4.5	-	-	ns	Input signal 0.3V to 1.5V
		3.5	-	-	ns	Input signal 0.4V to 1.4V

Table 3-101 Timings for 1.8V imager, TTL input level (cont'd)

Parameter	Symbol	Values			Unit	Note / Test Condition
		Min.	Typ.	Max.		
Pixel data hold time	t_{74} SR	3.5	-	-	ns	Input signal 0.1V to 1.7V
		10	-	-	ns	Input signal 0.2V to 1.6V
		5	-	-	ns	Input signal 0.3V to 1.5V
		4	-	-	ns	Input signal 0.4V to 1.4V

Table 3-102 Timings for 1.8V imager, 3.3V ± 5% pad power supply, TTL input level

Parameter	Symbol	Values			Unit	Note / Test Condition
		Min.	Typ.	Max.		
Pixel clock period	t_{70} SR	10.42	-	-	ns	
HSYNC, VSYNC set up time	t_{71} SR	3	-	-	ns	Input signal 0.1V to 1.7V
		9	-	-	ns	Input signal 0.2V to 1.6V
		4.5	-	-	ns	Input signal 0.3V to 1.5V
		3.5	-	-	ns	Input signal 0.4V to 1.4V
HSYNC, VSYNC hold time	t_{72} SR	3.5	-	-	ns	Input signal 0.1V to 1.7V
		10	-	-	ns	Input signal 0.2V to 1.6V
		5	-	-	ns	Input signal 0.3V to 1.5V
		4	-	-	ns	Input signal 0.4V to 1.4V
Pixel data set up time	t_{73} SR	3	-	-	ns	Input signal 0.1V to 1.7V
		9	-	-	ns	Input signal 0.2V to 1.6V
		4.5	-	-	ns	Input signal 0.3V to 1.5V
		3.5	-	-	ns	Input signal 0.4V to 1.4V

Table 3-102 Timings for 1.8V imager, 3.3V ± 5% pad power supply, TTL input level (cont'd)

Parameter	Symbol	Values			Unit	Note / Test Condition
		Min.	Typ.	Max.		
Pixel data hold time	t_{74} SR	3.5	-	-	ns	Input signal 0.1V to 1.7V
		10	-	-	ns	Input signal 0.2V to 1.6V
		5	-	-	ns	Input signal 0.3V to 1.5V
		4	-	-	ns	Input signal 0.4V to 1.4V

3.35 Flash Target Parameters

Program Flash program and erase operation is only allowed up the $T_j = 150^\circ\text{C}$.

Table 3-103 FLASH

Parameter	Symbol	Values			Unit	Note / Test Condition
		Min.	Typ.	Max.		
Program Flash Erase Time per logical sector	$t_{\text{ERP}} \text{ CC}$	-	-	1	s	cycle count < 1000
		-	$0.207 + 0.003 * (S \text{ [KByte]} / (f_{\text{FSI}} \text{ [MHz]})^1)$	-	s	cycle count < 1000, for sector of size S
Program Flash Erase Time per Multi-Sector Command	$t_{\text{MERP}} \text{ CC}$	-	-	1	s	For consecutive logical sectors in a physical sector, cycle count < 1000
		-	$0.207 + 0.003 * (S \text{ [KByte]} / (f_{\text{FSI}} \text{ [MHz]})^1)$	-	s	For consecutive logical sector range of size S in a physical sector, cycle count < 1000
Program Flash program time per page in 5 V mode	$t_{\text{PRP5}} \text{ CC}$	-	-	$50 + 3000 / (f_{\text{FSI}} \text{ [MHz]})$	μs	32 Byte
Program Flash program time per page in 3.3 V mode	$t_{\text{PRP3}} \text{ CC}$	-	-	$81 + 3400 / (f_{\text{FSI}} \text{ [MHz]})$	μs	32 Byte
Program Flash program time per burst in 5 V mode	$t_{\text{PRPB5}} \text{ CC}$	-	-	$125 + 9500 / (f_{\text{FSI}} \text{ [MHz]})$	μs	256 Byte
Program Flash program time per burst in 3.3 V mode	$t_{\text{PRPB3}} \text{ CC}$	-	-	$410 + 12000 / (f_{\text{FSI}} \text{ [MHz]})$	μs	256 Byte
Program Flash program time for 1 MByte with burst programming in 3 V mode excluding communication	$t_{\text{PRPB3_1MB}} \text{ CC}$	-	-	2.2	s	Derived value for documentation purpose, valid for $f_{\text{FSI}} = 100\text{MHz}$
Program Flash program time for 1 MByte with burst programming in 5 V mode excluding communication	$t_{\text{PRPB5_1MB}} \text{ CC}$	-	-	0.9	s	Derived value for documentation purpose, valid for $f_{\text{FSI}} = 100\text{MHz}$
Program Flash program time for complete PFlash with burst programming in 5 V mode excluding communication	$t_{\text{PRPB5_PF}} \text{ CC}$	-	-	2.3	s	Derived value for documentation purpose, valid for $f_{\text{FSI}} = 100\text{MHz}$

Electrical Specification Flash Target Parameters

Table 3-103 FLASH (cont'd)

Parameter	Symbol	Values			Unit	Note / Test Condition
		Min.	Typ.	Max.		
Write Page Once adder	t_{ADD} CC	-	-	$15 + 500/(f_{FSI} \text{ [MHz]})$	μs	Adder to Program Time when using Write Page Once
Program Flash suspend to read latency	t_{SPNDP} CC	-	-	$12000/(f_{FSI} \text{ [MHz]})$	μs	For Write Burst, Verify Erased and for multi-(logical) sector erase commands
Data Flash Erase Time per Sector ²⁾	t_{ERD} CC	-	$0.12 + 0.08/(f_{FSI} \text{ [MHz]})^{1)}$	-	s	cycle count < 1000
		-	$0.57 + 0.15/(f_{FSI} \text{ [MHz]})^{1)}$	$0.928 + 0.15/(f_{FSI} \text{ [MHz]})$	s	cycle count < 125000
Data Flash Erase Time per Multi-Sector Command ²⁾	t_{MERD} CC	-	$0.12 + 0.01 * (S \text{ [KByte]}) / (f_{FSI} \text{ [MHz]})^{1)}$	-	s	For consecutive logical sector range of size S, cycle count < 1000
		-	$0.57 + 0.019 * (S \text{ [KByte]}) / (f_{FSI} \text{ [MHz]})^{1)}$	$0.928 + 0.019 * (S \text{ [KByte]}) / (f_{FSI} \text{ [MHz]})$	s	For consecutive logical sector range of size S, cycle count < 125000
Data Flash erase disturb limit	N_{DFD} CC	-	-	50	cycles	
Program time data flash per page ³⁾	t_{PRD} CC	-	-	$50 + 2500/(f_{FSI} \text{ [MHz]})^{3)}$	μs	8 Byte
Complete Device Flash Erase Time PFlash and DFlash ⁴⁾	t_{ER_Dev} CC	-	-	6	s	Derived value for documentation purpose, valid for $f_{FSI} = 100\text{MHz}$
Data Flash program time per burst ³⁾	t_{PRDB} CC	-	-	$96 + 4400/(f_{FSI} \text{ [MHz]})^{3)}$	μs	32 Bytes
Data Flash suspend to read latency	t_{SPNDD} CC	-	-	$12000/(f_{FSI} \text{ [MHz]})$	μs	
Wait time after margin change	$t_{FL_MarginDel}$ CC	-	-	10	μs	
Program Flash Retention Time, Sector	t_{RET} CC	20	-	-	years	Max. 1000 erase/program cycles
Data Flash Endurance per EEPROMx sector ⁵⁾	N_{E_EEP10} CC	125000	-	-	cycles	Max. data retention time 10 years

Electrical Specification Flash Target Parameters

Table 3-103 FLASH (cont'd)

Parameter	Symbol	Values			Unit	Note / Test Condition
		Min.	Typ.	Max.		
Data Flash Endurance per HSMx sector ⁵⁾	N_{E_HSM} CC	125000	-	-	cycles	Max. data retention time 10 years
UCB Retention Time	t_{RTU} CC	20	-	-	years	Max. 100 erase/program cycles per UCB, max 400 erase/program cycles in total
Data Flash access delay	t_{DF} CC	-	-	100	ns	see PMU_FCON.WSDFLASH
Data Flash ECC Delay	t_{DFECC} CC	-	-	20	ns	see PMU_FCON.WSECDF
Program Flash access delay	t_{PF} CC	-	-	30	ns	see PMU_FCON.WSPFLASH
Program Flash ECC delay	t_{PFECC} CC	-	-	10	ns	see PMU_FCON.WSECPF
Number of erase operations on DF0 over lifetime	N_{ERD0} CC	-	-	750000	cycles	
Junction temperature limit for PFlash program/erase operations	$T_{JPFlash}$ SR	-	-	150	°C	

- 1) All typical values were characterised, but are not tested. Typical values are safe median values at room temperature
- 2) Under out-of-spec conditions (e.g. over-cycling) or in case of activation of WL oriented defects, the duration of erase processes may be increased by up to 50%.
- 3) Time is not dependent on program mode (5V or 3.3V).
- 4) Using 512 KByte erase commands.
- 5) Only valid when a robust EEPROM emulation algorithm is used. For more details see the Users Manual.

3.36 Package Outline

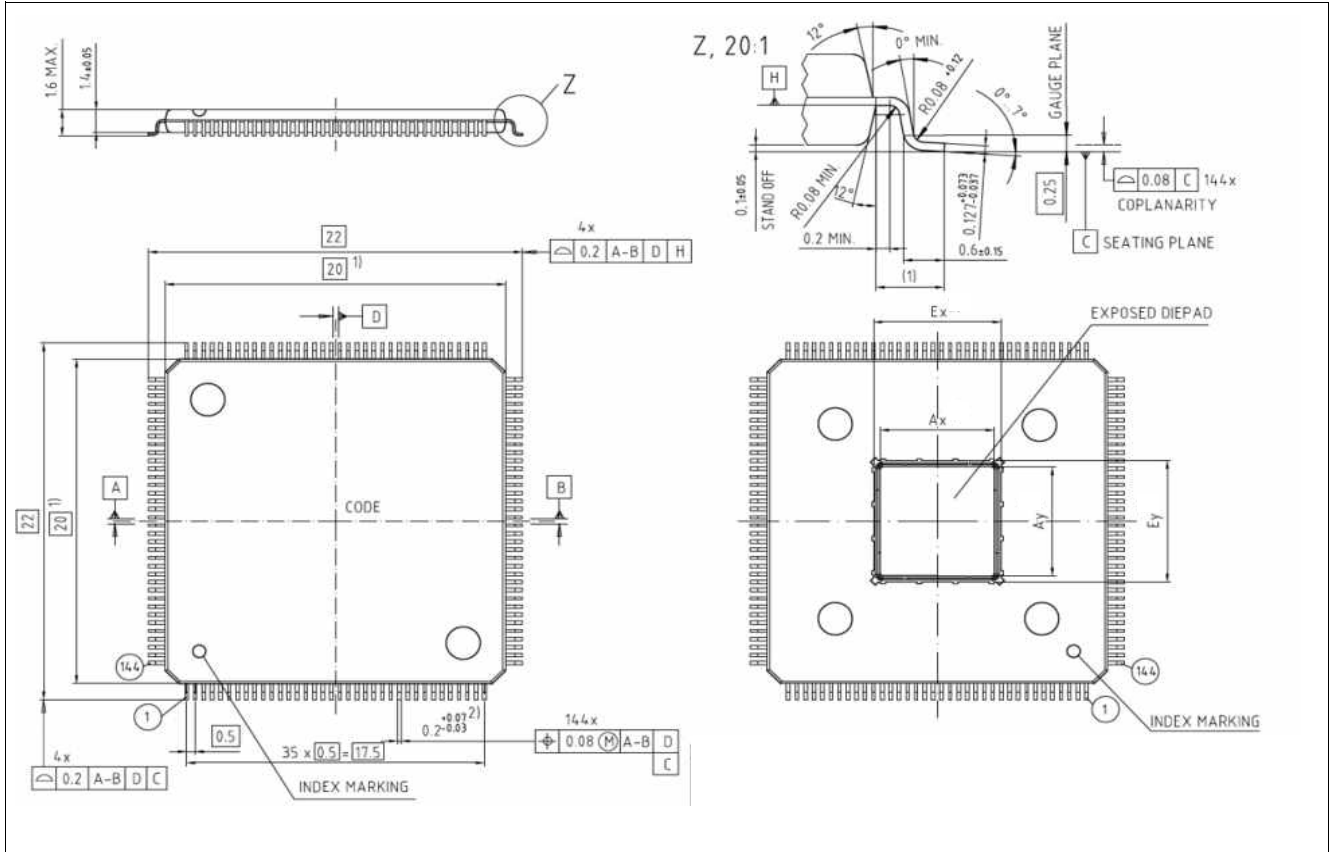

Figure 3-31 Package Outlines PG-LQFP-144-22

Table 3-104 Exposed Pad Dimensions

Ax; valid for Feature Package D and DC (nominal EPad size)	7.5 mm ± 50 μm
Ay; valid for Feature Package D and DC (nominal EPad size)	7.5 mm ± 50 μm
Ex; valid for Feature Package D and DC (solder able EPad size)	6.7 mm ± 50 μm
Ey; valid for Feature Package D and DC (solder able EPad size)	6.7 mm ± 50 μm
Ax; valid for Feature Package DA (nominal EPad size)	7.7 mm ± 50 μm
Ay; valid for Feature Package DA (nominal EPad size)	9.2 mm ± 50 μm
Ex; valid for Feature Package DA (solder able EPad size)	6.9 mm ± 50 μm
Ey; valid for Feature Package DA (solder able EPad size)	8.4 mm ± 50 μm

Note: It is recommended to use dimensions E_x and E_y for board layout considerations. Solder wetting between E_x / E_y and A_x / A_y and lead between E_x / E_y and A_x / A_y will not cause any harm.

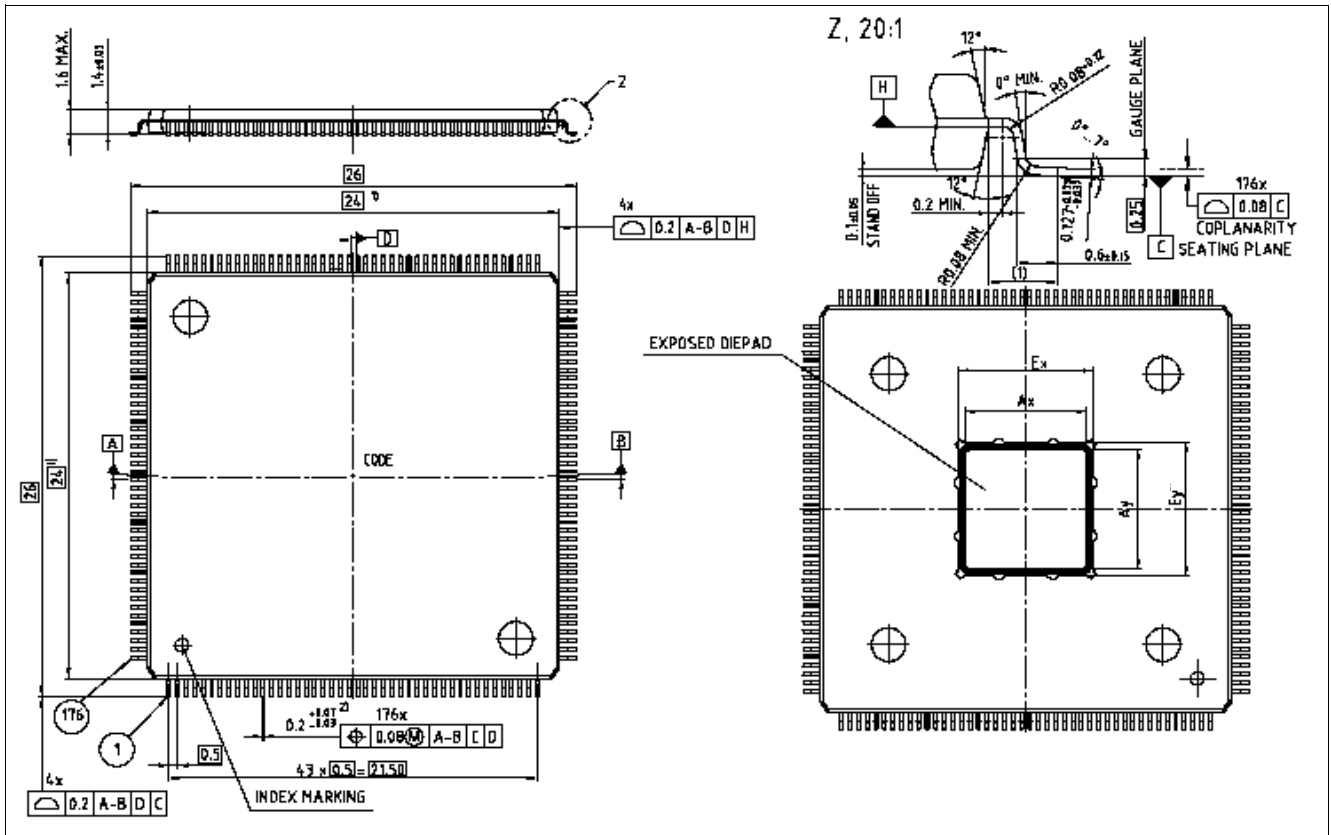
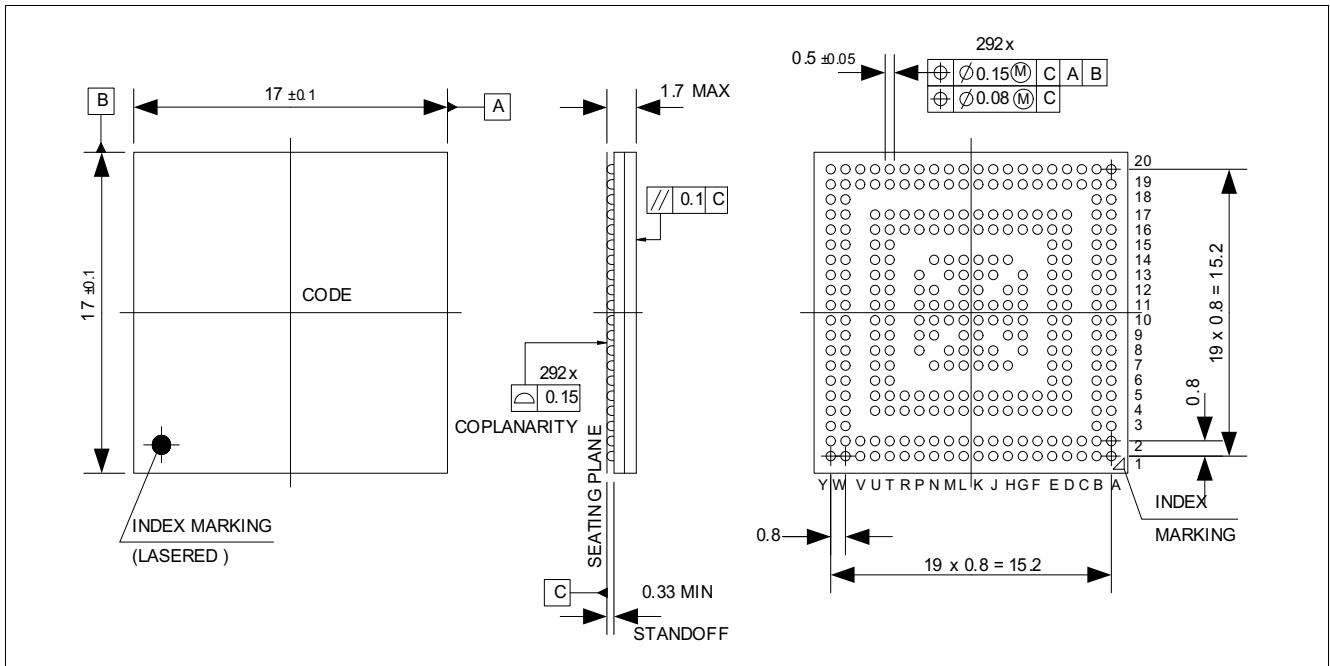

Figure 3-32 Package Outlines PG-LQFP-176-22

Table 3-105 Exposed Pad Dimensions

Ax; valid for Feature Package D and DC (nominal EPad size)	7.5 mm ± 50 μm
Ay; valid for Feature Package D and DC (nominal EPad size)	7.5 mm ± 50 μm
Ex; valid for Feature Package D and DC (solder able EPad size)	6.7 mm ± 50 μm
Ey; valid for Feature Package D and DC (solder able EPad size)	6.7 mm ± 50 μm
Ax; valid for Feature Package DA (nominal EPad size)	7.7 mm ± 50 μm
Ay; valid for Feature Package DA (nominal EPad size)	9.2 mm ± 50 μm
Ex; valid for Feature Package DA (solder able EPad size)	6.9 mm ± 50 μm
Ey; valid for Feature Package DA (solder able EPad size)	8.4 mm ± 50 μm

Note: It is recommended to use dimensions Ex and Ey for board layout considerations. Solder wetting between Ex / Ey and Ax / Ay and lead between Ex / Ey and Ax / Ay will not cause any harm.

Figure 3-33 Package Outlines PG-LFBGA-292-6

You can find all of our packages, sorts of packing and others in our Infineon Internet Page "Products": <http://www.infineon.com/products>.

3.36.1 Package Parameters

Table 3-106 Thermal Characteristics of the Package

Device	Package	RQJCT ¹⁾	RQJCB ¹⁾	RQJA	Unit	Note
TC264	PG-LQFP-144-22PG-LFBGA-292-6	13,3	3,3	18,6 ²⁾	K/W	with soldered exposed pad
TC265	PG-LQFP-176-22PG-LFBGA-292-6	11,7	3,5	19,4 ²⁾	K/W	with soldered exposed pad
TC267	PG-LFBGA-292-6	11,1	15,0	24,9 ³⁾	K/W	

1) The top and bottom thermal resistances between the case and the ambient (R_{TCAT} , R_{TCAB}) are to be combined with the thermal resistances between the junction and the case given above (R_{TJCT} , R_{TJCB}), in order to calculate the total thermal resistance between the junction and the ambient (R_{TJA}). The thermal resistances between the case and the ambient (R_{TCAT} , R_{TCAB}) depend on the external system (PCB, case) characteristics, and are under user responsibility.

The junction temperature can be calculated using the following equation: $T_J = T_A + R_{TJA} * P_D$, where the R_{TJA} is the total thermal resistance between the junction and the ambient. This total junction ambient resistance R_{TJA} can be obtained from the upper four partial thermal resistances.

Thermal resistances as measured by the 'cold plate method' (MIL SPEC-883 Method 1012.1).

2) Value is defined in accordance with JEDEC JESD51-3, JESD51-5, and JESD51-7.

3) Value is defined in accordance with JEDEC JESD51-1.

3.36.2 TC260 Carrier Tape

3.37 Quality Declarations

Table 3-108 Quality Parameters

Parameter	Symbol	Values			Unit	Note / Test Condition
		Min.	Typ.	Max.		
Operation Lifetime	t_{OP}	-	-	24500	hour	
ESD susceptibility according to Human Body Model (HBM)	V_{HBM}	-	-	2000	V	Conforming to JESD22-A114-B
ESD susceptibility of the LVDS pins	V_{HBM1}	-	-	500	V	
ESD susceptibility according to Charged Device Model (CDM)	V_{CDM}	-	-	500	V	for all other balls/pins; conforming to JESD22-C101-C
		-	-	750	V	for corner balls/pins; conforming to JESD22-C101-C
Moisture Sensitivity Level	MSL	-	-	3		Conforming to Jedec J-STD--020C for 240C

4 History

Version 1.0 is the first version of this document.

- VADC
 - Add parameter t_{WU}
 - Add parameter R_{MDU}
 - Add parameter R_{MDD}
- Calculating the 1.3 V Current Consumption
 - Add formula 3.4
 - Add formula 3.5
- Changes in table 'Master Mode timing MPRm/MP+m/MPm/LPm output pads' of QSPI/5V
 - Change max value of t_{51} from '15 ns' to '17 ns'
- EVR/Supply Monitoring
 - Change note of t_{EVRMON} from " to 'after trimming'

www.infineon.com

Published by Infineon Technologies AG