

# TARS SERIES

000828

Issue 3

## Transportation Attitude Reference System. Ruggedized Inertial Measurement Unit (IMU)

### DESCRIPTION

The Transportation Attitude Reference System (TARS-IMU) is a packaged sensor array designed to report vehicle angular rate, acceleration, and attitude data for demanding applications in industries such as heavy duty, off-highway transportation.

The TARS-IMU enables autonomous vehicle characteristics and enhances efficiency and productivity by reporting key data required to automate and monitor movements of vehicle systems and components. The sensor fusion algorithm may be customized for specific vehicle applications through on-board firmware, allowing movement data to be filtered for extraneous environment and vehicle movements.

With two sensor models for different power levels, the TARS-IMU accommodates both 5 V and 9 V to 36 V vehicle power systems. Communication is transmitted using industry standard CAN J1939 connectivity. As a standard, TARS-IMU is calibrated on aerospace-grade rate tables at the factory to provide enhanced calibration consistency between units.

### DIFFERENTIATION

- **Flexible.** On-board firmware customizes TARS-IMU to the specific vehicle for its designed application.
- **Durable.** With top-of-the-line sealing (IP67, IP69K), TARS-IMU is ruggedized to withstand harsh or heavy duty applications.
- **Convenient.** TARS-IMU may be pre-configured at the Honeywell factory for immediate installation out of the box. It may also be delivered with customizable firmware that allows manufacturers to use a single part number across vehicles and applications.

### VALUE TO CUSTOMERS

- Designed to allow vehicle manufacturers and end users to increase efficiency with the automation of repetitive movements and complex tasks
- Enables precise movement, actuation, and guidance over severe terrain and vehicle grades
- Enhances safety through monitoring and guidance capabilities to promote the productivity of operators

### POTENTIAL APPLICATIONS

- Equipment control
- Linear position
- Linkage tracking
- Bucket control
- Work monitoring
- Vehicle stability control
- Operator assisted control
- Performance and output control



### FEATURES

- High performance IMU reports vehicle angular rate, acceleration and inclination data (6 degrees of freedom, see Figure 1)
- Ruggedized PBT thermoplastic housing design for many demanding applications and environments (IP67 and IP69K certified)
- Advanced filtering of raw sensor data to minimize unwanted noise and vibrations promotes positioning accuracy
- Supports 5 V and 9 V to 36 V vehicle power systems
- Operating temperature of -40°C to 85°C [-40°F to 185°F]
- Reduced power consumption
- Small form-factor
- Optional metal guard for added protection



TARS-IMU joins Honeywell's venerated sensor portfolio, and adding to the ever-increasing connected and intelligence driven capabilities that Honeywell offers. TARS-IMU is built to survive the demanding applications in industries like off-highway transportation and beyond.

**Honeywell**

# TRANSPORTATION ATTITUDE REFERENCE SYSTEM, TARS SERIES

FIGURE 1. SIX DEGREES OF FREEDOM

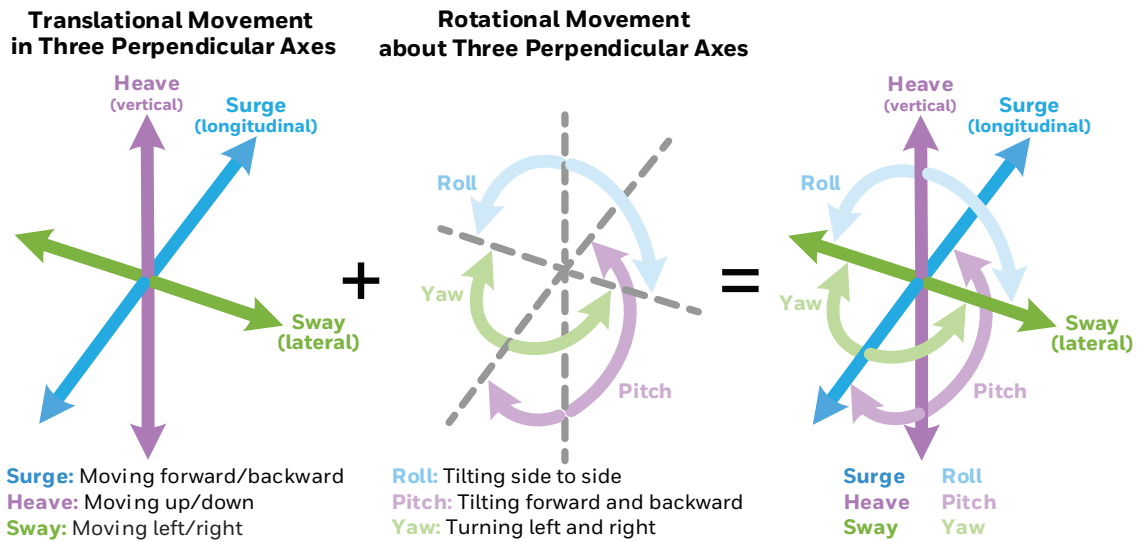

TABLE 1. SENSOR SPECIFICATIONS

CHARACTERISTIC	MIN.	TYP.	MAX.	UNIT
<b>Gyroscope 3 axis performance</b>				
Range <sup>1</sup>	-245	-	+245	deg/s
Resolution	-	8.75	-	mdps
In-run bias stability	-	1	-	mdps
Noise density	-	4	-	mdps/√Hz
Offset (0°C to 50°C)	-	±0.8	-	deg/s
Offset (-40°C to 85°C)	-	±1.6	-	deg/s
<b>Accelerometer 3 axis performance</b>				
Range <sup>1</sup>	-78.48	-	+78.48	m/s <sup>2</sup>
Resolution <sup>2</sup>	-	0.01	-	m/s <sup>2</sup>
In-run bias stability	-	50	-	μg
Noise density	-	65	-	μg/√Hz
Offset (0°C to 50°C)	-	±0.05	-	m/s <sup>2</sup>
Offset (-40°C to 85°C)	-	±0.15	-	m/s <sup>2</sup>
<b>Inclination (pitch and roll)</b>				
Range <sup>1</sup>	-85	-	+85	deg
Resolution	-	0.014	-	deg
Static error (0°C to 50°C)	-	±0.3	-	deg
Static error (-40°C to 85°C)	-	±0.9	-	deg
Translational acceleration error	-	±0.5	-	deg
Centripetal acceleration error	-	±0.5	-	deg

<sup>1</sup> Sensors are calibrated in the following ranges: ±60 deg/s for angular rate, ±9.80665 m/s<sup>2</sup> for acceleration, and ±30 deg for pitch and roll. Calibrated ranges may be extended to maximums shown with deviation to performance specifications.

- Angular rate outputs per PGN 61482; Z-down convention required by J1939.
- Acceleration outputs per PGN 61485; Z-up convention required by J1939.
- Pitch and roll outputs per PGN 61481; Z-down convention required by J1939.

<sup>2</sup> Accelerometer resolution is limited by the J1939 protocol.

# TRANSPORTATION ATTITUDE REFERENCE SYSTEM, TARS SERIES

**TABLE 2. ELECTRICAL SPECIFICATIONS • TARS-LCASS**

CHARACTERISTIC	MIN.	NOMINAL	MAX.	UNIT
Supply voltage	4.5	5	5.5	V
Supply current	–	–	100	mA
Start-up time	500	–	2000	ms
Short circuit protection	ISO 16750-2: 2012 – CAN output shorted to supply voltage or ground without damage			
Open circuit protection	ISO 16750-2: 2012 – Single-line and multiple-line interruption			
Power interruption	ISO 11783-5: 2009 – 10 ms interruption, 100 ms apart; no resets or loss of data in volatile memory			
Reset response	ISO 16750-2: 2012 – Automatic recovery after voltage dropout			

**CAN output characteristics per SAE J1939**

CHARACTERISTIC	MIN.	NOMINAL	MAX.	UNIT
Baud rate	125	250 <sup>1</sup>	500	kbps
Signal update rate	–	–	100 <sup>2</sup>	Hz

<sup>1</sup> Factory default setting is 250 kbps.

<sup>2</sup> Factory default setting is 100 Hz.

**TABLE 3. ELECTRICAL SPECIFICATIONS • TARS-HCASS**

CHARACTERISTIC	MIN.	NOMINAL	MAX.	UNIT
Supply voltage	9	12/24	36	V
Supply current	–	–	100	mA
Reverse voltage	–	–	-36	V
Overvoltage	–	–	36	V
Start-up time	500	–	2000	ms
Short circuit protection	ISO 16750-2: 2012 – CAN output shorted to supply voltage or ground without damage			
Open circuit protection	ISO 16750-2: 2012 – Single-line and multiple-line interruption			
Power interruption	ISO 11783-5: 2009 – 10 ms interruption, 100 ms apart; no resets or loss of data in volatile memory			
Reset response	ISO 16750-2: 2012 – Automatic recovery after voltage dropout			
Power line test pulse 1	ISO 7637-2: 2004 AMD1: 2008 / 12 and 24 V system			
Power line test pulse 2a	ISO 7637-2: 2004 AMD1: 2008 / 12 and 24 V system			
Power line test pulse 2b	ISO 7637-2: 2004 AMD1: 2008 / 12 and 24 V system			
Power line test pulses 3a and 3b	ISO 7637-2: 2004 AMD1: 2008 / 12 and 24 V system			
Load dump - suppressed	ISO 16750-2: 2012 / 12 and 24 V system			

**CAN output characteristics per SAE J1939**

CHARACTERISTIC	MIN.	NOMINAL	MAX.	UNIT
Baud rate	125	250 <sup>1</sup>	500	kbps
Signal update rate	–	–	100 <sup>2</sup>	Hz

<sup>1</sup> Factory default setting is 250 kbps.

<sup>2</sup> Factory default setting is 100 Hz.

**TABLE 4. EMC SPECIFICATIONS**

CHARACTERISTIC	STANDARD	TEST LEVEL, FREQUENCY
Radiated immunity	ISO 11452-2: 2019	125 V/m, 400 MHz to 2.5 GHz
Bulk current injection	ISO 11452-4: 2011	125 mA, 1 MHz to 400 MHz
Radiated emission	ISO 13766-1: 2018	30 MHz to 1 GHz
I/O line coupled transients	ISO 7637-3: 2016	test pulse a and test pulse b (-80 V, +80 V)
ESD handling	ISO 10605: 2008 AMD1: 2014	direct ±8 kV, air ±15 kV
ESD operational	ISO 10605: 2008 AMD1: 2014	direct ±8 kV, air ±15 kV

# TRANSPORTATION ATTITUDE REFERENCE SYSTEM, TARS SERIES

**TABLE 5. INSTALLATION SPECIFICATIONS**

CHARACTERISTIC	PARAMETER
Mating connector	AMPSEAL 16™ Series: 776487-1 for 18-16 AWG conductors or 776524-1 for 20-18 AWG conductors
CAN termination	120 ohm termination resistor, not included in TARS-IMU unit
Weight	170 g approx.
Mounting direction	+Z
Mounting bolt	M8, installation torque 20 Nm ±2 Nm

**TABLE 6. ENVIRONMENTAL SPECIFICATIONS<sup>1</sup>**

CHARACTERISTIC	PARAMETER
Operating temperature	-40°C to 85°C [40°F to 185°F]
Storage temperature <sup>2</sup>	-40°C to 105°C [40°F to 221°F]
Housing	PBT thermoplastic
Random vibration	10 hours at 25 Grms per MIL-STD-810, Method 514.7, Procedure I, Annex D, Category 20, 5 Hz to 500 Hz (flat spectrum)
Mechanical shock	50 g 11 ms half-sine, 3 each direction, 18 total, pulse per MIL-STD-202, Method 213
Chemical compatibility	diesel fuel, hydraulic oil, ethylene glycol, motor oil, brake fluid, urea nitrogen, liquid lime, NPK fertilizer, ammonium hydroxide, alkaline degreaser, transmission oil, power steering fluid, and axle oil
Moisture resistance	per MIL-STD-202, Method 106 (10 cycles, 24 hours/cycle)
Thermal shock	250 cycles, -40°C to 85°C, 73 min dwell
Salt spray	5 % salt solution, 96 hours
Ingress protection	IP67, IP69K (DIN40050-1993) with mating connector installed
RoHS	compliant
REACH	compliant
UV rating	housing material meets outdoor suitability requirements per UL746C F1 rating

<sup>1</sup> For environmental conditions not covered by product specification, consult with Honeywell Engineering.

<sup>2</sup> In installed condition; otherwise, maximum storage temperature is 85°C [185°F].

**TABLE 7. ORDER GUIDE**

PART NUMBER	DESCRIPTION
TARS-LCASS	TARS Series Inertial Measurement Unit, 5 V, CAN protocol, AMPSEAL 16 termination, standard MEMS chip generation/performance
TARS-HCASS	TARS Series Inertial Measurement Unit, 9 V to 36 V, CAN protocol, AMPSEAL 16 termination, standard MEMS chip generation/performance

**FIGURE 2. PRODUCT NOMENCLATURE**

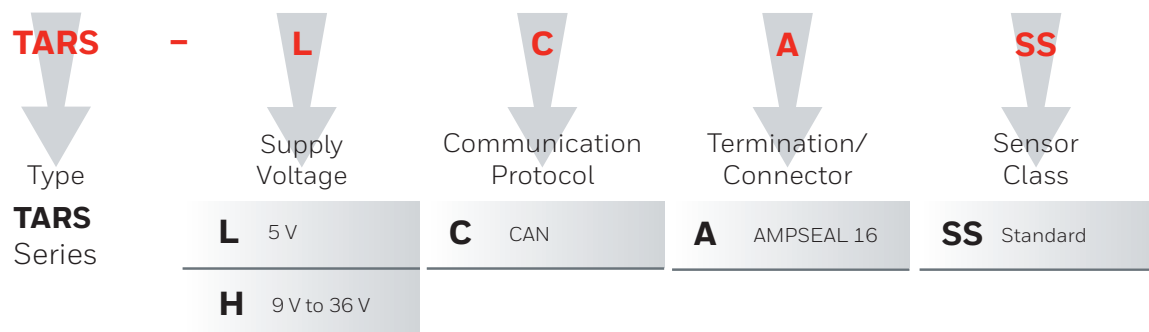

# TRANSPORTATION ATTITUDE REFERENCE SYSTEM, TARS SERIES

FIGURE 3. BODY DIMENSIONS (FOR REFERENCE ONLY: mm [in])

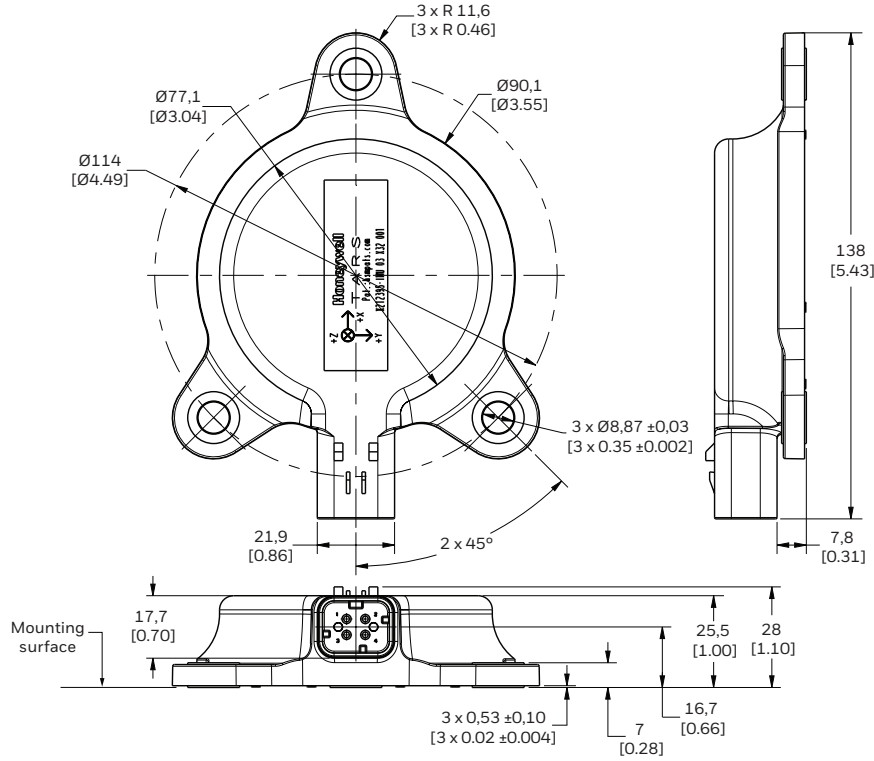

FIGURE 4. MOUNTING HOLES DIMENSIONS (FOR REFERENCE ONLY: mm [in])

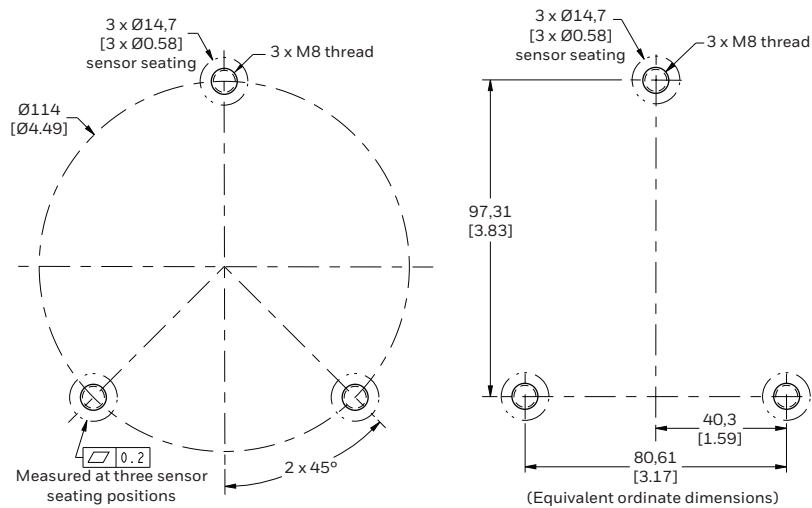

FIGURE 5. PINOUT

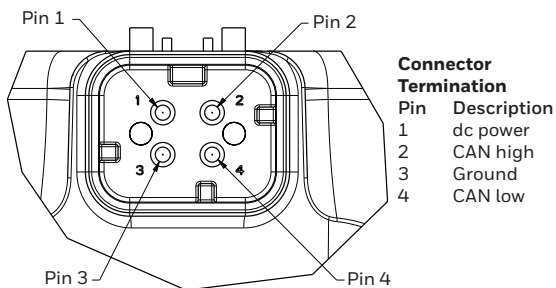
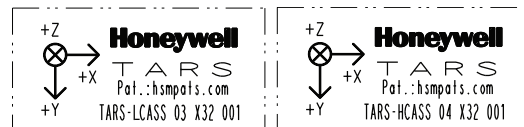

FIGURE 6. MARKING INFORMATION



**Where**  
**03, 04** Product configuration code: 03 (LCASS) or 04 (HCASS)  
**X32** Date code, where:  
**X:** Year code for 2016, Y for 2017, Z for 2018, A for 2019, etc.  
**32:** Week of final test  
**001** is a consecutive number, different for each product

**NOTE:** The axis origin triad marked on the housing defines a Z-Down axis system for pitch and roll output, and the sign convention is in accordance to the right-hand rule.

## ADDITIONAL MATERIALS

The following associated literature is available at [sensing.honeywell.com](http://sensing.honeywell.com):

- Product range guide
- Application information
- CAD models
- Product images

## WARRANTY/REMEDY

Honeywell warrants goods of its manufacture as being free of defective materials and faulty workmanship during the applicable warranty period. Honeywell's standard product warranty applies unless agreed to otherwise by Honeywell in writing; please refer to your order acknowledgment or consult your local sales office for specific warranty details. If warranted goods are returned to Honeywell during the period of coverage, Honeywell will repair or replace, at its option, without charge those items that Honeywell, in its sole discretion, finds defective. **The foregoing is buyer's sole remedy and is in lieu of all other warranties, expressed or implied, including those of merchantability and fitness for a particular purpose. In no event shall Honeywell be liable for consequential, special, or indirect damages.**

While Honeywell may provide application assistance personally, through our literature and the Honeywell web site, it is buyer's sole responsibility to determine the suitability of the product in the application.

Specifications may change without notice. The information we supply is believed to be accurate and reliable as of this writing. However, Honeywell assumes no responsibility for its use.

## FOR MORE INFORMATION

Honeywell Sensing and Internet of Things services its customers through a worldwide network of sales offices and distributors. For application assistance, current specifications, pricing or the nearest Authorized Distributor, visit [sensing.honeywell.com](http://sensing.honeywell.com) or call:

Asia Pacific	+65 6355-2828
Europe	+44 1698 481481
USA/Canada	+1-302-613-4491

AMPSEAL 16™ is a trademark of Tyco Electronics Services GMBH.

## Honeywell Sensing and Internet of Things

9680 Old Bailes Road  
Fort Mill, SC 29707  
[honeywell.com](http://honeywell.com)

000828-3-EN | 3 | 09/19  
©2019 Honeywell International Inc. All rights reserved.

## WARNING PERSONAL INJURY

DO NOT USE these products as safety or emergency stop devices or in any other application where failure of the product could result in personal injury.

**Failure to comply with these instructions could result in death or serious injury.**

## WARNING MISUSE OF DOCUMENTATION

- The information presented in this product sheet is for reference only. Do not use this document as a product installation guide.
- Complete installation, operation, and maintenance information is provided in the instructions supplied with each product.

**Failure to comply with these instructions could result in death or serious injury.**

**Honeywell**