



TAI-SAW TECHNOLOGY CO., LTD.

No. 3, Industrial 2nd Rd., Ping-Chen Industrial District,
Taoyuan, 324, Taiwan, R.O.C.

TEL: 886-3-4690038 FAX: 886-3-4697532

E-mail: tstsales@mail.taisaw.com Web: www.taisaw.com

Product Specifications Approval Sheet

Product Name: SAW Filter 1745 MHz BW 70 MHz SMD 3.0X3.0 mm

TST Parts No.: TA2732AA3112

Customer Parts No.: _____

Company: _____
Division: _____
Approved by : _____
Date: _____

Checked by: _____ Sam Lin *Sam Lin*

Approval by: _____ Andy Yu *Andy Yu*

Date: _____ 2020/12/25

1. Customer signed back is required before TST can proceed with sample build and receive orders.
2. Orders received without customer signed back will be regarded as agreement on the specifications.
3. Any specifications changes must be approved upon by both parties and a new revision of specifications shall be released to reflect the changes



TAI-SAW TECHNOLOGY CO., LTD.

No. 3, Industrial 2nd Rd., Ping-Chen Industrial District,
Taoyuan, 324, Taiwan, R.O.C.

TEL: 886-3-4690038 FAX: 886-3-4697532

E-mail: tstsales@mail.taisaw.com Web: www.taisaw.com

SAW Filter 1745 MHz BW 70 MHz SMD 3.0X3.0 mm

MODEL NO.:TA2732AA3112

REV. NO.:1.0

A. MAXIMUM RATING:

1. Input Power Level: 16 dBm
2. DC Voltage : 0 V
3. Operating Temperature: -40°C to +85°C
4. Storage Temperature: -40°C to +85°C
5. Moisture Sensitive Level: MSL 1

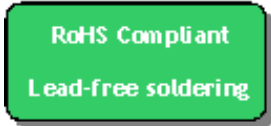

Electrostatic Sensitive Device (ESD)

B. ELECTRICAL CHARACTERISTICS:

Terminating source impedance (single) : $Z_s = 50 \Omega$

Terminating load impedance (single) : $Z_L = 50 \Omega$

Item	Unit	Min.	Type.	Max.
Center Frequency	MHz	-	1745	-
Insertion Loss (1710 ~ 1780 MHz)	dB	-	2.8	3.5
Amplitude ripple (1710 ~ 1780 MHz)	dB	-	0.6	1.5
Return Loss (1710 ~ 1780 MHz)	dB	8	11	-
Attenuation				
10 ~ 1320 MHz	dB	30	43	-
1995 ~ 2200 MHz	dB	25	29	-
2200 ~ 3000 MHz	dB	25	33	-
Temperature Coefficient of Frequency	ppm/C°	-	-36	-

C. TEST CIRCUIT:

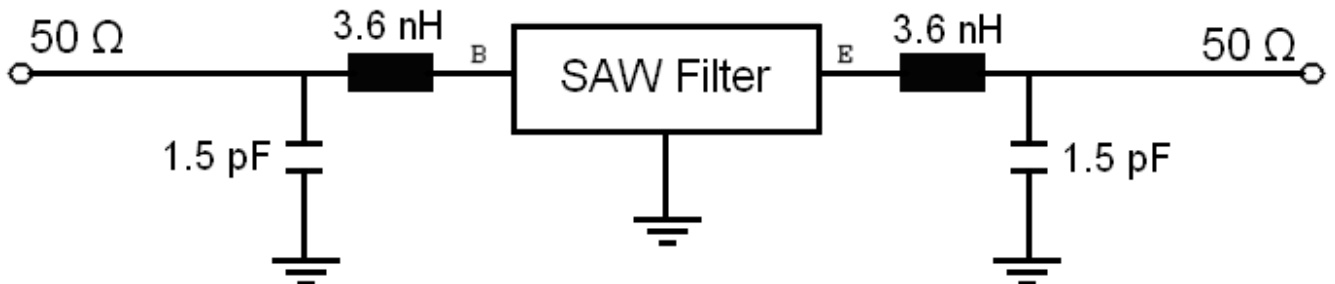

D. OUTLINE DRAWING:

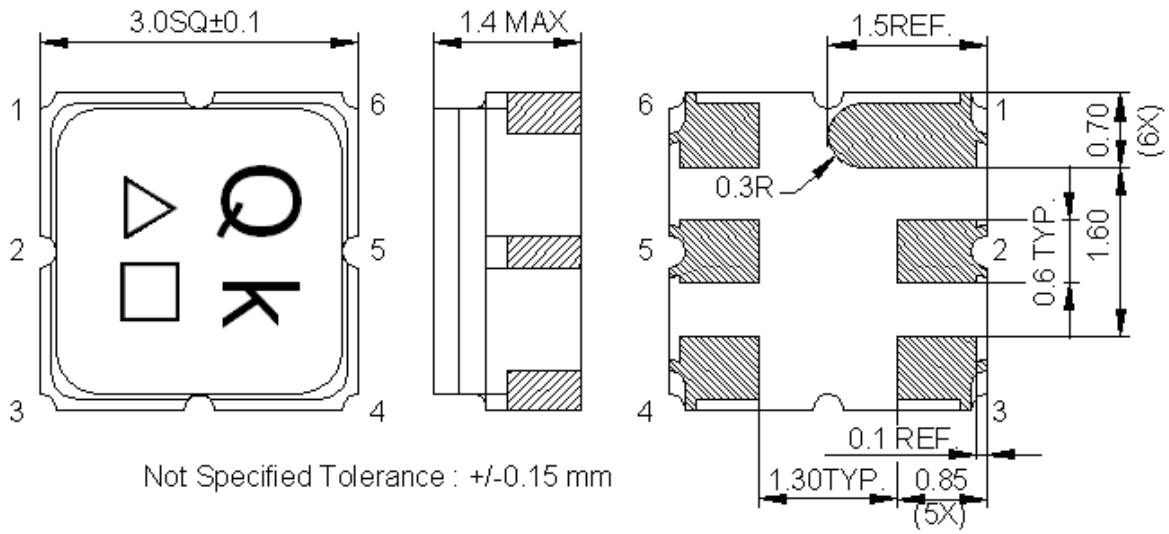

2: Input
5: Output
Other: Ground
Unit: mm

△ : Year Code (2009->9, 2010->0, ..., 2018->8)

□ : Date Code (Follow the table from planner each year)

WK01	WK02	WK03	WK04	WK05	WK06	WK07	WK08	WK09	WK10	WK11	WK12	WK13
A	B	C	D	E	F	G	H	I	J	K	L	M
WK14	WK15	WK16	WK17	WK18	WK19	WK20	WK21	WK22	WK23	WK24	WK25	WK26
N	O	P	Q	R	S	T	U	V	W	X	Y	Z
WK27	WK28	WK29	WK30	WK31	WK32	WK33	WK34	WK35	WK36	WK37	WK38	WK39
a	b	c	d	e	f	g	h	i	j	k	l	m
WK40	WK41	WK42	WK43	WK44	WK45	WK46	WK47	WK48	WK49	WK50	WK51	WK52
n	o	p	q	r	s	t	u	v	w	x	y	z

E. Frequency Characteristics:

Span 800 MHz

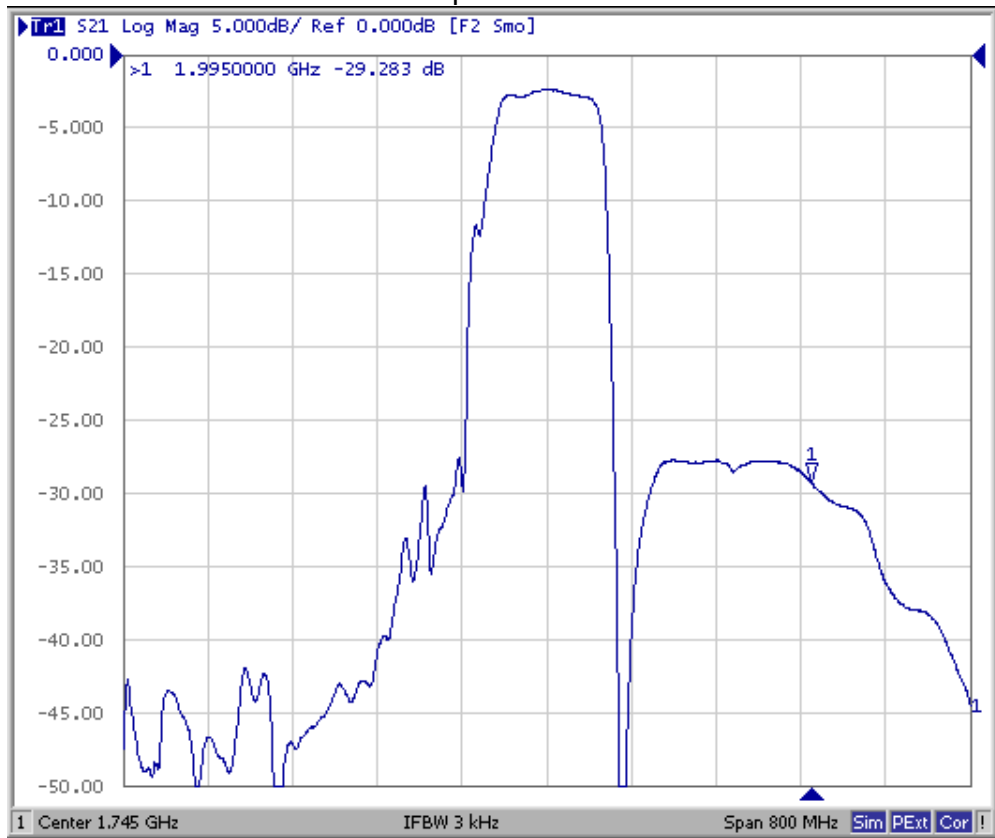

Span 3000 MHz

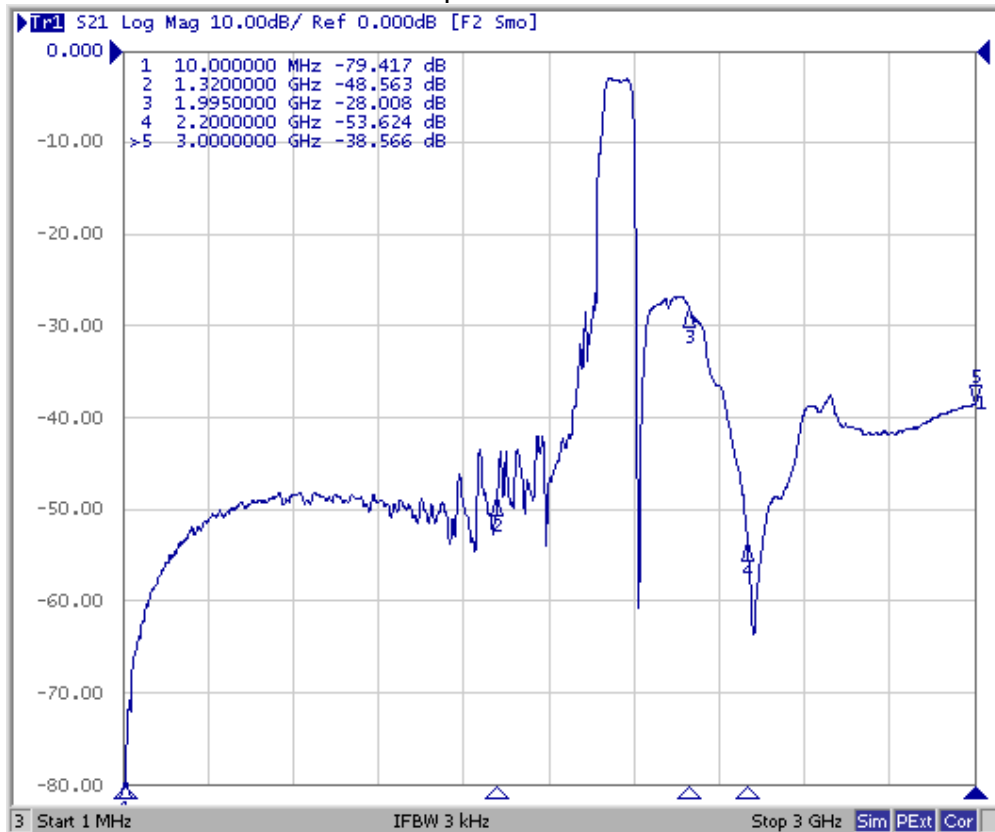

Span 200 MHz

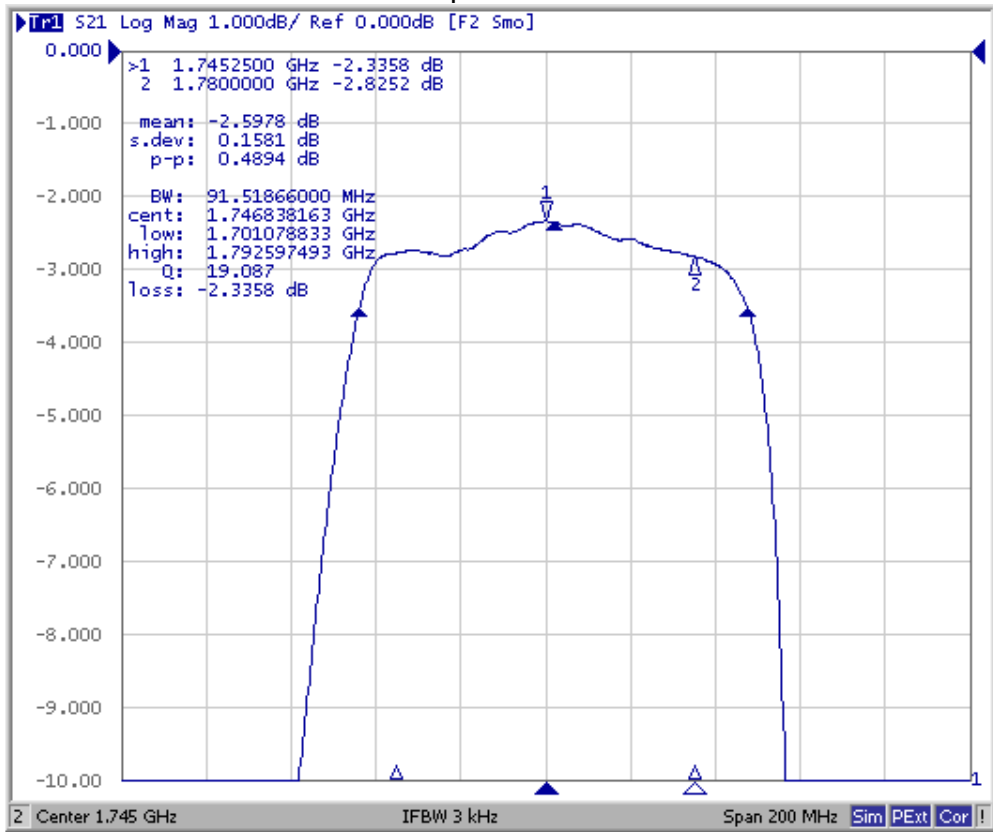

Reflection Characteristic

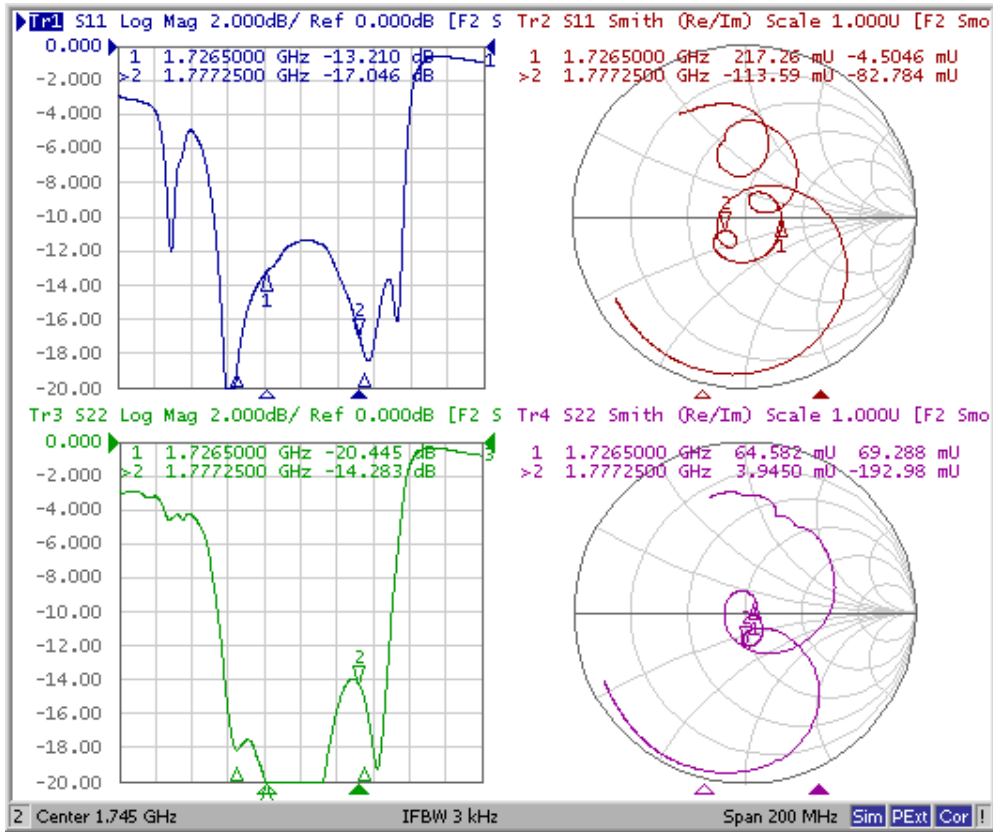

F. PCB FOOTPRINT:

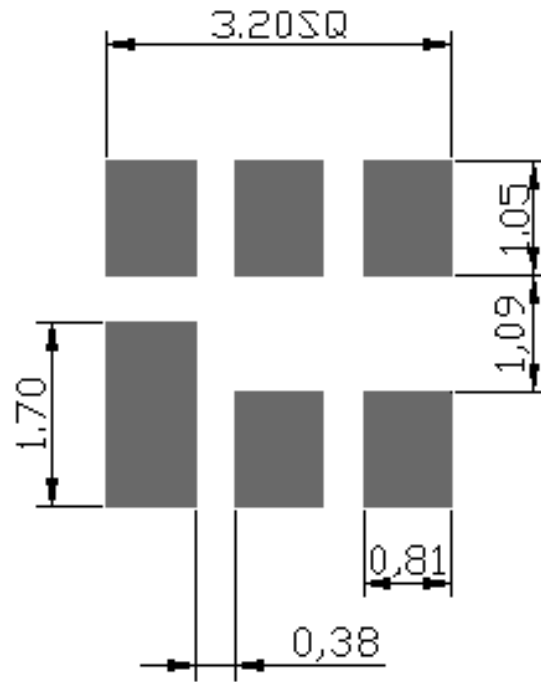

G. PACKING:

1. REEL DIMENSION

(Please refer to FR-75D10 for packing quantity)

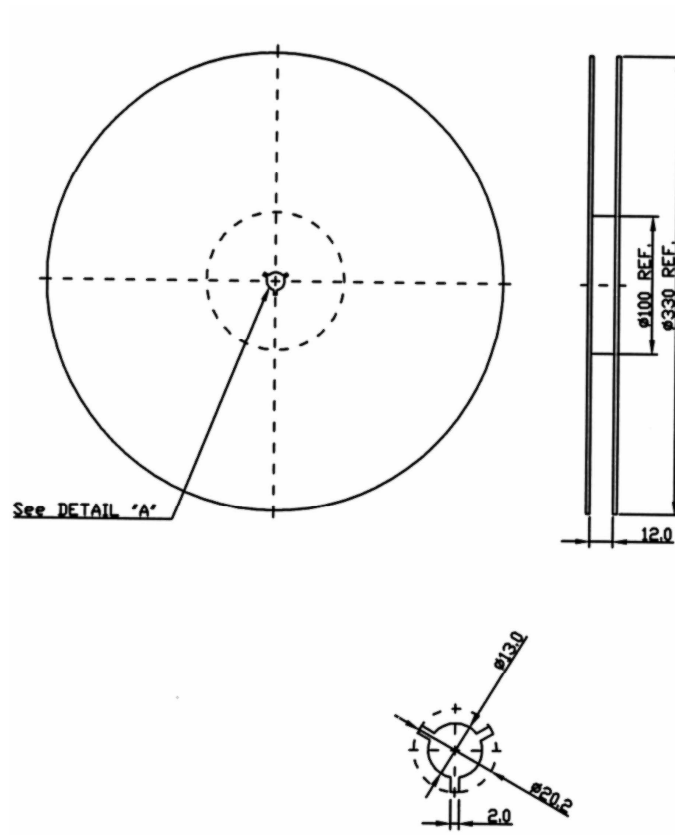

2. TAPE DIMENSION

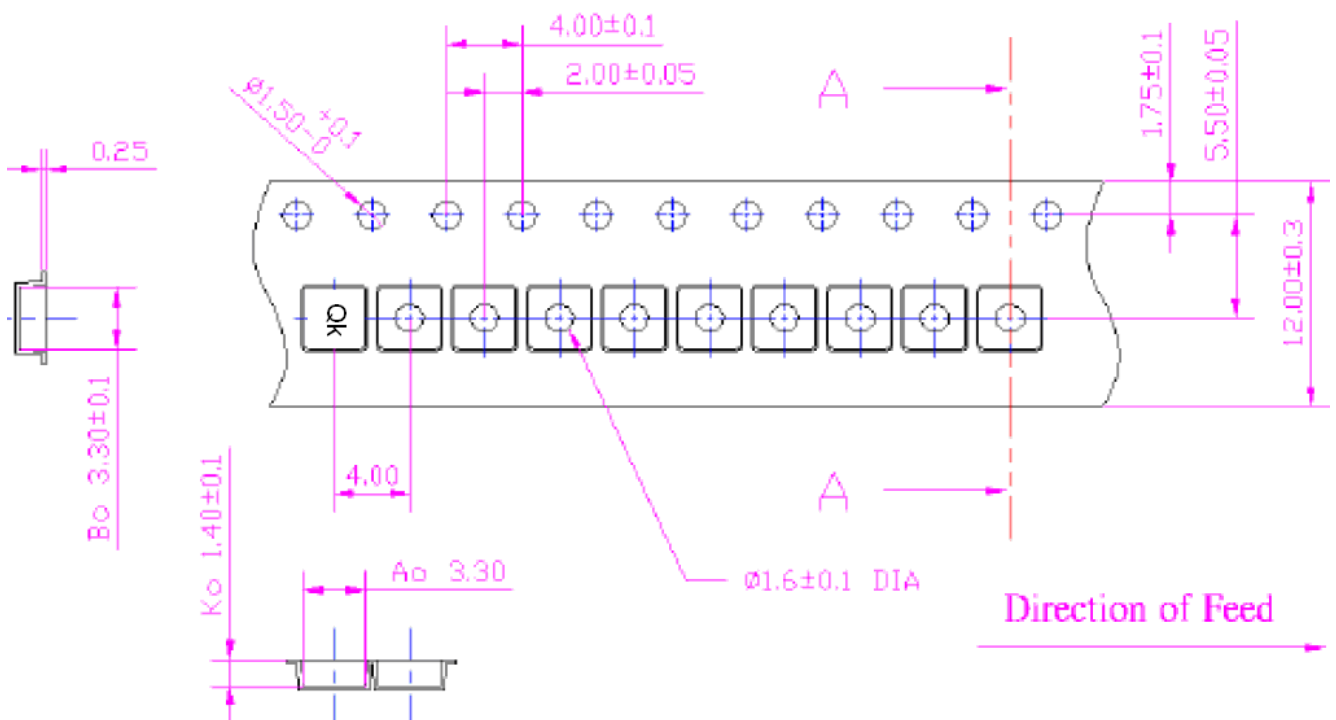

H. RECOMMENDED REFLOW PROFILE :

1. Preheating shall be fixed at 150~180°C for 60~90 seconds.
2. Ascending time to preheating temperature 150°C shall be 30 seconds min.
3. Heating shall be fixed at 220°C for 50~80 seconds and at 260°C +0/-5°C peak (20~40sec).
4. Time: 2 times.

