

KEMET Part Number: T520T227M004ATE030
(TEPSLB30G227M(30)8RKT)

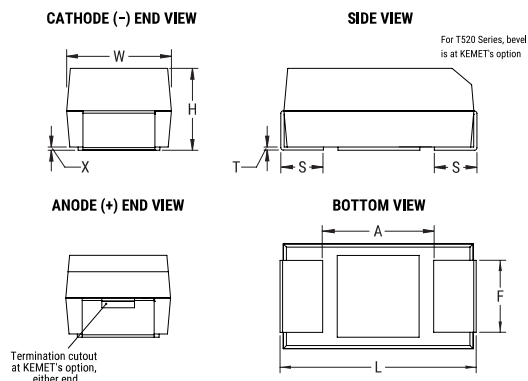

T520, Tantalum, Polymer Tantalum, 220 uF, 20%, 4 VDC, SMD, Polymer, Molded, Low Profile/ESR, NonCombustible, 30 mOhms, 3528, Height Max = 1.2mm



| Dimensions | |
|------------|----------------|
| Footprint | 3528 |
| L | 3.5mm +/-0.2mm |
| W | 2.8mm +/-0.2mm |
| H | 1.1mm +/-0.1mm |
| T | 0.13mm REF |
| S | 0.8mm +/-0.3mm |
| F | 2.2mm +/-0.1mm |
| A | 1.9mm MIN |
| X | 0.05mm REF |

| Packaging Specifications | |
|--------------------------|------------|
| Packaging: | T&R, 178mm |
| Packaging Quantity: | 3000 |

| General Information | |
|---------------------|---|
| Series: | T520 |
| Dielectric: | Polymer Tantalum |
| Style: | SMD Chip |
| Description: | SMD, Polymer, Molded, Low Profile/ESR, NonCombustible |
| Features: | Low ESR |
| RoHS: | Yes |
| Termination: | Tin |
| AEC-Q200: | No |
| Component Weight: | 54.84 mg |
| Shelf Life: | 52 Weeks |
| MSL: | 3 |

| Specifications | |
|------------------------|--|
| Capacitance: | 220 uF |
| Capacitance Tolerance: | 20% |
| Voltage DC: | 4 VDC (105C) |
| Temperature Range: | -55/+105°C |
| Rated Temperature: | 105°C |
| Humidity: | 60C, 90% RH, 500 Hours, No Load |
| Dissipation Factor: | 10% 120Hz 25C |
| Failure Rate: | N/A |
| Resistance: | 30 mOhms (100kHz 25C) |
| Ripple Current: | 1870 mA (rms, 100kHz 45C), 1309 mA (rms, 85C), 467.5 mA (rms, 105C) |
| Leakage Current: | 176 uA (5min 25°C) |

Statements of suitability for certain applications are based on our knowledge of typical operating conditions for such applications, but are not intended to constitute - and we specifically disclaim - any warranty concerning suitability for a specific customer application or use. This Information is intended for use only by customers who have the requisite experience and capability to determine the correct products for their application. Any technical advice inferred from this Information or otherwise provided by us with reference to the use of our products is given gratis, and we assume no obligation or liability for the advice given or results obtained.

