

Rad-Hard P-channel 100 V, 34 A Power MOSFET

Datasheet - production data

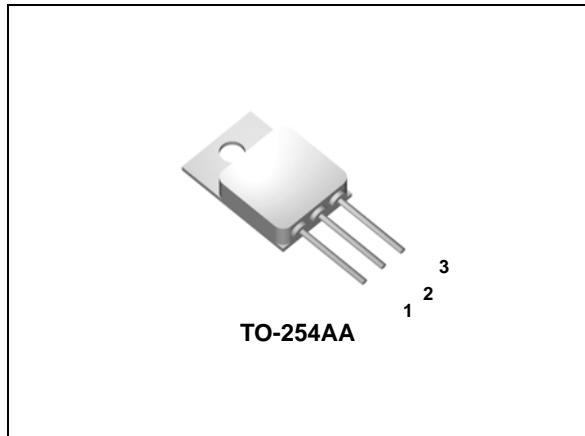
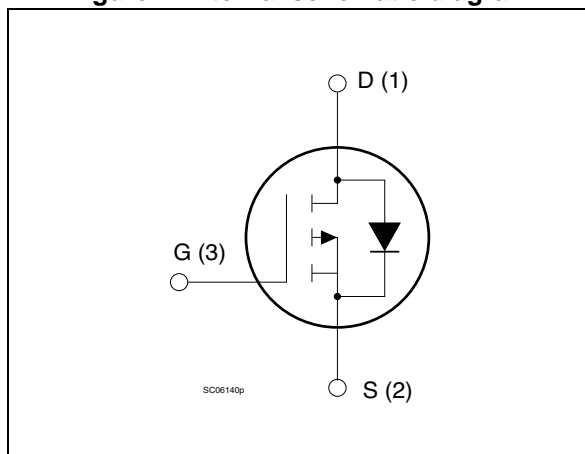

Figure 1. Internal schematic diagram



Features

V_{BDSS}	I_D	$R_{DS(on)}$	Q_g
100 V	34 A	0.060 Ohm	162 nC

- Fast switching
- 100% avalanche tested
- Hermetic package
- 100 krad TID
- SEE radiation hardened

Applications

- Satellite
- High reliability

Description

This P-channel Power MOSFET is developed with STMicroelectronics unique STripFET™ process. It has specifically been designed to sustain high TID and provide immunity to heavy ion effects.

This Power MOSFET is fully ESCC qualified.

Table 1. Device summary

Part number	ESCC part number	Quality level	Package	Lead finish	Mass (g)	Temp. range	EPPL
STRH40P10HY1	-	Engineering model	TO-254AA	Gold	10	-55 to 150°C	-
STRH40P10HYG	5205/025/01	ESCC flight		Solder Dip			Target
STRH40P10HYT	5205/025/02						-

Note: Contact ST sales office for information about the specific conditions for product in die form and for other packages.

Contents

1	Electrical ratings	3
2	Electrical characteristics	5
3	Radiation characteristics	7
4	Electrical characteristics (curves)	10
5	Test circuits	12
6	Package mechanical data	14
7	Order codes	16
8	Revision history	17

1 Electrical ratings

($T_C = 25\text{ °C}$ unless otherwise specified).

Note: For the P-channel MOSFET actual polarity of voltages and current has to be reversed.

Table 2. Absolute maximum ratings (pre-irradiation)

Symbol	Parameter	Value	Unit
$V_{DS}^{(1)}$	Drain-source voltage ($V_{GS} = 0$)	100	V
$V_{GS}^{(2)}$	Gate-source voltage	± 20	V
$I_D^{(3)}$	Drain current (continuous)	34	A
$I_D^{(3)}$	Drain current (continuous) at $T_C = 100\text{ °C}$	21	A
$I_{DM}^{(4)}$	Drain current (pulsed)	136	A
$P_{TOT}^{(3)}$	Total dissipation	176	W
$dv/dt^{(5)}$	Peak diode recovery voltage slope	2.5	V/ns
T_{stg}	Storage temperature	- 55 to 150	$^{\circ}\text{C}$
T_J	Operating junction temperature		$^{\circ}\text{C}$

1. This rating is guaranteed @ $T_J \geq 25\text{ °C}$ (see [Figure 10: Normalized \$BV_{DSS}\$ vs temperature](#)).
2. This value is guaranteed over the full range of temperature.
3. Rated according to the $R_{thj-case} + R_{thc-s}$.
4. Pulse width limited by safe operating area.
5. $I_{SD} \leq 40\text{ A}$, $di/dt \leq 100\text{ A}/\mu\text{s}$, $V_{DD} = 80\% V_{(BR)DSS}$.

Table 3. Thermal data

Symbol	Parameter	Value	Unit
$R_{thj-case}$	Thermal resistance junction-case max	0.71	$^{\circ}\text{C}/\text{W}$
R_{thc-s}	Case-to-sink typ	0.21	$^{\circ}\text{C}/\text{W}$

Table 4. Avalanche characteristics

Symbol	Parameter	Value	Unit
I_{AR}	Avalanche current, repetitive or not-repetitive (pulse width limited by T_J max)	17	A
$E_{AS}^{(1)}$	Single pulse avalanche energy (starting $T_J=25$ °C, $I_D=17$ A, $V_{DD}=50$ V)	1133	mJ
E_{AS}	Single pulse avalanche energy (starting $T_J=110$ °C, $I_D=17$ A, $V_{DD}=50$ V)	332	mJ
E_{AR}	Repetitive avalanche ($V_{dd}=50$ V, $I_{AR}=24$ A, $f=100$ KHz, $T_J=25$ °C, duty cycle = 10%)	25	mJ
	Repetitive avalanche ($V_{dd}=50$ V, $I_{AR}=17$ A, $f=100$ KHz, $T_J=110$ °C, duty cycle = 10%)	8	

1. Maximum rating value.

2 Electrical characteristics

($T_C = 25\text{ °C}$ unless otherwise specified).

Note: For the P-channel MOSFET actual polarity of voltages and current has to be reversed.

Pre-irradiation

Table 5. Pre-irradiation on/off states

Symbol	Parameter	Test conditions	Min.	Typ.	Max.	Unit
I_{DSS}	Zero gate voltage drain current ($V_{GS} = 0$)	80% BV_{DSS}			10	μA
I_{GSS}	Gate body leakage current ($V_{DS} = 0$)	$V_{GS} = 20\text{ V}$ $V_{GS} = -20\text{ V}$	-100		100	nA nA
$BV_{DSS}^{(1)}$	Drain-to-source breakdown voltage	$V_{GS} = 0, I_D = 1\text{ mA}$	100			V
$V_{GS(th)}$	Gate threshold voltage	$V_{DS} = V_{GS}, I_D = 1\text{ mA}$	2		4.5	V
$R_{DS(on)}$	Static drain-source on-resistance	$V_{GS} = 12\text{ V}; I_D = 17\text{ A}$		0.060	0.075	Ω

1. This rating is guaranteed @ $T_J \geq 25\text{ °C}$ (see [Figure 10: Normalized \$BV_{DSS}\$ vs temperature](#)).

Table 6. Pre-irradiation dynamic

Symbol	Parameter	Test conditions	Min.	Typ.	Max.	Unit
C_{iss} $C_{oss}^{(1)}$ C_{rss}	Input capacitance Output capacitance Reverse transfer capacitance	$V_{GS} = 0, V_{DS} = 25\text{ V},$ $f=1\text{ MHz}$	3710 510 204	4640 635 255	5570 760 306	pF pF pF
Q_g Q_{gs} Q_{gd}	Total gate charge Gate-to-source charge Gate-to-drain ("Miller") charge	$V_{DD} = 50\text{ V}, I_D = 34\text{ A},$ $V_{GS}=12\text{ V}$	130 14 32	162 18 40	194 22 48	nC nC nC
$R_G^{(1)}$	Gate input resistance	$f=1\text{MHz}$ gate DC bias=0 test signal level=20mV open drain		1.5		Ω

1. Not tested, guaranteed by process.

Table 7. Pre-irradiation switching times

Symbol	Parameter	Test conditions	Min.	Typ.	Max	Unit
$t_{d(on)}$	Turn-on delay time	$V_{DD} = 50\text{ V}, I_D = 17\text{ A},$ $R_G = 4.7\ \Omega, V_{GS} = 12\text{ V}$	15	24	33	ns
t_r	Rise time		19	31	43	ns
$t_{d(off)}$	Turn-off-delay time		68	129	190	ns
t_f	Fall time		34	46	58	ns

Table 8. Pre-irradiation source drain diode ⁽¹⁾

Symbol	Parameter	Test conditions	Min.	Typ.	Max	Unit
I_{SD} $I_{SDM}^{(2)}$	Source-drain current Source-drain current (pulsed)				34 136	A A
$V_{SD}^{(3)}$	Forward on voltage	$I_{SD} = 30\text{ A}, V_{GS} = 0$		1.1		V
$t_{rr}^{(4)}$ $Q_{rr}^{(4)}$ $I_{RRM}^{(4)}$	Reverse recovery time Reverse recovery charge Reverse recovery current	$I_{SD} = 34\text{ A},$ $di/dt = 40\text{ A}/\mu\text{s}$ $V_{DD} = 12\text{ V}, T_J = 25\text{ }^\circ\text{C}$	276	345 4.1 316	414	ns μC A
$t_{rr}^{(4)}$ $Q_{rr}^{(4)}$ $I_{RRM}^{(4)}$	Reverse recovery time Reverse recovery charge Reverse recovery current	$I_{SD} = 34\text{ A},$ $di/dt = 40\text{ A}/\mu\text{s}$ $V_{DD} = 12\text{ V}, T_J = 150\text{ }^\circ\text{C}$		473 7.1 133		ns μC A

1. Refer to the [Figure 16](#).
2. Pulse width limited by safe operating area.
3. Pulsed: pulse duration = 300 μs , duty cycle 1.5%.
4. Not tested in production, guaranteed by process.

3 Radiation characteristics

The technology of the STMicroelectronics rad-hard Power MOSFETs is extremely resistant to radiative environments. Every manufacturing lot is tested (using the TO-3 package) for total ionizing dose according to the ESCC 22900 specification, window 1) and Single Event Effect according to the MIL-STD-750E TM1080 up to a fluency level of $3e+5$ ions/cm². Both pre-irradiation and post-irradiation performances are tested and specified using the same circuitry and test conditions in order to provide a direct comparison.

($T_{amb} = 22 \pm 3$ °C unless otherwise specified).

Total dose radiation (TID) testing

One bias conditions using the TO-3 package:

- V_{GS} bias: from +15 V applied and $V_{DS} = 0$ V during irradiation

The following parameters are measured (see [Table 9](#), [Table 10](#) and [Table 11](#)):

- before irradiation
- after irradiation
- after 24 hrs @ room temperature
- after 168 hrs @ 100 °C anneal

Table 9. Post-irradiation on/off states @ $T_J = 25$ °C, (Co60 γ rays 100 K Rad(Si))

Symbol	Parameter	Test conditions	Drift values Δ	Unit
I_{DSS}	Zero gate voltage drain current ($V_{GS} = 0$)	80% BV_{DSS}	+1	μA
I_{GSS}	Gate body leakage current ($V_{DS} = 0$)	$V_{GS} = 12$ V $V_{GS} = -12$ V	1.5 -1.5	μA
BV_{DSS}	Drain-to-source breakdown voltage	$V_{GS} = 0$, $I_D = 1$ mA	+5%	V
$V_{GS(th)}$	Gate threshold voltage	$V_{DS} = V_{GS}$, $I_D = 1$ mA	+150%	V
$R_{DS(on)}$	Static drain-source on resistance	$V_{GS} = 10$ V; $I_D = 20$ A	-4% / +35%	Ω

Table 10. Dynamic post-irradiation @ $T_J = 25$ °C, (Co60 γ rays 100 K Rad(Si)) ⁽¹⁾

Symbol	Parameter	Test conditions	Drift values Δ	Unit
Q_g	Total gate charge	$I_G = 1$ mA, $V_{GS} = 12$ V, $V_{DS} = 50$ V, $I_{DS} = 20$ A	-15% / +5%	nC
Q_{gs}	Gate-source charge		-5% / +200%	
Q_{gd}	Gate-drain charge		-10% / +100%	

1. Parameter not measured after irradiation but guaranteed by the results obtained during the evaluation phase that proves this parameter is directly correlated to the $V_{GS(th)}$ shift.

Table 11. Source drain diode post-irradiation @ T_J= 25 °C, (Co60 γ rays 100 K Rad(Si))⁽¹⁾

Symbol	Parameter	Test conditions	Drift values Δ.	Unit
V _{SD} ⁽²⁾	Forward on voltage	I _{SD} = 40 A, V _{GS} = 0	± 5%	V

1. Refer to [Figure 16](#).
2. Pulsed: pulse duration = 300 μs, duty cycle 1.5%

Single event effect, SOA

The technology of the STMicroelectronics rad-hard Power MOSFETs is extremely resistant to heavy ion environment for single event effect (irradiation per MIL-STD-750E, method 1080 bias circuit in [Figure 3: Single event effect, bias circuit](#)). SEB and SEGR tests have been performed with a fluence of 3e+5 ions/cm².

The accept/reject criteria are:

- SEB test: drain voltage checked, trigger level is set to V_{ds} = - 5 V. Stop condition: as soon as a SEB occurs or if the fluence reaches 3e+5 ions/cm².
- SEGR test: the gate current is monitored every 200 ms. A gate stress is performed before and after irradiation. Stop condition: as soon as the gate current reaches 100 nA (during irradiation or during PIGS test) or if the fluence reaches 3e+5 ions/cm².

The results are:

- no SEB
- SEGR test produces the following SOA (see [Table 12: Single event effect \(SEE\), safe operating area \(SOA\)](#) and [Figure 2: Single event effect, SOA](#))

Table 12. Single event effect (SEE), safe operating area (SOA)

Ion	Let (Mev/(mg/cm ²))	Energy (MeV)	Range (μm)	V _{DS} (V)				
				@V _{GS} =0	@V _{GS} = 2 V	@V _{GS} = 5 V	@V _{GS} = 10 V	@V _{GS} = 15 V
Kr	32	768	94	-	-60	-	-	-
		756	92	-	-	-	-	-20
Cu	28	285	43	-100	-	-60	-	-
Xe	60	1217	89	-	-30	-	-	-

Figure 2. Single event effect, SOA

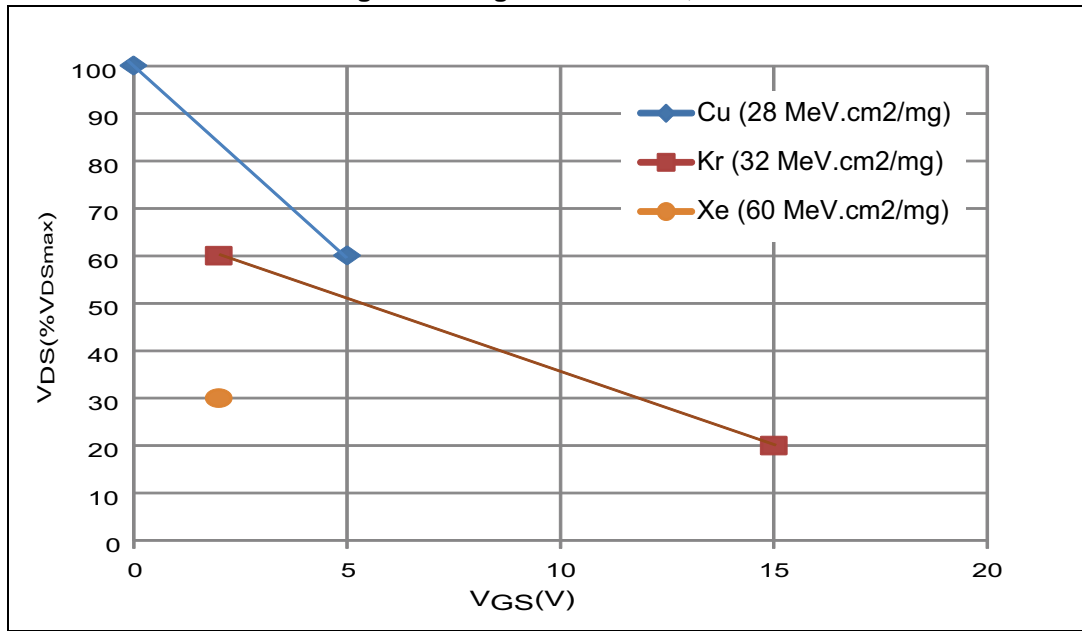
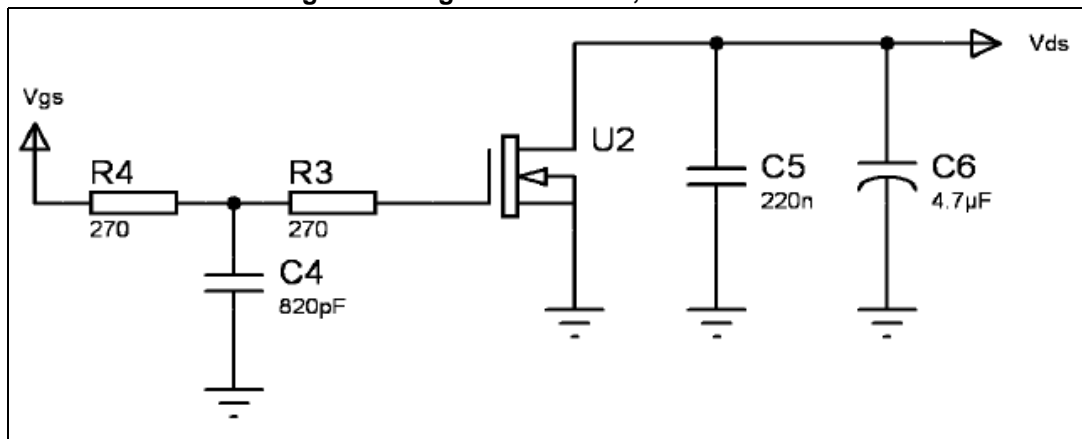

Figure 3. Single event effect, bias circuit^(a)



a. Bias condition during radiation refer to [Table 12: Single event effect \(SEE\), safe operating area \(SOA\)](#) .

4 Electrical characteristics (curves)

Figure 4. Safe operating area

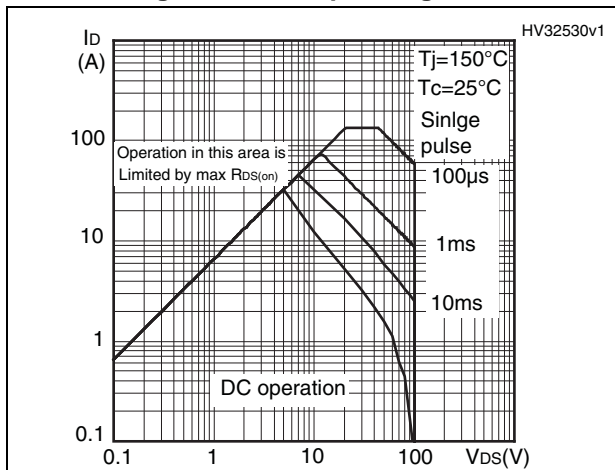

Figure 5. Thermal impedance

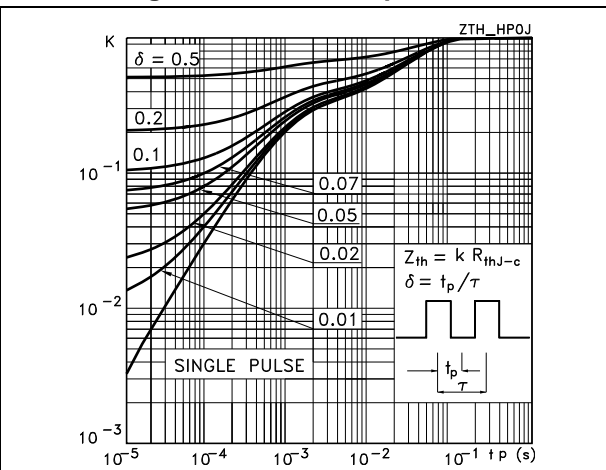

Figure 6. Output characteristics

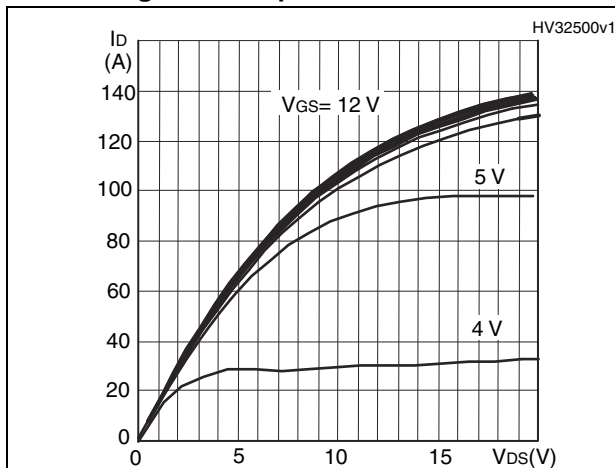

Figure 7. Transfer characteristics

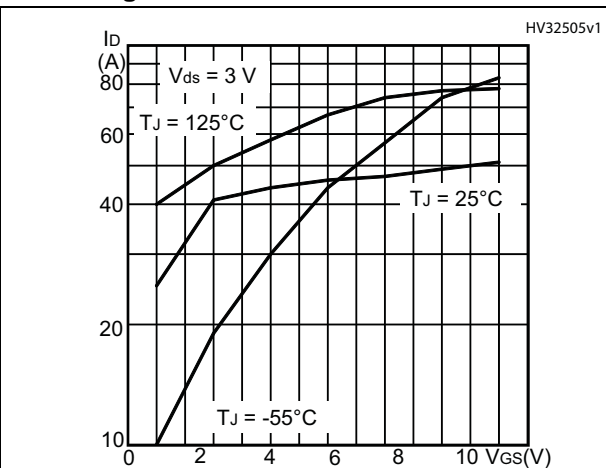

Figure 8. Gate charge vs gate-source voltage

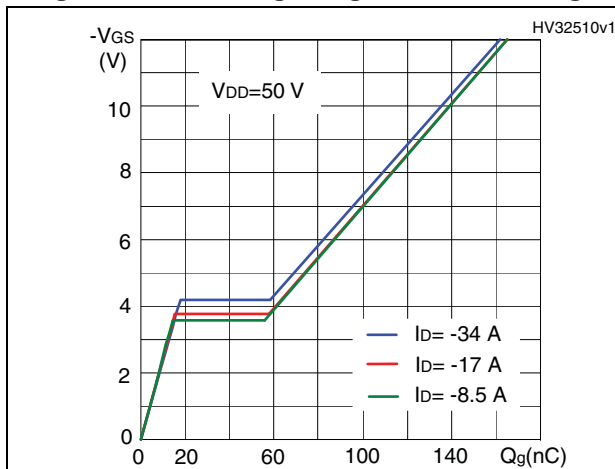

Figure 9. Capacitance variations

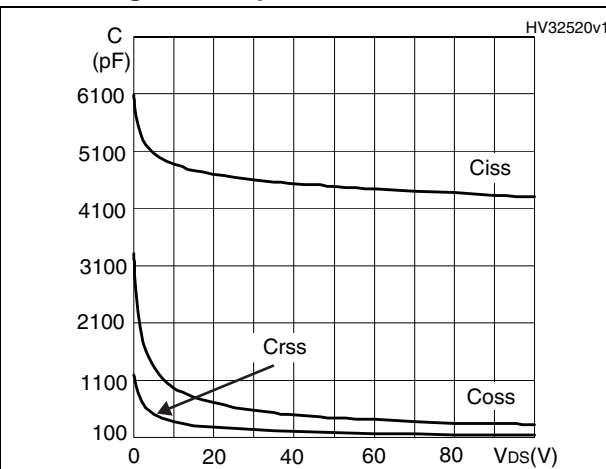

Figure 10. Normalized BV_{DSS} vs temperature

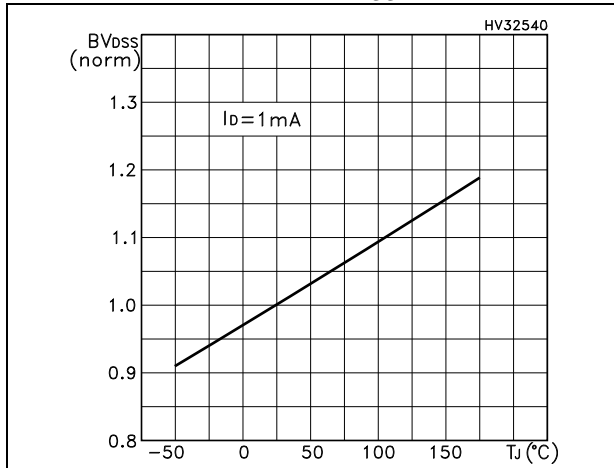

Figure 11. Static drain-source on resistance

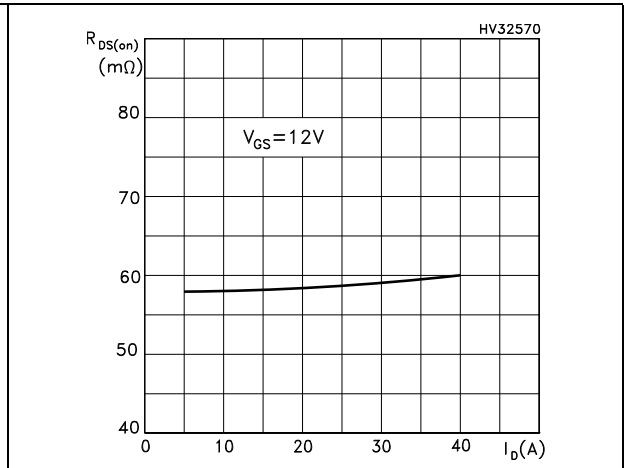

Figure 12. Normalized gate threshold voltage vs temperature

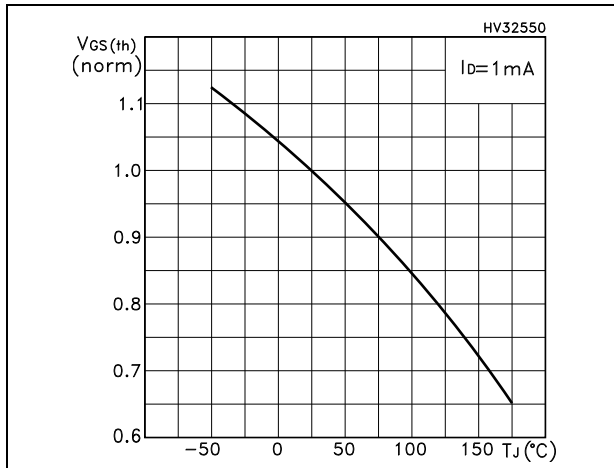

Figure 13. Normalized on resistance vs temperature

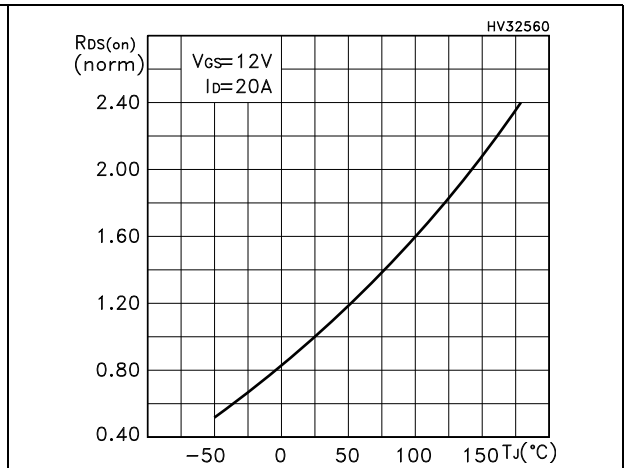
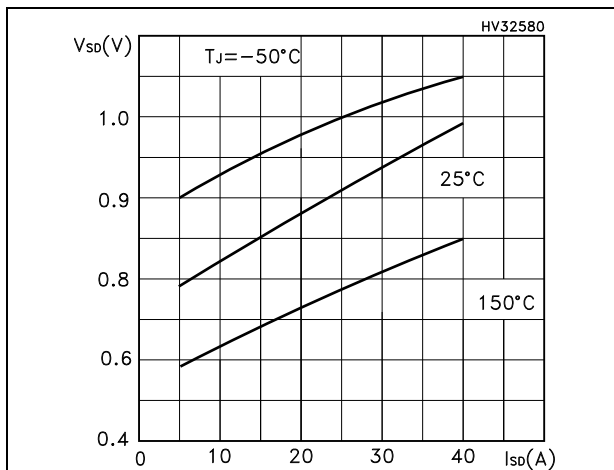
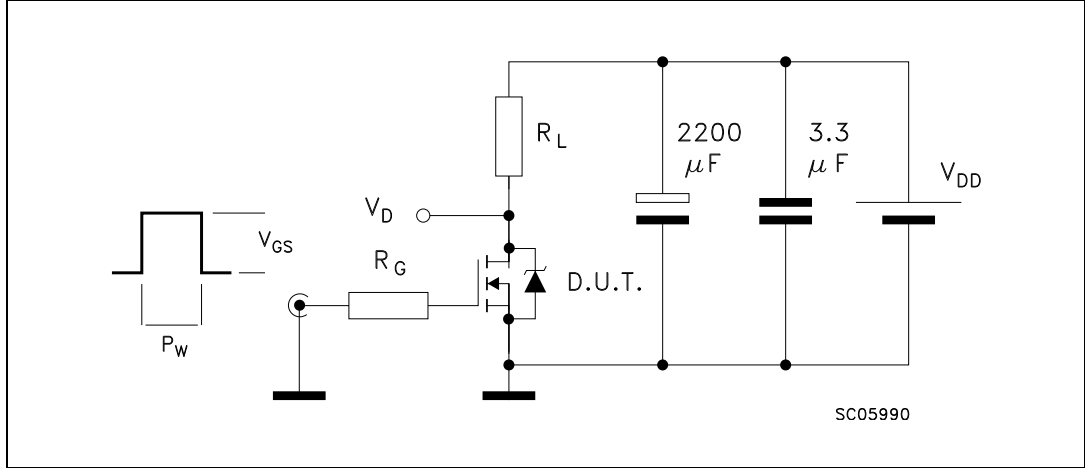

Figure 14. Source drain-diode forward characteristics



5 Test circuits

Figure 15. Switching times test circuit for resistive load (1)



1. Max driver V_{GS} slope = 1V/ns (no DUT)

Figure 16. Source drain diode

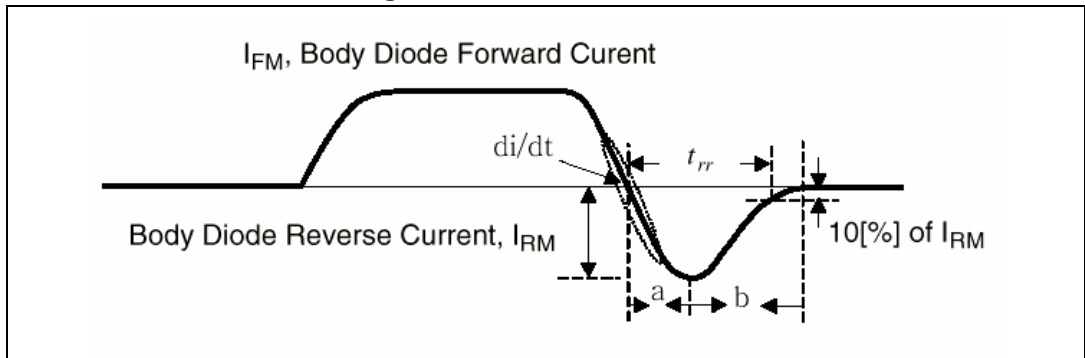
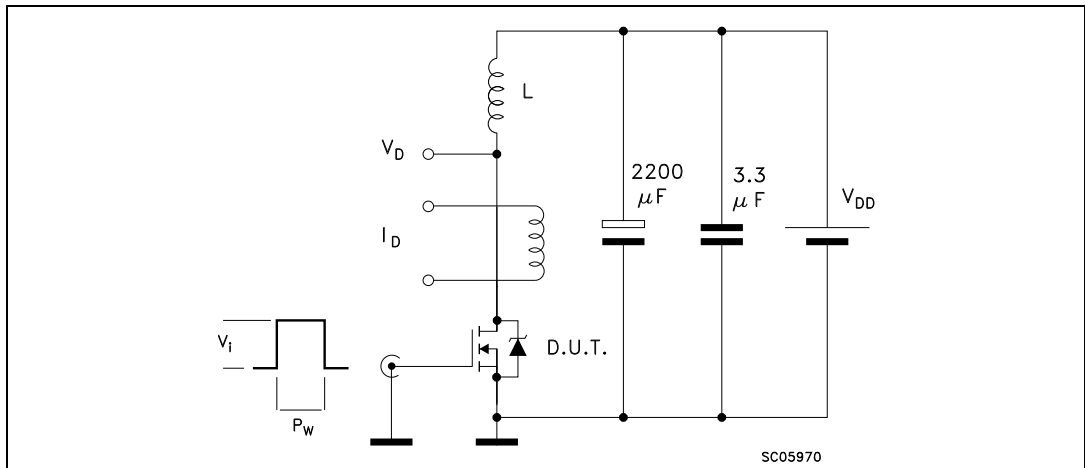

Figure 17. Unclamped inductive load test circuit (single pulse and repetitive)



6 Package mechanical data

In order to meet environmental requirements, ST offers these devices in different grades of ECOPACK® packages, depending on their level of environmental compliance. ECOPACK® specifications, grade definitions and product status are available at: www.st.com. ECOPACK® is an ST trademark.

Figure 18. TO-254AA drawing

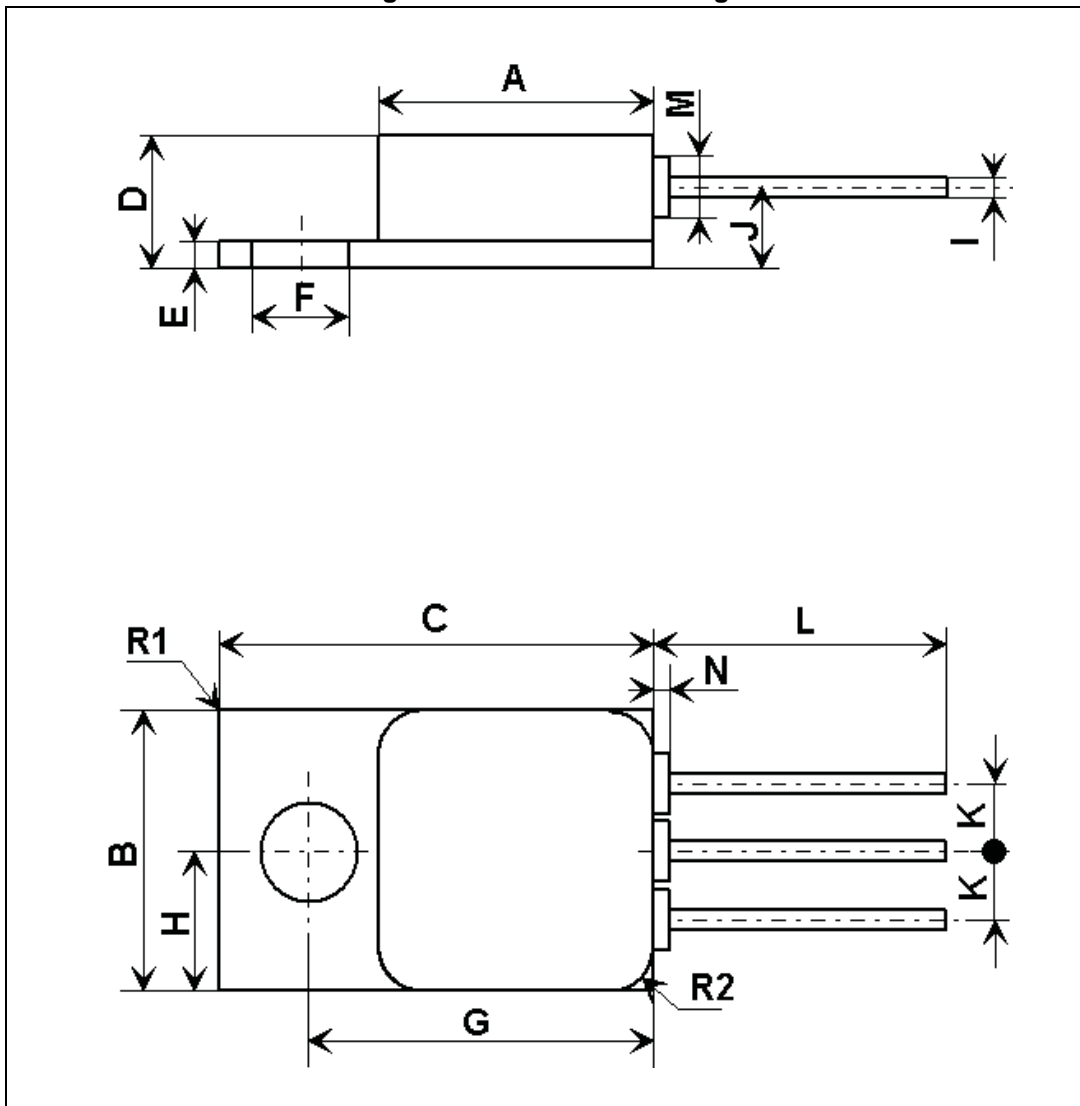

Table 13. TO-254AA mechanical data

Dim.	mm			Inch		
	Min.	Typ.	Max.	Min.	Typ.	Max.
A	13.59		13.84	0.535		0.545
B	13.59		13.84	0.535		0.545
C	20.07		20.32	0.790		0.800
D	6.32		6.60	0.249		0.260
E	1.02		1.27	0.040		0.050
F	3.56		3.81	0.140		0.150
G	16.89		17.40	0.665		0.685
H		6.86			0.270	
I	0.89	1.02	1.14	0.035	0.040	0.045
J		3.81			0.150	
K		3.81			0.150	
L	12.95		14.50	0.510		0.571
M	2.92		3.18			
N			0.71			
R1			1.00			0.039
R2	1.52	1.65	1.78	0.060	0.065	0.070

7 Order codes

Table 14. Ordering information

Order code	ESCC part number	Quality level	EPPL	Package	Lead finish	Marking	Packing
STRH40P10HY1	-	Engineering model	-	TO-254AA	Gold	STRH40P10HY1 + BeO	Strip pack
STRH40P10HYG	5205/025/01	ESCC flight	Target		Solder dip	520502501R + BeO	
STRH40P10HYT	5205/025/02		-			520502502R + BeO	

For specific marking only the complete structure is:

- ST Logo
- ESA Logo
- Date code (date of sealing of the package): YYWWA
 - YY: year
 - WW: week number
 - A: week index
- ESCC part number (as mentioned in the table)
- Warning signs (e.g. BeO)
- Country of origin: FR (France)

Part serial number within in the assembly lot

Contact ST sales office for information about the specific conditions for products in die form and for other packages.

8 Shipping details

8.1 Date code

The date code for “ESCC flight” is structured as follows: yywwz

where:

- yy: last two digits of year
- ww: week digits
- z: lot index in the week

8.2 Documentation

The table below provide a summary of the documentation provided with each type of products.

Table 15. Documentation provide for each type of product

Quality level	Radiation level	Documentation
Engineering model	-	-
ESCC flight	100 krad	Certificate of conformance Radiation verification test report

9 Revision history

Table 16. Document revision history

Date	Revision	Changes
23-Dec-2010	1	First release.
02-Feb-2011	2	Updated Figure 1 .
03-May-2011	3	Updated Figure 1 .
22-Jun-2011	4	Updated features on coverpage.
25-Jul-2011	5	Updated order codes in Table 1: Device summary and Table 14: Ordering information . Minor text changes.
09-Nov-2011	6	Updated dynamic values on Table 6: Pre-irradiation dynamic , Table 7: Pre-irradiation switching times and Table 8: Pre-irradiation source drain diode .
12-Dec-2012	7	Updated Figure 2: Single event effect, SOA
17-Dec-2012	8	Modified: $t_{d(off)}$ value in Table 7: Pre-irradiation switching times
13-Jun-2013	9	Modified: Table 1: Device summary and Table 14: Ordering information
09-Sep-2013	10	Updated features in cover page.
27-Sep-2013	11	Updated I_{AR} value in Table 4: Avalanche characteristics .
17-Dec-2013	12	Total dose radiation testing parameters changed in Section 3: Radiation characteristics .
25-Aug-2014	13	Updated Figure 7: Transfer characteristics .

IMPORTANT NOTICE – PLEASE READ CAREFULLY

STMicroelectronics NV and its subsidiaries (“ST”) reserve the right to make changes, corrections, enhancements, modifications, and improvements to ST products and/or to this document at any time without notice. Purchasers should obtain the latest relevant information on ST products before placing orders. ST products are sold pursuant to ST’s terms and conditions of sale in place at the time of order acknowledgement.

Purchasers are solely responsible for the choice, selection, and use of ST products and ST assumes no liability for application assistance or the design of Purchasers’ products.

No license, express or implied, to any intellectual property right is granted by ST herein.

Resale of ST products with provisions different from the information set forth herein shall void any warranty granted by ST for such product.

ST and the ST logo are trademarks of ST. All other product or service names are the property of their respective owners.

Information in this document supersedes and replaces information previously supplied in any prior versions of this document.

© 2014 STMicroelectronics – All rights reserved