

## Automotive-grade N-channel 100 V, 180 A, 3.9 mΩ typ., STripFET™ F3 Power MOSFET in a H<sup>2</sup>PAK-6 package

Datasheet - production data

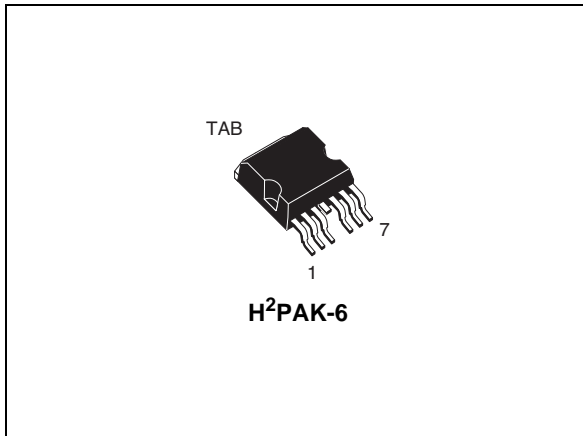
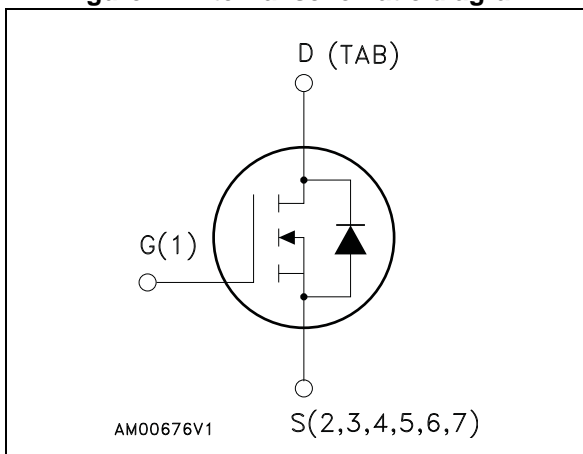

Figure 1. Internal schematic diagram



### Features

Order code	V <sub>DS</sub>	R <sub>DS(on)</sub> max.	I <sub>D</sub>
STH185N10F3-6	100 V	4.5 mΩ	180 A

- Designed for automotive applications and AEC-Q101 qualified
- Ultra low on-resistance
- 100% avalanche tested

### Applications

- Switching applications

### Description

This device is an N-channel Power MOSFET developed using STripFET™ F3 technology. It is designed to minimize on-resistance and gate charge to provide superior switching performance.

Table 1. Device summary

Order code	Marking	Packages	Packaging
STH185N10F3-6	185N10F3	H <sup>2</sup> PAK-6	Tape and reel

---

# Contents

<b>1</b>	<b>Absolute ratings</b> .....	<b>3</b>
<b>2</b>	<b>Electrical characteristics</b> .....	<b>4</b>
	2.1 Electrical characteristics (curves) .....	6
<b>3</b>	<b>Test circuits</b> .....	<b>8</b>
<b>4</b>	<b>Package mechanical data</b> .....	<b>9</b>
<b>5</b>	<b>Packaging mechanical data</b> .....	<b>13</b>
<b>6</b>	<b>Revision history</b> .....	<b>15</b>

# 1 Absolute ratings

**Table 2. Absolute maximum ratings**

Symbol	Parameter	Value	Unit
$V_{DS}$	Drain-source voltage	100	V
$V_{GS}$	Gate-source voltage	$\pm 20$	V
$I_D^{(1)}$	Drain current (continuous) at $T_C = 25^\circ\text{C}$	180	A
$I_D^{(1)}$	Drain current (continuous) at $T_C=100^\circ\text{C}$	120	A
$I_{DM}^{(2)}$	Drain current (pulsed)	720	A
$P_{TOT}$	Total dissipation at $T_C = 25^\circ\text{C}$	315	W
	Derating factor	2.1	W/°C
dv/dt	Peak diode recovery voltage slope	20	V/ns
$E_{AS}^{(3)}$	Single pulse avalanche energy	350	mJ
$T_j$ $T_{stg}$	Operating junction temperature storage temperature	- 55 to 175	°C

1. Current limited by package.
2. Pulse width limited by safe operating area.
3. Starting  $T_j = 25^\circ\text{C}$ ,  $I_D = 80\text{ A}$ ,  $V_{DD} = 50\text{ V}$ .

**Table 3. Thermal data**

Symbol	Parameter	Value	Unit
$R_{thj-case}$	Thermal resistance junction-case	0.48	°C/W
$R_{thj-pcb}^{(1)}$	Thermal resistance junction-pcb max	35	°C/W

1. When mounted on FR-4 board, on 1inch<sup>2</sup>, 2oz Cu.

## 2 Electrical characteristics

( $T_{CASE} = 25\text{ °C}$  unless otherwise specified)

**Table 4. On/off states**

Symbol	Parameter	Test conditions	Min.	Typ.	Max.	Unit
$V_{(BR)DSS}$	Drain-source breakdown voltage	$V_{GS} = 0, I_D = 250\ \mu A$	100			V
$I_{DSS}$	Zero gate voltage drain current	$V_{GS} = 0, V_{DS} = 100\ V$			10	$\mu A$
		$V_{GS} = 0, V_{DS} = 100\ V, T_C = 125\text{ °C}$			100	$\mu A$
$I_{GSS}$	Gate body leakage current	$V_{DS} = 0, V_{GS} = \pm 20\ V$			$\pm 200$	nA
$V_{GS(th)}$	Gate threshold voltage	$V_{DS} = V_{GS}, I_D = 250\ \mu A$	2		4	V
$R_{DS(on)}$	Static drain-source on- resistance	$V_{GS} = 10\ V, I_D = 60\ A$		3.9	4.5	m $\Omega$

**Table 5. Dynamic**

Symbol	Parameter	Test conditions	Min.	Typ.	Max.	Unit
$C_{iss}$	Input capacitance	$V_{GS} = 0, V_{DS} = 25\ V, f = 1\ MHz,$	-	6665	-	pF
$C_{oss}$	Output capacitance		-	786	-	pF
$C_{riss}$	Reverse transfer capacitance		-	49	-	pF
$Q_g$	Total gate charge	$V_{DD} = 50\ V, I_D = 120\ A, V_{GS} = 10\ V$ (see <a href="#">Figure 14</a> )	-	114.6	-	nC
$Q_{gs}$	Gate-source charge		-	38.8	-	nC
$Q_{gd}$	Gate-drain charge		-	31.9	-	nC

**Table 6. Switching times**

Symbol	Parameter	Test conditions	Min.	Typ.	Max.	Unit
$t_{d(on)}$	Turn-on delay time	$V_{DD} = 50\ V, I_D = 60\ A, R_G = 4.7\ \Omega, V_{GS} = 10\ V$ (see <a href="#">Figure 13</a> , <a href="#">Figure 18</a> )	-	25.6	-	ns
$t_r$	Rise time		-	97.1	-	ns
$t_{d(off)}$	Turn-off delay time		-	99.9	-	ns
$t_f$	Fall time		-	6.9	-	ns

**Table 7. Source drain diode**

Symbol	Parameter	Test conditions	Min.	Typ.	Max.	Unit
$I_{SD}$	Source-drain current		-		180	A
$I_{SDM}^{(1)}$	Source-drain current (pulsed)		-		720	A
$V_{SD}^{(2)}$	Forward on voltage	$V_{GS}=0, I_{SD}=120\text{ A}$	-		1.5	V
$t_{rr}$	Reverse recovery time	$I_{SD}=120\text{ A},$ $di/dt = 100\text{ A}/\mu\text{s},$ $V_{DD}=80\text{ V}, T_j=150^\circ\text{C}$ (see <a href="#">Figure 15</a> )	-	83.4		ns
$Q_{rr}$	Reverse recovery charge		-	295.7		nC
$I_{RRM}$	Reverse recovery current		-	7.1		A

1. Pulse width limited by safe operating area.
2. Pulsed: pulse duration = 300µs, duty cycle 1.5%

## 2.1 Electrical characteristics (curves)

Figure 2. Safe operating area

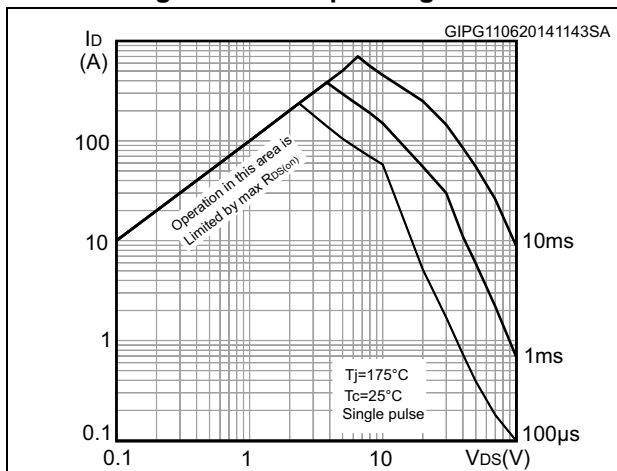

Figure 3. Thermal impedance

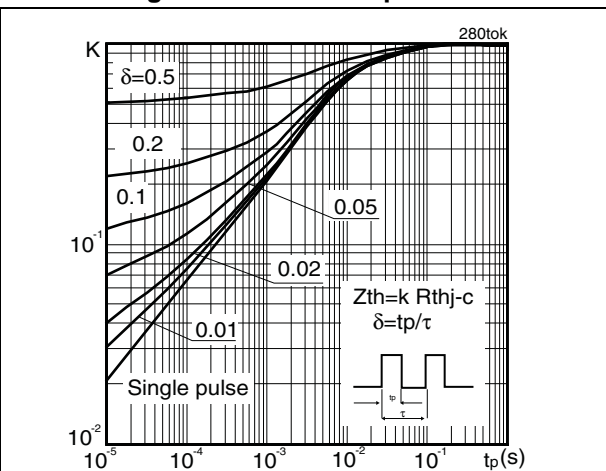

Figure 4. Output characteristics

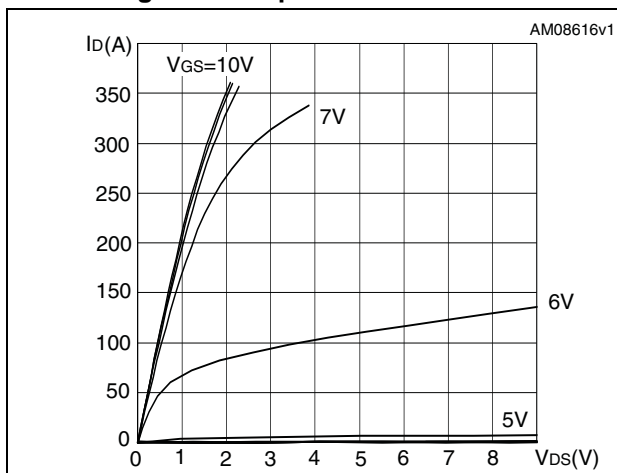

Figure 5. Transfer characteristics

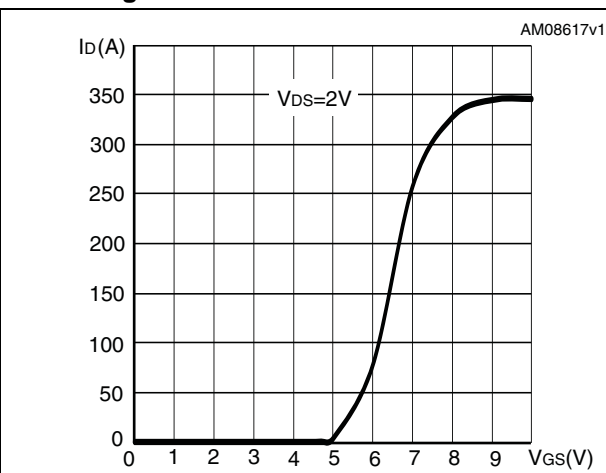

Figure 6. Normalized  $V_{(BR)DSS}$  vs temperature

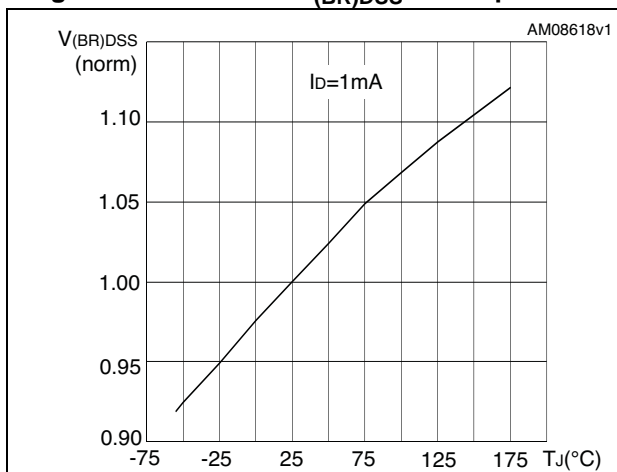

Figure 7. Static drain-source on-resistance

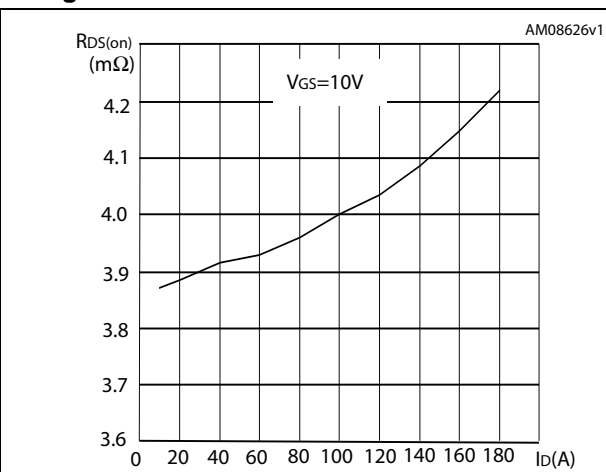

Figure 8. Gate charge vs gate-source voltage

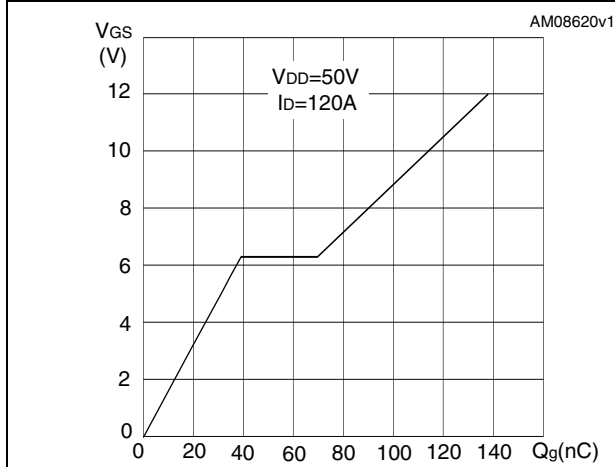

Figure 9. Capacitance variations

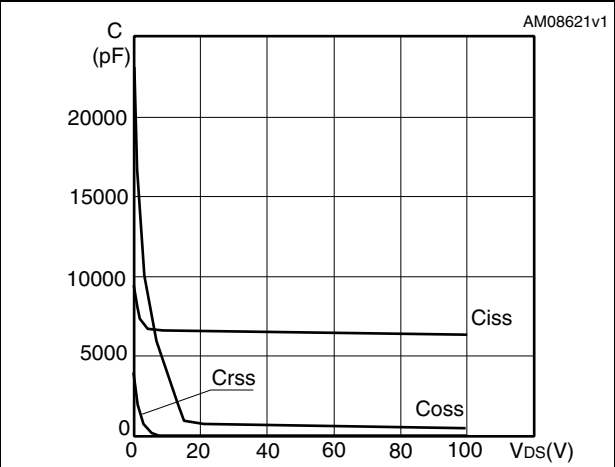

Figure 10. Normalized gate threshold voltage vs temperature

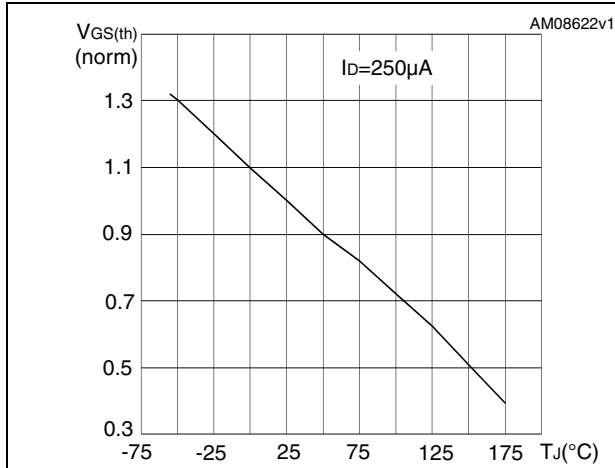

Figure 11. Normalized on-resistance vs temperature

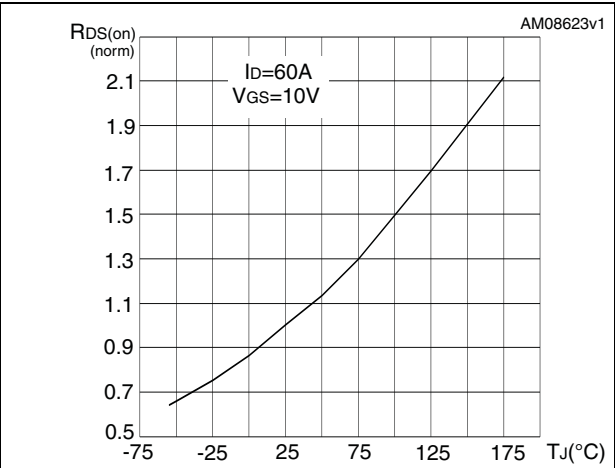
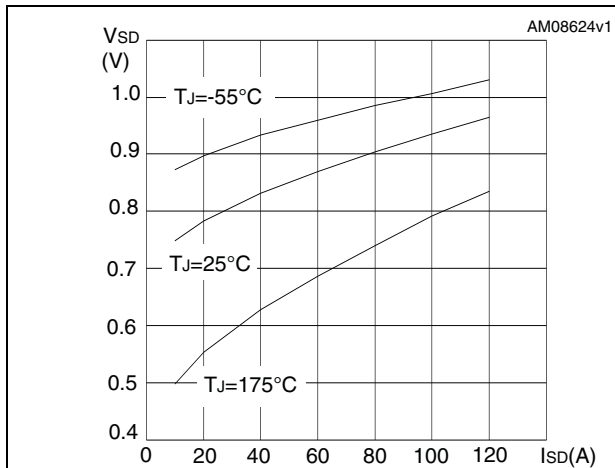

Figure 12. Source-drain diode forward characteristics



### 3 Test circuits

Figure 13. Switching times test circuit for resistive load

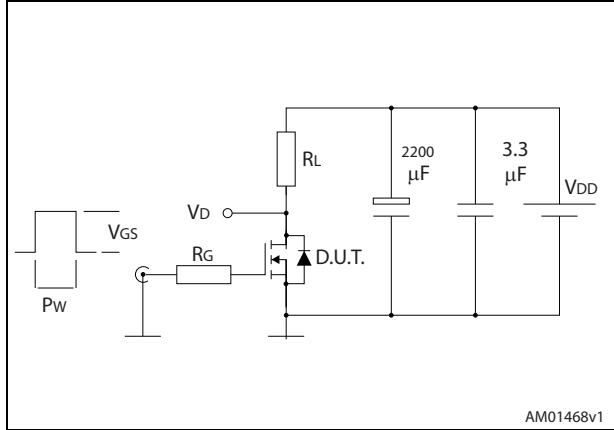

Figure 14. Gate charge test circuit

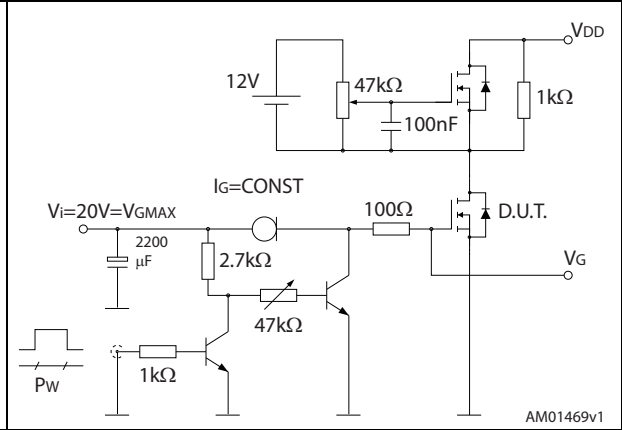

Figure 15. Test circuit for inductive load switching and diode recovery times

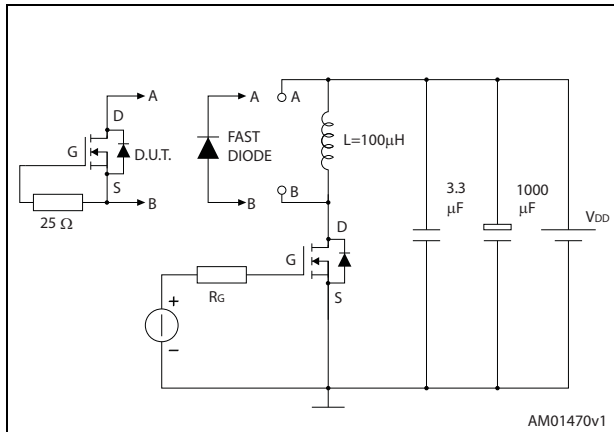

Figure 16. Unclamped inductive load test circuit

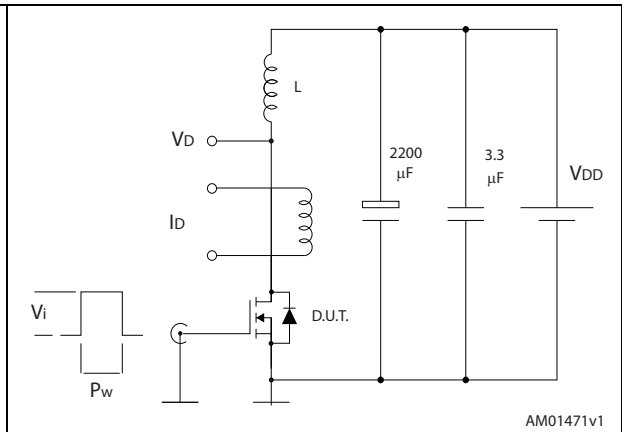

Figure 17. Unclamped inductive waveform

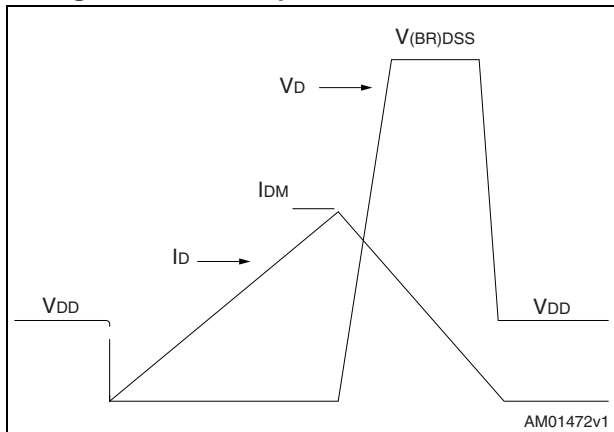
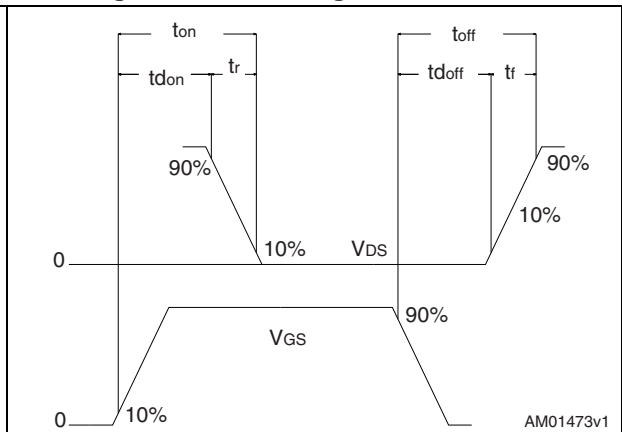

Figure 18. Switching time waveform



## 4 Package mechanical data

In order to meet environmental requirements, ST offers these devices in different grades of ECOPACK<sup>®</sup> packages, depending on their level of environmental compliance. ECOPACK<sup>®</sup> specifications, grade definitions and product status are available at: [www.st.com](http://www.st.com). ECOPACK<sup>®</sup> is an ST trademark.

Figure 19. H<sup>2</sup>PAK-6 drawing

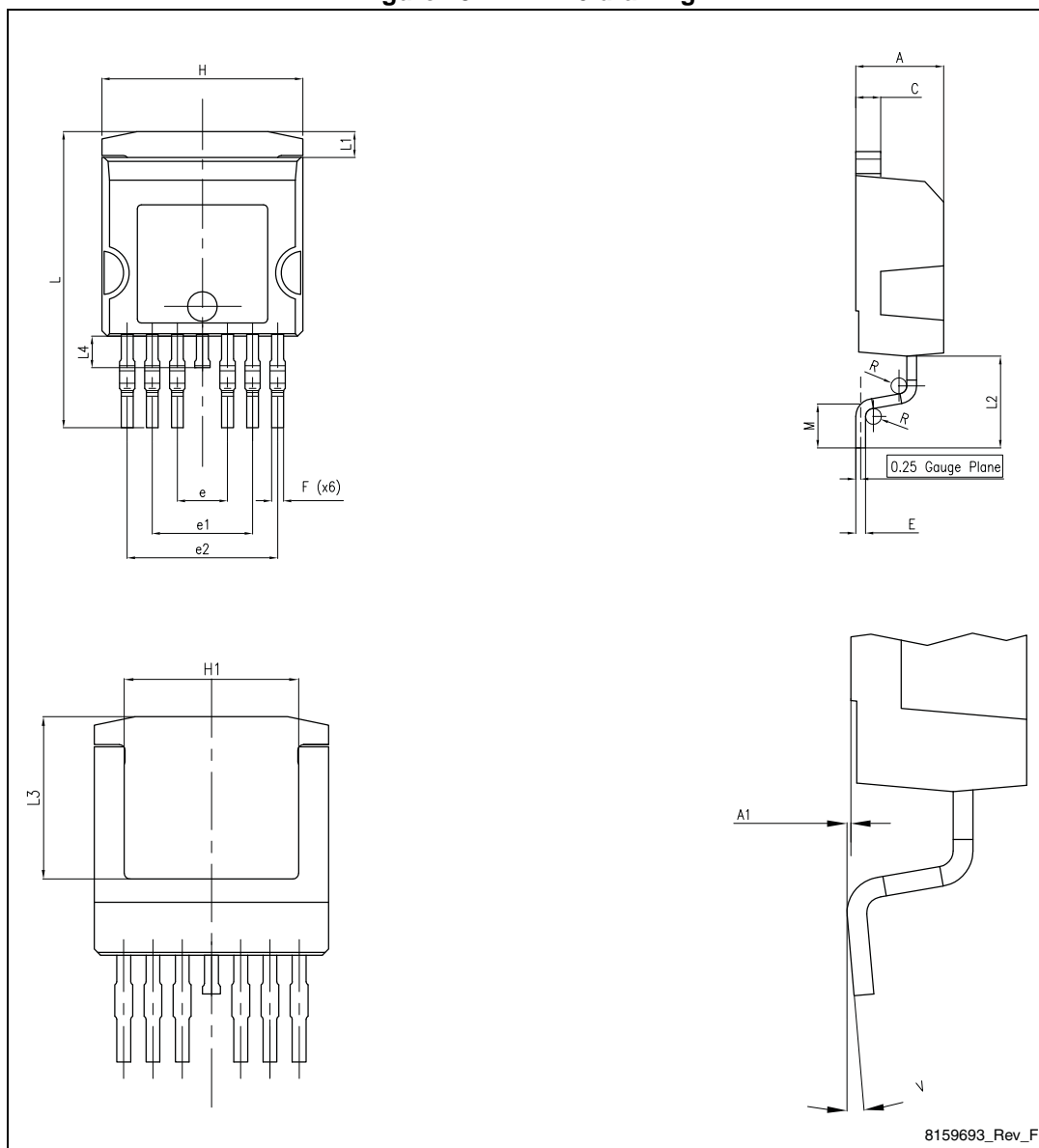

8159693\_Rev\_F

Table 8. H<sup>2</sup>PAK-6 mechanical data

Dim.	mm		
	Min.	Typ.	Max.
A	4.30		4.80
A1	0.03		0.20
C	1.17		1.37
e	2.34		2.74
e1	4.88		5.28
e2	7.42		7.82
E	0.45		0.60
F	0.50		0.70
H	10.00		10.40
H1	7.40		7.80
L	14.75		15.25
L1	1.27		1.40
L2	4.35		4.95
L3	6.85		7.25
L4	1.5		1.75
M	1.90		2.50
R	0.20		0.60
V	0°		8°

Figure 20. H<sup>2</sup>PAK-6 recommended footprint (dimensions are in mm)

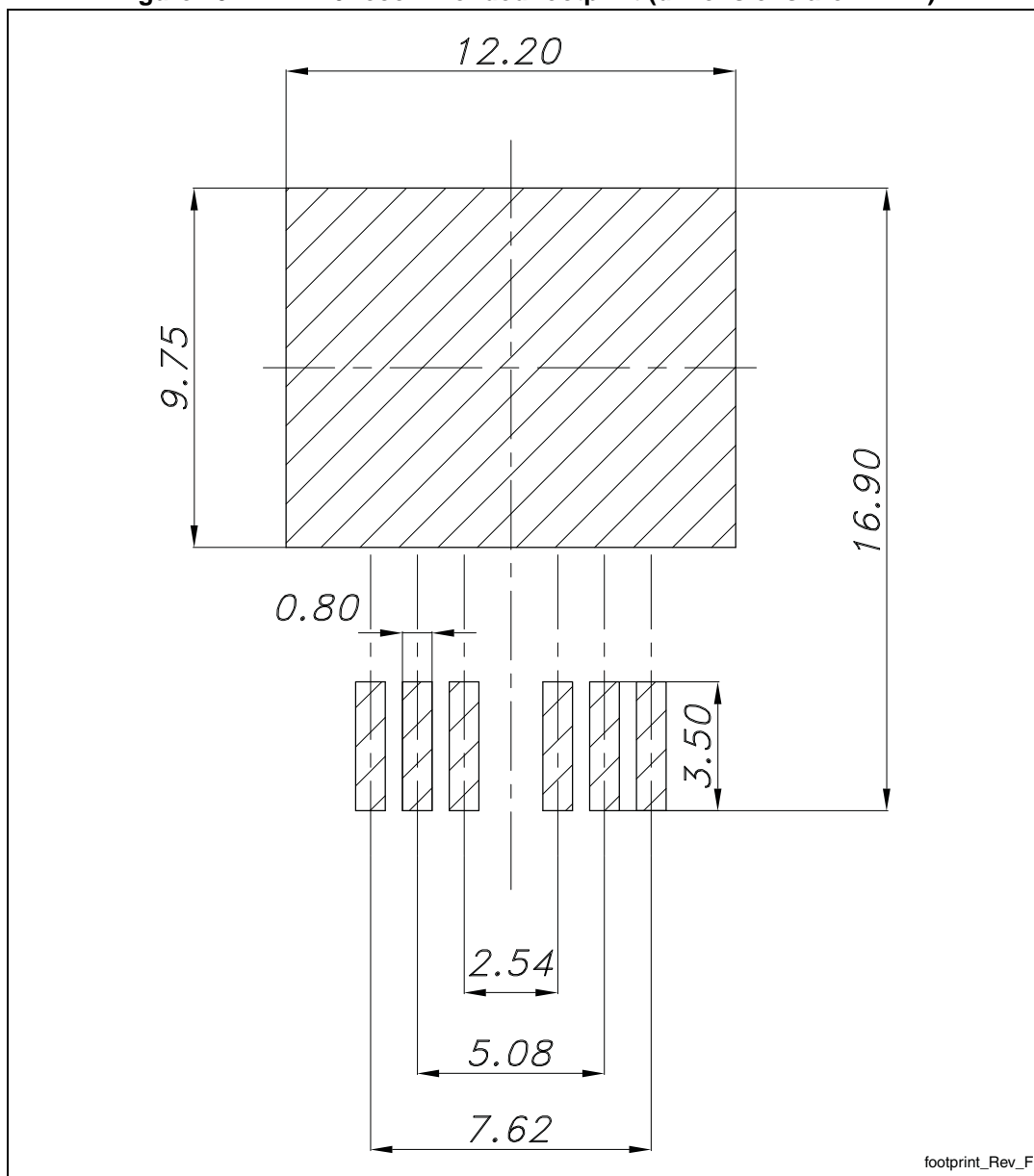

# 5 Packaging mechanical data

Figure 21. Tape

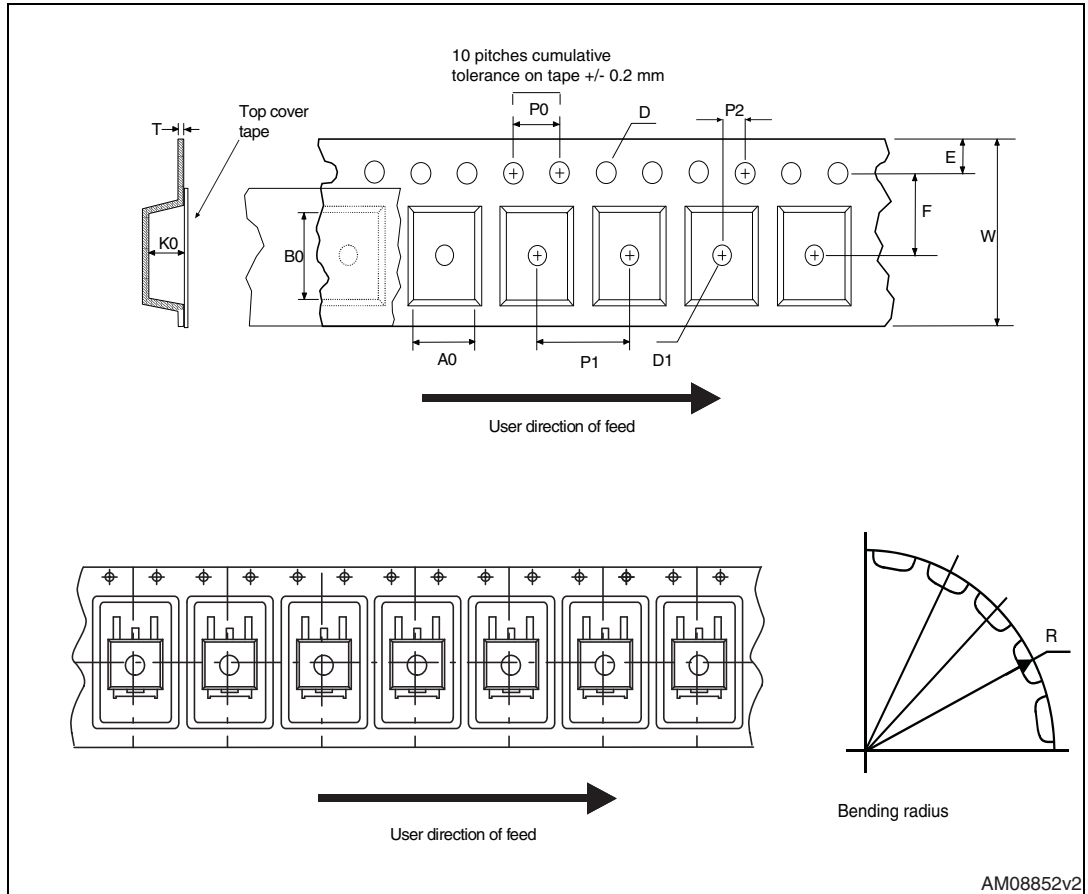

AM08852v2

Figure 22. Reel

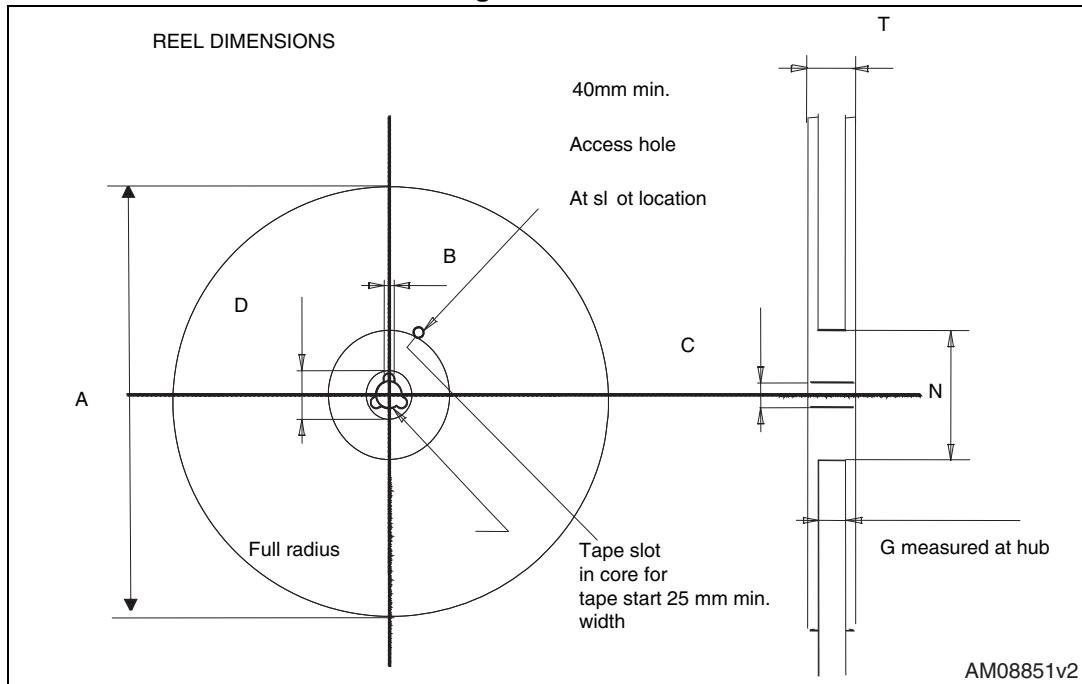

Table 9. H<sup>2</sup>PAK 2 leads tape and reel mechanical data

Tape			Reel		
Dim.	mm		Dim.	mm	
	Min.	Max.		Min.	Max.
A0	10.5	10.7	A		330
B0	15.7	15.9	B	1.5	
D	1.5	1.6	C	12.8	13.2
D1	1.59	1.61	D	20.2	
E	1.65	1.85	G	24.4	26.4
F	11.4	11.6	N	100	
K0	4.8	5.0	T		30.4
P0	3.9	4.1			
P1	11.9	12.1	Base qty		1000
P2	1.9	2.1	Bulk qty		1000
R	50				
T	0.25	0.35			
W	23.7	24.3			

## 6 Revision history

Table 10. Document revision history

Date	Revision	Changes
12-Dec-2014	1	First version.

**IMPORTANT NOTICE – PLEASE READ CAREFULLY**

STMicroelectronics NV and its subsidiaries ("ST") reserve the right to make changes, corrections, enhancements, modifications, and improvements to ST products and/or to this document at any time without notice. Purchasers should obtain the latest relevant information on ST products before placing orders. ST products are sold pursuant to ST's terms and conditions of sale in place at the time of order acknowledgement.

Purchasers are solely responsible for the choice, selection, and use of ST products and ST assumes no liability for application assistance or the design of Purchasers' products.

No license, express or implied, to any intellectual property right is granted by ST herein.

Resale of ST products with provisions different from the information set forth herein shall void any warranty granted by ST for such product.

ST and the ST logo are trademarks of ST. All other product or service names are the property of their respective owners.

Information in this document supersedes and replaces information previously supplied in any prior versions of this document.

© 2014 STMicroelectronics – All rights reserved