

LOW VOLTAGE 5Ω MAX QUAD SPDT SWITCH WITH BREAK BEFORE MAKE FEATURE

- HIGH SPEED:
 - $t_{PD} = 0.3ns$ (TYP.) at $V_{CC} = 3.0V$
 - $t_{PD} = 0.4ns$ (TYP.) at $V_{CC} = 2.3V$
- ULTRA LOW POWER DISSIPATION:
 - $I_{CC} = 0.2\mu A$ (MAX.) at $T_A = 85^\circ C$
- LOW "ON" RESISTANCE $V_{IN}=0V$:
 - $R_{ON} = 1.7\Omega$ (MAX. $T_A = 25^\circ C$) at $V_{CC} = 2.7V$
 - $R_{ON} = 2.0\Omega$ (MAX. $T_A = 25^\circ C$) at $V_{CC} = 2.3V$
 - $R_{ON} = 3.2\Omega$ (MAX. $T_A = 25^\circ C$) at $V_{CC} = 1.8V$
- WIDE OPERATING VOLTAGE RANGE:
 - V_{CC} (OPR) = 1.65V to 3.6V SINGLE SUPPLY
- 3.6V TOLERANT AND 1.8V COMPATIBLE THRESHOLD ON DIGITAL CONTROL INPUT at $V_{CC} = 2.3$ to $3.0V$
- LATCH-UP PERFORMANCE EXCEEDS 300mA (JESD 17)
- ESD PERFORM. (ANALOG CHAN. vs GND):
 - HBM > 7KV (MIL STD 883 method 3015)

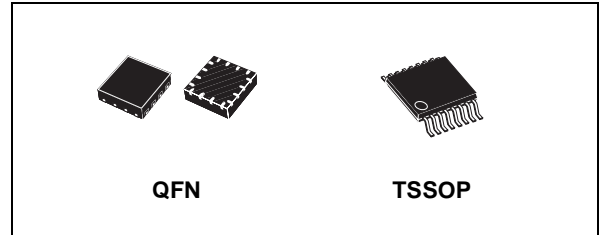

Table 1: Order Codes

PACKAGE	T & R
TSSOP	STG3690TTR
QFN	STG3690QTR

DESCRIPTION

The STG3690 is an high-speed CMOS LOW VOLTAGE QUAD ANALOG S.P.D.T. (Single Pole Dual Throw) SWITCH or 2:1 Multiplexer/ Demultiplexer Switch fabricated in silicon gate C²MOS technology. It is designed to operate from 1.65V to 3.6V, making this device ideal for portable applications.

It offers very low ON-Resistance (<5Ω) at $V_{CC}=3.0V$. The nIN inputs are provided to control the switches. The switches nS1 are ON (they are

connected to common Ports Dn) when the nIN input is held high and OFF (high impedance state exists between the two ports) when nIN is held low; the switches nS2 are ON (they are connected to common Ports Dn) when the nIN input is held low and OFF (high impedance state exists between the two ports) when IN is held high. Additional key features are fast switching speed, Break Before Make Delay Time and Ultra Low Power Consumption. All inputs and outputs are equipped with protection circuits against static discharge, giving them ESD immunity and transient excess voltage. It's available in the commercial temperature range in TSSOP and QFN3x3mm package.

Figure 1: Pin Connection

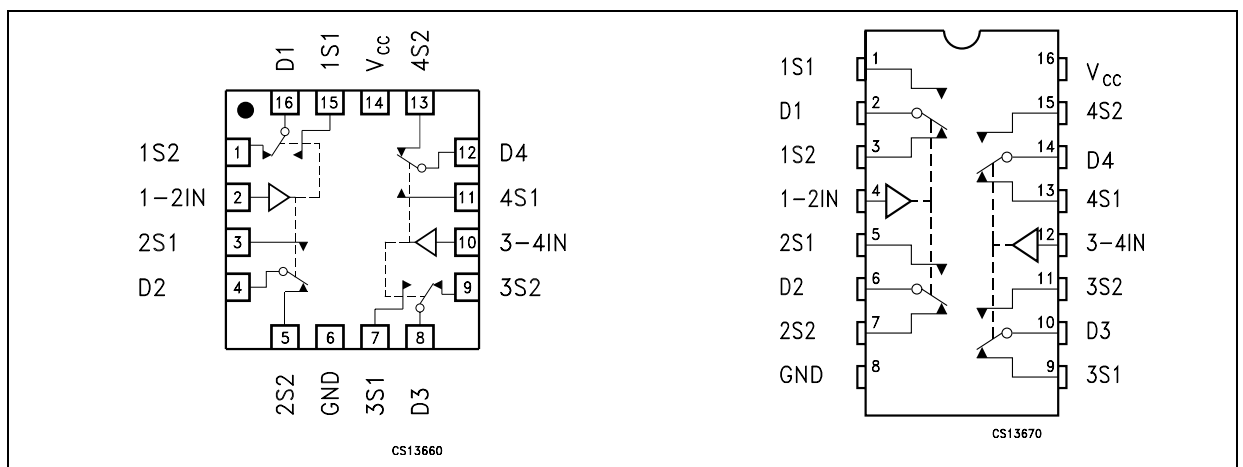

Figure 2: Input Equivalent Circuit

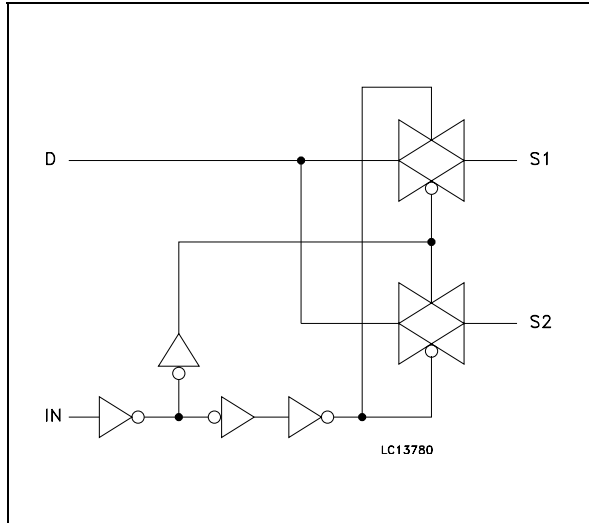

Figure 3: Absolute Maximum Ratings

Symbol	Parameter	Value	Unit	
V_{CC}	Supply Voltage	-0.5 to 4.6	V	
V_I	DC Input Voltage	-0.5 to $V_{CC} + 0.5$	V	
V_{IC}	DC Control Input Voltage	-0.5 to 4.6	V	
V_O	DC Output Voltage	-0.5 to $V_{CC} + 0.5$	V	
I_{IKC}	DC Input Diode Current on control pin ($V_{IN} < 0V$)	- 50	mA	
I_{IK}	DC Input Diode Current ($V_{IN} < 0V$)	± 50	mA	
I_{OK}	DC Output Diode Current	± 20	mA	
I_O	DC Output Current	± 300	mA	
I_{OP}	DC Output Current Peak (pulse at 1ms, 10% duty cycle)	± 500	mA	
I_{CC} or I_{GND}	DC V_{CC} or Ground Current	± 100	mA	
P_D	Power Dissipation at $T_a=70^\circ C$ (1)	QFN	1120	mW
		TSSOP	500	mW
T_{stg}	Storage Temperature	-65 to 150	$^\circ C$	
T_L	Lead Temperature (10 sec)	300	$^\circ C$	

Absolute Maximum Ratings are those values beyond which damage to the device may occur. Functional operation under these conditions not implied.

(1) Derate above 70°C: by 18.5mW/°C for QFN package; by 5.6mW/°C for TSSOP.

Table 4: Recommended Operating Conditions

Symbol	Parameter	Value	Unit	
V_{CC}	Supply Voltage (note 1)	1.65 to 3.6	V	
V_I	Input Voltage	0 to V_{CC}	V	
V_{IC}	Control Input Voltage	0 to 3.6	V	
V_O	Output Voltage	0 to V_{CC}	V	
T_{op}	Operating Temperature	-55 to 125	$^\circ C$	
dt/dv	Input Rise and Fall Time Control Input	$V_{CC} = 1.65V$ to $2.7V$	0 to 20	ns/V
		$V_{CC} = 3.0V$ to $3.6V$	0 to 10	

1) Truth Table guaranteed: 1.2V to 3.6V: The power supply can reach 4.3V without damaging the functional operations.

Table 2: Pin Description

TSSOP PIN N°	QFN PIN N°	SYMBOL	NAME AND FUNCTION
1, 5, 9, 13, 3, 7, 11, 15	15, 3, 7, 11, 1, 5, 9, 13	1S1 to 4S1, 1S2 to 4S2	Independent Channels
2, 6, 10, 14	16, 4, 8, 12	D1 to D4	Common Channels
4, 12	2, 10	1-2IN, 3-4IN	Controls
16	14	V_{CC}	Positive Supply Voltage
8	6	GND	Ground (0V)

Table 3: Truth Table

IN	SWITCH S1	SWITCH S2
H	ON	OFF(*)
L	OFF(*)	ON

(*) High Impedance

Table 5: DC Specifications

Symbol	Parameter	Test Conditions		Value						Unit	
		V _{CC} (V)		T _A = 25°C			-40 to 85°C		-55 to 125°C		
				Min.	Typ.	Max.	Min.	Max.	Min.		Max.
V _{IH}	High Level Input Voltage	1.65-1.95		0.65V _{CC}			0.65V _{CC}		0.65V _{CC}		V
		2.3-2.5		1.4			1.4		1.4		
		2.7-3.0		1.4			1.4		1.4		
		3.3		1.5			1.5		1.5		
		3.6		1.7			1.7		1.7		
V _{IL}	Low Level Input Voltage	1.65-1.95				0.40		0.40		0.40	V
		2.3-2.5				0.50		0.50		0.50	
		2.7-3.6				0.50		0.50		0.50	
		3.3				0.50		0.50		0.50	
		3.6				0.50		0.50		0.50	
R _{ON}	Switch ON Resistance (1)	3.0	V _S =0V to V _{CC} I _S =100mA		1.15	1.5		1.8			Ω
		2.7			1.30	1.7		2.0			
		2.3			1.45	2.0		2.4			
		1.8			1.70	3.2		3.7			
		1.65			1.80	3.5		4.0			
ΔR _{ON}	ON Resistance Match between channels (1,2)	2.7	V _S =1.5V I _S =100mA		0.06						Ω
R _{FLAT}	ON Resistance FLATNESS (3)	3.0	V _S =1.5V I _S =100mA								Ω
		2.7			0.07	0.15		0.15			
		2.3									
		1.65	V _S =0.8V I _S =100mA								
I _{OFF}	OFF State Leakage Current (nSn), (Dn)	3.3	V _S =0.3 or 3V			±10		± 100			nA
I _{IN}	Input Leakage Current	0 - 3.6	V _{IN} = 0 to 3.6V			±0.1		± 1			μA
I _{CC}	Quiescent Supply Current (1)	1.65-3.6	V _{IN} =V _{CC} or GND			±0.05		±0.2		±1	μA

Note 1: Guaranteed by design

Note 2: $\Delta R_{ON} = R_{ON(MAX)} - R_{ON(MIN)}$

Note 3: Flatness is defined as the difference between the maximum and minimum value of on-resistance as measured over the specified analog signal ranges.

Table 6: AC Electrical Characteristics ($C_L = 35\text{pF}$, $R_L = 50\Omega$, $t_r = t_f \leq 5\text{ns}$)

Symbol	Parameter	Test Condition		Value						Unit	
		V_{CC} (V)		$T_A = 25^\circ\text{C}$			-40 to 85°C		-55 to 125°C		
				Min.	Typ.	Max.	Min.	Max.	Min.		Max.
t_{PLH} , t_{PHL}	Propagation Delay	1.65-1.95	$V_I = \text{OPEN}$		0.45						ns
		2.3-2.7			0.40						
		3.0-3.6			0.30						
t_{ON}	TURN-ON time	1.65-1.95	$V_S = 0.8\text{V}$		70						ns
		2.3-2.7	$V_S = 1.5\text{V}$		30	50	60				
		3.0-3.6	$V_S = 1.5\text{V}$		30	50	60				
t_{OFF}	TURN-OFF time	1.65-1.95	$V_S = 0.8\text{V}$		45						ns
		2.3-2.7	$V_S = 1.5\text{V}$		25	30	40				
		3.0-3.6	$V_S = 1.5\text{V}$		25	30	40				
t_D	Break Before Make Time Delay	1.65-1.95	$C_L = 35\text{pF}$								ns
		2.3-2.7	$R_L = 50\Omega$	2	15						
		3.0-3.6	$V_S = 1.5\text{V}$	2	15						
Q	Charge injection	1.65-1.95	$C_L = 100\text{pF}$		50						pC
		2.3-2.7	$R_L = 1\text{M}\Omega$		40						
		3.0-3.6	$V_{GEN} = 0\text{V}$ $R_{GEN} = 0\Omega$		35						

Table 7: Analog Switch Characteristics ($C_L = 5\text{pF}$, $R_L = 50\Omega$, $T_A = 25^\circ\text{C}$)

Symbol	Parameter	Test Condition		Value						Unit	
		V_{CC} (V)		$T_A = 25^\circ\text{C}$			-40 to 85°C		-55 to 125°C		
				Min.	Typ.	Max.	Min.	Max.	Min.		Max.
OIRR	Off Isolation (1)	1.65-3.6	$V_S = 1V_{RMS}$ $f = 100\text{KHz}$		-64						dB
Xtalk	Crosstalk	1.65-3.6	$V_S = 1V_{RMS}$ $f = 100\text{KHz}$		-54						dB
THD	Total Harmonic Distortion	2.3-3.6	$R_L = 600\Omega$ $V_{IN} = 2V_{PP}$ $f = 20\text{Hz to } 20\text{kHz}$		0.03						%
BW	-3dB Bandwidth	1.65-3.6	$R_L = 50\Omega$		50						MHz
C_{IN}	Control Pin Input Capacitance				5						pF
C_{Sn}	Sn Port Capacitance	3.3	$f = 1\text{MHz}$		37						
C_D	D Port Capacitance when Switch is Enabled	3.3	$f = 1\text{MHz}$		84						

Note 1: Off Isolation = $20\text{Log}_{10}(V_D/V_S)$, V_D = output. V_S = input to off switch

Figure 4: ON Resistance

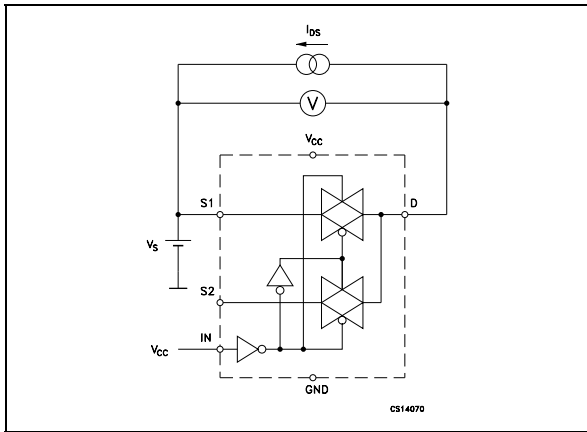

Figure 7: Bandwidth

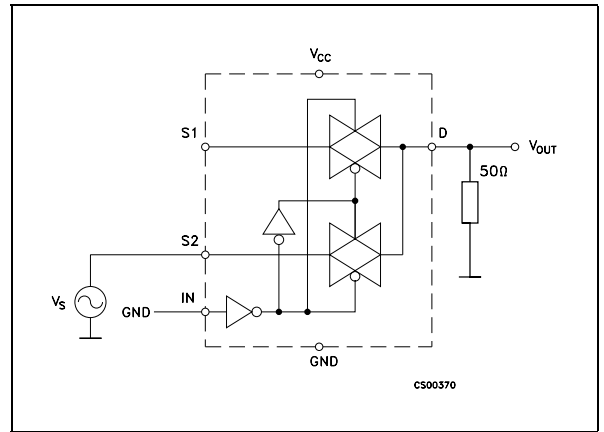

Figure 5: OFF Leakage

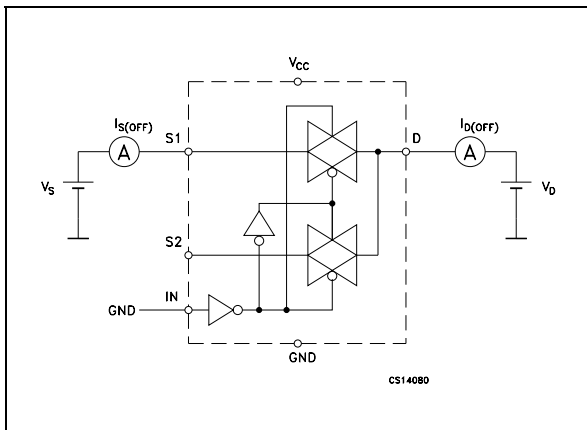

Figure 8: Channel To Channel Crosstalk

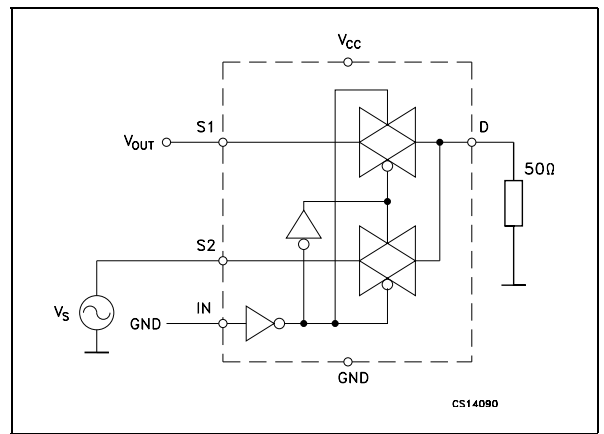

Figure 6: OFF Isolation

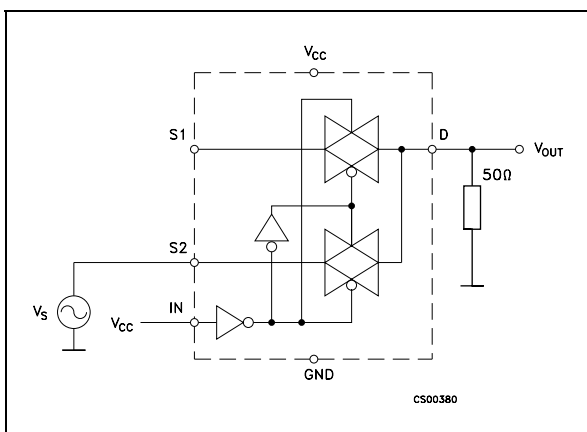
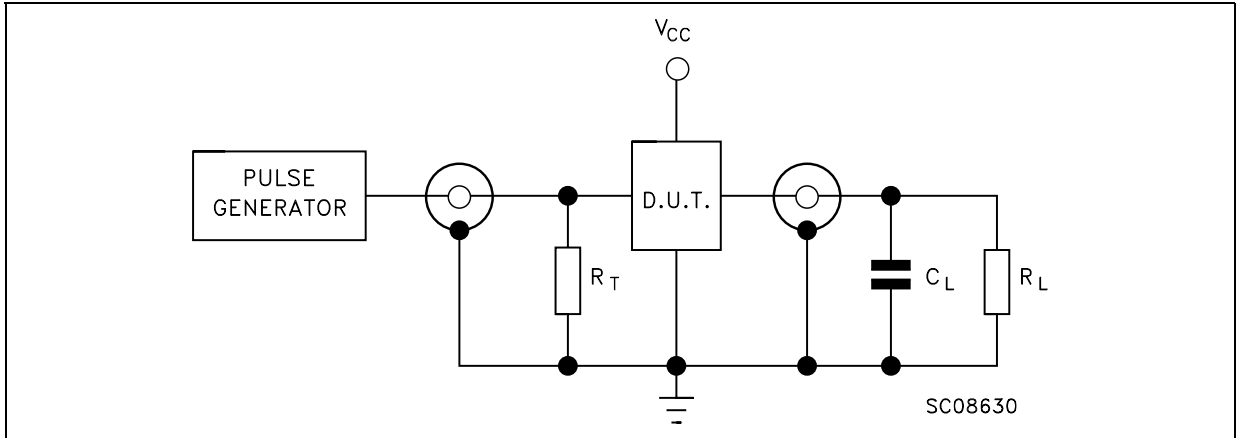

Figure 9: Test Circuit



$C_L = 5/35\text{pF}$ or equivalent (includes jig and probe capacitance)
 $R_L = 50\Omega$ or equivalent
 $R_T = Z_{OUT}$ of pulse generator (typically 50Ω)

Figure 10: Break Before Make Time Delay

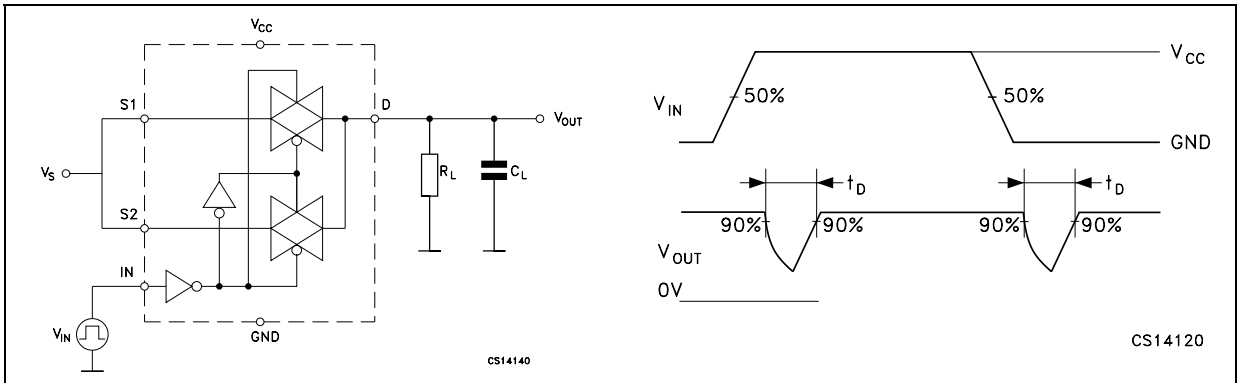

Figure 11: Switching Time And Charge Injection ($V_{GEN}=0V$, $R_{GEN}=0\Omega$, $R_L=1M\Omega$, $C_L=100\text{pF}$)

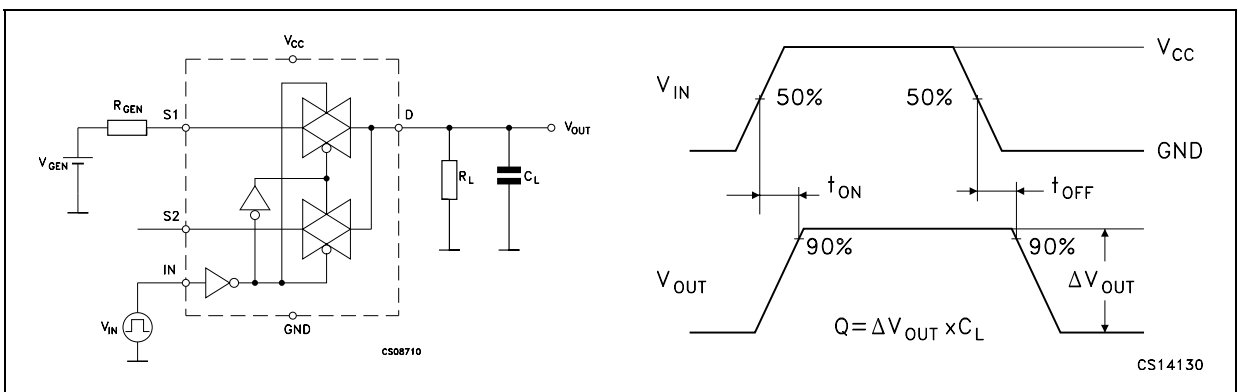
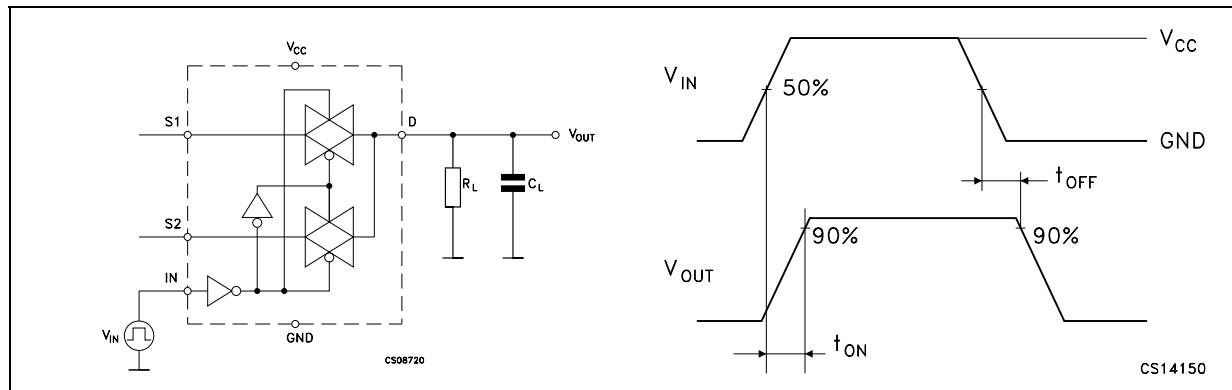
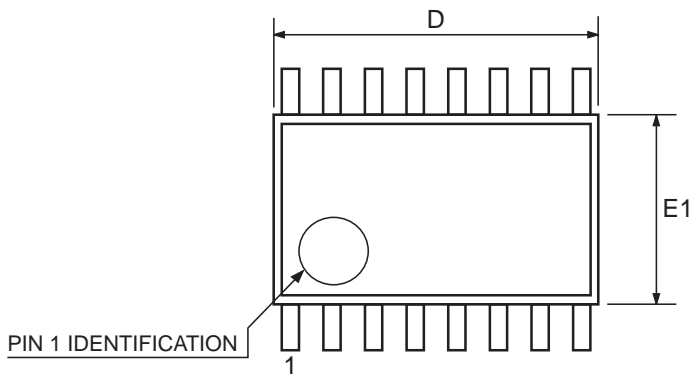
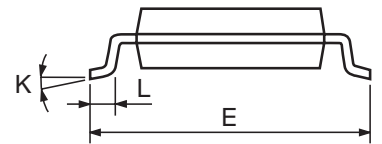
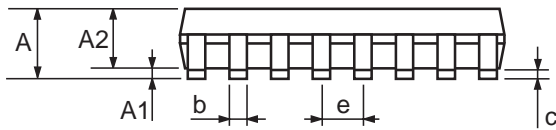

Figure 12: Turn ON, Turn OFF Delay Time



TSSOP16 MECHANICAL DATA

DIM.	mm.			inch		
	MIN.	TYP	MAX.	MIN.	TYP.	MAX.
A			1.2			0.047
A1	0.05		0.15	0.002	0.004	0.006
A2	0.8	1	1.05	0.031	0.039	0.041
b	0.19		0.30	0.007		0.012
c	0.09		0.20	0.004		0.0079
D	4.9	5	5.1	0.193	0.197	0.201
E	6.2	6.4	6.6	0.244	0.252	0.260
E1	4.3	4.4	4.48	0.169	0.173	0.176
e		0.65 BSC			0.0256 BSC	
K	0°		8°	0°		8°
L	0.45	0.60	0.75	0.018	0.024	0.030



0080338D

QFN16 (3x3) MECHANICAL DATA

DIM.	mm.			inch		
	MIN.	TYP	MAX.	MIN.	TYP.	MAX.
A	0.80	0.90	1.00	0.032	0.035	0.039
A1		0.02	0.05		0.001	0.002
A3		0.20			0.008	
b	0.18	0.25	0.30	0.007	0.010	0.012
D		3.00			0.118	
D2	1.55	1.70	1.80	0.061	0.067	0.071
E		3.00			0.118	
E2	1.55	1.70	1.80	0.061	0.067	0.071
e		0.50			0.020	
K		0.20			0.008	
L	0.30	0.40	0.50	0.012	0.016	0.020
r	0.09			0.006		

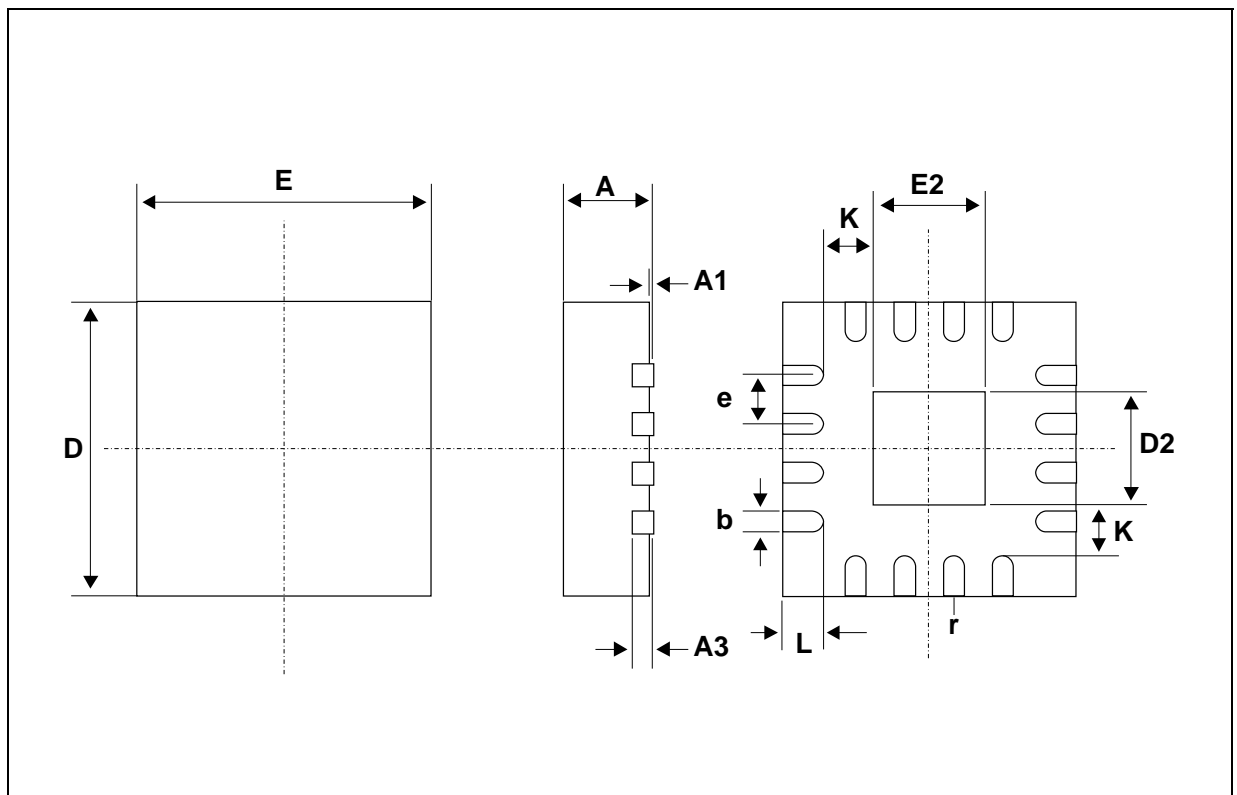

Tape & Reel TSSOP16 MECHANICAL DATA

DIM.	mm.			inch		
	MIN.	TYP	MAX.	MIN.	TYP.	MAX.
A			330			12.992
C	12.8		13.2	0.504		0.519
D	20.2			0.795		
N	60			2.362		
T			22.4			0.882
Ao	6.7		6.9	0.264		0.272
Bo	5.3		5.5	0.209		0.217
Ko	1.6		1.8	0.063		0.071
Po	3.9		4.1	0.153		0.161
P	7.9		8.1	0.311		0.319

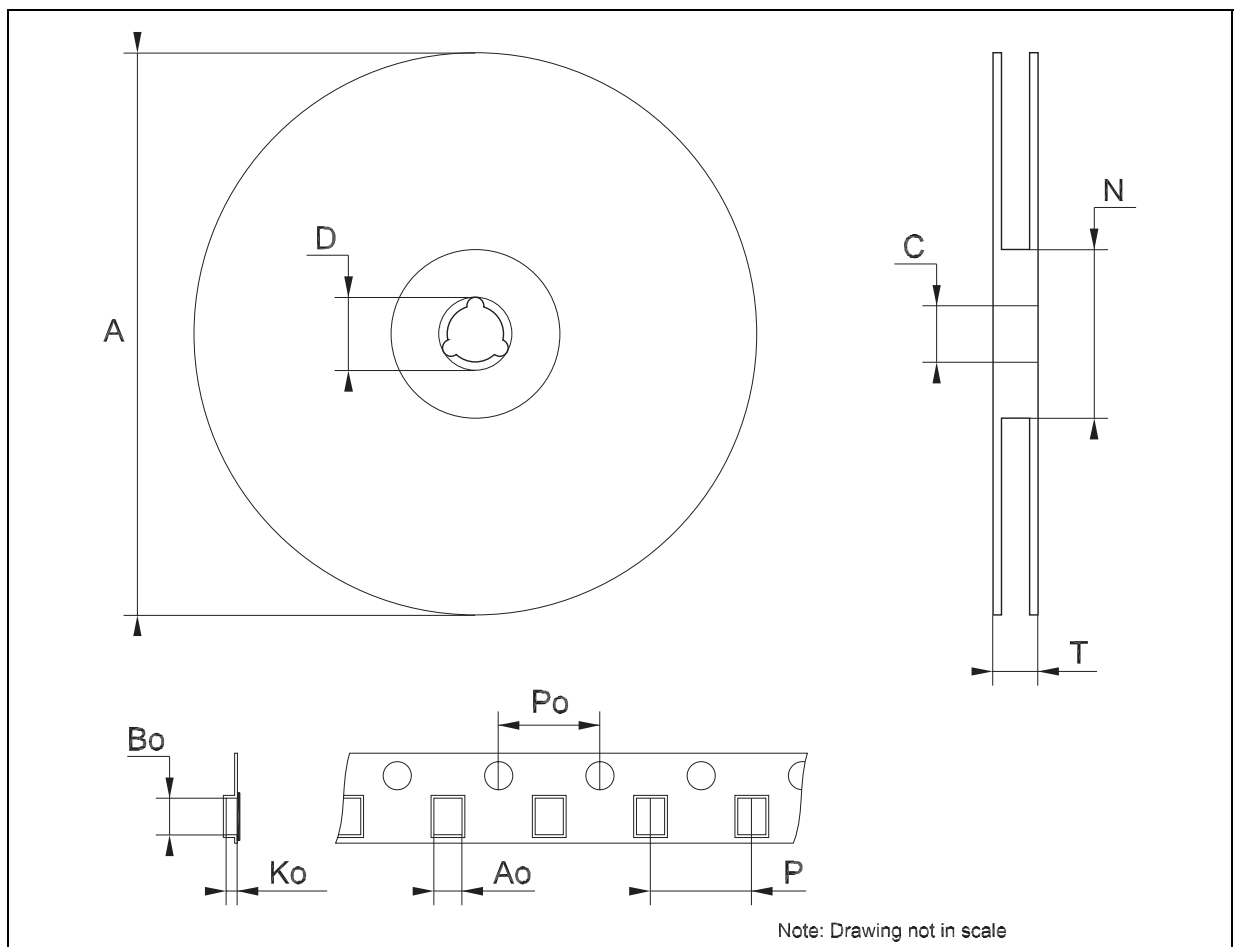

Table 8: Revision History

Date	Revision	Description of Changes
17-May-2005	2	The R _{ON} values are changed on Table 5.
04-Jul-2005	3	The Q Values on Table 6 has been updated.

Information furnished is believed to be accurate and reliable. However, STMicroelectronics assumes no responsibility for the consequences of use of such information nor for any infringement of patents or other rights of third parties which may result from its use. No license is granted by implication or otherwise under any patent or patent rights of STMicroelectronics. Specifications mentioned in this publication are subject to change without notice. This publication supersedes and replaces all information previously supplied. STMicroelectronics products are not authorized for use as critical components in life support devices or systems without express written approval of STMicroelectronics.

The ST logo is a registered trademark of STMicroelectronics

All other names are the property of their respective owners

© 2005 STMicroelectronics - All Rights Reserved

STMicroelectronics group of companies

Australia - Belgium - Brazil - Canada - China - Czech Republic - Finland - France - Germany - Hong Kong - India - Israel - Italy - Japan - Malaysia - Malta - Morocco - Singapore - Spain - Sweden - Switzerland - United Kingdom - United States of America

www.st.com