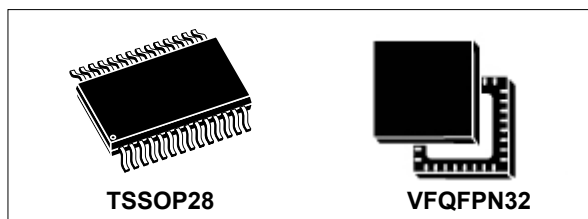

Flash-based TPM 2.0 device with an SPI interface

Data brief

**Features****TPM features**

- Flash based Trusted Platform Module (TPM)
- For TPM 2.0, compliant with Trusted Computing Group (TCG) Trusted Platform Module (TPM) Library specifications 2.0, Level 0, Revision 116 and TCG PC Client Specific TPM Platform Specifications 0.43 and errata
- TPM firmware code can be upgraded thanks to a persistent Application Flash Loader to support new standard evolutions
- CC certification according to TPM 2.0 PP at EAL4+
- SPI support at up to 33 MHz

Hardware features

- ARM® SecurCore® SC300™ 32-bit RISC core
- Highly reliable Flash memory technology
- Extended temperature ranges: -40 °C to 105 °C
- ESD protection up to 4 kV (HBM)
- 1.8 V or 3.3 V supply voltage range
- 28-lead thin shrink small outline and 32-lead very thin fine pitch quad flat pack ECOPACK® packages

Security features

- Active shield and environmental sensors
- Monitoring of environmental parameters (power)
- Hardware and software protection against fault injection
- FIPS compliant RNG built on an SP800-90A compliant SHA256 DRBG and an AIS-31 Class PTG2 compliant true random number generator (TRNG)
- Cryptographic algorithms:
 - RSA key generation (1024 or 2048 bits)
 - RSA signature and encryption
 - HMAC SHA-1 & SHA-256
 - AES-128-192-256
 - ECC 224 & 256 bits
 - ECDH 224 & 256 bits
 - ECDSA

Product compliance

- Compliant with Microsoft® Windows 8.1 and Windows 10
- Compliant with Intel® TXT for TPM 2.0
- Compliant with TCG test suite for TPM 2.0

Contents

- 1 Description 3**
 - 1.1 Security certifications 3
 - 1.2 Hardware features 3

- 2 Pin and signal descriptions 4**

- 3 Package information 6**
 - 3.1 28-pin thin shrink small outline package information 6
 - 3.2 32-lead very thin fine pitch quad flat pack no-lead (VFQFPN)
package information 8

- 4 Delivery packing 10**

- 5 Package marking information 13**

- 6 Support and information 14**

- Revision history 17**



1 Description

The ST33TPHF20SPI is a cost-effective and high performance trusted platform module (TPM) targeting PC, server platforms and embedded systems.

The product implements the functions defined by the Trusted Computing Group (www.trustedcomputinggroup.org) in the TCG Trusted Platform Module Library Specifications version 2.0 Level 0 Revision 116 ([\[TPM 2.0 P1 r116\]](#), [\[TPM 2.0 P2 r116\]](#), [\[TPM 2.0 P3 r116\]](#), [\[TPM 2.0 P4 r116\]](#)) and errata version 1.3 [\[TPM 2.0 rev116 Err 1.3\]](#). It is also based on the TCG PC Client specific TPM Platform specifications rev0.43 [\[PTP 2.0 r0.43\]](#) and [\[Errata sheet\]](#). [\[TPM 2.0 PP\]](#) specifies the protection profile.

The product also supports the ability to upgrade the TPM firmware thanks to a persistent application Flash loader to support new standard evolutions.

1.1 Security certifications

This product is CC certified according to TPM 2.0 PP at EAL4+. It also targets FIPS 140-2 certification.

1.2 Hardware features

The ST33TPHF20SPI is based on a smartcard-class secure MCU that incorporates the most recent generation of ARM[®] processors for embedded secure systems. Its SecurCore[®] SC300[™] 32-bit RISC core is built on the Cortex[®] M3 core with additional security features to help to protect against advanced forms of attacks.

The ST33TPHF20SPI offers a fast slave serial peripheral interface (SPI) supported by an embedded hardware communication engine compliant with TCG PC Client TPM Profile 0.43 [\[PTP 2.0 r0.43\]](#).

The product features hardware accelerators for advanced cryptographic functions. The AES peripheral provides a secure AES (Advanced Encryption Standard) algorithm implementation, while the NESCRYPT crypto-processor efficiently supports the public key algorithms.

The ST33TPHF20SPI operates in the -25 to +85 °C commercial temperature range or the -40 °C to 105 °C extended temperature range with a supply and I/O voltage of 1.8 V or 3.3 V.

In order to meet environmental requirements, ST offers these devices in different grades of ECOPACK[®] packages, depending on their level of environmental compliance. ECOPACK[®] specifications, grade definitions and device status are available at: www.st.com.

ECOPACK[®] is an ST trademark.



2 Pin and signal descriptions

Figure 1 and Figure 2 give the pinouts of the two packages in which the devices are delivered. Table 1 describes the associated signals.

Figure 1. TSSOP28 pinout

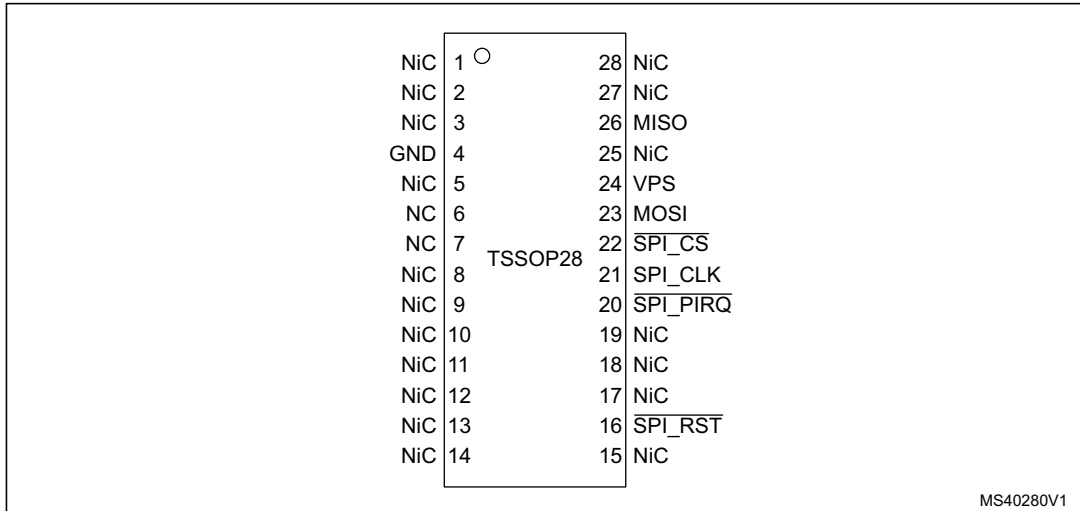

Figure 2. VQFN32 pinout

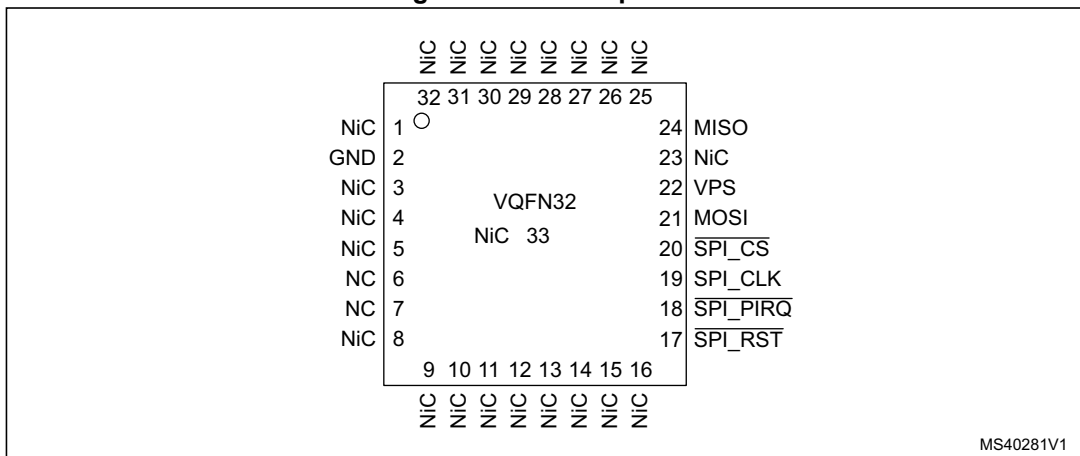

Table 1. Pin descriptions

Signal	Type	Description
VPS	Input	Power supply. This pin must be connected to 1.8 V or 3.3 V DC power rail supplied by the motherboard.
GND	Input	GND has to be connected to the main motherboard ground.
$\overline{\text{SPI_RST}}$	Input	SPI Reset used to re-initialize the device
MISO	Output	SPI Master Input, Slave Output (output from slave)
MOSI	Input	SPI Master Output, Slave Input (output from master)
SPI_CLK	Input	SPI Serial Clock (output from master)
$\overline{\text{SPI_CS}}$	Input	SPI Slave Select (active low; output from master)
$\overline{\text{SPI_PIRQ}}$	Output	SPI IRQ used by TPM to generate an interrupt
NiC	-	Not internally connected: not connected to the die. May be left unconnected but no impact on TPM if connected.
NC	-	Not Connected: connected to the die but not usable. May be left unconnected. Internal pull down.

Note: The VQFN32 package has an central pad (PIN33) on the bottom, which is not connected to the die. This pin does not impact the TPM, be it connected or not.

3 Package information

In order to meet environmental requirements, ST offers these devices in different grades of ECOPACK® packages, depending on their level of environmental compliance. ECOPACK® specifications, grade definitions and product status are available at: www.st.com. ECOPACK® is an ST trademark.

3.1 28-pin thin shrink small outline package information

Dimensional features of the TSSOP28 package: Body width 4.4 mm. Pitch 0.65 mm. Unless otherwise specified, general tolerance is ± 0.1 mm.

Figure 3. 28-lead thin shrink small outline package outline

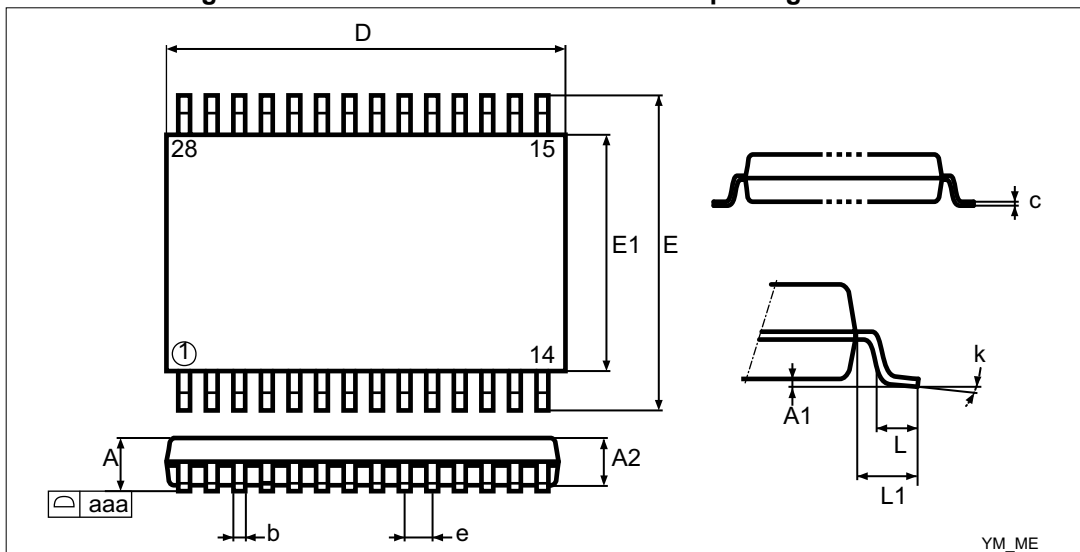

1. Drawing is not to scale.

Table 2. 28-lead thin shrink small outline package mechanical data

Symbol	millimeters			inches ⁽¹⁾		
	Min.	Typ.	Max.	Min.	Typ.	Max.
A	-	-	1.20	-	-	0.047
A1	0.05	-	0.15	0.002	-	0.006
A2	0.80	1.00	1.05	0.031	0.040	0.041
b	0.19	-	0.30	0.007	-	0.012
c	0.09	-	0.20	0.004	-	0.008
D	9.60	9.70	9.80	0.378	0.382	0.386
E	6.20	6.40	6.60	0.244	0.252	0.260
E1	4.30	4.40	4.50	0.170	0.173	0.177
e	-	0.65	-	-	0.026	-
L	0.45	0.60	0.75	0.018	0.024	0.0230
L1	-	1.00	-	-	0.040	-

Table 2. 28-lead thin shrink small outline package mechanical data (continued)

Symbol	millimeters			inches ⁽¹⁾		
	Min.	Typ.	Max.	Min.	Typ.	Max.
k	0°	-	8°	0°	-	8°
aaa	-	-	0.10	-	-	0.004

1. Values in inches are converted from mm and rounded to 4 decimal digits.

Figure 4. 28-lead thin shrink small outline package footprint

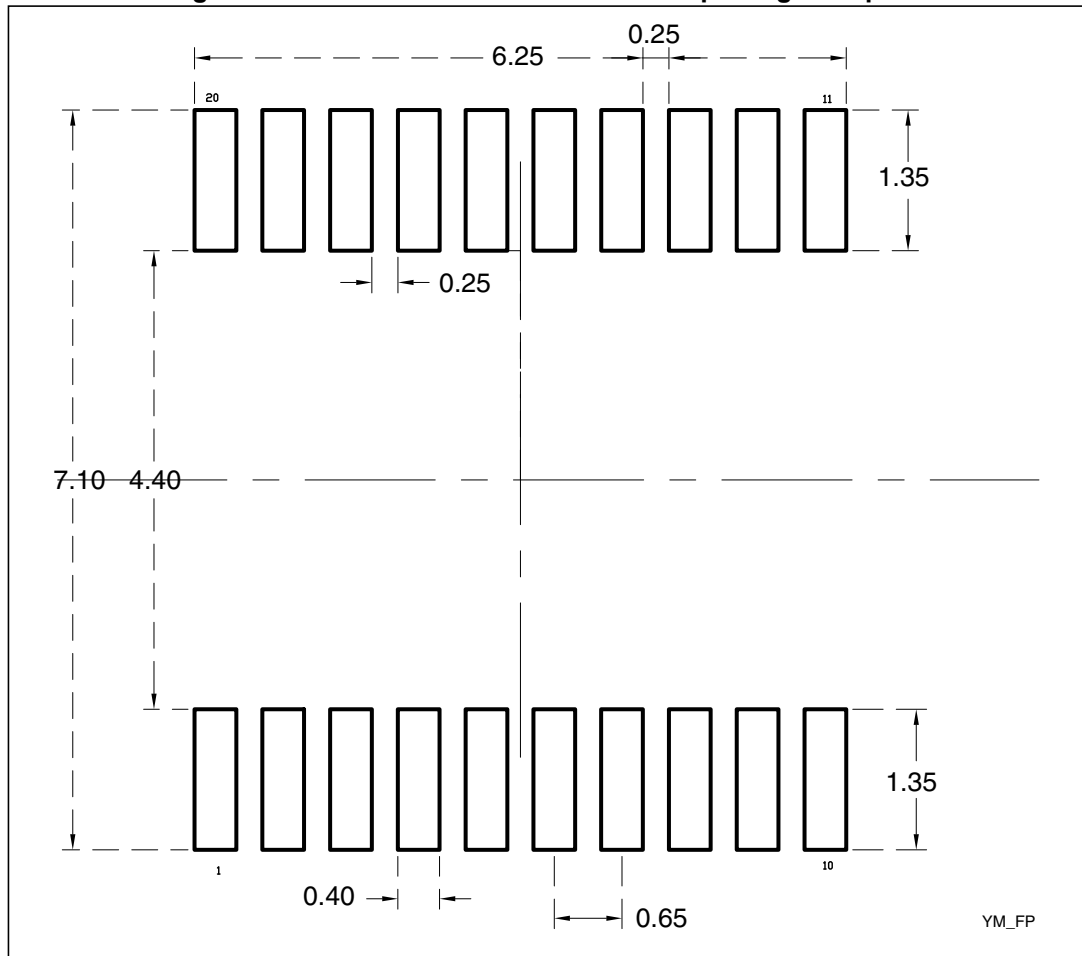

1. All dimensions are in millimeters.

3.2 32-lead very thin fine pitch quad flat pack no-lead (VFQFPN) package information

Figure 5. VFQFPN32 5x5 mm 0.5 mm pitch package outline

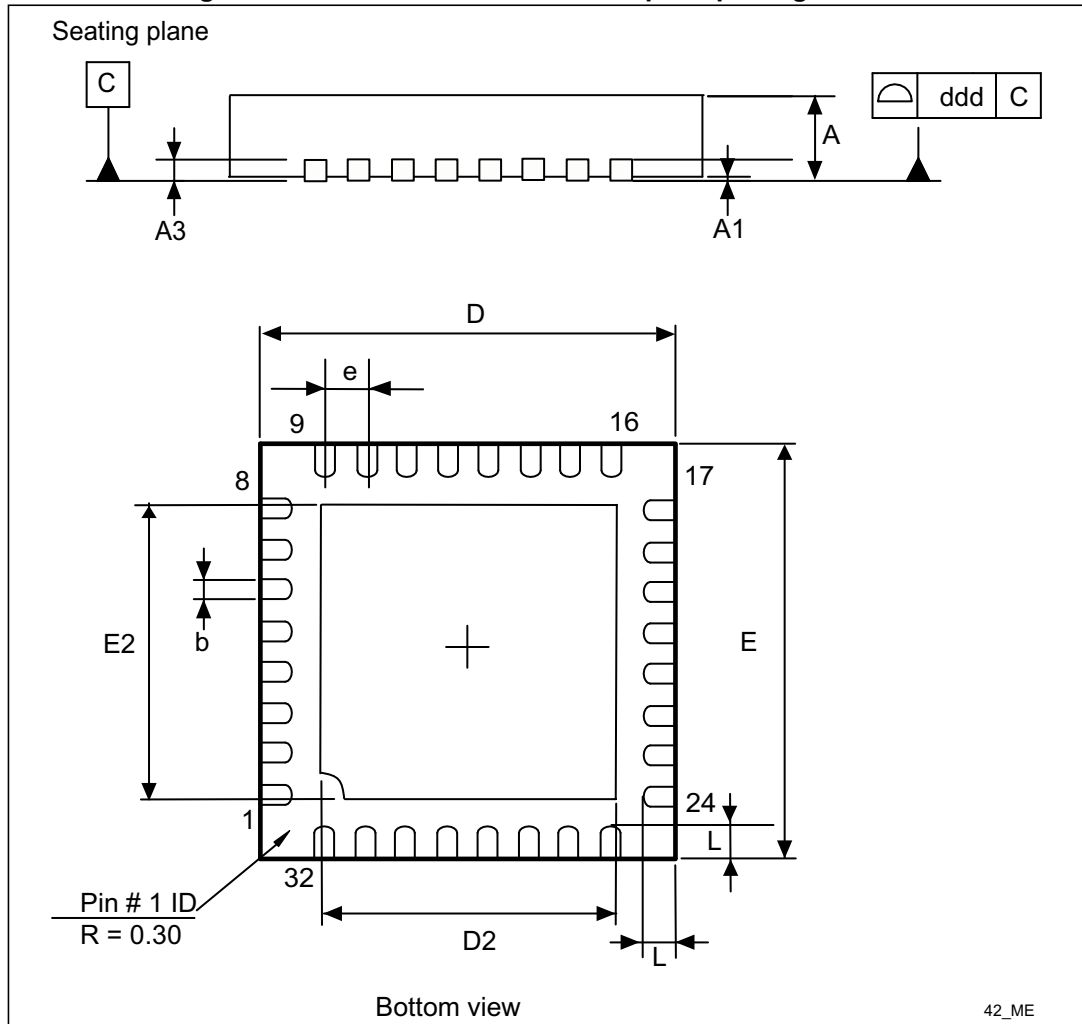

1. Drawing is not to scale.

Table 3. VFQFPN32 5x5 mm package mechanical data

Symbol	millimeters			inches ⁽¹⁾		
	Min.	Typ.	Max.	Min.	Typ.	Max.
A	0.800	0.900	1.000	0.0315	0.0354	0.0394
A1	0.000	0.020	0.050	0.0000	0.0008	0.0020
A3	-	0.200	-	-	0.0079	-
b	0.180	0.250	0.300	0.0071	0.0098	0.0118
D	4.850	5.000	5.150	0.1909	0.1969	0.2028
D2	3.500	3.600	3.700	0.1378	0.1417	0.1457

Table 3. VFQFPN32 5x5 mm package mechanical data (continued)

Symbol	millimeters			inches ⁽¹⁾		
	Min.	Typ.	Max.	Min.	Typ.	Max.
E	4.850	5.000	5.150	0.1909	0.1969	0.2028
E2	3.500	3.600	3.700	0.1378	0.1417	0.1457
e	-	0.500	-	-	0.0197	-
L	0.300	0.400	0.500	0.0118	0.0157	0.0197
ddd	-	-	0.050	-	-	0.0020

1. Values in inches are converted from mm and rounded to 4 decimal digits.

Figure 6. VFQFPN32 5x5 mm 0.5 mm pitch package footprint

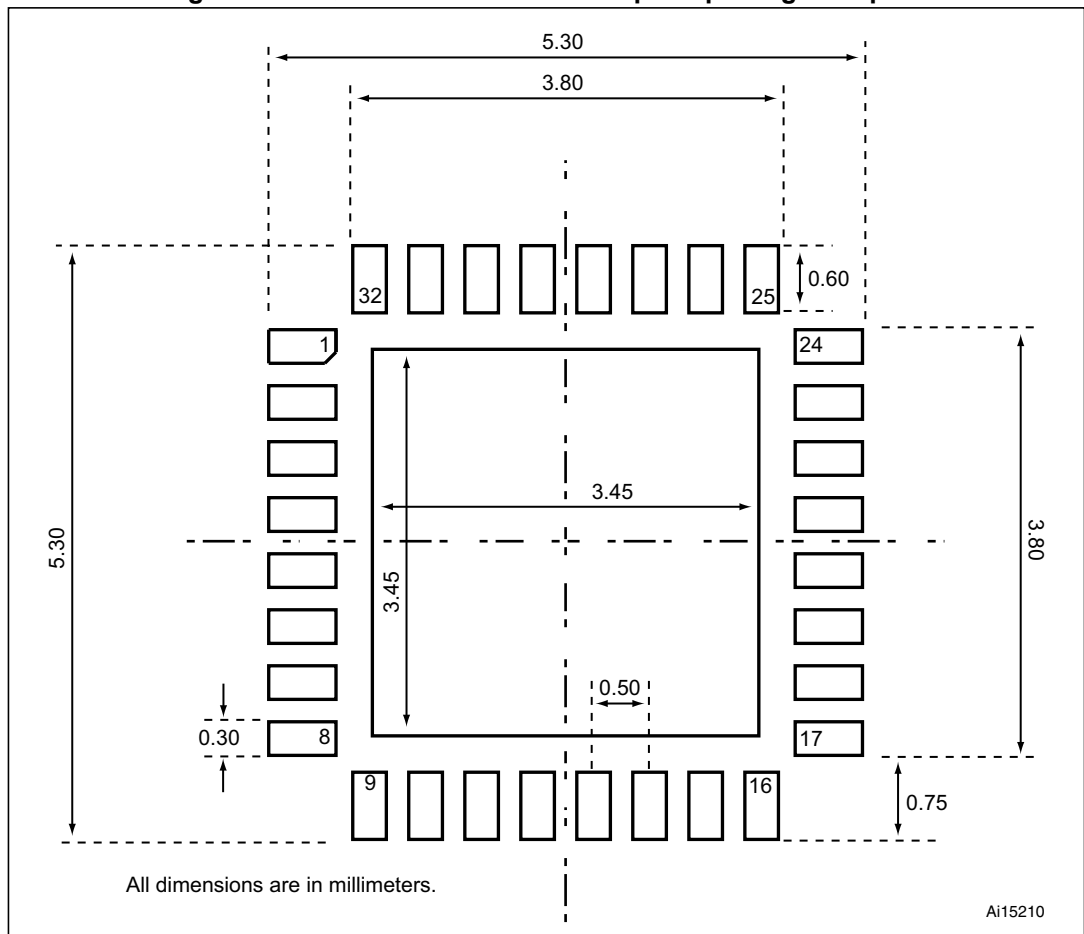

4 Delivery packing

Surface-mount packages can be supplied with Tape and Reel packing. The reels have a 13" typical diameter.

Reels are in plastic, either anti-static or conductive, with a black conductive cavity tape. The cover tape is transparent anti-static or conductive.

The devices are positioned in the cavities with the identifying pin (normally Pin "1") on the same side as the sprocket holes in the tape.

The STMicroelectronics Tape & Reel specifications are compliant to the EIA 481-A standard specification.

Table 4. Packages on tape and reel

Package	Description	Tape width	Tape pitch	Reel diameter	Quantity per reel
TSSOP 28	Thin shrink small outline package	16 mm	8 mm	13 in.	2500
VFQFPN 32	Very thin fine pitch quad flat pack no-lead package	12 mm	8 mm	13 in.	3000

Figure 7. Reel diagram

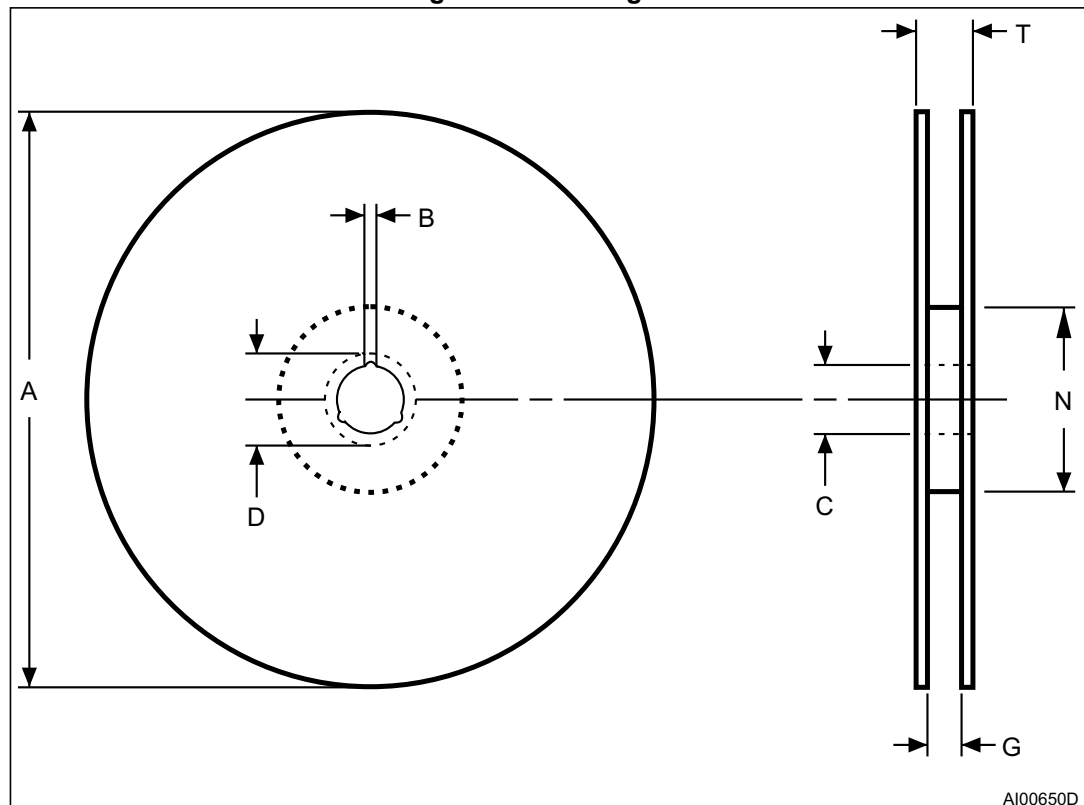

AI00650D

Table 5. Reel dimensions

Reel size	Tape width	A Max.	B Min.	C	D Min.	G Max.	N Min.	T Max.	Unit
13"	16	330	1.5	13 ±0.2	20.2	16.4 +2/-0	100	22.4	mm
	12					12.6		18.4	

Figure 8. Embossed carrier tape for VFQFPN 5 × 5 mm

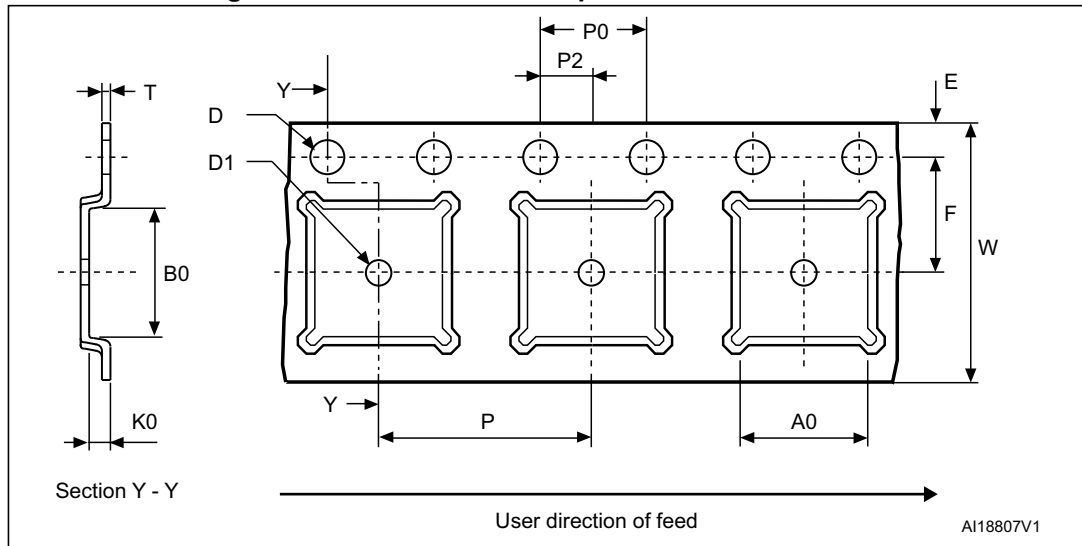

1. Drawing is not to scale.

Figure 9. Chip orientation in the embossed carrier tape for VFQFPN 5 × 5 mm

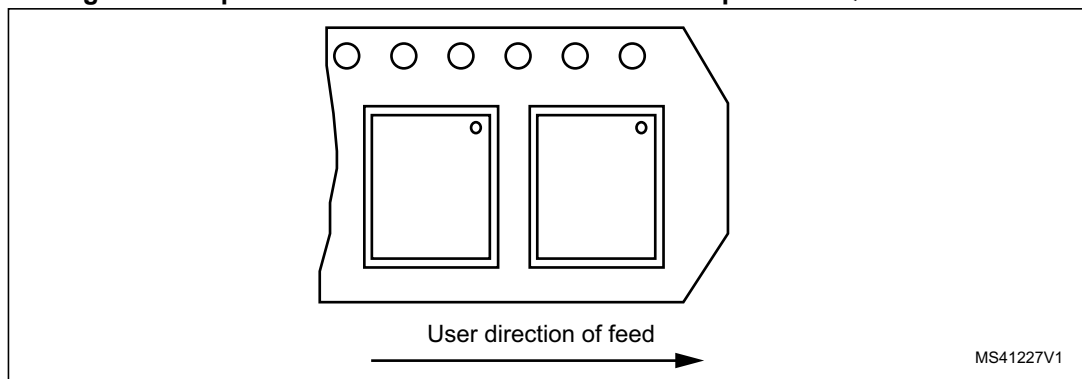
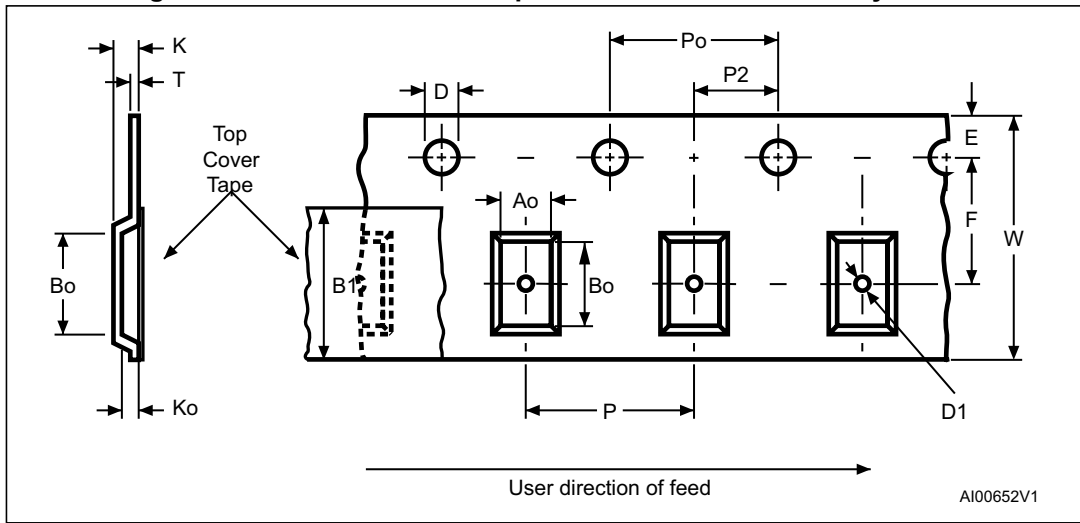

Table 6. Carrier tape dimensions for VFQFPN 5 × 5 mm

Package	A0	B0	K0	D1 Min.	P	P2	D	P0	E	F	W	T Max.	Unit
FPN 5x5	5.25 ±0.1	5.25 ±0.1	1.1 ±0.1	1.5	8 ±0.1	2 ±0.1	1.55 ±0.05	4 ±0.1	1.75 ±0.1	5.5 ±0.1	12 ±0.3	0.3 ±0.05	mm

Figure 10. Embossed carrier tape for TSSOP28 4.4 mm body width



1. Drawing is not to scale.

Figure 11. Chip orientation in the embossed carrier tape for TSSOP28 4.4 mm body width

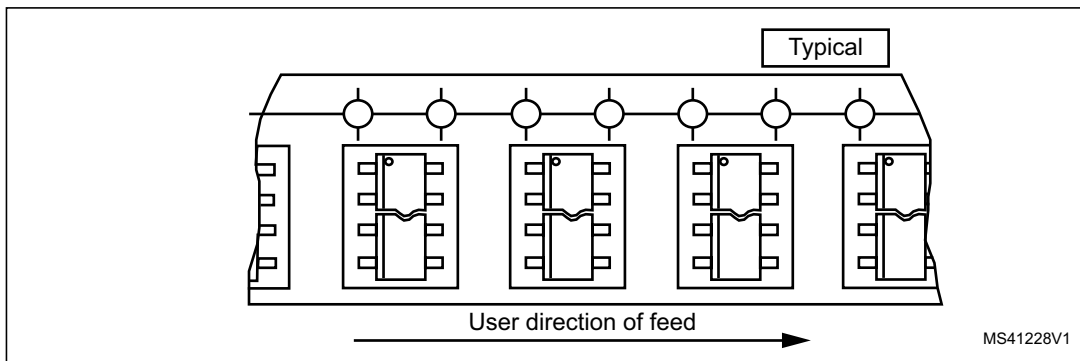

Table 7. Carrier tape constant dimensions for TSSOP 4.4 mm body width

Tape size	Ao, Bo, Ko ⁽¹⁾	D	E	Po	T Max.	Unit
16 mm	See note.	1.5 +0.1 / -0	1.75 ±0.1	4 ±0.1	0.4	mm

1. Ao, Bo, Ko, are determined by components sizes. The clearance between the component and the cavity must be within 0.05 mm (Min.) to 0.90 mm (Max.)

5 Package marking information

Figure 12 and Figure 13 illustrate the typical markings of the TSSOP28 and the VQFN32 device packages, respectively.

Figure 12. TSSOP28 device package marking area

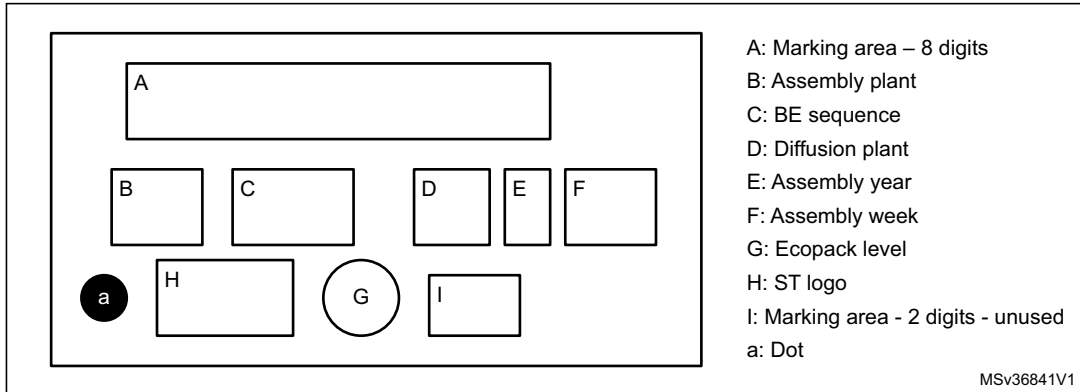
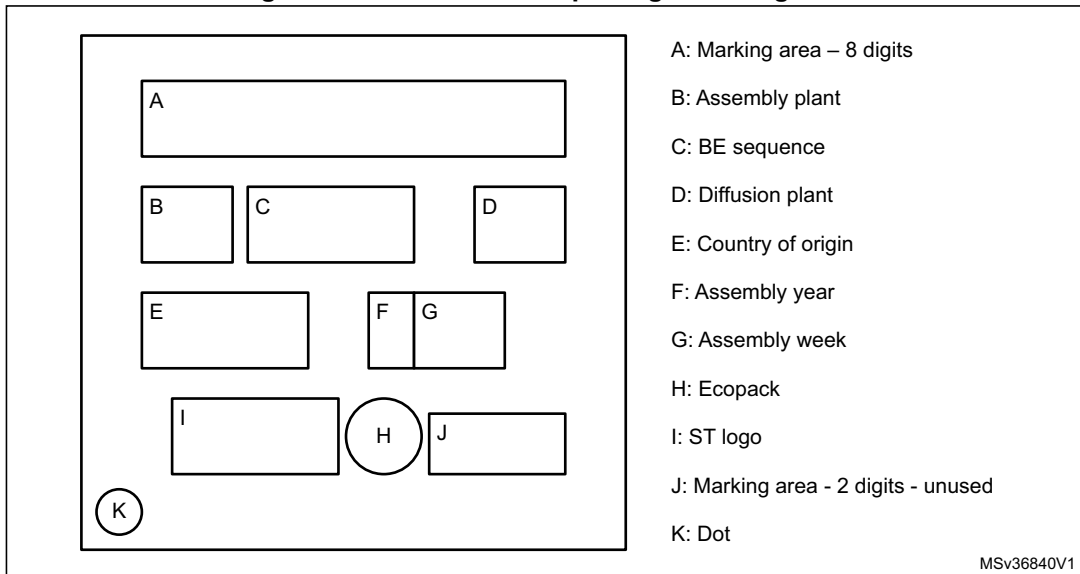

Figure 13. VQFN32 device package marking area



For both packages, the 8-digit 'A' marking area is equal to "P68XYZZZ" with:

- X = Hardware product
- Y = Hardware revision
- ZZZ = Firmware revision

6 Support and information

Additional information regarding ST TPM devices can be obtained from the website www.st.com.

For any specific support information you can contact STMicroelectronics through the following e-mail: TPMsupport@list.st.com.

Appendix A Terms and abbreviations

Table 8. List of abbreviations

Term	Meaning
AES	Advanced Encryption Standard
CA	Certificate authority
CC	Common Criteria
DAM	Dictionary attack mitigation mechanism
Data byte	Byte from the TPM command or answer or register value.
DES	Data Encryption Standard
EC	Elliptic Curve
EK	Endorsement Key
FIPS	Federal Information Processing Standard
GPIO	General Purpose I/O
HMAC	Keyed-Hashing for Message Authentication
HSM	Hardware security module
NIST	National Institute of Standards and Technology
NV	Non-volatile (memory)
OEM	Original Equipment Manufacturer
OIAP	Object-Independent Authorization Protocol
OSAP	Object Specific Authorization Protocol
PCR	Platform Configuration Register
RSA	Rivest Shamir Adelman
RTM	Root of Trust for Measurement
RTR	Root of Trust for Reporting
SHA	Secure Hash Algorithm
SPI	Serial Peripheral Interface
SRK	Storage Root Key
TCG	Trusted Computed Group
TIS	TPM interface specification
TPM	Trusted Platform Module
TPME	TPM Manufacturer
Transaction bytes	All bytes from a TPM command or TPM answer.
TSS	TPM Software Stack

Appendix B Referenced documents

The following materials are to be used in conjunction with or are referenced by this document.

[TPM 2.0 P1 r116]	TPM Library, Part 1, Architecture, Family 2.0, rev 1.16, TCG
[TPM 2.0 P2 r116]	TPM Library, Part 2, Structures, Family 2.0, rev 1.16, TCG
[TPM 2.0 P3 r116]	TPM Library, Part 3, Commands, Family 2.0, rev 1.16, TCG
[TPM 2.0 P4 r116]	TPM Library, Part 4, Supporting routines, Family 2.0, rev 1.16, TCG
[TPM 2.0 rev116 Err 1.3]	Errata version 1.3 June 16, 2015 for TCG TPM library version 2.0 revision 1.16 October 2014.
[PTP 2.0 r0.43]	TCG PC Client Specific Platform TPM Specification (PTP) - Version 2.0 Revision 0.43
[PKCS#1]	PKCS#1: v2.1 RSA Cryptography Standard, RSA Laboratories
[AN2639]	Application note, Soldering recommendations and package information for Lead-free ECOPACK® microcontrollers, STMicroelectronics
[Errata sheet]	PC_Client_Specific_Platform_TPM_Profile_for_TPM_2_0_errata_v1p0.pdf
[TCG EK Cre Profile TPM 2.0]	TCG EK credential profile for TPM Family 2.0 Level 0. Specification Version 2.0 Revision 14, November 4, 2014, TCG.
[TPM 20 PP]	Protection Profile PC Client Specific TPM, Family 2.0 Level 0 (1.0), December 2014, TCG.

Revision history

Table 9. Document revision history

Date	Revision	Changes
04-Mar-2016	1	Initial release.
15-Mar-2016	2	Updated <i>TPM features</i> related to certification and updated <i>Section 1.1: Security certifications</i> . Updated references in <i>Section 1: Description</i> . Added <i>Figure 9: Chip orientation in the embossed carrier tape for VFQFPN 5 × 5 mm</i> and <i>Figure 11: Chip orientation in the embossed carrier tape for TSSOP28 4.4 mm body width</i> .

IMPORTANT NOTICE – PLEASE READ CAREFULLY

STMicroelectronics NV and its subsidiaries (“ST”) reserve the right to make changes, corrections, enhancements, modifications, and improvements to ST products and/or to this document at any time without notice. Purchasers should obtain the latest relevant information on ST products before placing orders. ST products are sold pursuant to ST’s terms and conditions of sale in place at the time of order acknowledgement.

Purchasers are solely responsible for the choice, selection, and use of ST products and ST assumes no liability for application assistance or the design of Purchasers’ products.

No license, express or implied, to any intellectual property right is granted by ST herein.

Resale of ST products with provisions different from the information set forth herein shall void any warranty granted by ST for such product.

ST and the ST logo are trademarks of ST. All other product or service names are the property of their respective owners.

Information in this document supersedes and replaces information previously supplied in any prior versions of this document.

© 2016 STMicroelectronics – All rights reserved