

2-bit dual supply level translator without direction control pin, push-pull output

Datasheet –preliminary data

Features

- 45 MHz: 90 Mbps (max.) data rate at $V_L = 1.8\text{ V}$, $V_{CC} = 3.3\text{ V}$
- Bi-directional level translation without direction control pin
- Wide voltage range ($V_L \leq V_{CC}$):
 - V_L ranges from 1.65 to 3.6 V
 - V_{CC} ranges from V_L to 5.5 V
- Totem pole driving
- 5.5 V tolerant Enable pin
- ESD performance on all pins: $\pm 2\text{ kV HBM}$
- Small package and footprint
QFN8 1.4 x 1.2 x 0.55 mm

Applications

- Low-voltage system level translation
- Mobile phones and other mobile devices

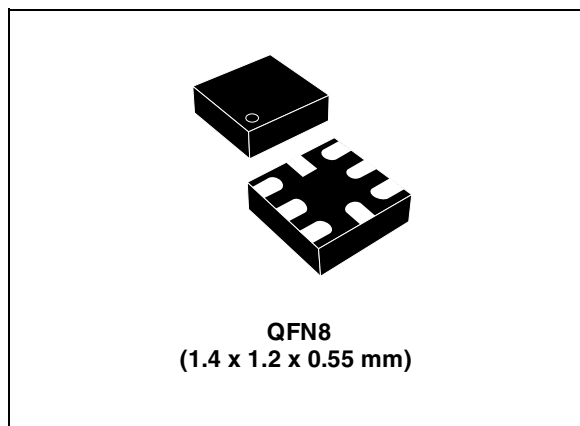

Table 1. Device summary

Order code	Package	Packing	Package topmark
ST2129BQTR	QFN8 (1.4 x 1.2 x 0.55 mm)	Tape and reel (3000 parts per reel)	1A

Contents

1	Description	5
2	Pin settings	6
	2.1 Pin connection	6
	2.2 Pin description	6
3	Logic diagram	7
	Device block diagrams	7
4	Supplementary notes	9
	4.1 Driver requirement	9
	4.2 Load driving capability	9
	4.3 Truth table	9
5	Maximum ratings	10
	Recommended operating conditions	10
6	Electrical characteristics	11
	6.1 DC characteristics	11
	6.2 AC characteristics	13
7	Test circuit	16
8	Package mechanical data	18
9	Revision history	20

List of tables

Table 1.	Device summary	1
Table 2.	Pin description	6
Table 3.	Truth table.	9
Table 4.	Absolute maximum ratings	10
Table 5.	Recommended operating conditions	10
Table 6.	DC characteristics	11
Table 7.	AC characteristics - test conditions: $V_L = 1.65 - 1.95 \text{ V}$	13
Table 8.	AC characteristics - test conditions: $V_L = 2.3 - 2.7 \text{ V}$	14
Table 9.	AC characteristics - test conditions: $V_L = 3.0 - 3.6 \text{ V}$	15
Table 10.	Test circuit switches	16
Table 11.	Waveform symbol value	16
Table 12.	Mechanical data for QFN8 (1.4 x 1.2 x 0.55 mm) - 0.40 mm pitch.	19
Table 13.	Document revision history	20

List of figures

Figure 1.	Pin connection (top through view)	6
Figure 2.	Logic block diagram	7
Figure 3.	ST2129BQTR block diagram	7
Figure 4.	Application block diagram	8
Figure 5.	Test circuit	16
Figure 6.	Waveform - propagation delay (f = 1 MHz, 50% duty cycle).	17
Figure 7.	Waveform - output enable and disable time (f = 1 MHz, 50% duty cycle)	17
Figure 8.	Package outline for QFN8 (1.4 x 1.2 x 0.55 mm) - 0.40 mm pitch	18
Figure 9.	Reel for carrier tape - 8 width	19

1 Description

The ST2129BQTR is a 2-bit dual supply level translator which provides the level shifting capability to allow data transfer in a multi-voltage system. Externally applied voltages, V_{CC} and V_L , set the logic levels on either side of the device. Its architecture allows bi-directional level translation without a control pin.

The ST2129BQTR accepts V_L from 1.65 to 3.6 V and V_{CC} from V_L to 5.5 V, making it ideal for data transfer between low-voltage ASICs/PLD and higher voltage systems. This device has a tri-state output mode which can be used to disable all I/Os.

2 Pin settings

2.1 Pin connection

Figure 1. Pin connection (top through view)

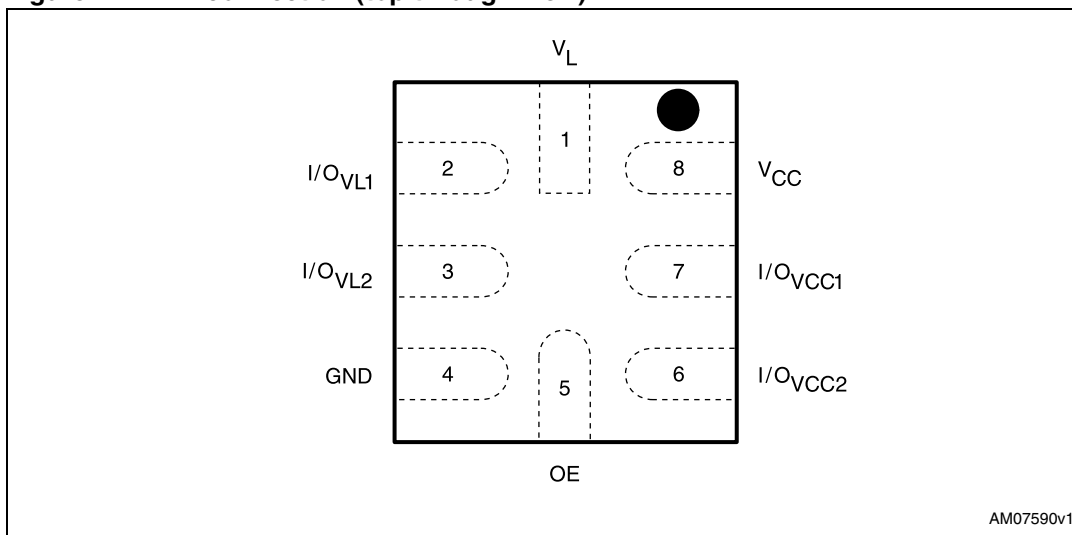

2.2 Pin description

Table 2. Pin description

Pin number	Symbol	Name and function
1	V_L	Supply voltage
2	I/O_{VL1}	Data input/output
3	I/O_{VL2}	Data input/output
4	GND	Ground
5	OE	Output enable
6	I/O_{VCC2}	Data input/output
7	I/O_{VCC1}	Data input/output
8	V_{CC}	Supply voltage

3 Logic diagram

Figure 2. Logic block diagram

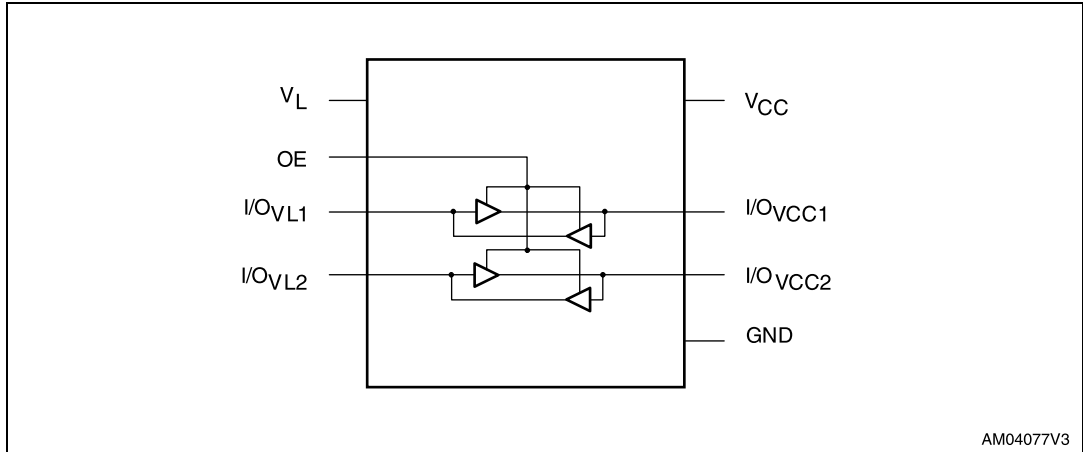

AM04077V3

Device block diagrams

Figure 3. ST2129BQTR block diagram

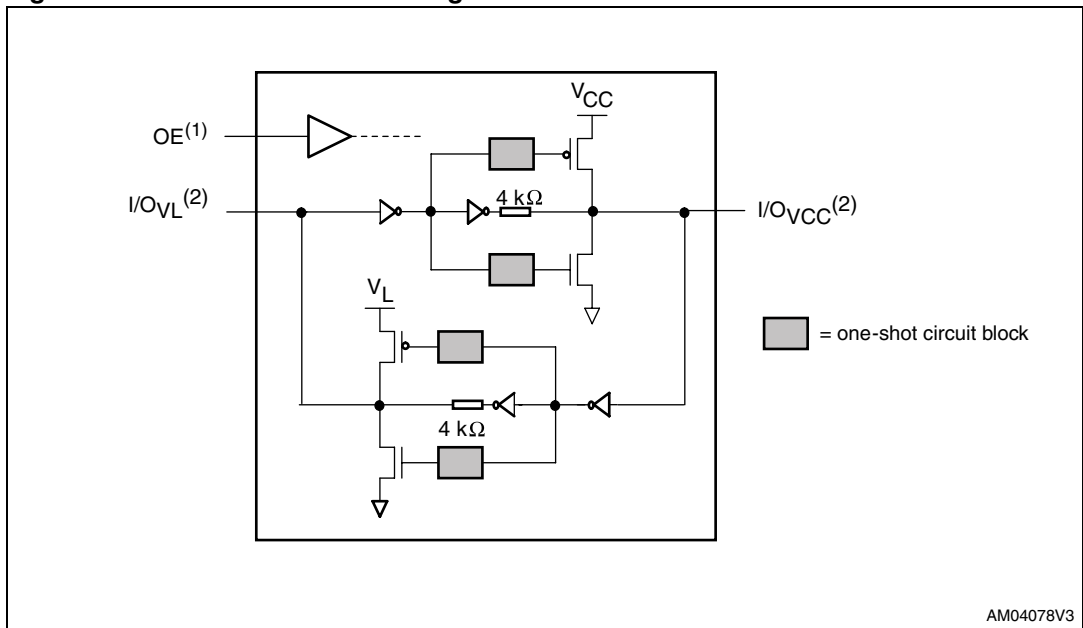

AM04078V3

1. When OE is LOW, all I/Os are in high-impedance mode.
2. ST2129BQTR has 2 channels. For simplicity, the above diagram shows only 1 channel.

Figure 4. Application block diagram

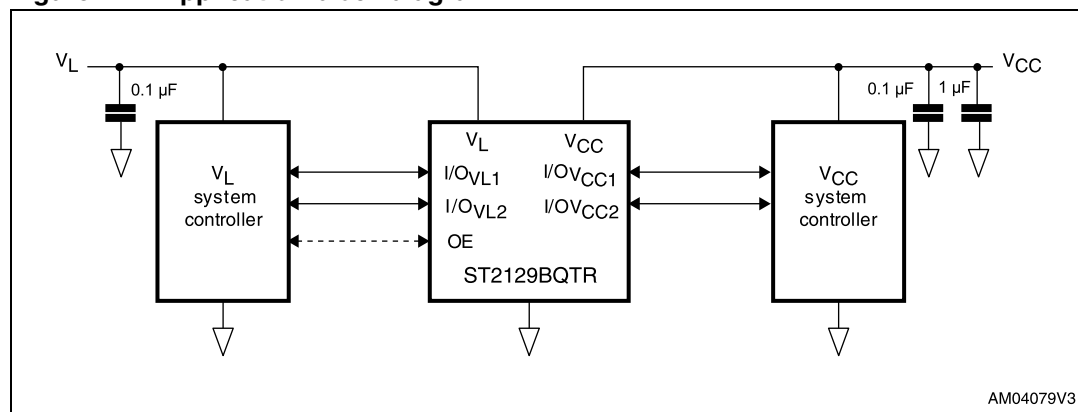

4 Supplementary notes

4.1 Driver requirement

For proper operation, the driver from each side of the device must have the capability to source and sink a minimum of 1 mA current. The device architecture requires the driver to source/sink maximum current of $(V_{CC}/4)$ mA to/from the weak 4 k Ω output buffer.

4.2 Load driving capability

To support the architecture that allows level translation without direction pin, the one-shot transistor is turned ON only during state transition at the output side. After the one-shot transistor is turned OFF, only the 4 k Ω resistor maintains the output logic state. So, a resistive load or pull-up resistor less than 50 k Ω is not recommended for proper operation.

4.3 Truth table

Table 3. Truth table

Enable	Bi-directional input/output	
OE	I/O _{VCC}	I/O _{VL}
H ⁽¹⁾	H ⁽²⁾	H ⁽¹⁾
H ⁽¹⁾	L	L
L	Z ⁽³⁾	Z ⁽³⁾

1. High level V_L power supply referred.
2. High level V_{CC} power supply referred.
3. Z = high impedance.

5 Maximum ratings

Stressing the device above the rating listed in [Table 4: Absolute maximum ratings](#) may cause permanent damage to the device. These are stress ratings only and operation of the device at these or any other conditions above those indicated in [Table 5: Recommended operating conditions](#) of this specification is not implied. Exposure to absolute maximum rating conditions for extended periods may affect device reliability.

Table 4. Absolute maximum ratings

Symbol	Parameter	Value	Unit
V _L	Supply voltage	-0.3 to 4.6	V
V _{CC}	Supply voltage	-0.3 to 6.5	V
V _{OE}	DC control input voltage	-0.3 to 6.5	V
V _{I/OVL}	DC I/O _{VL} input voltage (OE = GND or V _L)	-0.3 to V _L + 0.3	V
V _{I/OVCC}	DC I/O _{VCC} input voltage (OE = GND or V _L)	-0.3 to V _{CC} + 0.3	V
I _{IK}	DC input diode current	-20	mA
I _{I/OVL}	DC output current	±25	mA
I _{I/OVCC}	DC output current	±25	mA
I _{SC} TOUT	Short-circuit duration, continuous	40	mA
P _D	Power dissipation	500	mW
T _{STG}	Storage temperature	-65 to 150	°C
T _L	Lead temperature (10 seconds)	300	°C
ESD	Electrostatic discharge protection (HBM)	±2	kV

Recommended operating conditions

Table 5. Recommended operating conditions

Symbol	Parameter	Min.	Typ.	Max.	Unit
V _L	Supply voltage	1.65	–	3.6	V
V _{CC}	Supply voltage	V _L	–	5.5	V
V _{OE}	Input voltage (OE output enable pin, V _L power supply referred)	0	–	3.6	V
V _{I/OVL}	I/O _{VL} voltage	0	–	V _L	V
V _{I/OVCC}	I/O _{VCC} voltage	0	–	V _{CC}	V
T _{OP}	Operating temperature	-40	–	85	°C
dt/dV	Input rise and fall time	0	–	1	ns/V

6 Electrical characteristics

6.1 DC characteristics

Over recommended operating conditions unless otherwise noted. All typical values are at $T_A = 25\text{ }^\circ\text{C}$.

Table 6. DC characteristics

Symbol	Parameter	V_L	V_{CC}	Test conditions	Value					Unit
					$T_A = 25\text{ }^\circ\text{C}$			-40 to 85 $^\circ\text{C}$		
					Min.	Typ.	Max.	Min.	Max.	
V_{IHL}	High-level input voltage (I/O V_L)	1.65 to 3.6	V_L to 5.5		$0.8 V_L$	–	–	$0.8 V_L$	–	V
V_{ILL}	Low-level input voltage (I/O V_L)	1.65 to 3.6	V_L to 5.5		–	–	$0.2 V_L$	–	$0.2 V_L$	V
V_{IHC}	High-level input voltage (I/O V_{CC})	1.65 to 3.6	V_L to 5.5		$0.8 V_{CC}$	–	–	$0.8 V_{CC}$	–	V
V_{ILC}	Low-level input voltage (I/O V_{CC})	1.65 to 3.6	V_L to 5.5		–	–	$0.2 V_{CC}$	–	$0.2 V_{CC}$	V
V_{IH-OE}	High-level input voltage (OE)	1.65 to 3.6	V_L to 5.5		$0.8 V_L$	–	–	$0.8 V_L$	–	V
V_{IL-OE}	Low-level input voltage (OE)	1.65 to 3.6	V_L to 5.5		–	–	$0.2 V_L$	–	$0.2 V_L$	V
V_{OHL}	High-level output voltage (I/O V_L)	1.65 to 3.6	V_L to 5.5	IO = -60 μA	$V_L - 0.4$	–	–	$V_L - 0.4$	–	V
V_{OLL}	Low-level output voltage (I/O V_L)	1.65 to 3.6	V_L to 5.5	IO = +60 μA	–	–	0.4	–	0.4	V
V_{OHC}	High-level output voltage (I/O V_{CC})	1.65 to 3.6	V_L to 5.5	IO = -60 μA	$V_{CC} - 0.4$	–	–	$V_{CC} - 0.4$	–	V

Table 6. DC characteristics (continued)

Symbol	Parameter	V _L	V _{CC}	Test conditions	Value					Unit
					T _A = 25 °C			-40 to 85 °C		
					Min.	Typ.	Max.	Min.	Max.	
V _{OLC}	Low-level output voltage (I/O _{VCC})	1.65 to 3.6	V _L to 5.5	I _O = +60 μA	–	–	0.4	–	0.4	V
I _{OE}	Control input leakage current (OE)	1.65 to 3.6	V _L to 5.5	V _I = GND or V _L	–	–	0.1	–	1	μA
I _{IO_LKG}	High-impedance leakage current (I/O _{VL} , I/O _{VCC})	1.65 to 3.6	V _L to 5.5	OE = GND I/O _{VL} = high I/O _{VCC} = low	–	–	0.1	–	1	μA
				OE = GND I/O _{VL} = low I/O _{VCC} = high	–	–	0.1	–	1	μA
I _{QVCC}	Quiescent supply current V _{CC}	1.65 to 3.6	V _L to 5.5	OE = V _L	–	–	3.5	–	4.5	μA
I _{QVL}	Quiescent supply current V _L	1.65 to 3.6	V _L to 5.5	OE = V _L	–	–	0.1	–	1	μA
I _{Z-VCC}	High-impedance quiescent supply current V _{CC}	1.65 to 3.6	V _L to 5.5	OE = GND I/O = Hi-Z	–	–	0.1	–	1	μA
I _{Z-VL}	High-impedance quiescent supply current V _L	1.65 to 3.6	V _L to 5.5	OE = GND I/O = Hi-Z	–	–	0.1	–	1	μA

6.2 AC characteristics

Load $C_L = 15$ pF; driver $t_r = t_f \leq 6$ ns over temperature range -40 °C to 85 °C.

Table 7. AC characteristics - test conditions: $V_L = 1.65 - 1.95$ V

Symbol	Parameter	$V_{CC} = V_L - 1.95$ V		$V_{CC} = 2.3 - 2.7$ V		$V_{CC} = 3.0 - 3.6$ V		$V_{CC} = 4.5 - 5.5$ V		Unit	
		Min.	Max.	Min.	Max.	Min.	Max.	Min.	Max.		
t_{RVCC}	Rise time I/O_{VCC}	-	5.2	-	3.2	-	2.4	-	1.8	ns	
t_{FVCC}	Fall time I/O_{VCC}	-	3.2	-	1.5	-	1.3	-	1.2	ns	
t_{RVL}	Rise time I/O_{VL}	-	3.3	-	3.3	-	3.3	-	3.3	ns	
t_{FVL}	Fall time I/O_{VL}	-	1.5	-	1.4	-	1.4	-	1.3	ns	
$t_{I/OVL-VCC}$	Propagation delay time										
	I/O_{VL-LH} to I/O_{VCC-LH}	t_{PLH}	-	7.6	-	5.8	-	5.0	-	4.4	ns
	I/O_{VL-HL} to I/O_{VCC-HL}	t_{PHL}	-	4.6	-	3.9	-	3.9	-	3.5	ns
$t_{I/OVCC-VL}$	Propagation delay time										
	I/O_{VCC-LH} to I/O_{VL-LH}	t_{PLH}	-	7.1	-	6.6	-	4.8	-	4.6	ns
	I/O_{VCC-HL} to I/O_{VL-HL}	t_{PHL}	-	5.3	-	5.1	-	4.3	-	4.1	ns
t_{PZL}	Output enable time t_{PZL}	-	28	-	28	-	28	-	28	ns	
t_{PZH}	Output enable time t_{PZH}	-	90	-	90	-	90	-	90	ns	
t_{PLZ}	Output disable time t_{PLZ}		120	-	120	-	120	-	120	ns	
t_{PHZ}	Output disable time t_{PHZ}		80	-	60	-	50	-	50	ns	
D_R	Data rate ⁽¹⁾	56	-	90	-	90	-	90	-	Mbps	

1. Data rate is guaranteed based on the condition that output I/O signal rise/fall time is less than 15% of period of input I/O signal; input I/O signal is at 50% duty cycle and output I/O signal duty cycle deviation is less than $50\% \pm 10\%$.

Table 8. AC characteristics - test conditions: $V_L = 2.3 - 2.7 V$

Symbol	Parameter		$V_{CC} = V_L - 2.7 V$		$V_{CC} = 3.0 - 3.6 V$		$V_{CC} = 4.5 - 5.5 V$		Unit	
			Min.	Max.	Min.	Max.	Min.	Max.		
t_{RVCC}	Rise time I/O_{VCC}		-	3.3	-	2.2	-	1.7	ns	
t_{FVCC}	Fall time I/O_{VCC}		-	1.7	-	1.6	-	1.4	ns	
t_{RVL}	Rise time I/O_{VL}		-	2.2	-	2.2	-	1.9	ns	
t_{FVL}	Fall time I/O_{VL}		-	1.3	-	1.2	-	1.2	ns	
$t_{I/OVL-VCC}$	Propagation delay time									
	I/O_{VL-LH} to I/O_{VCC-LH}		t_{PLH}	-	4.8	-	4.3	-	3.9	ns
	I/O_{VL-HL} to I/O_{VCC-HL}		t_{PHL}	-	3.7	-	3.3	-	2.9	ns
$t_{I/OVCC-VL}$	Propagation delay time									
	I/O_{VCC-LH} to I/O_{VL-LH}		t_{PLH}	-	3.9	-	3.5	-	3.5	ns
	I/O_{VCC-HL} to I/O_{VL-HL}		t_{PHL}	-	3.6	-	3.5	-	3.4	ns
t_{PZL}	Output enable time t_{PZL}		-	25	-	25	-	25	ns	
t_{PZH}	Output enable time t_{PZH}		-	100	-	100	-	70	ns	
t_{PLZ}	Output disable time t_{PLZ}		-	90	-	90	-	90	ns	
t_{PHZ}	Output disable time t_{PHZ}		-	50	-	50	-	50	ns	
D_R	Data rate ⁽¹⁾		90	-	136	-	158	-	Mbps	

1. Data rate is guaranteed based on the condition that output I/O signal rise/fall time is less than 15% of period of input I/O signal; input I/O signal is at 50% duty cycle and output I/O signal duty cycle deviation is less than $50\% \pm 10\%$.

Table 9. AC characteristics - test conditions: $V_L = 3.0 - 3.6 V$

Symbol	Parameter		$V_{CC} = V_L - 3.6 V$		$V_{CC} = 4.5 - 5.5 V$		Unit	
			Min.	Max.	Min.	Max.		
$t_{RV_{CC}}$	Rise time $I/O_{V_{CC}}$		-	2.1	-	1.7	ns	
$t_{FV_{CC}}$	Fall time $I/O_{V_{CC}}$		-	1.3	-	1.3	ns	
t_{RV_L}	Rise time I/O_{V_L}		-	1.6	-	1.5	ns	
t_{FV_L}	Fall time I/O_{V_L}		-	1.1	-	1.1	ns	
$t_{I/O_{V_L-V_{CC}}}$	Propagation delay time							
	I/O_{V_L-LH} to $I/O_{V_{CC-LH}}$		t_{PLH}	-	4.1	-	4.1	ns
	I/O_{V_L-HL} to $I/O_{V_{CC-HL}}$		t_{PHL}	-	2.9	-	2.6	ns
$t_{I/O_{V_{CC-V_L}}}$	Propagation delay time							
	$I/O_{V_{CC-LH}}$ to I/O_{V_L-LH}		t_{PLH}	-	4.0	-	4.0	ns
	$I/O_{V_{CC-HL}}$ to I/O_{V_L-HL}		t_{PHL}	-	2.6	-	2.5	ns
t_{PZL}	Output enable time t_{PZL}		-	15	-	15	ns	
t_{PZH}	Output enable time t_{PZH}		-	70	-	15	ns	
t_{PLZ}	Output disable time t_{PLZ}		-	70	-	70	ns	
t_{PHZ}	Output disable time t_{PHZ}		-	50	-	50	ns	
D_R	Data rate ⁽¹⁾		144	-	186	-	Mbps	

1. Data rate is guaranteed based on the condition that output I/O signal rise/fall time is less than 15% of period of input I/O signal; input I/O signal is at 50% duty cycle and output I/O signal duty cycle deviation is less than $50\% \pm 10\%$.

7 Test circuit

Figure 5. Test circuit

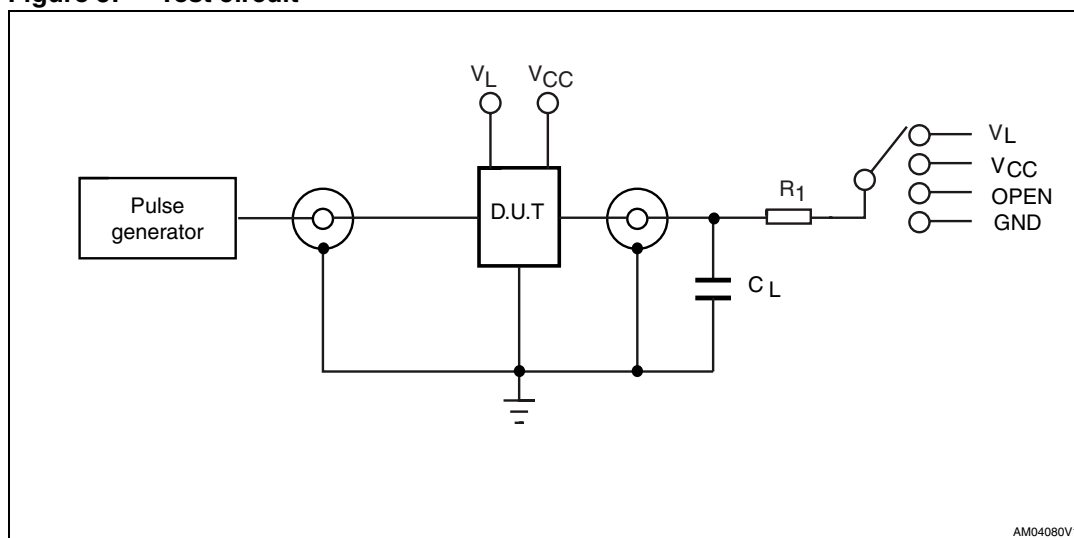

Table 10. Test circuit switches

Test	C_L	R_1	Switch
t_{PLH} , t_{PHL}	15 pF	20 k Ω	Open
t_r , t_f	15 pF	20 k Ω	Open
t_{PZL} , t_{PLZ}	15 pF	20 k Ω	V_L or V_{CC}
t_{PZH} , t_{PHZ}	15 pF	20 k Ω	GND

Table 11. Waveform symbol value

Symbol	Driving I/O V_L		Driving I/O V_{CC}	
	$1.65\text{ V} \leq V_L \leq V_{CC} \leq 2.5\text{ V}$	$3.3\text{ V} \leq V_L \leq V_{CC} \leq 5.5\text{ V}$	$1.65\text{ V} \leq V_L \leq V_{CC} \leq 2.5\text{ V}$	$3.3\text{ V} \leq V_L \leq V_{CC} \leq 5.5\text{ V}$
V_{IH}	V_L	V_L	V_{CC}	V_{CC}
V_{IM}	50% V_L	50% V_L	50% V_{CC}	50% V_{CC}
V_{OM}	50% V_{CC}	50% V_{CC}	50% V_L	50% V_L

Figure 6. Waveform - propagation delay (f = 1 MHz, 50% duty cycle)

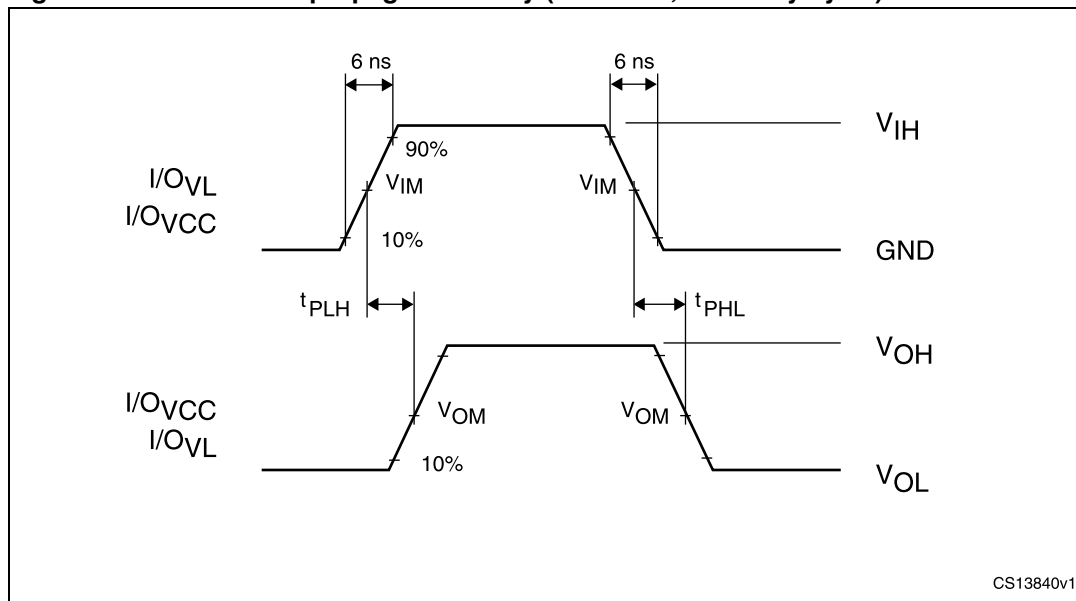
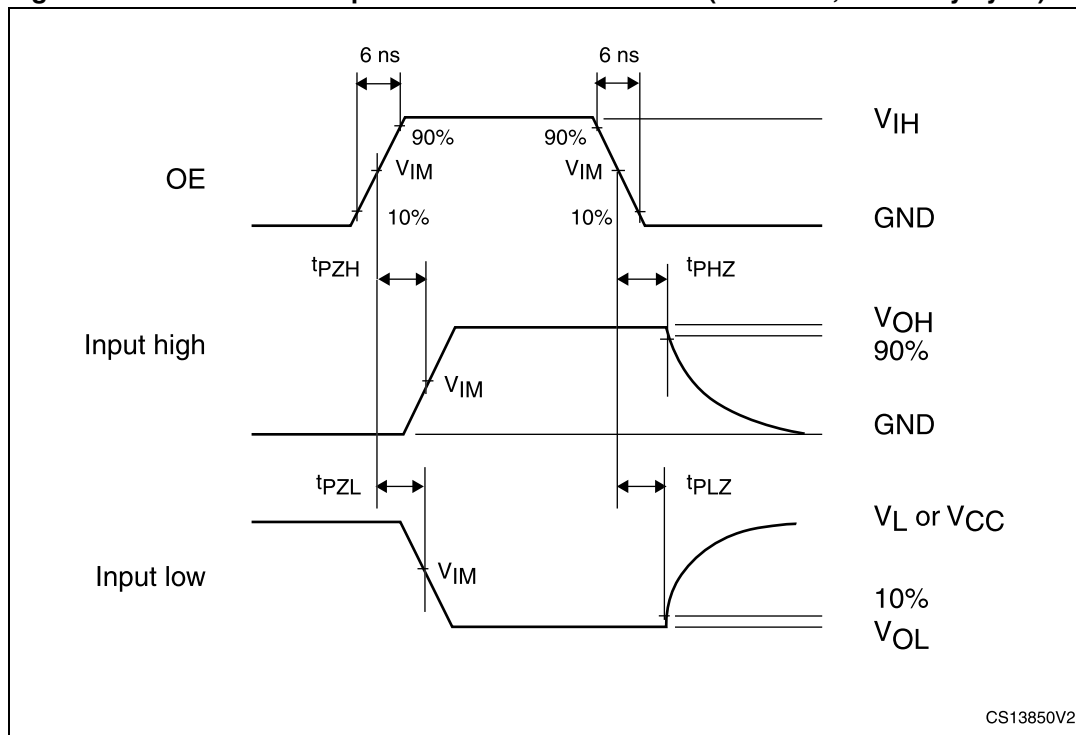

Figure 7. Waveform - output enable and disable time (f = 1 MHz, 50% duty cycle)



8 Package mechanical data

In order to meet environmental requirements, ST offers these devices in different grades of ECOPACK® packages, depending on their level of environmental compliance. ECOPACK specifications, grade definitions and product status are available at: www.st.com. ECOPACK is an ST trademark.

Figure 8. Package outline for QFN8 (1.4 x 1.2 x 0.55 mm) - 0.40 mm pitch

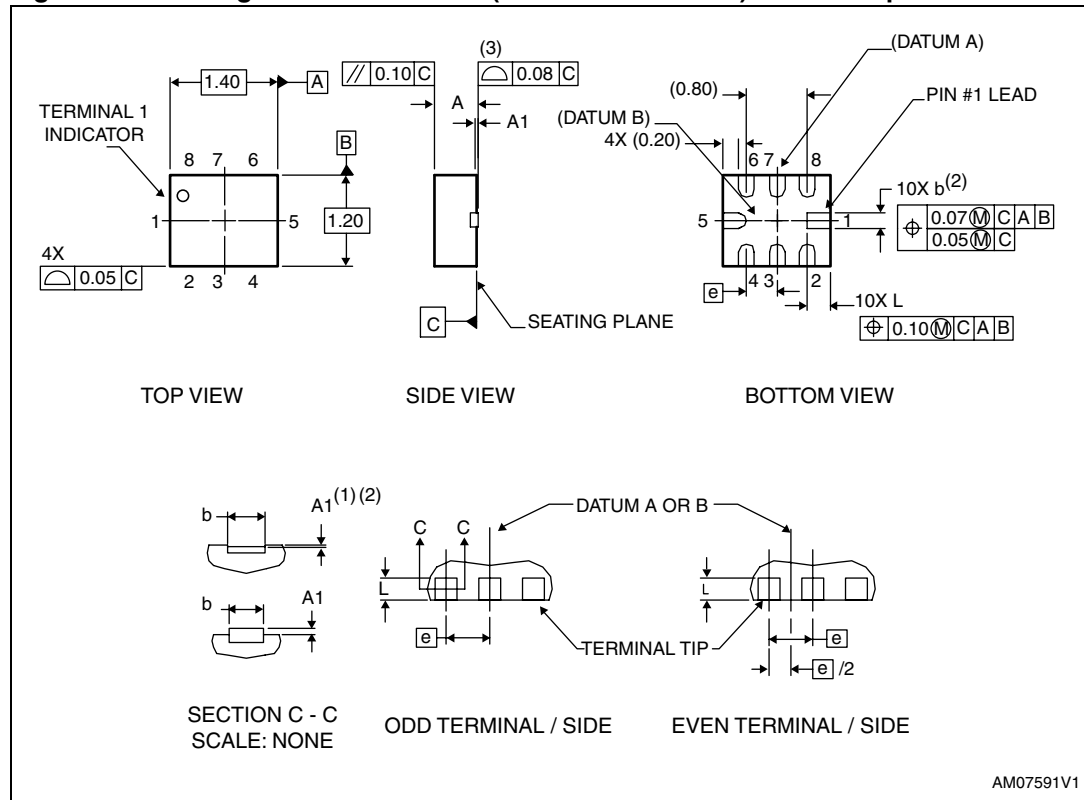

1. Dimension b applies to metallized terminal and is measured between 0.10 and 0.20 mm from the terminal tip. If the terminal has the optional radius on the other end of the terminal. Dimension b should not be measured in that radius area.
2. Applied only for terminals.
3. Bilateral coplanarity zone applies to the exposed heatsink slug as well as the terminals.
4. Dimensions and tolerancing conform to ASME Y14.5M - 1994.

Table 12. Mechanical data for QFN8 (1.4 x 1.2 x 0.55 mm) - 0.40 mm pitch

Symbol	Dimensions			Note
	Millimeters			
	Min.	Nom.	Max.	
A	0.50	0.55	0.60	
A1	0.00	-	0.05	
b	0.15	0.20	0.25	(1)
B	0	-	12°	(2)
e	0.40 BSC			
N	8			(3)
L	0.25	0.30	0.35	

1. Dimension b applies to the metallized terminal and is measured between 0.10 and 0.20 mm from the terminal tip. If the terminal has the optional radius on the other end of the terminal. Dimension b should not be measured in that radius area.
2. All dimensions are in millimeters, B is in degrees.
3. N is the total number of terminals.

Figure 9. Reel for carrier tape - 8 width

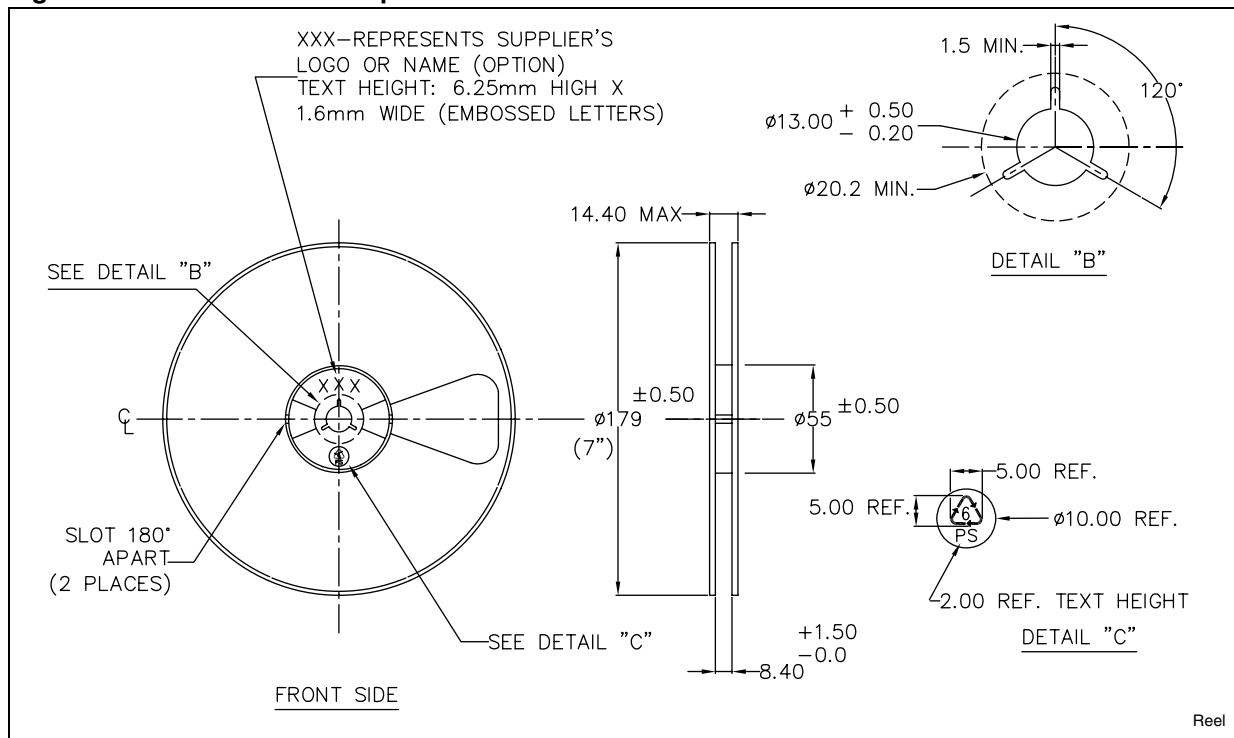

9 Revision history

Table 13. Document revision history

Date	Revision	Changes
14-Jun-2012	1	Initial release.

Please Read Carefully:

Information in this document is provided solely in connection with ST products. STMicroelectronics NV and its subsidiaries ("ST") reserve the right to make changes, corrections, modifications or improvements, to this document, and the products and services described herein at any time, without notice.

All ST products are sold pursuant to ST's terms and conditions of sale.

Purchasers are solely responsible for the choice, selection and use of the ST products and services described herein, and ST assumes no liability whatsoever relating to the choice, selection or use of the ST products and services described herein.

No license, express or implied, by estoppel or otherwise, to any intellectual property rights is granted under this document. If any part of this document refers to any third party products or services it shall not be deemed a license grant by ST for the use of such third party products or services, or any intellectual property contained therein or considered as a warranty covering the use in any manner whatsoever of such third party products or services or any intellectual property contained therein.

UNLESS OTHERWISE SET FORTH IN ST'S TERMS AND CONDITIONS OF SALE ST DISCLAIMS ANY EXPRESS OR IMPLIED WARRANTY WITH RESPECT TO THE USE AND/OR SALE OF ST PRODUCTS INCLUDING WITHOUT LIMITATION IMPLIED WARRANTIES OF MERCHANTABILITY, FITNESS FOR A PARTICULAR PURPOSE (AND THEIR EQUIVALENTS UNDER THE LAWS OF ANY JURISDICTION), OR INFRINGEMENT OF ANY PATENT, COPYRIGHT OR OTHER INTELLECTUAL PROPERTY RIGHT.

UNLESS EXPRESSLY APPROVED IN WRITING BY TWO AUTHORIZED ST REPRESENTATIVES, ST PRODUCTS ARE NOT RECOMMENDED, AUTHORIZED OR WARRANTED FOR USE IN MILITARY, AIR CRAFT, SPACE, LIFE SAVING, OR LIFE SUSTAINING APPLICATIONS, NOR IN PRODUCTS OR SYSTEMS WHERE FAILURE OR MALFUNCTION MAY RESULT IN PERSONAL INJURY, DEATH, OR SEVERE PROPERTY OR ENVIRONMENTAL DAMAGE. ST PRODUCTS WHICH ARE NOT SPECIFIED AS "AUTOMOTIVE GRADE" MAY ONLY BE USED IN AUTOMOTIVE APPLICATIONS AT USER'S OWN RISK.

Resale of ST products with provisions different from the statements and/or technical features set forth in this document shall immediately void any warranty granted by ST for the ST product or service described herein and shall not create or extend in any manner whatsoever, any liability of ST.

ST and the ST logo are trademarks or registered trademarks of ST in various countries.

Information in this document supersedes and replaces all information previously supplied.

The ST logo is a registered trademark of STMicroelectronics. All other names are the property of their respective owners.

© 2012 STMicroelectronics - All rights reserved

STMicroelectronics group of companies

Australia - Belgium - Brazil - Canada - China - Czech Republic - Finland - France - Germany - Hong Kong - India - Israel - Italy - Japan - Malaysia - Malta - Morocco - Philippines - Singapore - Spain - Sweden - Switzerland - United Kingdom - United States of America

www.st.com

