



Main

Range of product	Zelio Relay
Product or component type	Solid state relay
Provided equipment	Thermal pad
Device short name	SSP1
Mounting support	Panel
Network number of phases	1 phase
Contacts type and composition	1 NO
[In] rated current	10 A
Solid state output type	SCR output Zero voltage switching

Complementary

[Uc] control circuit voltage	3...32 V DC
Minimum switching voltage	3 V DC turn-on
Maximum switching voltage	1 V DC turn-off
Response time	0.5 cycle turn-on 0.5 cycle turn-off
Input current limits	10 mA at 12 V DC
Output voltage	24...300 V AC
Load current	0.15...10 A
Absolute maximum voltage	600 V
Surge current	≤ 120 A for 16.6 ms
Maximum I ² t for fusing	60 A ² .s for 8.33 ms at 60 Hz half cycle 66 A ² .s for 10 ms at 50 Hz half cycle
Protection device type	Type 1 - 13 A miniature circuit breaker (MCB) - curve B Type 2 - 10 A miniature circuit breaker (MCB) - curve B
Leakage current	≤ 1 mA off-state
Voltage drop	1.15 V on-state

Disclaimer: This documentation is not intended as a substitute for and is not to be used for determining suitability or reliability of these products for specific user applications

DV/Dt	500 V/ μ s off-state at maximum voltage
Cos phi	0.5 with maximum load
Motor power hp	0.5 hp 120 V AC 1 hp 240 V AC
Insulation resistance	1000 MOhm at 500 V DC
Capacitance unbalance	10 pF for input/output
Dielectric strength	4 kV AC for input/output 4 kV AC for input or output to case
[Uimp] rated impulse withstand voltage	6 kV output to case 6 kV input to output
Tightening torque	1.5...1.7 N.m for input 2...2.2 N.m for output
Connections - terminals	Forked type tag connectors : 9.2 x 4 mm for input Ring lugs : 9.2 x 4 mm for input Forked type tag connectors : 11.7 x 4.5 mm for output Ring lugs : 11.7 x 4.5 mm for output Screw terminals : 0.2...3.3 mm ² , (AWG 24...AWG 12) with cable end for input Screw terminals : 0.5...5.26 mm ² , (AWG 20...AWG 10) with cable end for output Screw terminals : 0.2...3.3 mm ² , (AWG 24...AWG 12) without cable end for input Screw terminals : 0.5...8.26 mm ² , (AWG 20...AWG 8) without cable end for output
Thermal resistance	1.03 °C/W junction to case
Thermal impedance	0.48 °C-in ² /W at 25 psi
Local signalling	LED, green for input
IP degree of protection	IP20
Safety reliability data	B10d = 1731395 MTTFd = 1875.9 years
Product weight	89.2 g

Environment

Ambient air temperature for operation	-40...80 °C
Ambient air temperature for storage	-40...125 °C
Pollution degree	2
Overvoltage category	III
Product certifications	RoHS EAC CE REACH UL CSA
Marking	CSA CE EAC UL
Standards	EN/IEC 60950-1 EN/IEC 62314 CSA C22.2 No 14-13 UL 508

Offer Sustainability

Sustainable offer status	Green Premium product
RoHS (date code: YYWW)	Compliant - since 1522 - Schneider Electric declaration of conformity Schneider Electric declaration of conformity
REACH	Reference not containing SVHC above the threshold Reference not containing SVHC above the threshold
Product environmental profile	Available Product environmental
Product end of life instructions	Available End of life manual

Dimensions

mm
in.

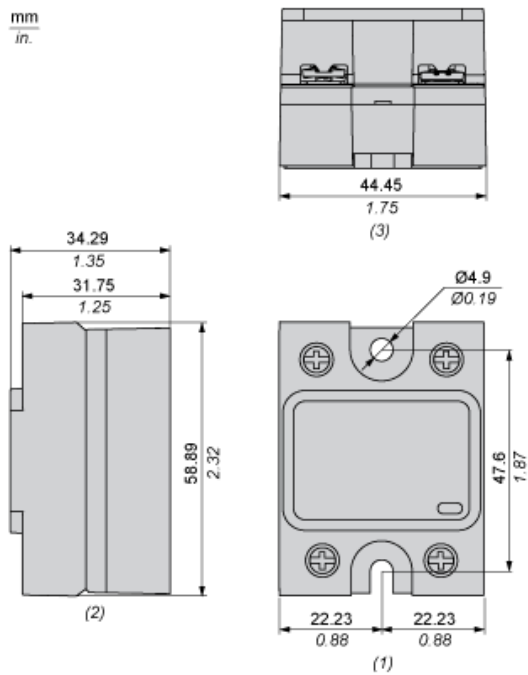

- (1) Front view
- (2) Side view
- (3) Bottom view

Derating Curves

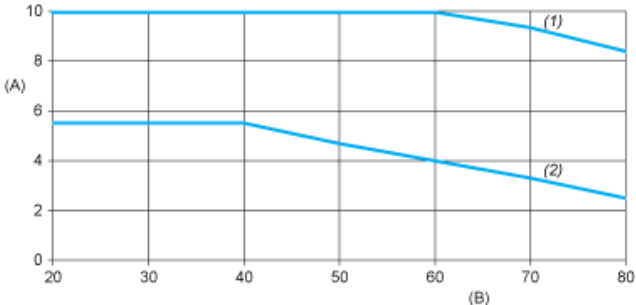

- A : Load Current (Arms)
- B : Ambient Temperature (°C)
- (1) For Heatsink SSRHP25
- (2) No Heatsink