

HONEYWELL

See full Datasheet below...

onlinecomponents.com
THE ONLINE DISTRIBUTOR OF ELECTRONIC COMPONENTS

BUY NOW

 **MASTER**TM
E L E C T R O N I C S

BUY NOW

masterelectronics.com & onlinecomponents.com
are **authorized** e-commerce distributors
of electronic components.



High Sensitivity Bipolar Latching
Digital Hall-Effect Sensor ICs
SS360NT/SS360ST/SS460S

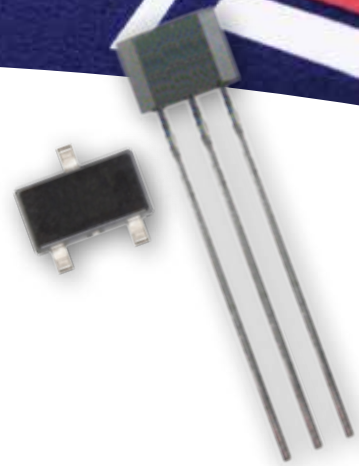

High Sensitivity Bipolar Latching Digital Hall-Effect Sensor ICs

The SS360NT/SS360ST/SS460S High Sensitivity Bipolar Latching Digital Hall-Effect Sensor ICs are small, sensitive and versatile devices that are operated by the magnetic field from a permanent magnet or an electromagnet. They are designed to respond to alternating North and South poles. The SS360NT is turned ON by a North pole while the SS360ST and SS460S are turned ON by a South pole.

The SS360NT/SS360ST/SS460S offer reliable switching points with a high magnetic sensitivity of 30 G typical (55 G maximum). This sensor IC does not use chopper stabilization on the Hall element, providing a clean output signal and a faster latch response time when compared to competitive high sensitivity Hall-effect bipolar latching sensor ICs which do use chopper stabilization.

These products offer reverse polarity protection, deliver a stable output over a -40 °C to 150 °C [-40 °F to 302 °F] temperature range, and can accept any dc supply voltage from 3 Vdc to 24 Vdc.

For brushless dc motor manufacturers who need latching sensors with reliable, consistent performance for more efficient and smaller designs, Honeywell's new family of High Sensitivity Hall-Effect Bipolar Latching Sensor ICs responds to low magnetic fields and offers consistent repeatability while delivering faster response times to a change in magnetic field for better motor efficiency.

These Hall-effect devices are available in two package styles: the SS360NT and SS360ST in the miniature SOT-23 surface mount package and the SS460S in the leaded, flat TO-92-style package.

The SS360NT and SS360ST are available on tape and reel (3000 units per reel). The SS460S is available in a bulk package (1000 units per bag).

What makes our sensors better?

- Fastest response time in its class
- Repeatable magnetics (no jitter)
- Stable magnetics over temperature (-40 °C to 150 °C [-40 °F to 302 °F])
- No additional electronic noise generated by sensor
- Non-chopper-stabilized design

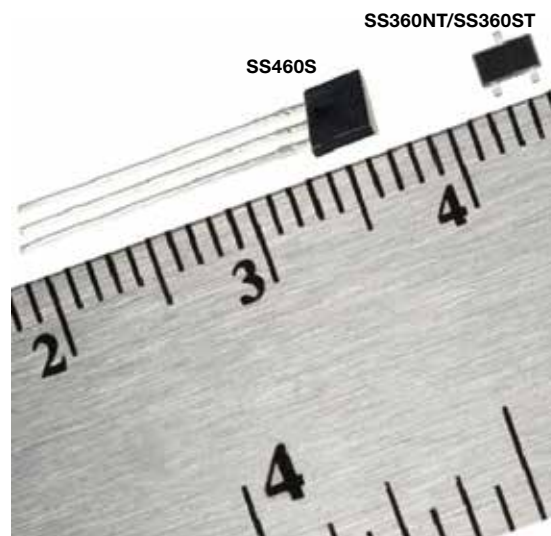

HIGH SENSITIVITY • FAST RESPONSE TIME

Features and Benefits

FASTEST RESPONSE TIME IN ITS CLASS

Provides more efficiency in commutating a brushless dc motor

NO CHOPPER STABILIZATION

Results in a clean output signal

HIGH SENSITIVITY

Operates from only 30 Gauss typical at 25°C [77 °F], and 55 Gauss maximum over the full -40 °C to 150 °C [-40 °F to 302 °F] temperature range, allowing for the use of smaller, magnets or a wider air gap

Reliable switching points without chopper stabilization.

BIPOLAR LATCHING MAGNETICS

Makes these products well-suited for accurate speed sensing and RPM (revolutions per minute) measurement

SUBMINIATURE, SOT-23 SURFACE MOUNT PACKAGE (SS360NT/SS360ST) SUPPLIED ON TAPE AND REEL

Allows for compact design with automated component placement

SMALL, LEADED, FLAT TO-92-STYLE PACKAGE (SS460S)

Allows for a compact PC board layout

WIDE OPERATING VOLTAGE RANGE OF 3 VDC TO 24 VDC

Allows for potential use in a wide range of applications

BUILT-IN REVERSE VOLTAGE

Enhances the protection of the sensor and the circuits

DURABLE DESIGN

Supports operation up to 150 °C [302 °F]

RoHS-compliant material meets Directive 2002/95

Potential Applications

INDUSTRIAL/COMMERCIAL



BRUSHLESS DC MOTOR COMMUTATION

May be used to measure the motor's position, which is communicated to the electronic controller to spin the motor at the correct time and orientation. The sensors determine when the current should be applied to the motor coils to make the magnets rotate at the correct orientation.

SPEED AND RPM SENSING IN ELECTRIC MOTORS AND FANS

May be used with a ring magnet with alternating North and South poles to measure the speed of rotation of a motor or a fan.

TACHOMETER, COUNTER PICKUP

May be used with rotating magnets (one North and one South pole, minimum) as pulse pickup devices to monitor engine/motor speed.



ROBOTICS CONTROL

May be used in very compact brushless DC motors with ring magnets with higher pole density, helping to provide increased RPM/position sensing resolution and better motion control accuracy and efficiency in smaller spaces.

FLOW-RATE SENSING FOR APPLIANCES

May be used mounted outside a sealed chamber containing magnets mounted on a rotating paddle or impeller to measure the liquid flow rate. Each actuation of the sensor by the rotating magnets attached to the paddle, which is turned by the liquid flow, corresponds to a measured quantity of liquid.

TRANSPORTATION

BRUSHLESS DC MOTOR COMMUTATION

ELECTRONIC WINDOW LIFT, ANTI-PINCH POWER WINDOW SYSTEMS

May be used to detect window speed and direction and tell a microcomputer to move the window up or down. A small change in speed indicates an obstacle and signals the control system to adjust the window speed or direction and allow the obstacle to be removed.

VEHICLE CONVERTIBLE ROOF POSITION

May be used to detect the speed and direction of the electric motor that powers convertible roof. With appropriate software, the motor can stop and reverse its course if an obstacle is detected.

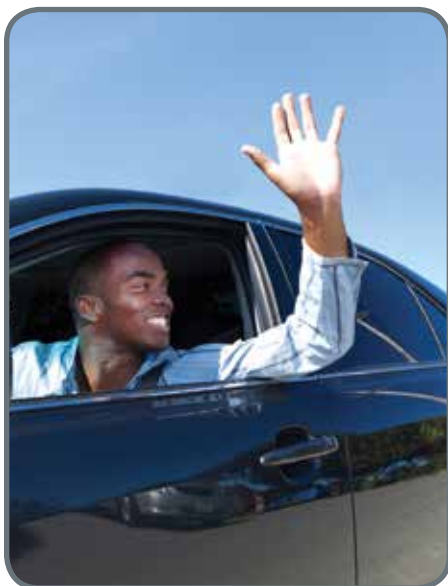

MEDICAL

MEDICAL EQUIPMENT USING ELECTRIC MOTORS

May be used for electronic commutation or motion control.

High Sensitivity Bipolar Latching Digital Hall-Effect Sensor ICs

Table 1. SS360NT/SS360ST/SS460S Performance Specifications (At 3 Vdc to 24 Vdc supply, 20 mA load, TA = -40 °C to 150 °C [-40 °F to 302 °F] except where otherwise specified.)

Characteristic	Condition	Min.	Typ.	Max.	Unit
Supply voltage	-40 °C to 150 °C [-40 °F to 302 °F]	3	—	24	Vdc
Supply current	Vsupply = 3 V at 25 °C [77 °F] —	— —	3.5 —	6 8	mA
Vsat	Gauss >55	—	—	0.6	V
Output leakage current	Gauss >55	—	—	10	μA
Rise/fall time	Vsupply = 12 V at 25 °C [77 °F]	—	—	1.5	μs
Thermal resistance:					
SS460S (flat TO-92-style)	—	—	233	—	°C/W
SS360NT/SS360ST (SOT-23)	—	—	303	—	
Operate	-40 °C to 125 °C [-40 °F to 257 °F]	5	30	55	Gauss
Release	-40 °C to 125 °C [-40 °F to 257 °F]	-55	-30	-5	Gauss
Hysteresis	-40 °C to 125 °C [-40 °F to 257 °F]	40	60	80	Gauss
Operating temperature	Vsupply = 3 Vdc to 24 Vdc	-40 [-40]	—	150 [302]	°C [°F]
Storage temperature	—	-40 [-40]	—	165 [329]	°C [°F]

Table 2. SS360NT/SS360ST/SS460S Magnetic Specifications (At 3 Vdc to 24 Vdc supply, 20 mA load, TA = -40 °C to 125 °C [-40 °F to 257 °F].)

Characteristic	Min.	Typ.	Max.	Unit
Operate	5	30	55	Gauss
Release	-55	-30	-5	Gauss
Differential	40	60	80	Gauss

NOTICE

Bipolar Hall-effect sensor ICs may have an initial output in either the ON or OFF state if powered up with an applied magnetic field in the differential zone (applied magnetic field >Brp and <Bop). Honeywell recommends allowing 10 μs for output voltage to stabilize after supply voltage has reached its final rated value.

NOTICE

The magnetic field strength (Gauss) required to cause the switch to change state (operate and release) will be as specified in the magnetic characteristics. To test the switch against the specified magnetic characteristics, the switch must be placed in a uniform magnetic field.



Table 3. SS360NT/SS360ST/SS460S Absolute Maximum Ratings

Characteristic	Min.	Typ.	Max.	Unit
Supply voltage	-26.0	—	26.0	V
Applied output voltage	-0.5	—	26.0	V
Output current	—	—	20	mA
Magnetic flux	—	—	no limit	Gauss

NOTICE

Absolute maximum ratings are the extreme limits that the device will withstand without damage to the device. However, the electrical and mechanical characteristics are not guaranteed as the maximum limits (above recommended operating conditions) are approached, nor will the device necessarily operate at absolute maximum ratings.

SS360NT/SS360ST/SS460S

Figure 1. Sensor IC Block Diagram

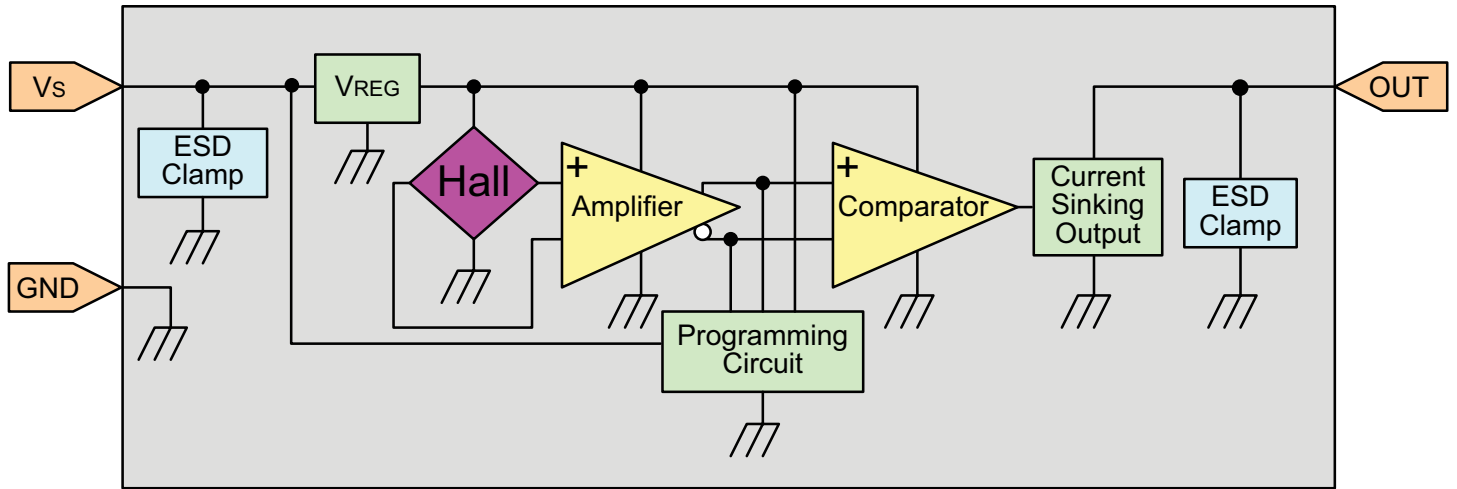

Figure 2. Typical Magnetic Characteristics vs Ambient Temperature at Supply Voltages

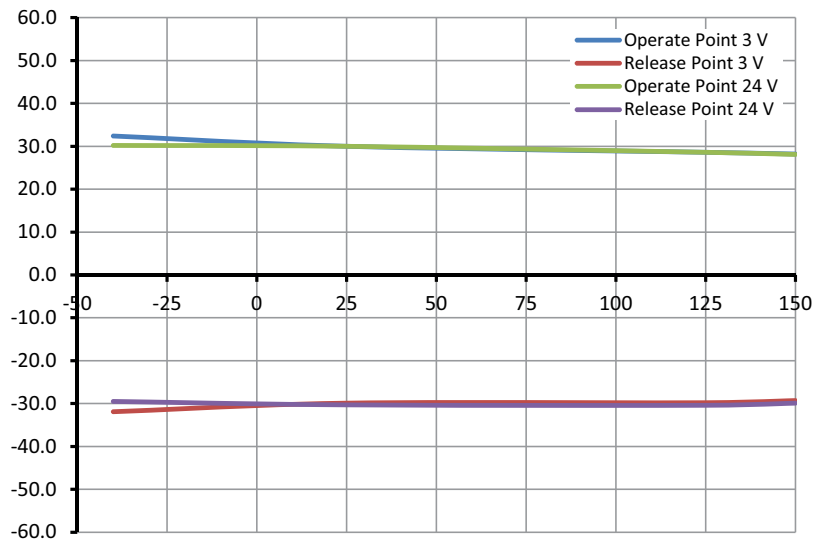
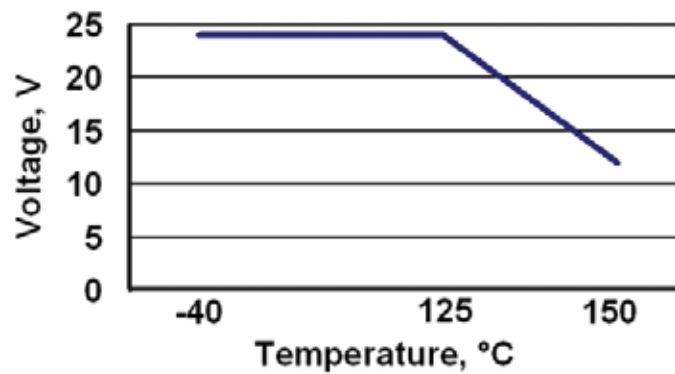

Figure 3. SS360NT and SS360ST Rated Supply Voltage vs Temperature



High Sensitivity Bipolar Latching Digital Hall-Effect Sensor ICs

Figure 4. Magnetic Activation

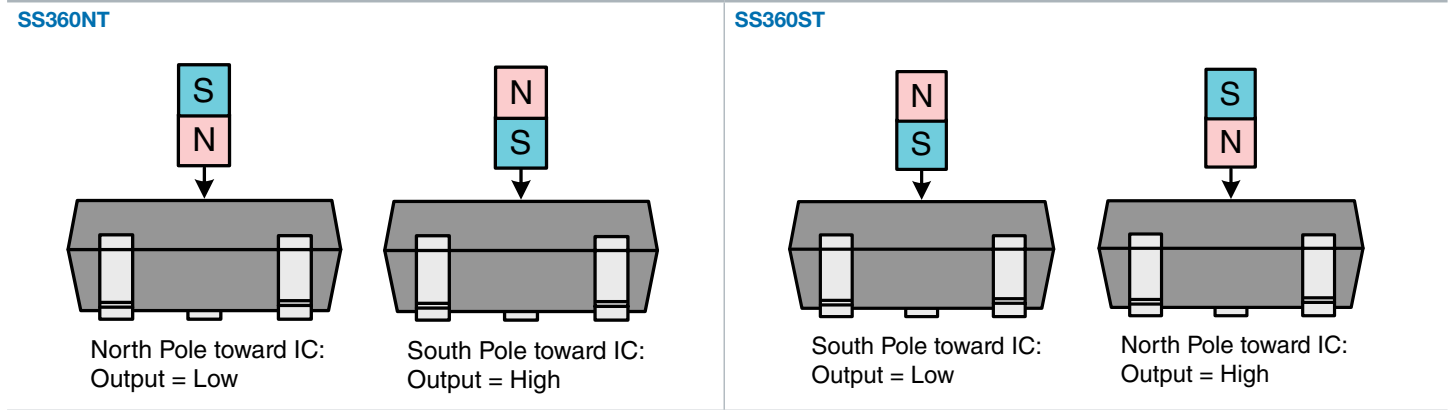
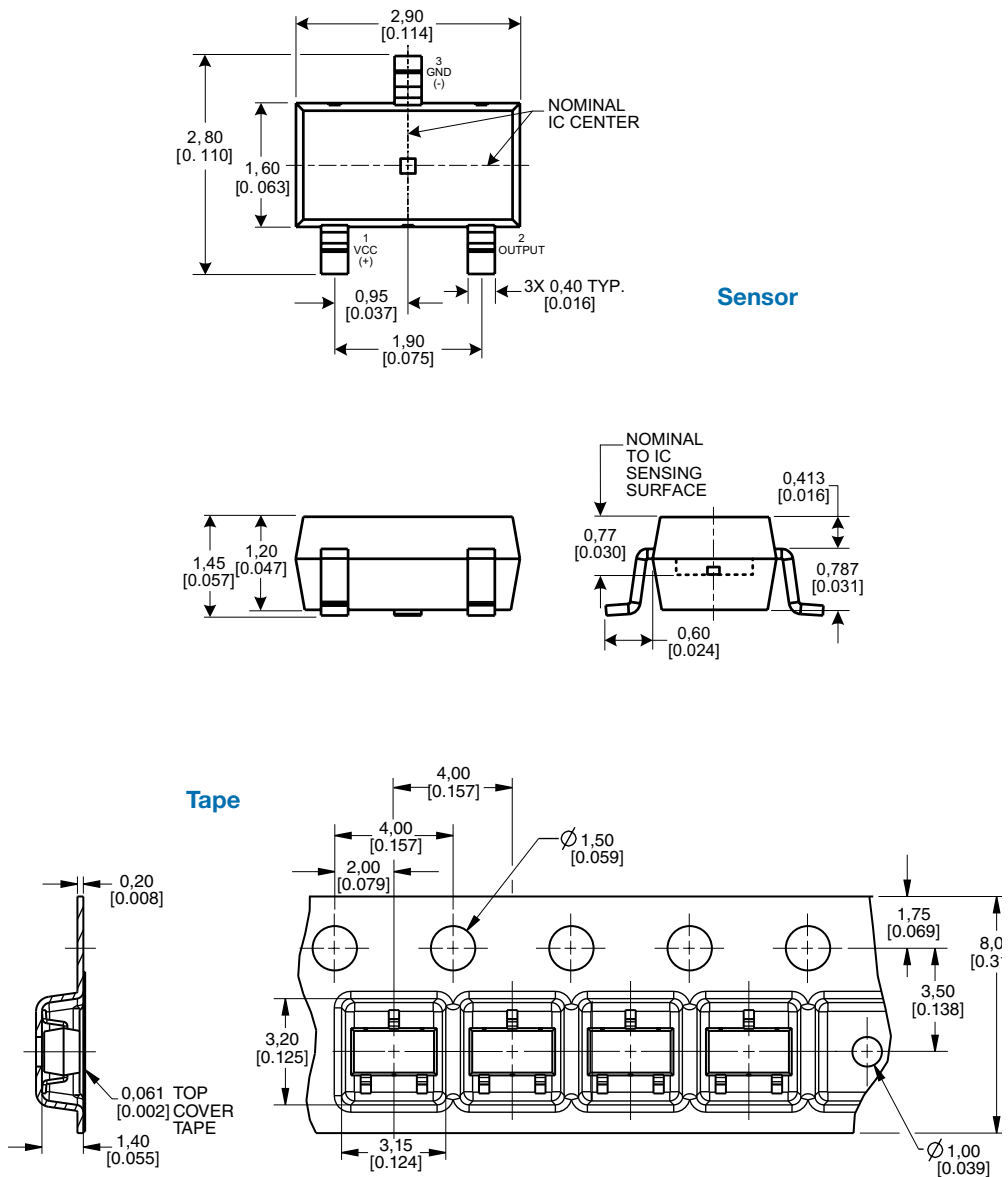

Figure 5. SS360NT/SS360ST Mounting and Tape/Reel Dimensions (For reference only. mm/[in.])



SS360NT/SS360ST/SS460S

Figure 5. SS360NT/SS360ST Mounting and Tape/Reel Dimensions (For reference only. mm/[in.], continued.)

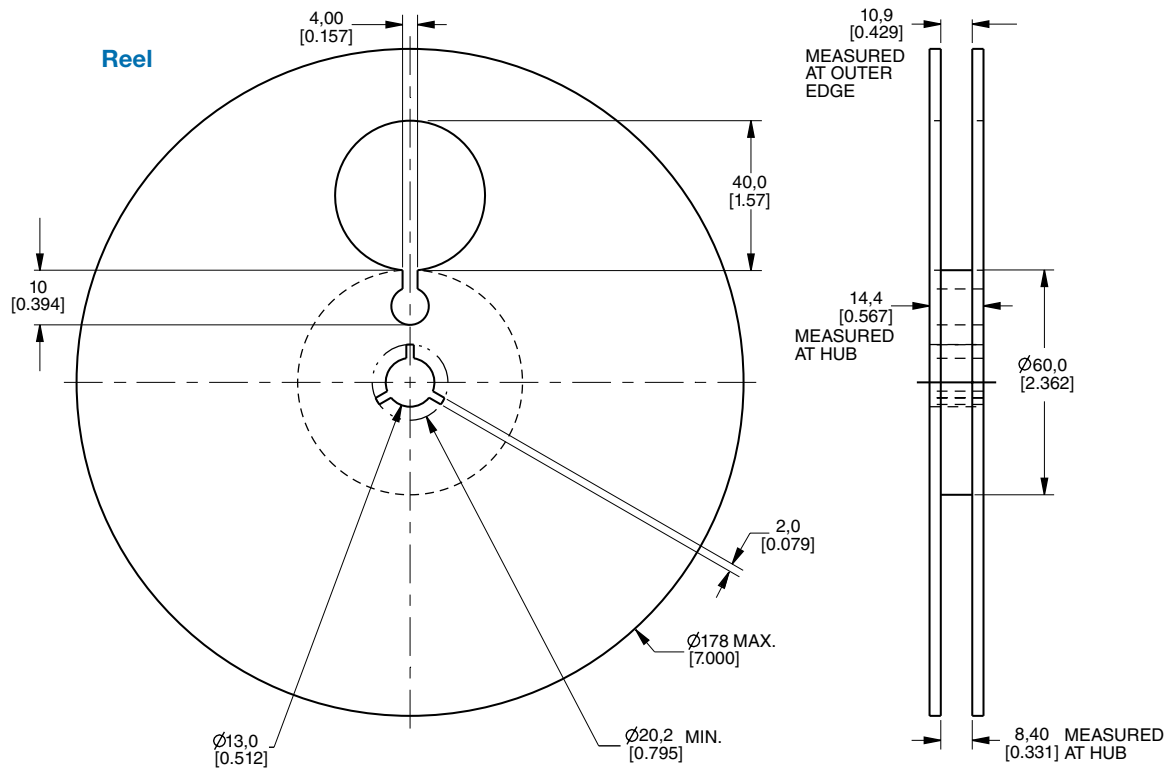
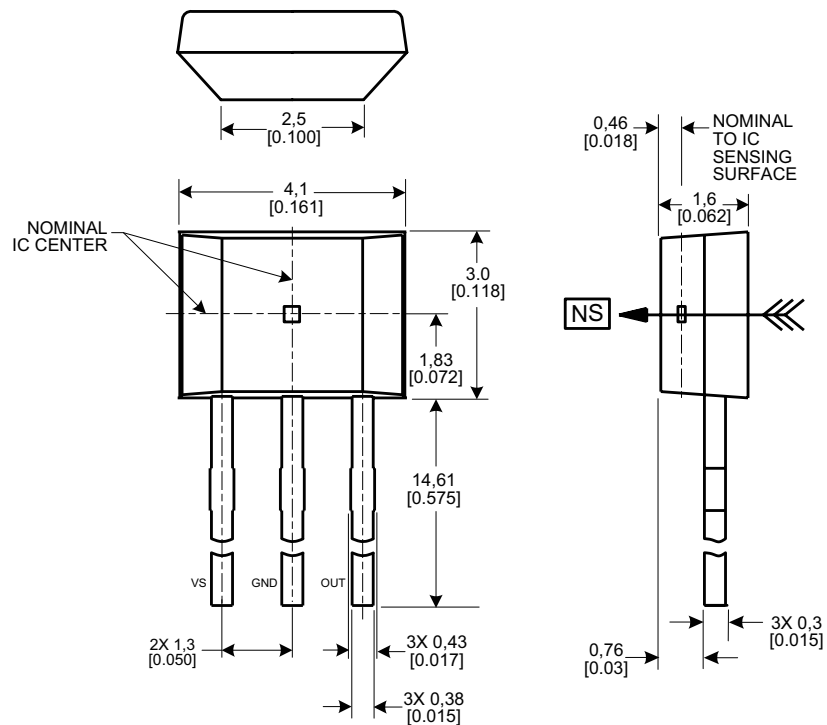

Figure 6. SS460S Mounting Dimensions (For reference only. mm/[in.])



High Sensitivity Bipolar Latching Digital Hall-Effect Sensor ICs

Order Guide

Catalog Listing	Description
SS360NT	High sensitivity bipolar latching, digital Hall-effect sensor IC, North pole activated, SOT-23 package, tape and reel packaging (3000 units per reel)
SS360ST	High sensitivity bipolar latching, digital Hall-effect sensor IC, South pole activated, SOT-23 package, tape and reel packaging (3000 units per reel)
SS460S	High sensitivity bipolar latching, digital Hall-effect sensor IC, South pole activated, flat TO-92-style package, bulk packaging (1000 units per bag)

ADDITIONAL INFORMATION

The following associated literature is available at sensing.honeywell.com:

- Product line guide
- Product range guide
- Product installation instructions
- Application sheets:
 - Magnetic Position Sensing in Brushless DC Electric Motors
- Technical notes:
 - Achieving High Sensitivity and Magnetic Stability without the Use of Chopper Stabilization in Bipolar Latching Hall-Effect Sensors for Brushless DC Motor Applications
 - How to Select Hall-Effect Sensors for Brushless DC Motors

⚠ WARNING **PERSONAL INJURY**

DO NOT USE these products as safety or emergency stop devices or in any other application where failure of the product could result in personal injury.

Failure to comply with these instructions could result in death or serious injury.

⚠ WARNING **MISUSE OF DOCUMENTATION**

- The information presented in this product sheet is for reference only. Do not use this document as a product installation guide.
- Complete installation, operation, and maintenance information is provided in the instructions supplied with each product.

Failure to comply with these instructions could result in death or serious injury.

WARRANTY/REMEDY

Honeywell warrants goods of its manufacture as being free of defective materials and faulty workmanship. Honeywell's standard product warranty applies unless agreed to otherwise by Honeywell in writing; please refer to your order acknowledgement or consult your local sales office for specific warranty details. If warranted goods are returned to Honeywell during the period of coverage, Honeywell will repair or replace, at its option, without charge those items it finds defective. **The foregoing is buyer's sole remedy and is in lieu of all other warranties, expressed or implied, including those of merchantability and fitness for a particular purpose. In no event shall Honeywell be liable for consequential, special, or indirect damages.**

While we provide application assistance personally, through our literature and the Honeywell website, it is up to the customer to determine the suitability of the product in the application.

Specifications may change without notice. The information we supply is believed to be accurate and reliable as of this printing. However, we assume no responsibility for its use.

Sales and Service

Honeywell serves its customers through a worldwide network of sales offices, representatives and distributors. For application assistance, current specifications, pricing or name of the nearest Authorized Distributor, contact your local sales office or email us at **info.sc@honeywell.com**. Visit us on the Web at **sensing.honeywell.com**

Phone and Fax:

Asia Pacific	+65 6355-2828
	+65 6445-3033 Fax
Europe	+44 (0) 1698 481481
	+44 (0) 1698 481676 Fax
Latin America	+1-305-805-8188
	+1-305-883-8257 Fax
USA/Canada	+1-800-537-6945
	+1-815-235-6847
	+1-815-235-6545 Fax

Sensing and Control

Honeywell

1985 Douglas Drive North
Golden Valley, MN 55422
honeywell.com

The Honeywell logo is displayed in a bold, red, sans-serif font.

005947-3-EN
March 2014
© 2014 Honeywell International Inc. All rights reserved.