

Bluetooth® Classic module

Datasheet - preliminary data



- 8 general-purpose I/Os
- User interface
 - AT command Data Package (DP)
 - Firmware upgrade over UART
- ETSI, FCC, IC and Bluetooth qualified
- Single voltage supply: 3.3 V typical
- Micro-sized form factor: 11.6 x 13.5 x 2.9 mm
- Operating temperature range: -40 °C to 85 °C

Features

- Bluetooth radio
 - Fully embedded Bluetooth® v3.0 with SPP and HID profiles
 - Class 2 module
 - Complete RF-ready module
 - Embedded support for MFI iAP2 profile
 - 128-bit encryption security
 - Integrated antenna
- ST Cortex-M4 microprocessor
 - Up to 100 MHz
 - 512 KB Flash
 - 128 KB RAM
- Supports transmission speed with SPP up to 800 Kbits

Contents

1	Description.....	6
2	RoHS compliance.....	7
3	Applications.....	8
4	Software architecture.....	9
	4.1 BT stack layers.....	9
	4.2 Supported profile.....	10
	4.3 AT command set: Data Package.....	10
5	Module block diagram.....	11
6	Hardware specifications	12
	6.1 Recommended operating conditions.....	12
	6.2 Radio features.....	12
	6.3 Absolute maximum ratings.....	12
	6.4 Current consumption.....	12
	6.5 I/O operating characteristics.....	13
	6.6 Pin assignment.....	14
7	Package information	16
	7.1 RF module package information	16
8	Hardware design	18
	8.1 Reflow soldering.....	18
	8.2 UART interface.....	19
	8.3 GPIO interface	20
	8.4 Reset circuit	20
	8.4.1 Simple external reset circuit	21
	8.4.2 Host controlled reset circuit	21
	8.5 External LPO input circuit.....	22
	8.6 MFi co-processor interface.....	22
	8.7 PCB layout guidelines	22
9	Firmware upgrade	23
	9.1 Enter bootloader mode.....	23
	9.2 Transfer the new firmware	23
	9.3 Exit bootloader mode	23
10	Regulatory compliance	24

10.1	FCC certification.....	24
10.1.1	FCC labeling instructions.....	24
10.1.2	Product manual instructions for FCC compliance	25
10.2	IC certification	25
10.2.1	IC labeling instructions	26
10.2.2	Product manual instructions for IC compliance	26
10.3	Bluetooth certification.....	27
10.4	CE certification	27
11	Traceability	28
12	Ordering information.....	29
13	Revision history	30

List of tables

Table 1: Recommended operating conditions	12
Table 2: Radio features.....	12
Table 3: Absolute maximum ratings	12
Table 4: Power consumption	12
Table 5: I/O operating characteristics	13
Table 6: Pin assignment	14
Table 7: Soldering.....	18
Table 8: Traceability information.....	28
Table 9: Ordering information	29
Table 10: Document revision history	30

List of figures

Figure 1: Software architecture overview	9
Figure 2: SPBT3.0DP2 block diagram	11
Figure 3: Pin assignment	14
Figure 4: RF module package outline	16
Figure 5: Recommended land pattern (top view)	17
Figure 6: Soldering profile	19
Figure 7: Connection to host device	19
Figure 8: Typical RS232 circuit	20
Figure 9: Simple external reset circuit	21
Figure 10: Host controlled reset circuit	21

1 Description

The SPBT3.0DP2 is an easy-to-use Bluetooth module that is compliant with Bluetooth v3.0.

The module has among the smallest form factors available in a complete Class 2 RF platform. The SPBT3.0DP2 enables electronic devices with wireless connectivity, requiring no RF experience or expertise to integrate into the final product. As a certified solution, the SPBT3.0DP2 module optimizes time-to-market for end-applications.

The module is designed for maximum performance in a minimal space including high speed UART and 8 general purpose I/O lines, and up to 800 kbps transmission speed with SPP service active and 250 kbps with iAP2 service active.

Its optimized design allows the integration of a complete working Bluetooth modem, including antenna, in the smallest possible size.

Deep Sleep mode reduces power consumption when a Bluetooth connection is not established.

The SPBT3.0DP2 is a surface-mount PCB module that provides fully embedded, ready-to-use Bluetooth wireless technology. The reprogrammable Flash memory contains embedded firmware for serial cable replacement using the Bluetooth SPP profile. Embedded Bluetooth Data Package (DP) firmware provides a user-friendly interface, offering simple control for cable replacement and enabling communication with most Bluetooth-enabled devices that support the SPP profile. The SPBT3.0DP2 supports the iAP2 profile, allowing communication with the newest Apple® iOS Bluetooth-enabled devices.

An Apple authentication IC is required to exchange data with an Apple device or access an Apple device application. The DP FW includes a Bluetooth iAP2 profile capable of recognizing the Apple authentication chip.

Customers using the Apple authentication IC must register as developers to become an Apple certified MFI member. License fees may apply. For additional information, please visit the Apple developer website.

Certified MFI developers developing electronic accessories that connect to the iPod®, iPhone® and iPad®, gain access to technical documentation, hardware components, technical support and certification logos.

Customized firmware for peripheral device interaction, power optimization, security, and other proprietary features may be supported and can be ordered pre-loaded and configured.

2 RoHS compliance

ST Bluetooth modules comply with the ECOPACK2 level of RoHS compliance.

3 Applications

The SPBT3.0DP2 is suitable for a wide range of applications, such as:

- Serial cable replacement
- M2M industrial control
- Service diagnostics
- Data acquisition equipment
- Machine control
- Sensor monitoring
- Security systems
- Mobile health

4 Software architecture

Figure 1: Software architecture overview

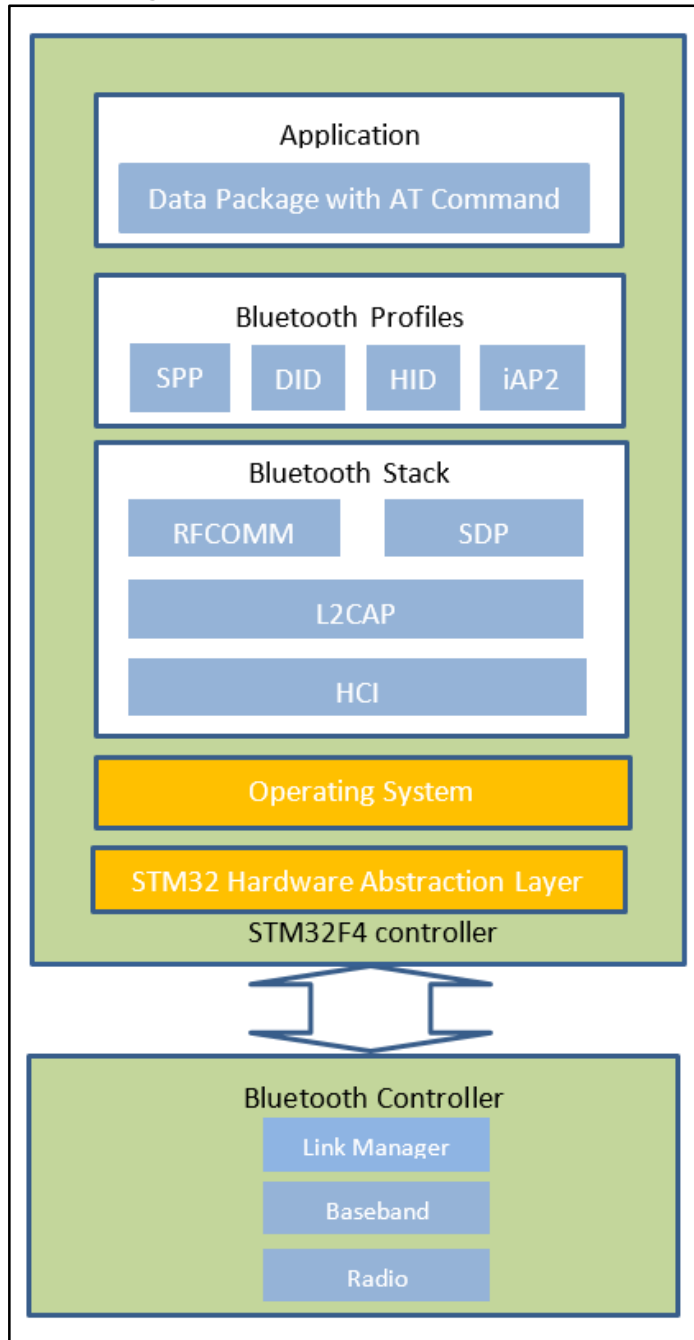

4.1 BT stack layers

- Bluetooth v3.0
- Device power modes: active, deep sleep
- Connection modes: active, sniff
- Wake on Bluetooth feature optimizes power consumption of host CPU

- Authentication and encryption
- Encryption key length from 8 bits to 128 bits
- Secure simple pairing support
- Persistent Flash memory for BD address and user parameter storage
- All ACL (asynchronous connection-less) packet types
- Master/slave switch supported during connection and post connection
- Dedicated inquiry access code for improved inquiry scan performance
- Dynamic packet selection channel quality-driven data rate to optimize link performance
- Dynamic power control
- Bluetooth radio natively supports 802.11b co-existence AFH
- RFCOMM, SDP, and L2CAP protocols supported

4.2 Supported profile

- Serial port profile (SPP)
- Human interface device (HID)
- iPhone accessory profile 2 (iAP2)
- Device identification profile (DID)

4.3 AT command set: Data Package

The complete command list is available in user manual UM2077 SPBT3.0DPx data package, which you can download from www.st.com.

5 Module block diagram

Figure 2: SPBT3.0DP2 block diagram

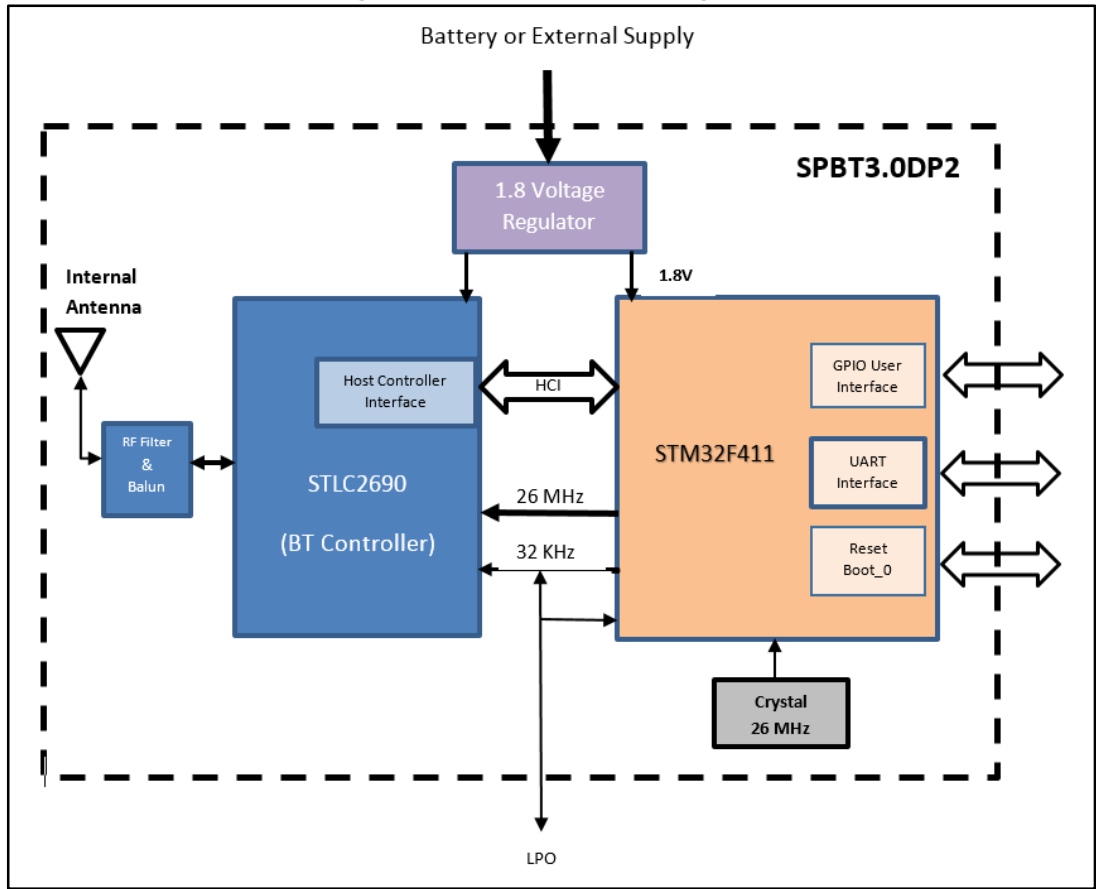

6 Hardware specifications

General conditions ($V_{IN} = 3.3\text{ V}$ and 25 °C).

6.1 Recommended operating conditions

Table 1: Recommended operating conditions

Rating	Min.	Typical	Max.	Unit
Operating temperature range	- 40	-	+8 5	°C
Supply voltage V_{IN}	2.1	3.3	3.6	V
Signal pin voltage	-	1.8	-	V

6.2 Radio features

Table 2: Radio features

Feature	Min.	Typical	Max.	Unit
Bluetooth version	-	3.0	-	
Bluetooth class	-	2	-	
Radiated transmit power	-	-	+2.6	dBm
Receiver sensitivity	-	-88	-	dBm
RF frequency	2402	-	2480	MHz

6.3 Absolute maximum ratings

Table 3: Absolute maximum ratings

Rating	Min.	Typical	Max.	Unit
Storage temperature range	-40	-	+85	°C
Supply voltage, V_{IN}	-0.3	-	+5.5	V
I/O pin voltage, V_{IO}	-0.3	+1.8	+2.1	V

6.4 Current consumption

Test conditions:

- Configuration variable: default
- Temperature: 25 °C

Table 4: Power consumption

Modes (typical power consumption)	Typical	Unit
No connection, Page/Inquiry Scan, Deep Sleep Mode, External LPO	1.2	mA
No connection, Page/Inquiry Scan, Deep Sleep Mode, Internal LPO	5	mA
No connection, Page/Inquiry Scan, Active Mode	9	mA

Modes (typical power consumption)	Typical	Unit
Connection, no data traffic, Active Mode	12	mA
Connection, no data traffic, Sniff Mode	9.5	mA
Connection, 450 Kbps tx rx data , Active mode	26 ⁽¹⁾	mA

Notes:

⁽¹⁾Peak current during transmission: 80 mA.

6.5 I/O operating characteristics

Table 5: I/O operating characteristics

Symbol	Parameter	Min.	Max.	Unit	Conditions
V _{IL}	Low-level input voltage	-	0.5	V	V _{IN} , 3.3 V
V _{IH}	High-level input voltage	1.3	-	V	V _{IN} , 3.3 V
V _{OL}	Low-level output voltage	-	0.5	V	V _{IN} , 3.3 V
V _{OH}	High-level output voltage	1.4	-	V	V _{IN} , 3.3 V
I _{OL}	Low-level output current	-	4	mA	V _{OL} = 0.4 V
I _{OH}	High-level output current	-	4	mA	V _{OH} = 1.8 V
R _{PU}	Pull-up resistor	30	50	kΩ	Resistor turned on ⁽¹⁾
R _{PD}	Pull-down resistor	30	50	kΩ	Resistor turned on ⁽¹⁾

Notes:

⁽¹⁾Normally not used. Firmware dependent.

6.6 Pin assignment

Figure 3: Pin assignment

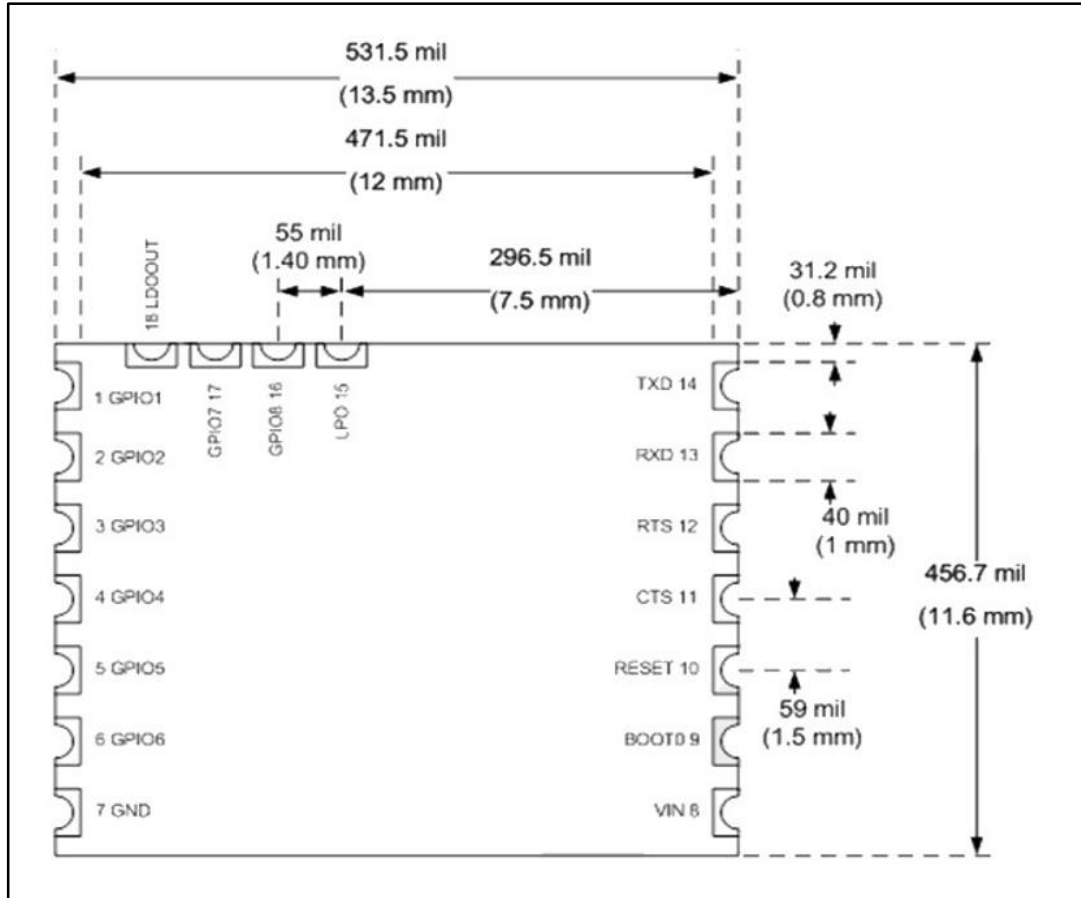

Table 6: Pin assignment

Pin	Name	Description	I/O	Note
1	GPIO1	GPIO indicating BT connection status - 1: BT connection is active - 0: BT connection is not active	O	5 V tolerant
2	GPIO2	General purpose I/O	I/O	
3	GPIO3	General purpose I/O	I/O	5 V tolerant
4	GPIO4	GPIO indicating module power status - 1: active mode - 0: Deep Sleep Mode	O	
5	GPIO5	I2C_SDA line for MFI chip or general purpose I/O	I/O	
6	GPIO6	I2C_SCL line for MFI chip or general purpose I/O	I/O	5 V tolerant
7	GND	Reference ground	NA	
8	Vin	Main power supply input	NA	
9	Boot 0	Boot 0 pin	I	

Pin	Name	Description	I/O	Note
10	RESETn	Reset input (active low for 5 ms)	I	
11	CTS	Request to send (active low)	I	5 V tolerant
12	RTS	Clear to send (active low)	O	5 V tolerant
13	RXD	Receive data	I	5 V tolerant
14	TXD	Transmit data	O	5 V tolerant
15	LPO	Low power 32 KHz oscillator	I/O	See Section 8.5: "External LPO input circuit"
16	GPIO7	General purpose I/O	I/O	5 V tolerant
17	GPIO8	General purpose I/O	I/O	5 V tolerant
18	+1.8V OUT	+1.8 V out (max 10 mA)	NA	

8 Hardware design

The SPBT3.0DP2 module with Data Package embedded firmware supports UART, I²C and GPIO hardware interfaces.

Note:

- All unused pins should be left floating; do not ground.
- All GND pins must be well grounded.
- The area around the module should be free of any ground planes, power planes, trace routings, or metal for 6 mm from the module antenna position, in all directions.
- Traces should not be routed under the module.

8.1 Reflow soldering

The SPBT3.0DP2 is a high temperature-strength surface-mount Bluetooth module supplied on a PCB with the following characteristics: 18-pin, 6-layer . The recommended final assembly reflow profiles are indicated below.

The soldering phase must be executed with care. To prevent undesired melting, particular attention must be paid to the setup of the peak temperature.

The following soldering indications are based on temperature profile recommendations.

Table 7: Soldering

Profile feature	PB-free assembly
Average ramp-up rate ($T_{S_{MAX}}$ to T_P)	3 °C/sec max
Preheat: – Temperature min. (T_S min.) – Temperature max. (T_S max.) – Time (t_s min. to t_s max.)(t_s)	150 °C 200 °C 60-100 sec
Time maintained above: – Temperature T_L – Temperature T_L	217 °C 60-70 sec
Peak temperature (T_P)	240 + 0 °C
Time within 5 °C of actual peak temperature (T_P)	10-20 sec
Ramp-down rate	6 °C/sec
Time from 25 °C to peak temperature	8 minutes max.

Figure 6: Soldering profile

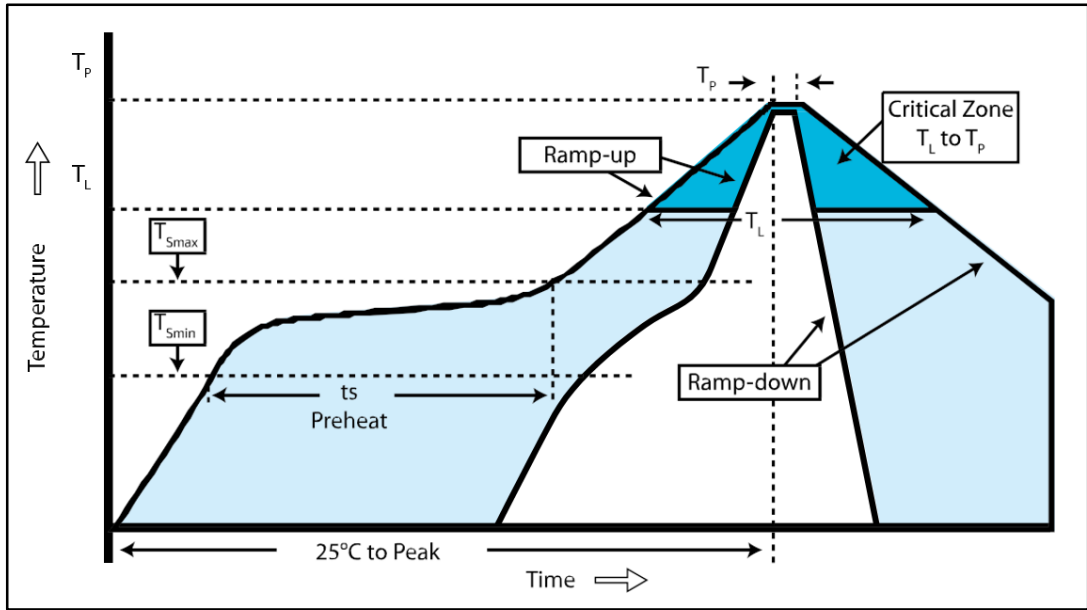

8.2 UART interface

The UART is compatible with the 16550 industry standard. Four signals are provided with the UART interface. The TXD and RXD pins are used for data, while the CTS and RTS pins are used for flow control.

Figure 7: Connection to host device

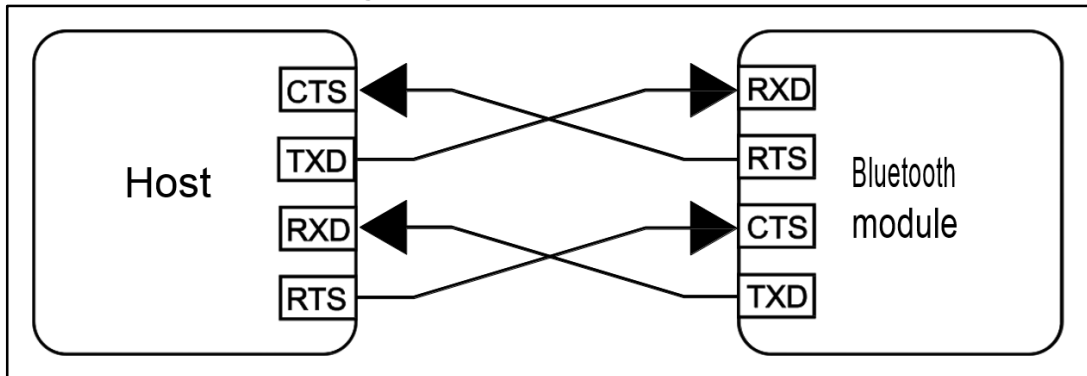
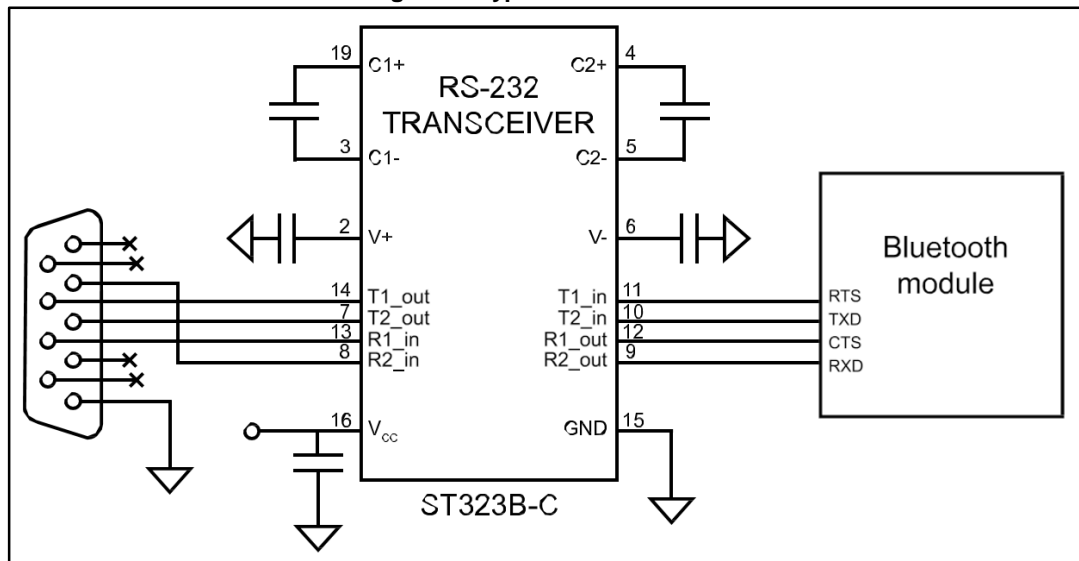

Figure 8: Typical RS232 circuit



8.3 GPIO interface

Module GPIO configuration depends on the Data Package embedded firmware.

By default the GPIO1, GPIO4, GPIO5 and GPIO6 have specific functions. The remaining GPIOs are available to the HOST processor that can configure them using AT commands.

GPIO1: Bluetooth Connection Status

- 0: BT connection not present
- 1: BT connection is present

GPIO4: Module Power Status

- 1: module is in Active Mode
- Blinking: module is in Deep Sleep Mode

GPIO6: I²C SCL pin to be connected to MFi co-processor. External pull-up resistor is needed.

GPIO5: I²C SDA pin to be connected to MFi co-processor. External pull-up resistor is needed.

GPIOs without a specific functionality can be handled by the HOST processor using the following commands:

- AT+AB GPIOConfig [GPIO pin] [I/O]
- AT+AB GPIORead [GPIO pin]
- AT+AB GPIOWrite [GPIO pin] [1/0]

For more details refer to the AT Command Data Package user manual.

All GPIOs are capable of sinking and sourcing 4 mA of I/O current.

8.4 Reset circuit

Two types of system reset circuits are detailed below.

The maximum voltage that can be supplied to the RESET pin is 3.6 V. As shown in [Figure 9: "Simple external reset circuit"](#) and [Figure 10: "Host controlled reset circuit"](#) the RESET is

active low, in the absence of a reset circuit the pin is internally pulled up and therefore inactive.

8.4.1 Simple external reset circuit

The figure below shows a simple push-button reset circuit.

Figure 9: Simple external reset circuit

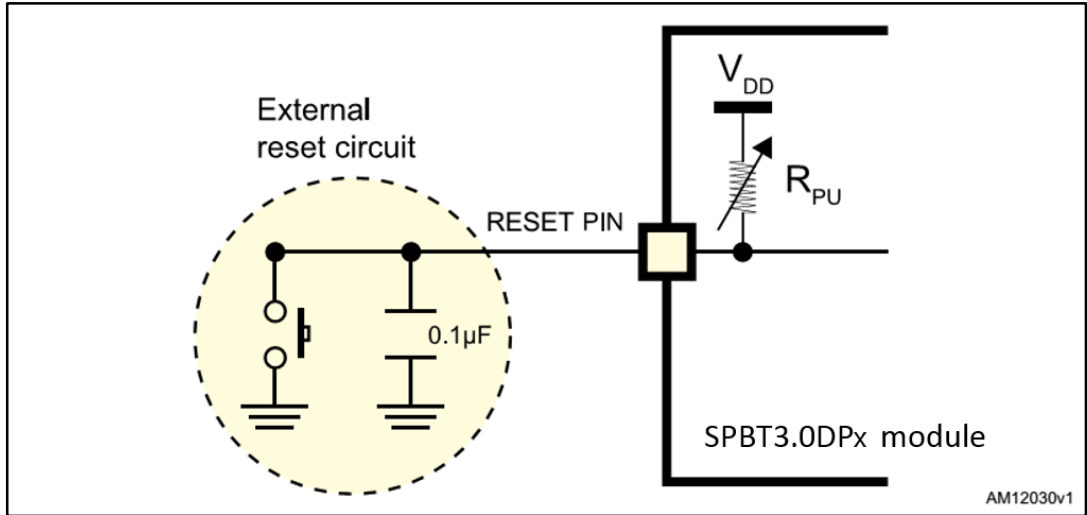

Note: RPU ranges from 30 kΩ to 50 kΩ internally provided.

8.4.2 Host controlled reset circuit

The figure below shows a typical host controlled reset circuit.

Figure 10: Host controlled reset circuit

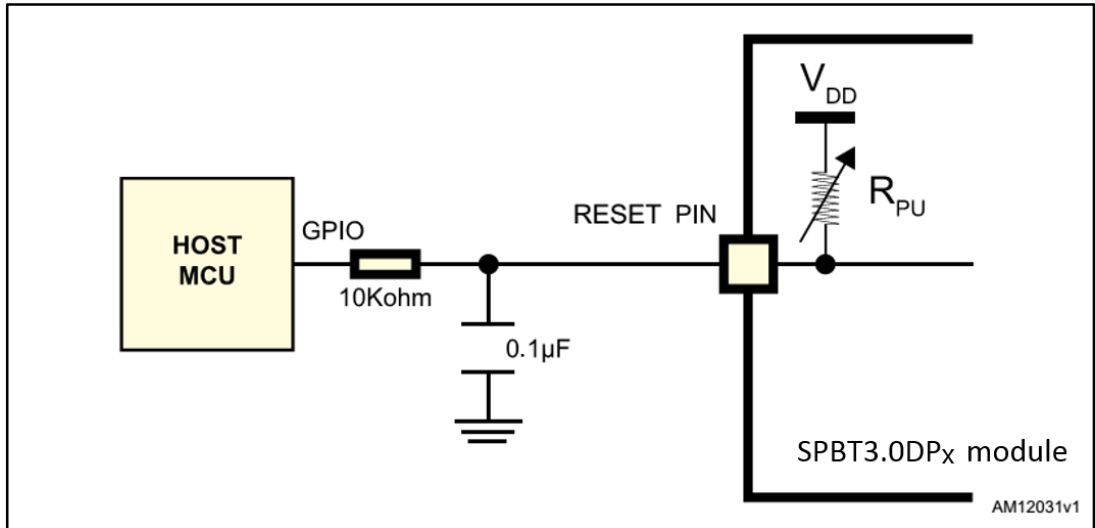

Note:

- RPU ranges from 30 kΩ 50 kΩ internally.
- The host reset resistor should be from 1 kΩ to 10 kΩ

8.5 External LPO input circuit

An optional external LPO may be connected to the PIN 15 of the module to allow lower power consumption in Deep sleep and Sniff modes.

LPO parameters:

- Frequency: 32.768 KHz
- Tolerance: +/- 150 ppm typical, +/- 250 maximum
- Absolute maximum supplied voltage at LPO pin: +1.8 V
- VIL min/max = 0 V/+0.5 V
- VIH min/max = +1.47 V/+1.8 V
- Input capacitance: 2.5 pF maximum

By default the 32 KHz is internally generated and is output on the LPO pin of the module. In order to enable the use of external low power oscillator, the UseExtLPO variable has to be set to TRUE (refer to the Data Package user manual for details).

8.6 MFi co-processor interface

A specific MFi co-processor is needed to enable iAP2 profile for connection with Apple devices. The MFi co-processor component details are available for licensed MFi developers from the MFi program.

The MFi co-processor can be connected to the module through the I2C pins. External pull-up resistors are needed on both lines.

The Data Package firmware handles the communication with the MFi co-processor.

8.7 PCB layout guidelines

The SPBT3.0DP2 module require proper placement on PCB to ensure optimal performance. The antenna on the PCB has an omnidirectional radiation pattern. To maximize antenna efficiency, an adequate grounding plane must be provided under the module, respecting the distance for the antenna clearance.

The position of the module on the host board and overall design of the product enclosure contributes to the antenna performance. Poor design can limit the antenna radiation patterns and can result in reflection, diffraction, and/or scattering of the transmitted signal thus limiting the useful operating range.

Basic guidelines:

- Never place the ground plane or route copper traces directly underneath the antenna portion of the module
- Keep a 6 mm clear zone surrounding the antenna (no ground planes, no traces)
- Never place the antenna close to metallic objects
- Keep wiring, components and objects away from antenna
- Do not place the antenna in a metallic or metalized plastic enclosure
- Enclosure walls should be 20 mm or more away from the antenna in all directions
- If possible, mount antenna overhanging the edge of the host board

9 Firmware upgrade

Bluetooth is a consolidated and well known standard, anyhow interoperability issues may arise whenever a new version of an operating system (Android, Windows, Linux, iOS, etc.) appear on the market. Bug fixes and new features may also become available.

The SPBT3.0DP2 Data Package firmware has been designed to be upgradable via UART interface.

It is recommended to support the firmware update procedure in order to always get the benefit of latest firmware versions.

ST may update the FW provided with the modules at any time. ST recommends that users regularly check for documentation.

The SPBT3.0DP2 module leverages the STM32 built-in bootloader to load the new firmware. It is a three-step procedure:

1. Enter bootloader mode
2. Transfer the new firmware
3. Exit bootloader mode

9.1 Enter bootloader mode

To enter the Bootloader mode:

1. Set the BOOT pin to HIGH level
2. Reset the module:
 - a. Set the RESET pin to HIGH
 - b. Pause
 - c. Set the RESET pin to LOW

9.2 Transfer the new firmware

The specification of the protocol used in the STM32 bootloader to download the new firmware is described in the document:

http://www.st.com/web/en/resource/technical/document/application_note/CD00264342.pdf

A reference implementation of the STM32 bootloader protocol can be found at the following link:

<http://sourceforge.net/projects/stm32flash/>

The STM32 Flash loader demonstrator, a Windows GUI that implement that protocol can be downloaded at the following link:

<http://www.st.com/web/en/catalog/tools/PF257525>

9.3 Exit bootloader mode

To exit Bootloader mode:

1. Set the BOOT pin to LOW
2. Reset the module:
 - a. Set the RESET pin to HIGH
 - b. Pause
 - c. Set the RESET pin to LOW

10 Regulatory compliance

10.1 FCC certification

This module has been tested and found to comply with FCC part 15 rules. These limits are designed to provide reasonable protection against harmful interference in approved installations. This equipment generates, uses, and can radiate radio frequency energy and, if not installed and used in accordance with the instructions, may cause harmful interference to radio communications.

However, there is no guarantee that interference may not occur in any particular installation.

Operation is subject to the following two conditions:

1. This device may not cause harmful interference
2. this device must accept any interference received, including interference that may cause undesired operation. Modifications or changes to this equipment not expressly approved by STMicroelectronics may render void the user's authority to operate this equipment.

The safe user distance for RF exposure is ≥ 5 mm (in compliance with 447498 D01 General RF Exposure Guidance v06).

Modular approval

FCC ID: S9NSPBT30DP2

In accordance with FCC part 15, the SPBT3.0DP2 is listed as a modular transmitter device.

This module is evaluated for stand-alone use only. Finished products incorporating multiple transmitters must comply with collocation and RF exposure requirements in accordance with FCC multi-transmitter product procedures. Collocated transmitters operating in portable RF exposure conditions (e.g. <20 cm from persons including but not limited to body-worn and handheld devices) may require separate approval.

10.1.1 FCC labeling instructions

When integrating the SPBT3.0DP2 into the final product, the OEM must ensure that the FCC labeling requirements are satisfied. A statement must be included on the exterior of the final product which indicates that the product includes a certified module. The label should state the following (or similar wording that conveys the same meaning):

Contains FCC ID: S9NSPBT30DP2

OR

This product contains FCC ID: S9NSPBT30DP2

The OEM must include the following statements on the exterior of the final product unless the product is too small (e.g. less than 4 x 4 inches) This device complies with Part 15 of the FCC Rules. Operation is subject to the following two conditions:

1. this device may not cause harmful interference
2. this device must accept any interference received, including any interference that may cause undesired operation.

10.1.2 Product manual instructions for FCC compliance

This section applies to OEM final products containing the SPBT3.0DP2 module, subject to FCC compliance. The final product manual must contain the following statement (or a similar statement that conveys the same meaning):

Warning: Changes or modifications not expressly approved by the party responsible for compliance could void the user's authority to operate the equipment. (Part. 15.21)

In the case where an OEM seeks Class B (residential) limits for the final product, the following statement must be included in the final product manual:

Note: This equipment has been tested and found to comply with the limits for a Class B digital device, pursuant to part 15 of the FCC Rules. These limits are designed to provide reasonable protection against harmful interference in a residential installation. This equipment generates, uses and can radiate radio frequency energy and, if not installed and used in accordance with the instructions, may cause harmful interference to radio communications. However, there is no guarantee that interference will not occur in a particular installation. If this equipment does cause harmful interference to radio or television reception, which can be determined by turning the equipment off and on, the user is encouraged to try to correct the interference by one or more of the following measures:

- *Reorient or relocate the receiving antenna.*
- *Increase the separation between the equipment and receiver.*
- *Connect the equipment into an outlet on a circuit different from that to which the receiver is connected.*
- *Consult the dealer or an experienced radio/TV technician for help.*

In cases where an OEM seeks the lesser category of a Class A digital device for the final product, the following statement must be included in the final product manual:

Note: This equipment has been tested and found to comply with the limits for a Class A digital device, pursuant to part 15 of the FCC Rules. These limits are designed to provide reasonable protection against harmful interference when the equipment is operated in a commercial environment. This equipment generates, uses, and can radiate radio frequency energy and, if not installed and used in accordance with the instruction manual, may cause harmful interference to radio communications. Operation of this equipment in a residential area is likely to cause harmful interference in which case the user will be required to correct the interference at his expense.

10.2 IC certification

The SPBT3.0DP2 module has been tested and found compliant with the IC RSS-210 rules. These limits are designed to provide reasonable protection against harmful interference in approved installations. This equipment generates, uses, and can radiate radio frequency energy and, if not installed and used in accordance with the instructions, may cause harmful interference to radio communications.

However, there is no guarantee that interference may not occur in any particular installation.

This device complies with RSS-210 of the IC rules. Operation is subject to the following two conditions:

1. this device may not cause harmful interference
2. this device must accept any interference received, including interference that may cause undesired operation.

Modifications or changes to this equipment not expressly approved by STMicroelectronics may render void the user's authority to operate this equipment.

The safe user distance for RF exposure is ≥ 15 mm (in compliance with RSS-102 Issue 5).

Modular approval

IC: 8976C-SPBT302

In accordance with IC RSS-210, the SPBT3.0DP2 is listed as a modular transmitter device.

This module is evaluated for stand-alone use only. Finished products incorporating multiple transmitters must comply with collocation and RF exposure requirements in accordance with IC multi-transmitter product procedures. Collocated transmitters operating in portable RF exposure conditions (e.g. <20 cm from persons including but not limited to body-worn and handheld devices) may require separate approval.

10.2.1 IC labeling instructions

When integrating the SPBT3.0DP2 into the final product, the OEM must ensure that the IC labeling requirements are satisfied. A statement must be included on the exterior of the final product which indicates that the product includes a certified module. The label should state the following (or similar wording that conveys the same meaning):

Contains IC: 8976C-SPBT302

OR

This product contains IC: : 8976C-SPBT302

The OEM must include the following statements on the exterior of the final product unless the product is too small (e.g. less than 4 x 4 inches):

This device complies with RSS-210 of the IC Rules. Operation is subject to the following two conditions:

1. this device may not cause harmful interference
2. this device must accept any interference received, including any interference that may cause undesired operation.

10.2.2 Product manual instructions for IC compliance

This section applies to OEM final products containing the SPBT3.0DP2 module, subject to IC compliance. The final product manual must contain the following statement (or a similar statement that conveys the same meaning):

Warning: Changes or modifications not expressly approved by the party responsible for compliance could void the user's authority to operate the equipment. (RSS-210)

In cases where an OEM seeks Class B (residential) limits for the final product, the following statement must be included in the final product manual:

Note: This equipment has been tested and found to comply with the limits for a Class B digital device, pursuant to RSS-210 of the IC Rules. These limits are designed to provide reasonable protection against harmful interference in a residential installation. This equipment generates, uses and can radiate radio frequency energy and, if not installed and used in accordance with the instructions, may cause harmful interference to radio communications. However, there is no guarantee that interference will not occur in a particular installation. If this equipment does cause harmful interference to radio or television reception, which can be determined by turning the equipment off and on, the user is encouraged to try to correct the interference by one or more of the following measures:

- Reorient or relocate the receiving antenna.
- Increase the separation between the equipment and receiver.

- Connect the equipment into an outlet on a circuit different from that to which the receiver is connected.
- Consult the dealer or an experienced radio/TV technician for help.

In cases where an OEM seeks the lesser category of a Class A digital device for the final product, the following statement must be included in the final product manual:

Note: This equipment has been tested and found to comply with the limits for a Class A digital device, pursuant to RSS-210 of the IC Rules. These limits are designed to provide reasonable protection against harmful interference when the equipment is operated in a commercial environment. This equipment generates, uses, and can radiate radio frequency energy and, if not installed and used in accordance with the instruction manual, may cause harmful interference to radio communications. Operation of this equipment in a residential area is likely to cause harmful interference in which case the user will be required to correct the interference at his expense.

10.3 Bluetooth certification

Module with embedded stack and profile has been qualified according to SIG qualification rules:

- Bluetooth SIG Declaration ID: D031101 (subset QDID 84049)
- Qualified Design ID (QDID): 81857
- Product type: End Product
- Core spec version: 3.0
- Product descriptions: Bluetooth module, spec V3.0

10.4 CE certification

The module has been certified according to the following certification rules:

- CE Expert opinion: 0586-ARSQ00068
- Measurements have been performed in accordance with (report available on request):
 - ETSI EN 301 489-17 V2.2.1 (2012-09)
 - ETSI EN 301 489-1 V1.9.2 (2011-09)
 - ETSI EN 300 328 V1.9.1 (2015-02)
 - EN 60950-1:2006+A11:2009 + A1:2010 + A12:2011 + A2:2013
 - EN 62479 (2010-09)

CE certified:

CE0051

11 Traceability

Each module is univocally identified by a serial number stored in a 2D data matrix laser marked on the bottom of the module.

The serial number has the following format: WW YY D FF NNN

Table 8: Traceability information

Letter	Meaning
WW	Week
YY	Year
D	Product ID number
FF	Production panel coordinate identification
NN	Progressive serial number

Each module bulk package is identified by a bulk ID.

The Bulk ID and module 2D data matrix are linked by a reciprocal traceability link.

The module 2D data matrix traces the lot number of any raw material used.

12 Ordering information

Table 9: Ordering information

Order code	Description	Packing	MOQ
SPBT3.0DP2	Class 2 OEM Bluetooth antenna module	JEDEC tray	2448 pcs

13 Revision history

Table 10: Document revision history

Date	Version	Changes
09-Jun-2016	1	Initial release.
28-Jun-2016	2	Updated cover page image Minor text edits
01-Jul-2016	3	In Table 6: Pin assignment - updated pin 6 description

IMPORTANT NOTICE – PLEASE READ CAREFULLY

STMicroelectronics NV and its subsidiaries ("ST") reserve the right to make changes, corrections, enhancements, modifications, and improvements to ST products and/or to this document at any time without notice. Purchasers should obtain the latest relevant information on ST products before placing orders. ST products are sold pursuant to ST's terms and conditions of sale in place at the time of order acknowledgement.

Purchasers are solely responsible for the choice, selection, and use of ST products and ST assumes no liability for application assistance or the design of Purchasers' products.

No license, express or implied, to any intellectual property right is granted by ST herein.

Resale of ST products with provisions different from the information set forth herein shall void any warranty granted by ST for such product.

ST and the ST logo are trademarks of ST. All other product or service names are the property of their respective owners.

Information in this document supersedes and replaces information previously supplied in any prior versions of this document.

© 2016 STMicroelectronics – All rights reserved