

## 6.0 Gbps SATA PC Board and Cable Equalizer

 Check for Samples: [SN75LVCP600DRF](#)

### FEATURES

- Multirate Operation, 1.5/3.0/6.0 Gbps
- Suitable to Receive 6.0 Gbps Data Over up to 40 Inches (1.0 meter) of FR4 PC Board
- Compensates up to 14dB Loss on the Receive Side and 1.2dB Loss on the Transmit Side at 3 GHz
- Integrated Output Squelch
- Auto Low Power Feature Lowers Power by >80% When Link is in Partial or Slumber Mode
  - <100 mW (Active Mode, typ)
  - <11 mW (Auto Low Power Mode, typ)

- Single 3.3 V Supply
- High Protection Against ESD Transient
  - HBM: 6,000 V
  - CDM: 1,500 V
- Ultra Small Footprint, 2x2 QFN Package

### APPLICATIONS

- Notebooks, Desktops, Docking Stations, Servers, Workstations

### DESCRIPTION

The SN75LVCP600 is a versatile single channel, SATA signal conditioner supporting data rates up to 6.0Gbps. The device complies with SATA physical link 2m and 3i specifications. The SN75LVCP600 operates from a single 3.3V supply and has 100-Ω line termination with self-biasing feature, making the device suitable for AC coupling. The inputs incorporate an out-of-band (OOB) detector, which automatically squelches the output when input differential voltage falls below threshold while maintaining a stable common-mode voltage compliant to SATA link. The device is also designed to handle spread spectrum clocking (SSC) transmission per SATA spec.

The SN75LVCP600 handles interconnect losses at its input with selectable equalization settings that can be programmed to match the loss in the channel. For data rates of 3Gbps and lower the LVCP600 equalizes signals for a span of up to 50 inches of FR4 board material. For data rates of 6Gbps the device compensates up to 40in of FR4 material. The equalization level is controlled by the setting of the signal control pin EQ.

Two de-emphasis levels can be selected on the transmit side to provide 0 or 1.2dB of additional high-frequency loss compensation at the output.

The device is hot-plug capable<sup>(1)</sup> preventing device damage under device *hot*-insertion such as async signal plug/removal, unpowered plug/removal, powered plug/removal, or surprise plug/removal.

(1) Requires use of AC coupling capacitors at differential inputs and outputs.

### ORDERING INFORMATION<sup>(1)</sup>

PART NUMBER	PART MARKING	PACKAGE
SN75LVCP600DRFR	600	8-Pin DRF reel (large)
SN75LVCP600DRFT	600	8-Pin DRF reel (small)

(1) For the most current package and ordering information, see the Package Option Addendum at the end of this document, or see the TI web site at [www.ti.com](http://www.ti.com).



Please be aware that an important notice concerning availability, standard warranty, and use in critical applications of Texas Instruments semiconductor products and disclaimers thereto appears at the end of this data sheet.



This integrated circuit can be damaged by ESD. Texas Instruments recommends that all integrated circuits be handled with appropriate precautions. Failure to observe proper handling and installation procedures can cause damage.

ESD damage can range from subtle performance degradation to complete device failure. Precision integrated circuits may be more susceptible to damage because very small parametric changes could cause the device not to meet its published specifications.

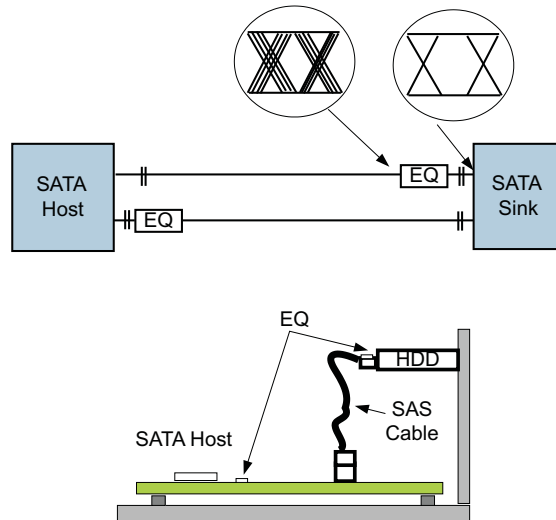

Figure 1. Typical Application

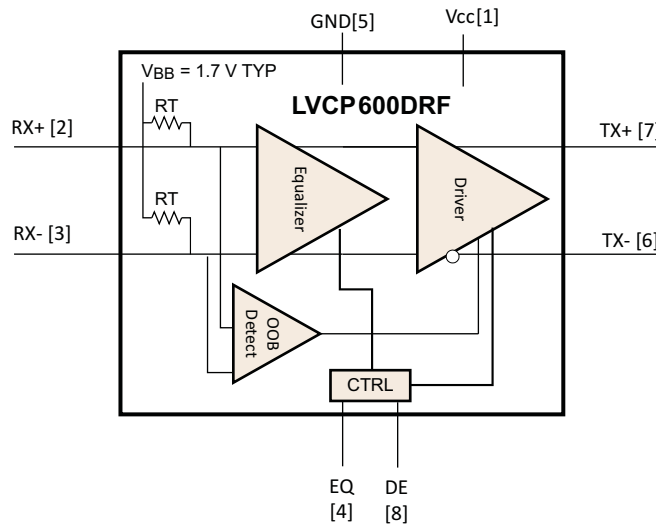
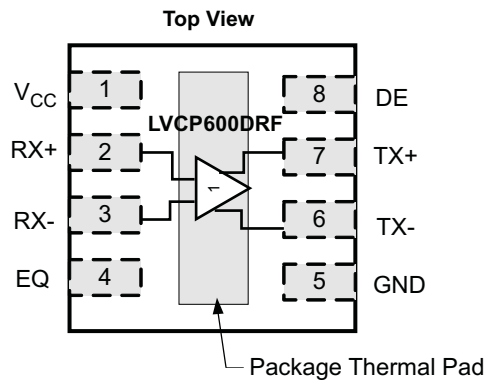

Figure 2. Data Flow Block Diagram

## PIN ASSIGNMENTS



## PIN FUNCTIONS

PIN		I/O TYPE	DESCRIPTION
NO.	NAME		
<b>HIGH SPEED DIFFERENTIAL I/O</b>			
2	RX+	I, VML	Non-inverting and inverting VML differential inputs. These pins are tied to an internal voltage bias by dual termination resistor circuit.
3	RX-	I, VML	
7	TX+	I, VML	Non-inverting and inverting VML differential outputs. These pins are tied to an internal voltage bias by dual termination resistor circuit.
6	TX-	I, VML	
<b>CONTROL PINS</b>			
4	EQ	I, LVCMOS	Selects equalization settings per <a href="#">Table 1</a> . Internally tied to GND.
8	DE	I, LVCMOS	Selects de-emphasis settings per <a href="#">Table 1</a> . Internally tied to GND.
<b>POWER</b>			
1	V <sub>CC</sub>	Power	Positive supply should be 3.3 V ±10%
5	GND	Power	Supply ground

**Table 1. EQ and DE Settings**

EQ	EQUALIZATION dB (at 6 Gbps)	DE	DE-EMPHASIS dB (at 6 Gbps)
0 ( <i>default</i> )	7	0 ( <i>default</i> )	0
1	14	1	-1.2

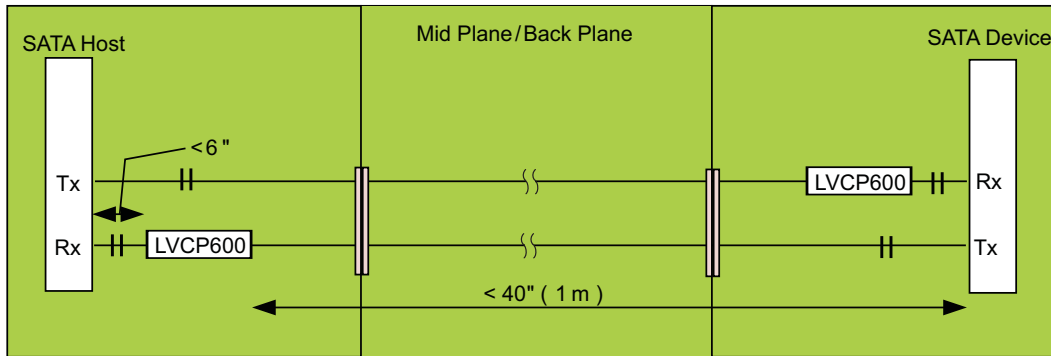

**Note:**

Trace lengths are suggested values based on TI HSPICE simulations (done over programmable limits of input EQ) to meet SATA loss and jitter spec.

Actual trace length supported by the LVCP600 may be more or less than suggested values and will depend on board layout, trace widths and number of connectors used in the high speed signal path.

**Figure 3. Trace Length Example**

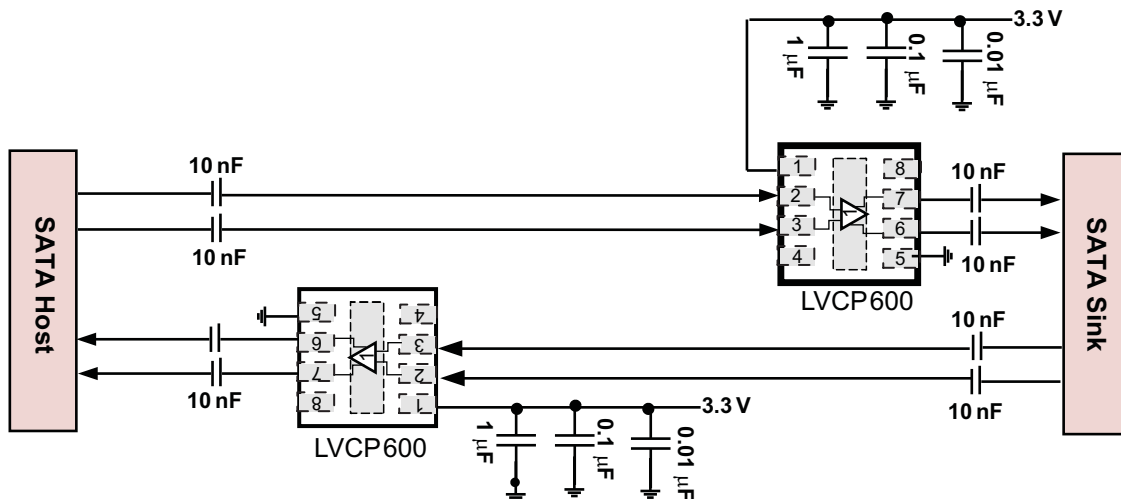

**Note:**

- 1) Place supply caps close to device pin
- 2) EQ and DE selection at 7 dB and 0dB respectively
- 3) Actual EQ/DE settings will depend on device placement relative to host and SATA connector

**Figure 4. Typical Device Implementation**

The LVCP600 allows user to take the guess work of using a signal conditioning device in a SATA link. With the LVCP600 user has the option to use or remove the device based on signal conditioning needs. See [Figure 5](#).

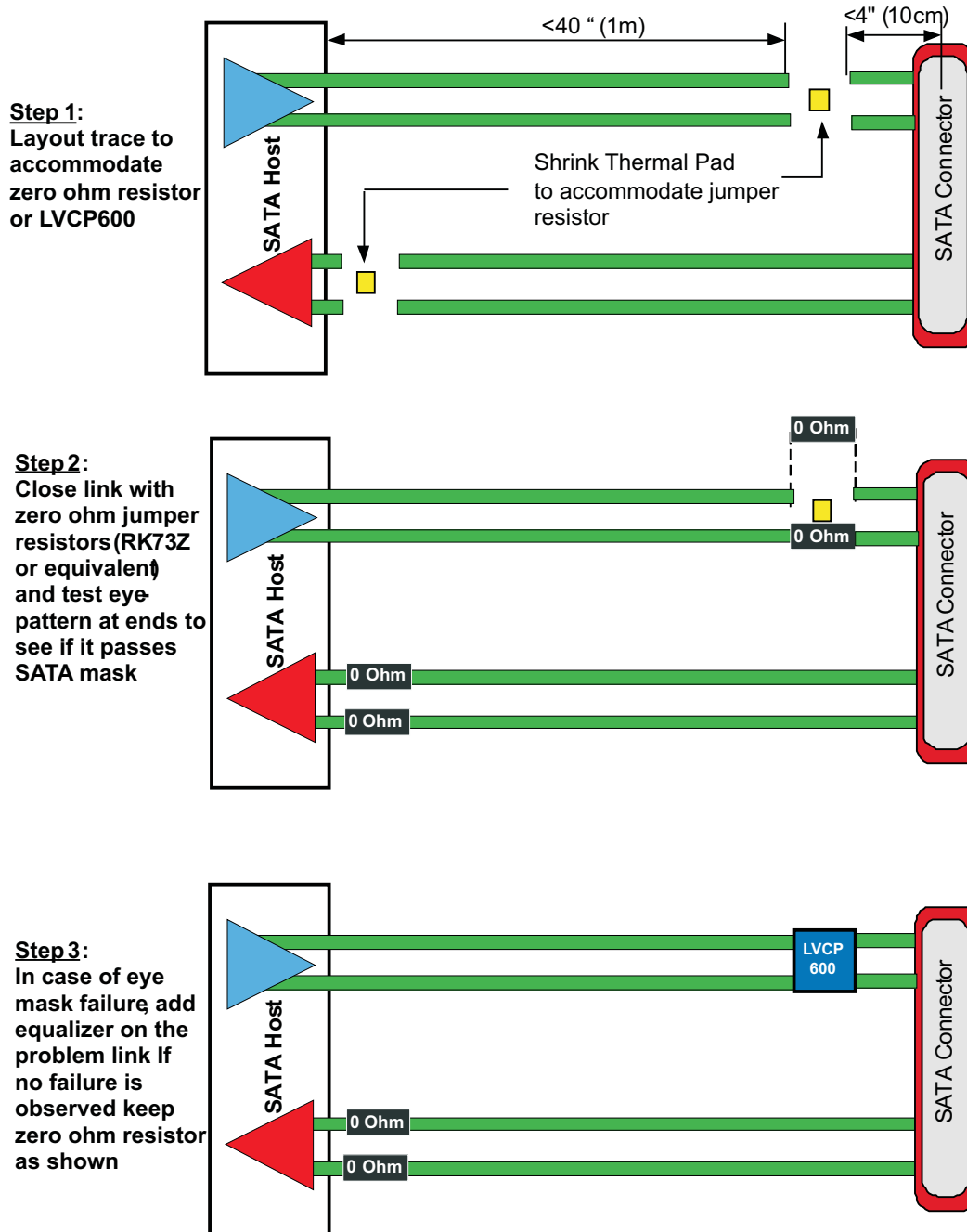

Figure 5. Implementation Guideline

## OPERATION DESCRIPTION

### INPUT EQUALIZATION

The SN75LVCP600 supports programmable equalization in its front stage; the equalization settings are shown in Table 1. The input equalizer is designed to recover a signal even when no eye is present at the receiver and will affectively support FR4 trace at the input anywhere from 4" to 40" at SATA 6G speed.

## AUTO LOW POWER (ALP) MODE (see Figure 10)

Auto Low Power (ALP) Mode is triggered when a channel is in the electrical idle state for >10  $\mu$ s.

- The device enters and exits Low Power Mode by actively monitoring input signal ( $VID_{pp}$ ) level. When the input signal is in the electrical idle state, i.e.,  $VID_{pp} < 50$  mV and stays in this state for >10  $\mu$ s, the device automatically enters the low power state. In this state the output is driven to VCM and the device selectively shuts off internal circuitry to lower power by >90% of its normal operating power. While in ALP mode the device continues actively to monitor input signal levels. When the input signal exceeds the SATA OOB upper threshold level, the device reverts to the active state. Exit time from Auto Low Power Mode is <50 ns (max).

## OUT-OF-BAND (OOB) SUPPORT

The squelch detector circuit within the device enables full detection of OOB signaling as specified in the SATA spec. When differential signal amplitude at the receiver input is 50 mV<sub>pp</sub> or less, the output is squelched. Differential signal amplitude of 90 mV<sub>pp</sub> or more is detected as an activity and therefore passed to the output indicating activity. Squelch circuit ON/OFF time is 5 ns max. While in squelch mode outputs are held to VCM.

## DEVICE POWER

The SN75LVCP600 is designed to operate from a single 3.3 V supply. Always practice proper power supply sequencing procedure. Apply  $V_{CC}$  first before any input signals are applied to the device. The power down sequence is in reverse order.

## ABSOLUTE MAXIMUM RATINGS

over operating free-air temperature range (unless otherwise noted)<sup>(1)</sup>

		VALUE	UNIT
Supply voltage range <sup>(2)</sup>	$V_{CC}$	-0.5 to 4	V
Voltage range	Differential I/O	-0.5 to 4	V
	Control I/O	-0.5 to $V_{CC} + 0.5$	V
Electrostatic discharge	Human body model <sup>(3)</sup>	$\pm 6000$	V
	Charged-device model <sup>(4)</sup>	$\pm 1500$	V
	Machine model <sup>(5)</sup>	$\pm 200$	V
Continuous power dissipation		See Dissipation Rating Table	

- Stresses beyond those listed under absolute maximum ratings may cause permanent damage to the device. These are stress ratings only and functional operation of the device at these or any conditions beyond those indicated under recommended operating conditions is not implied. Exposure to absolute-maximum-rated conditions for extended periods may affect device reliability.
- All voltage values, except differential voltages, are with respect to network ground terminal.
- Tested in accordance with JEDEC Standard 22, Test Method A114-B.
- Tested in accordance with JEDEC Standard 22, Test Method C101-A.
- Tested in accordance with JEDEC Standard 22, Test Method A115-A.

## THERMAL INFORMATION

THERMAL METRIC <sup>(1)</sup>		SN75LVCP600	UNITS
		DRF (8) PINS	
$\theta_{JA}$	Junction-to-ambient thermal resistance	97.8	°C/W
$\theta_{JCTop}$	Junction-to-case (top) thermal resistance	81.9	
$\theta_{JB}$	Junction-to-board thermal resistance	65.6	
$\psi_{JT}$	Junction-to-top characterization parameter	1.3	
$\psi_{JB}$	Junction-to-board characterization parameter	65.6	
$\theta_{JCbott}$	Junction-to-case (bottom) thermal resistance	19.1	

- For more information about traditional and new thermal metrics, see the *IC Package Thermal Metrics* application report, [SPRA953](#).

## RECOMMENDED OPERATING CONDITIONS

typical values for all parameters are at  $V_{CC} = 3.3\text{ V}$  and  $T_A = 25^\circ\text{C}$ ; all temperature limits are specified by design

PARAMETER		TEST CONDITIONS	MIN	TYP	MAX	UNITS
$V_{CC}$	Supply voltage		3	3.3	3.6	V
$C_{COUPLING}$	Coupling capacitor			12		nF
$T_A$	Operating free-air temperature		0		85	$^\circ\text{C}$

## ELECTRICAL CHARACTERISTICS

over recommended operating conditions (unless otherwise noted)

PARAMETER		TEST CONDITIONS	MIN	TYP	MAX	UNITS
<b>DEVICE PARAMETERS</b>						
$I_{CCMax}$	Active mode supply current	EQ/DE = NC, K28.5 pattern at 6 Gbps, $V_{ID} = 700\text{ mV}_{pp}$		29	40	mA
$I_{CCPS}$	Auto power save mode $I_{CC}$	When auto low power conditions are met		3.3	5.9	mA
	Maximum data rate				6.0	Gbps
$t_{PDelay}$	Propagation delay	Measured using K28.5 pattern, See <a href="#">Figure 8</a>		275	350	ps
AutoLP <sub>ENTRY</sub>	Auto low power entry time	Electrical idle at input, See <a href="#">Figure 10</a>		11		$\mu\text{s}$
AutoLP <sub>EXIT</sub>	Auto low power exit time	After first signal activity, See <a href="#">Figure 10</a>		33	50	ns
<b>OOB</b>						
$V_{OOB}$	Input OOB threshold	$F = 750\text{ MHz}$	50	70	90	$\text{mV}_{pp}$
$D_{VdiffOOB}$	OOB differential delta				25	mV
$D_{VCMOOB}$	OOB common-mode delta				50	mV
$t_{OOB1}$	OOB mode enter	See <a href="#">Figure 9</a>		1	5	ns
$t_{OOB2}$	OOB mode exit	See <a href="#">Figure 9</a>		1	5	ns
<b>CONTROL LOGIC</b>						
$V_{IH}$	High-level input voltage	For all control pins	1.4			V
$V_{IL}$	Low-level input voltage				0.5	V
$V_{INHYS}$	Input hysteresis			115		mV
$I_{IH}$	High-level input current	$V_{IH} = V_{CC}$ (DE/EQ)			20	$\mu\text{A}$
$I_{IL}$	Low-level input current	$V_{IL} = 0\text{V}$ (DE/EQ)			10	$\mu\text{A}$
<b>RECEIVER AC/DC</b>						
$Z_{DIFFRX}$	Differential input impedance		85	100	115	$\Omega$
$Z_{SERX}$	Single-ended input impedance		40			$\Omega$
$V_{CMRX}$	Common-mode voltage			1.7		V
$RL_{DIFFRX}$	Differential mode return loss (RL)	$f = 150\text{ MHz} - 300\text{ MHz}$	18	26		dB
		$f = 300\text{ MHz} - 600\text{ MHz}$	14	22		
		$f = 600\text{ MHz} - 1.2\text{ GHz}$	10	17		
		$f = 1.2\text{ GHz} - 2.4\text{ GHz}$	8	12		
		$f = 2.4\text{ GHz} - 3.0\text{ GHz}$	3	11		
$RX_{DIFFRLSlope}$	Differential mode RL slope	$f = 300\text{ MHz} - 6.0\text{ GHz}$ (see <a href="#">Figure 6</a> )		-13		dB/dec
$RL_{CMRX}$	Common-mode return loss	$f = 150\text{ MHz} - 300\text{ MHz}$	5	9.4		dB
		$f = 300\text{ MHz} - 600\text{ MHz}$	5	17		
		$f = 600\text{ MHz} - 1.2\text{ GHz}$	2	18		
		$f = 1.2\text{ GHz} - 2.4\text{ GHz}$	1	9.9		
		$f = 2.4\text{ GHz} - 3.0\text{ GHz}$	1	8.6		
$V_{diffRX}$	Differential input voltage PP	$f = 1.5\text{ GHz}$ and $3.0\text{ GHz}$	120		1600	$\text{mV/ppd}$

**ELECTRICAL CHARACTERISTICS (continued)**

over recommended operating conditions (unless otherwise noted)

PARAMETER		TEST CONDITIONS	MIN	TYP	MAX	UNITS
IB <sub>RX</sub>	Impedance balance	f = 150 MHz–300 MHz	30	41		dB
		f = 300 MHz–600 MHz	30	41		
		f = 600 MHz–1.2 GHz	20	34		
		f = 1.2 GHz–2.4 GHz	10	24		
		f = 2.4 GHz–3.0 GHz	10	26		
		f = 3.0 GHz–5.0 GHz	4	18		
		f = 5.0 GHz–6.5 GHz	4	18		
T <sub>20-80RX</sub>	Rise/fall time	Rise times and fall times measured between 20% and 80% of the signal. SATA 6 Gbps speed measured 1" from device pin	62		75	ps
T <sub>skewRX</sub>	Differential skew	Difference between the single-ended mid-point of the RX+ signal rising/falling edge, and the single-ended mid-point of the RX– signal falling/rising edge			30	ps
<b>TRANSMITTER AC/DC</b>						
Z <sub>diffTX</sub>	Pair differential impedance		85	100	122	Ω
Z <sub>SETX</sub>	Single-ended input impedance		40			Ω
V <sub>Txtrans</sub>	Sequencing transient voltage	Transient voltages on the serial data bus during power sequencing (lab load)	–1.2	0.3	1.2	V
RL <sub>DiffTX</sub>	Differential mode return loss	f = 150 MHz–300 MHz	13	22		dB
		f = 300 MHz–600 MHz	8	21		
		f = 600 MHz–1.2 GHz	6	19		
		f = 1.2 GHz–2.4 GHz	6	14		
		f = 2.4 GHz–3.0 GHz	3	14		
TX <sub>DiffRLSlope</sub>	Differential mode RL slope	f = 300 MHz – 3.0 GHz (see <a href="#">Figure 6</a> )		–13		dB/dec
RL <sub>CMTX</sub>	Common-mode return loss	f = 150 MHz–300 MHz	5	20		dB
		f = 300 MHz–600 MHz	5	16		
		f = 600 MHz–1.2 GHz	2	13		
		f = 1.2 GHz–2.4 GHz	1	8		
		f = 2.4 GHz–3.0 GHz	1	8		
IB <sub>TX</sub>	Impedance balance	f = 150 MHz–300 MHz	30	38		dB
		f = 300 MHz–600 MHz	30	38		
		f = 600 MHz–1.2 GHz	20	33		
		f = 1.2 GHz–2.4 GHz	10	25		
		f = 2.4 GHz–3.0 GHz	10	25		
		f = 3.0 GHz–5.0 GHz	4	21		
		f = 5.0 GHz–6.5 GHz	4	21		
Diff <sub>VppTX</sub>	Differential output voltage swing	f = 3.0 GHz (under no interconnect loss)	400	650	900	mV/ppd
VCM <sub>AC_TX</sub>	TX AC CM voltage	At 1.5 GHz		15	50	mV/ppd
		At 3.0 GHz		10	26	dBmv (rms)
		At 6.0 GHz		12	30	
VCM <sub>TX</sub>	Common-mode voltage			1.70		V
T <sub>20-80TX</sub>	Rise/Fall time	Rise times and fall times measured between 20% and 80% of the signal. At 6Gbps under no load conditions measured at the pin	44	58	85	ps
T <sub>skewTX</sub>	Differential skew	Difference between the single-ended mid-point of the TX+ signal rising/falling edge, and the single-ended mid-point of the TX– signal falling/rising edge, D1, D0 = V <sub>CC</sub>		2	20	ps
TxR/F <sub>Imb</sub>	TX rise/fall imbalance	At 3 Gbps		6%	20%	
TxA <sub>mplmb</sub>	TX amplitude imbalance			1%	10%	

### ELECTRICAL CHARACTERISTICS (continued)

over recommended operating conditions (unless otherwise noted)

PARAMETER		TEST CONDITIONS	MIN	TYP	MAX	UNITS
<b>TRANSMITTER JITTER<sup>(1)</sup></b>						
DJ <sub>TX</sub>	Residual deterministic jitter	VID = 500 mV <sub>pp</sub> , UI = 333 ps, K28.5 control character, See Figure 7	0.12	0.19		UI <sub>pp</sub>
RJ <sub>TX</sub>	Random jitter	VID = 500 mV <sub>pp</sub> , UI = 333 ps, K28.7 control character, See Figure 7	1.0	2.0		ps-rms
DJ <sub>TX</sub>	Residual deterministic jitter	VID = 500 mV <sub>pp</sub> , UI = 167 ps, K28.5 control character, See Figure 7	0.12	0.34		UI <sub>pp</sub>
RJ <sub>TX</sub>	Random jitter	VID = 500 mV <sub>pp</sub> , UI = 167 ps, K28.7 control character, See Figure 7	0.95	2.0		ps-rms

(1)  $T_J = (14.1 \times RJ_{SD} + DJ)$  where  $RJ_{SD}$  is one standard deviation value of RJ Gaussian distribution. Jitter measurement is at the SATA connector and includes jitter generated at the package connection on the printed circuit board, and at the board interconnect as shown in Figure 7.

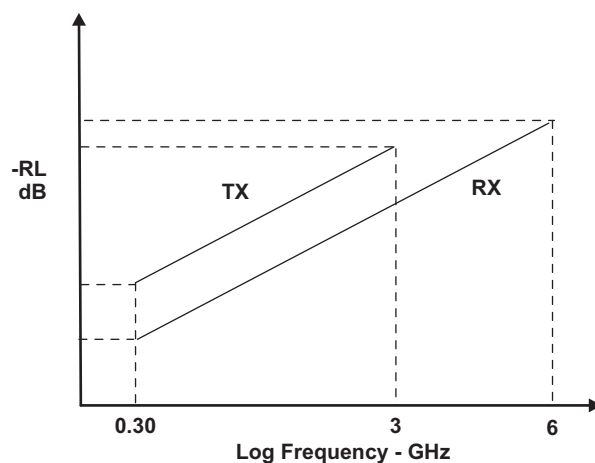

Figure 6. TX, RX Differential Return Loss Limits

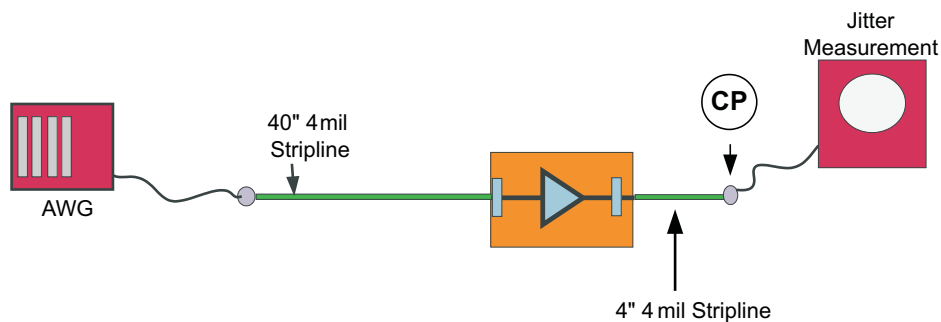

Figure 7. Jitter Measurement Test Condition

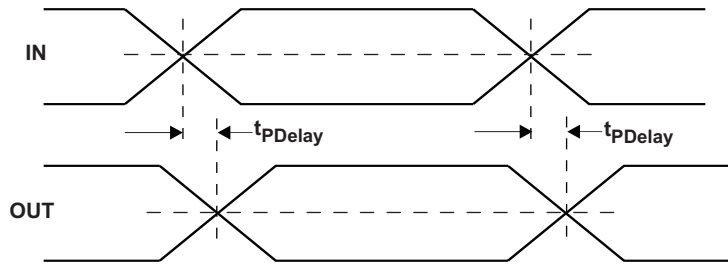

Figure 8. Propagation Delay Timing Diagram

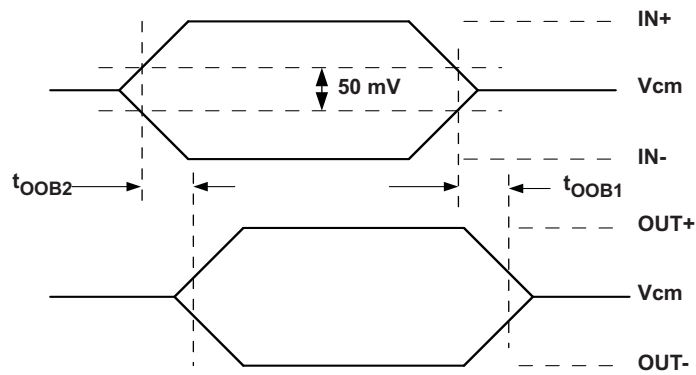

Figure 9. OOB Enter and Exit Timing

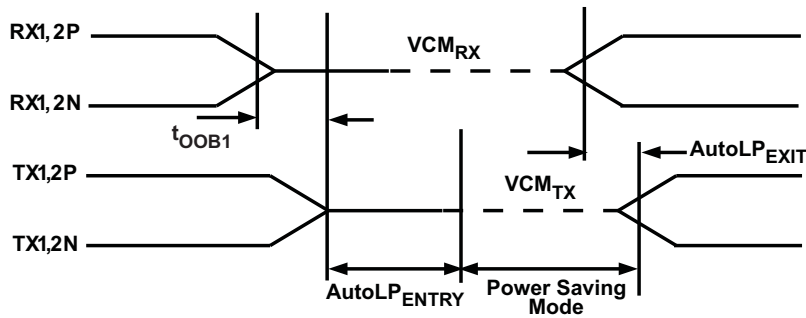

Figure 10. Auto Low Power Mode Entry and Exit Timing

APPLICATION INFORMATION

Figure 12 through Figure 24 show LVCP600 typical performance plots when connected to various trace lengths with  $V_{CC} = 3.3\text{ V}$  and  $T_A = 25^\circ\text{C}$ . All eye diagrams measured using K28.5 pattern at 6 Gbps. Setup for the performance plots is shown in Figure 11.

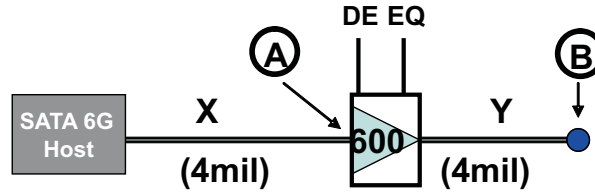

Figure 11. Test Points

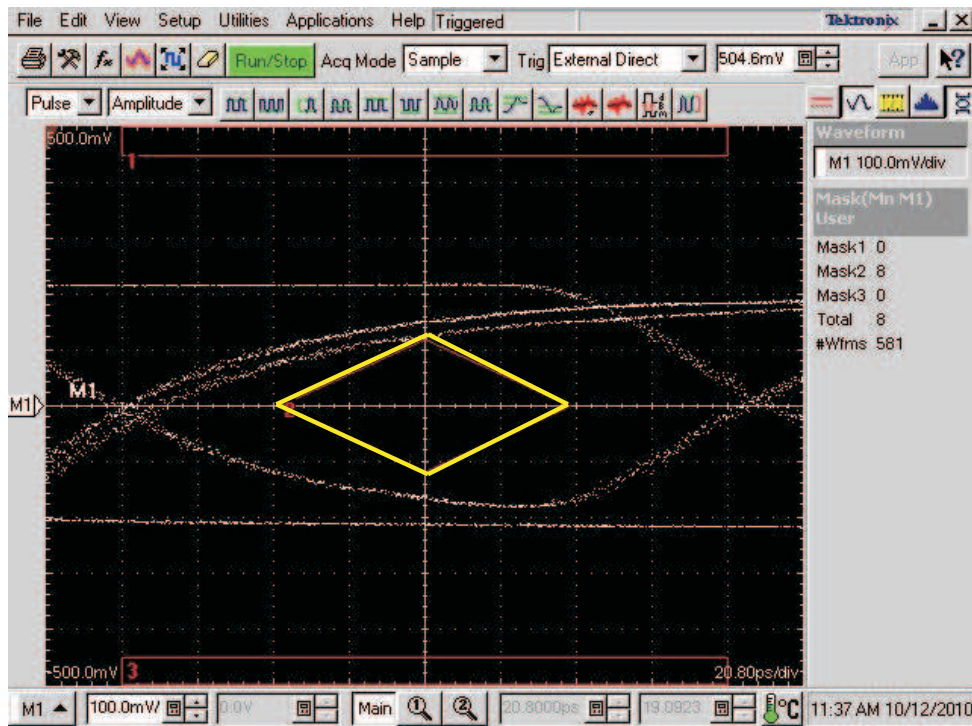

Figure 12. Eye Pattern at A → X= 8"; Y = 2" DE = 1 EQ = 0

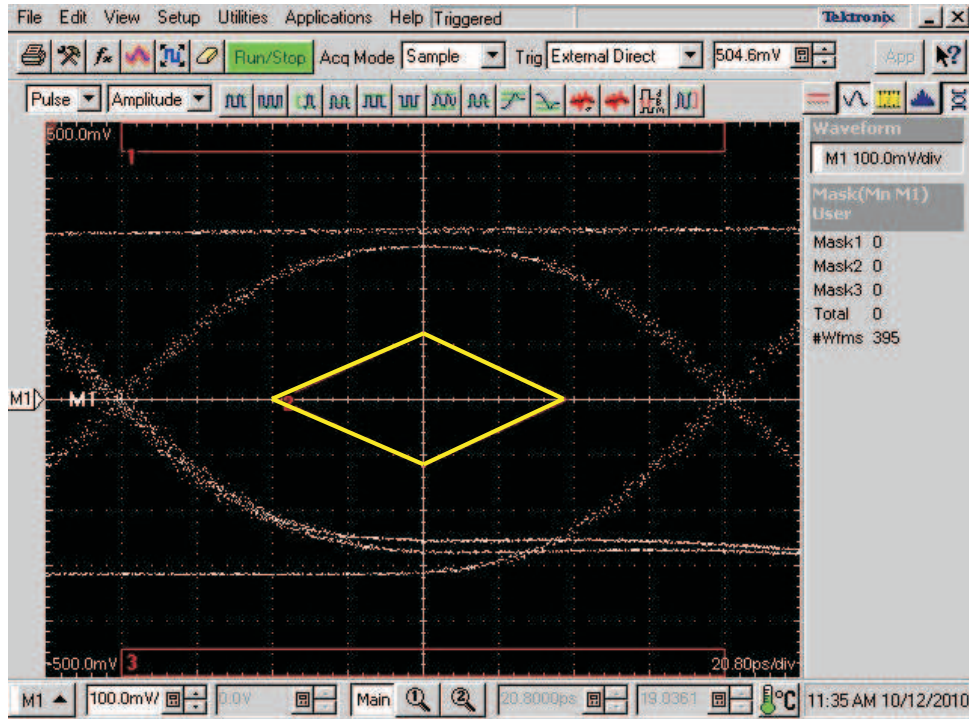

Figure 13. Eye Pattern at B → X= 8"; Y = 2" DE = 1 EQ = 0

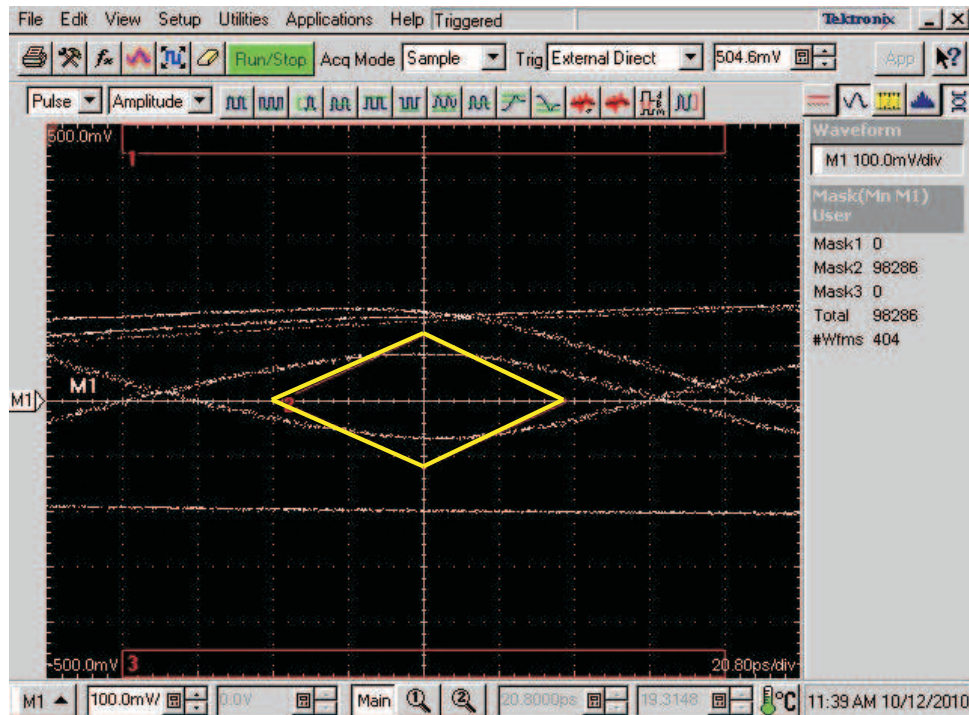

Figure 14. Eye Pattern at A → X= 16"; Y = 2" DE = 1 EQ = 0

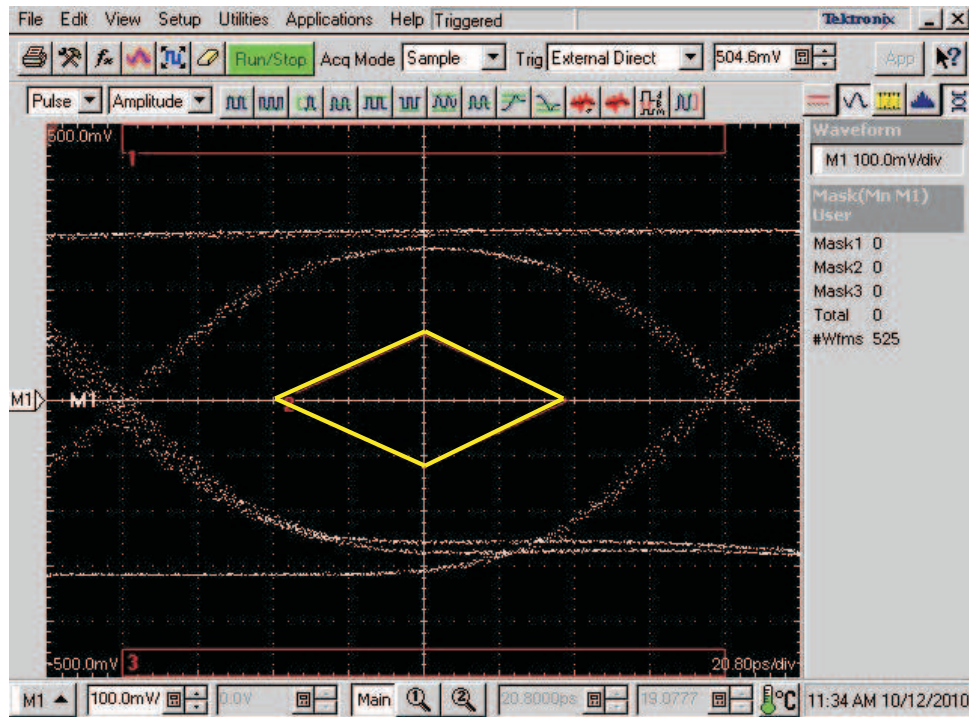

Figure 15. Eye Pattern at B → X= 16"; Y = 2" DE = 1 EQ = 0

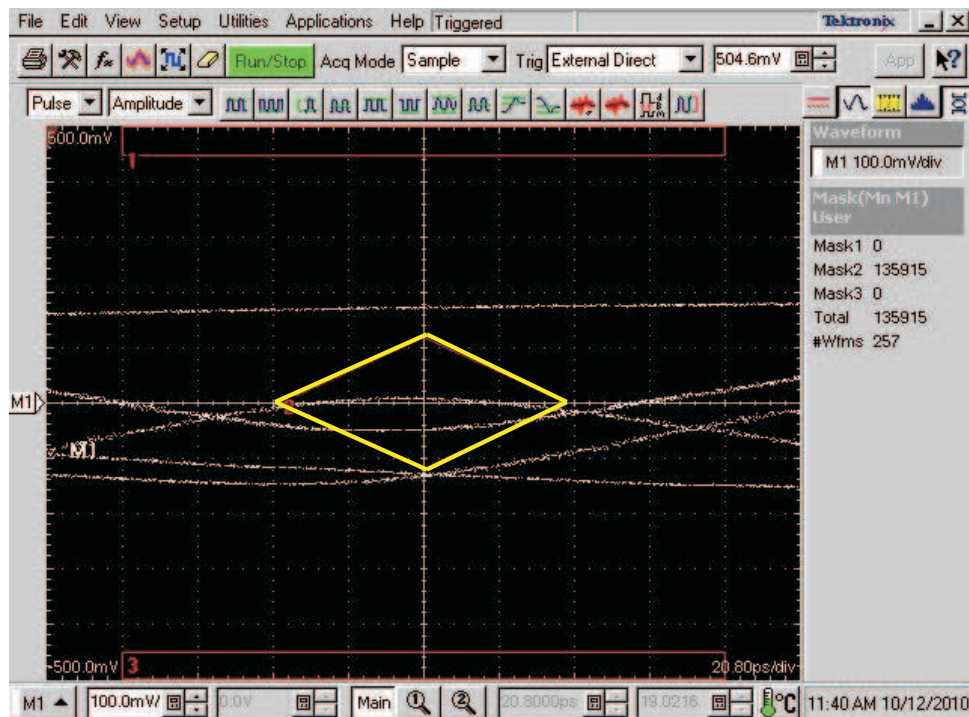

Figure 16. Eye Pattern at A → X= 24"; Y = 2" DE = 1 EQ = 0

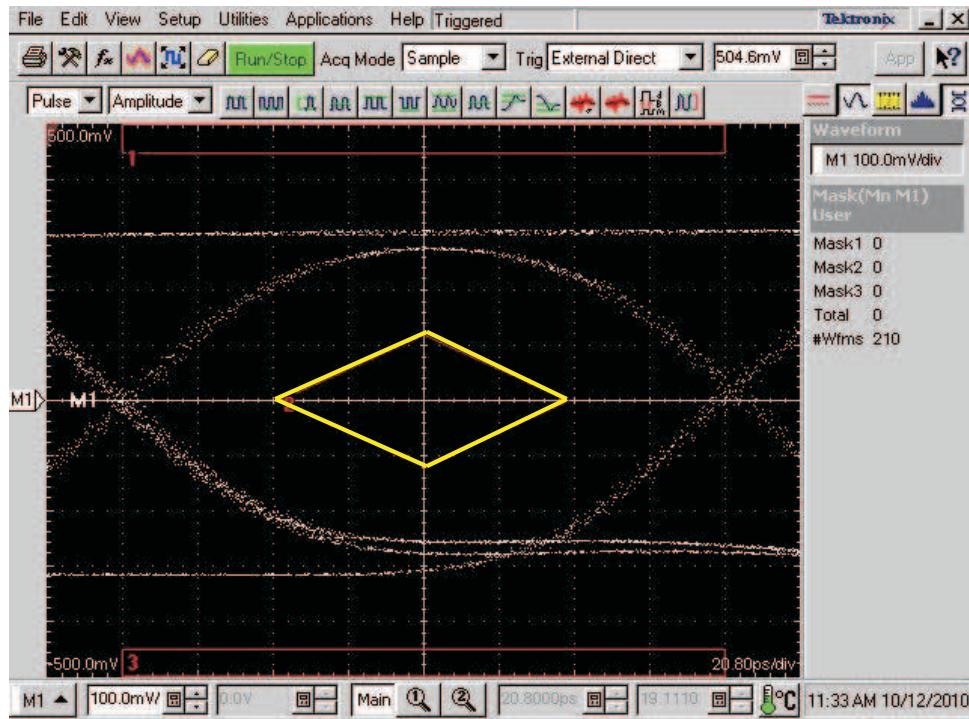

Figure 17. Eye Pattern at B → X= 24"; Y = 2" DE = 1 EQ = 0

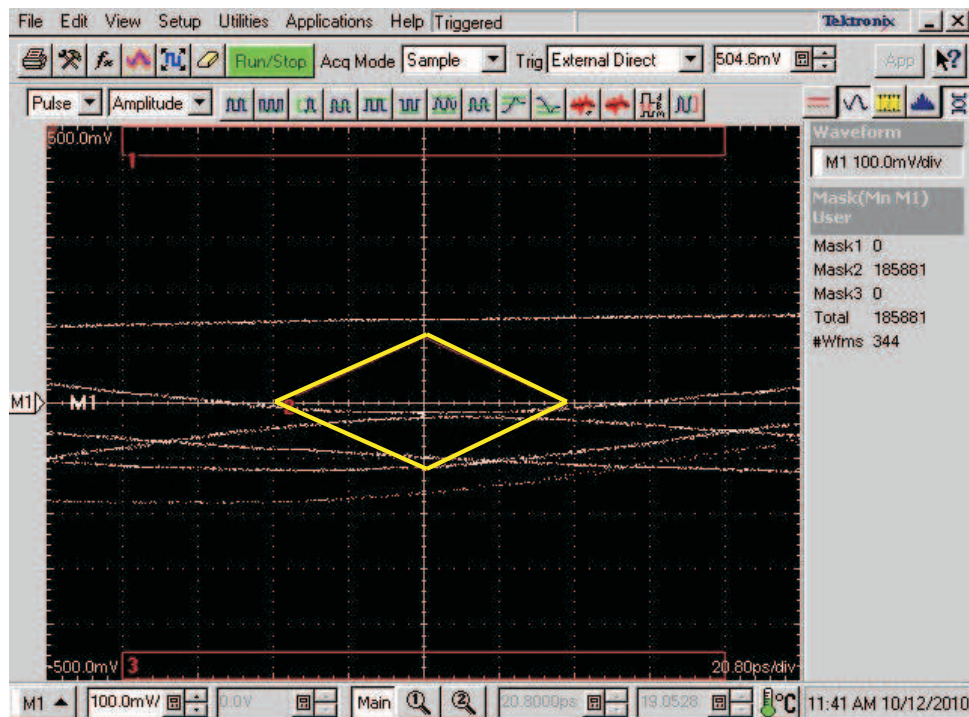

Figure 18. Eye Pattern at A → X= 32"; Y = 2" DE = 1 EQ = 1

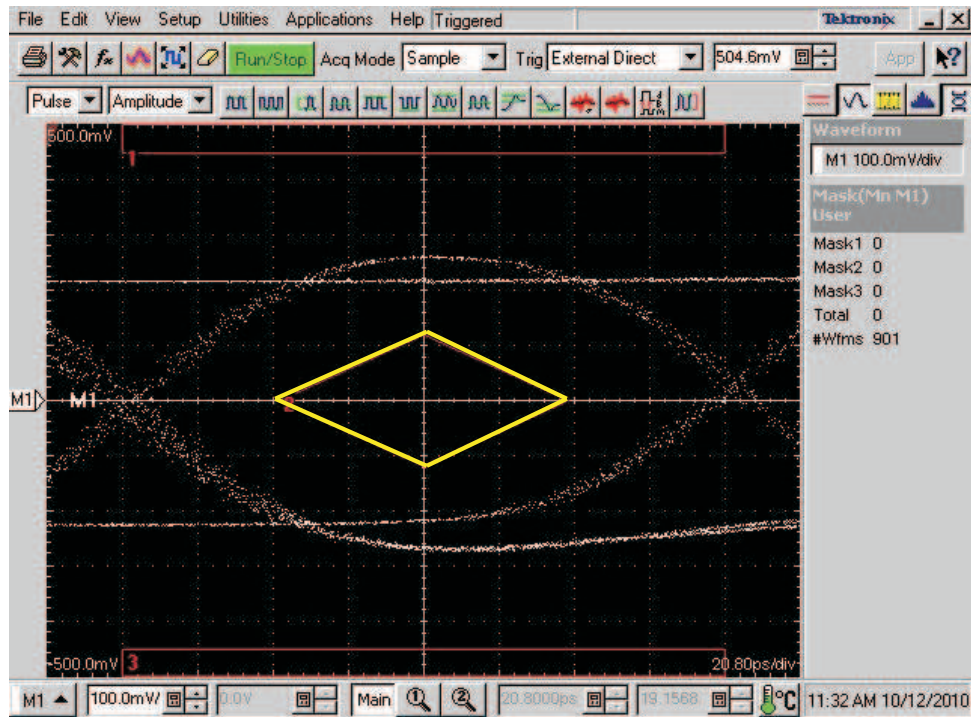

Figure 19. Eye Pattern at B → X= 32"; Y = 2" DE = 1 EQ = 1

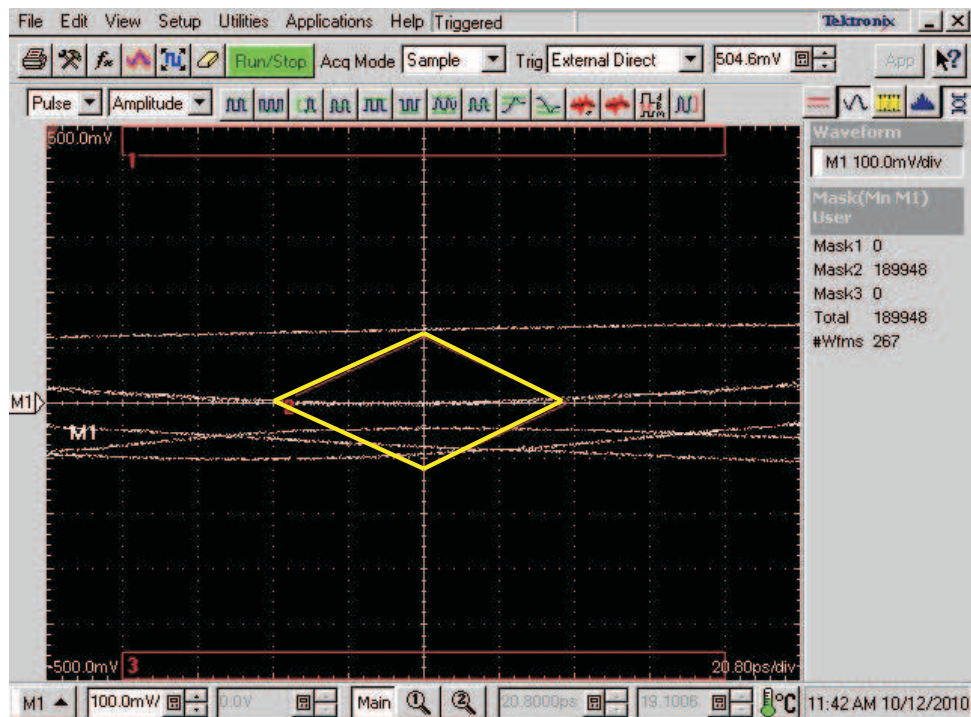

Figure 20. Eye Pattern at A → X= 40"; Y = 2" DE = 1 EQ = 1

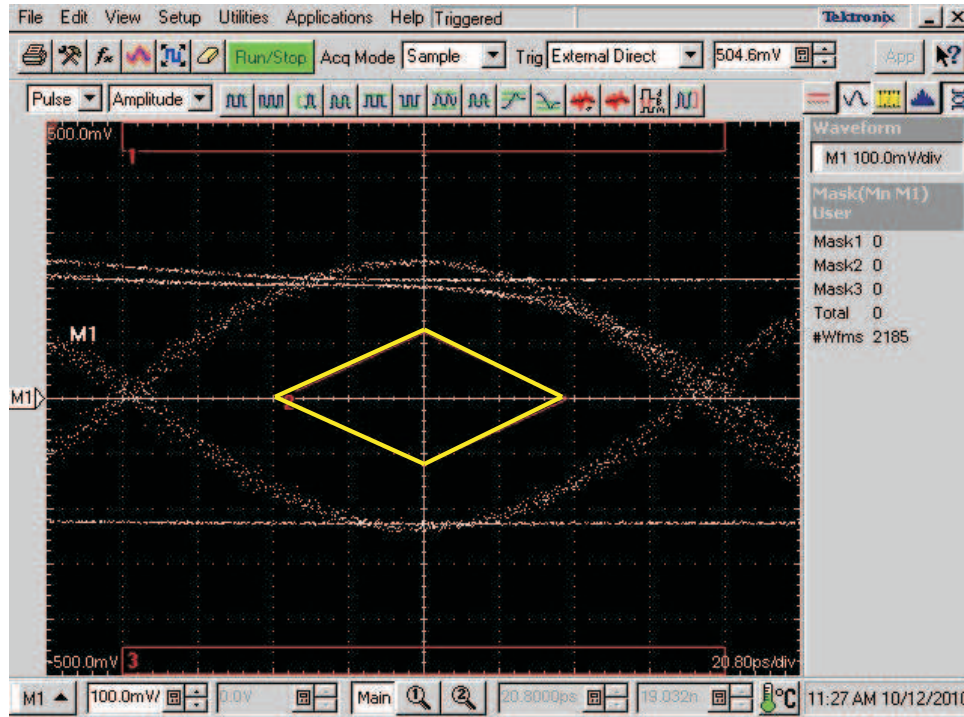

Figure 21. Eye Pattern at B → X= 40"; Y = 2" DE = 1 EQ = 1

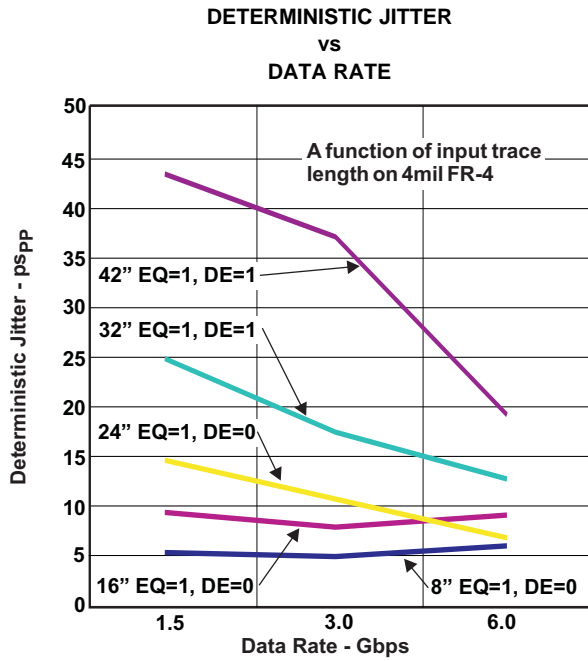

Figure 22.

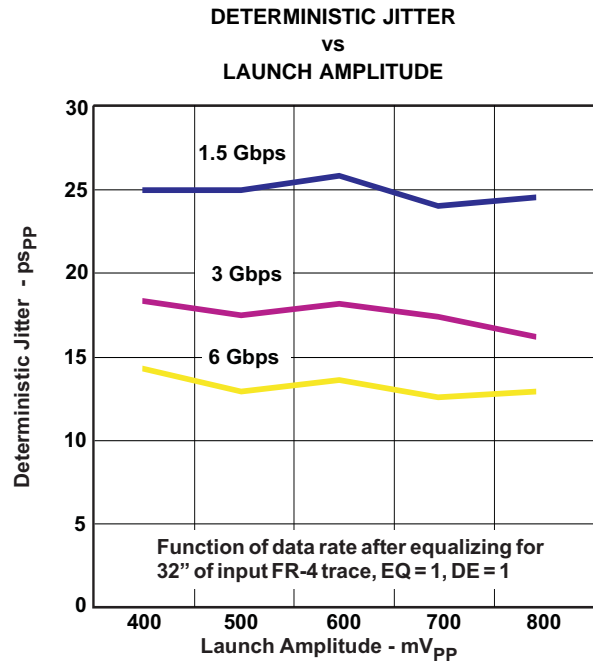
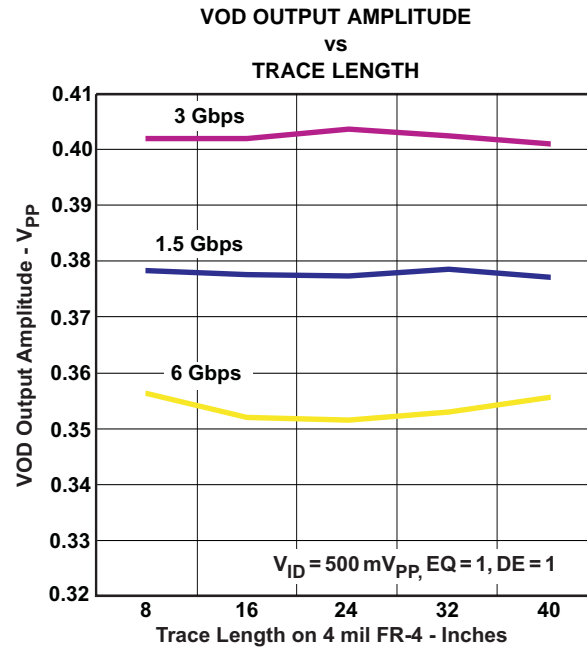

Figure 23.



**Figure 24.**

**PACKAGING INFORMATION**

Orderable Device	Status <sup>(1)</sup>	Package Type	Package Drawing	Pins	Package Qty	Eco Plan <sup>(2)</sup>	Lead/ Ball Finish	MSL Peak Temp <sup>(3)</sup>	Samples (Requires Login)
SN75LVCP600DRFR	ACTIVE	WSON	DRF	8	3000	Green (RoHS & no Sb/Br)	CU NIPDAU	Level-2-260C-1 YEAR	<a href="#">Purchase Samples</a>
SN75LVCP600DRFT	ACTIVE	WSON	DRF	8	250	Green (RoHS & no Sb/Br)	CU NIPDAU	Level-2-260C-1 YEAR	<a href="#">Purchase Samples</a>

<sup>(1)</sup> The marketing status values are defined as follows:

**ACTIVE:** Product device recommended for new designs.

**LIFEBUY:** TI has announced that the device will be discontinued, and a lifetime-buy period is in effect.

**NRND:** Not recommended for new designs. Device is in production to support existing customers, but TI does not recommend using this part in a new design.

**PREVIEW:** Device has been announced but is not in production. Samples may or may not be available.

**OBsolete:** TI has discontinued the production of the device.

<sup>(2)</sup> Eco Plan - The planned eco-friendly classification: Pb-Free (RoHS), Pb-Free (RoHS Exempt), or Green (RoHS & no Sb/Br) - please check <http://www.ti.com/productcontent> for the latest availability information and additional product content details.

**TBD:** The Pb-Free/Green conversion plan has not been defined.

**Pb-Free (RoHS):** TI's terms "Lead-Free" or "Pb-Free" mean semiconductor products that are compatible with the current RoHS requirements for all 6 substances, including the requirement that lead not exceed 0.1% by weight in homogeneous materials. Where designed to be soldered at high temperatures, TI Pb-Free products are suitable for use in specified lead-free processes.

**Pb-Free (RoHS Exempt):** This component has a RoHS exemption for either 1) lead-based flip-chip solder bumps used between the die and package, or 2) lead-based die adhesive used between the die and leadframe. The component is otherwise considered Pb-Free (RoHS compatible) as defined above.

**Green (RoHS & no Sb/Br):** TI defines "Green" to mean Pb-Free (RoHS compatible), and free of Bromine (Br) and Antimony (Sb) based flame retardants (Br or Sb do not exceed 0.1% by weight in homogeneous material)

<sup>(3)</sup> MSL, Peak Temp. -- The Moisture Sensitivity Level rating according to the JEDEC industry standard classifications, and peak solder temperature.

**Important Information and Disclaimer:** The information provided on this page represents TI's knowledge and belief as of the date that it is provided. TI bases its knowledge and belief on information provided by third parties, and makes no representation or warranty as to the accuracy of such information. Efforts are underway to better integrate information from third parties. TI has taken and continues to take reasonable steps to provide representative and accurate information but may not have conducted destructive testing or chemical analysis on incoming materials and chemicals. TI and TI suppliers consider certain information to be proprietary, and thus CAS numbers and other limited information may not be available for release.

In no event shall TI's liability arising out of such information exceed the total purchase price of the TI part(s) at issue in this document sold by TI to Customer on an annual basis.

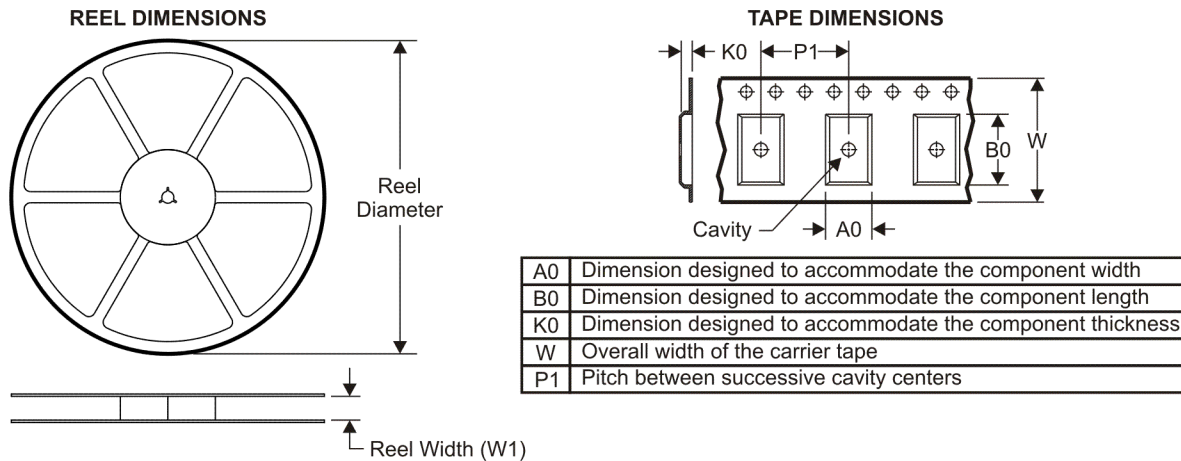
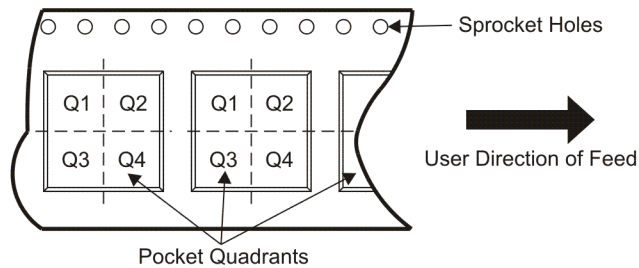
**TAPE AND REEL INFORMATION**

**QUADRANT ASSIGNMENTS FOR PIN 1 ORIENTATION IN TAPE**

\*All dimensions are nominal

Device	Package Type	Package Drawing	Pins	SPQ	Reel Diameter (mm)	Reel Width W1 (mm)	A0 (mm)	B0 (mm)	K0 (mm)	P1 (mm)	W (mm)	Pin1 Quadrant
SN75LVCP600DRFR	WSON	DRF	8	3000	330.0	12.4	2.2	2.2	1.1	8.0	12.0	Q2
SN75LVCP600DRFT	WSON	DRF	8	250	180.0	12.4	2.2	2.2	1.1	8.0	12.0	Q2

**TAPE AND REEL BOX DIMENSIONS**



\*All dimensions are nominal

Device	Package Type	Package Drawing	Pins	SPQ	Length (mm)	Width (mm)	Height (mm)
SN75LVCP600DRFR	WSON	DRF	8	3000	346.0	346.0	29.0
SN75LVCP600DRFT	WSON	DRF	8	250	190.5	212.7	31.8

DRF (S-PWSON-N8)

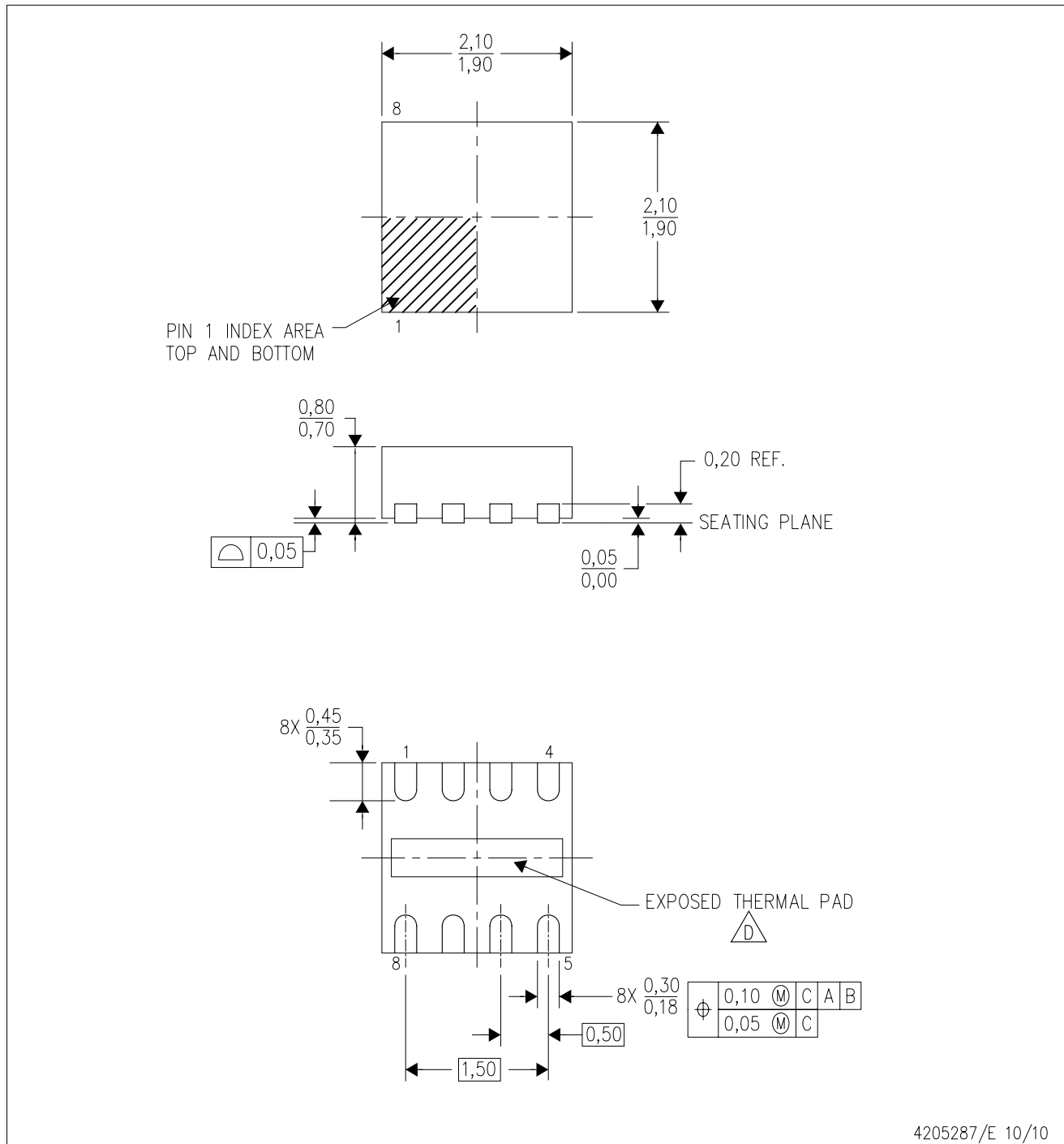
PLASTIC SMALL OUTLINE NO-LEAD



- NOTES:
- A. All linear dimensions are in millimeters. Dimensioning and tolerancing per ASME Y14.5M-1994.
  - B. This drawing is subject to change without notice.
  - C. Quad Flatpack, No-Leads (QFN) package configuration.
  -  D. The Package thermal pad must be soldered to the board for thermal and mechanical performance. See product data sheet for details regarding the exposed thermal pad dimensions.
  - E. Falls within JEDEC MO-229.

# THERMAL PAD MECHANICAL DATA

DRF (S-PWSON-N8)

PLASTIC SMALL OUTLINE NO-LEAD

## THERMAL INFORMATION

This package incorporates an exposed thermal pad that is designed to be attached directly to an external heatsink. The thermal pad must be soldered directly to the printed circuit board (PCB). After soldering, the PCB can be used as a heatsink. In addition, through the use of thermal vias, the thermal pad can be attached directly to the appropriate copper plane shown in the electrical schematic for the device, or alternatively, can be attached to a special heatsink structure designed into the PCB. This design optimizes the heat transfer from the integrated circuit (IC).

For information on the Quad Flatpack No-Lead (QFN) package and its advantages, refer to Application Report, QFN/SOIC PCB Attachment, Texas Instruments Literature No. SLUA271. This document is available at [www.ti.com](http://www.ti.com).

The exposed thermal pad dimensions for this package are shown in the following illustration.

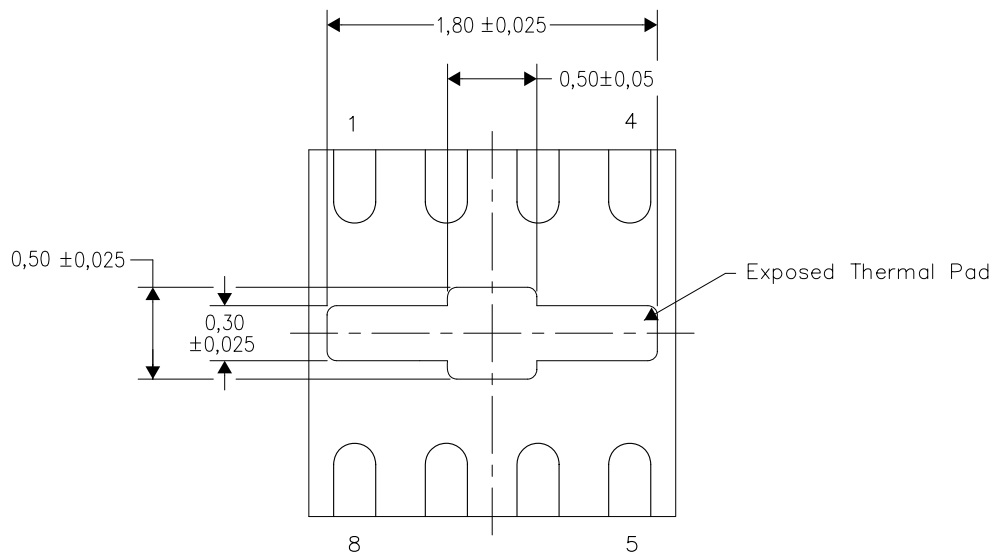

Bottom View

Exposed Thermal Pad Dimensions

4206840/G 04/11

NOTE: A. All linear dimensions are in millimeters

DRF (S-PWSON-N8)

PLASTIC SMALL OUTLINE NO-LEAD

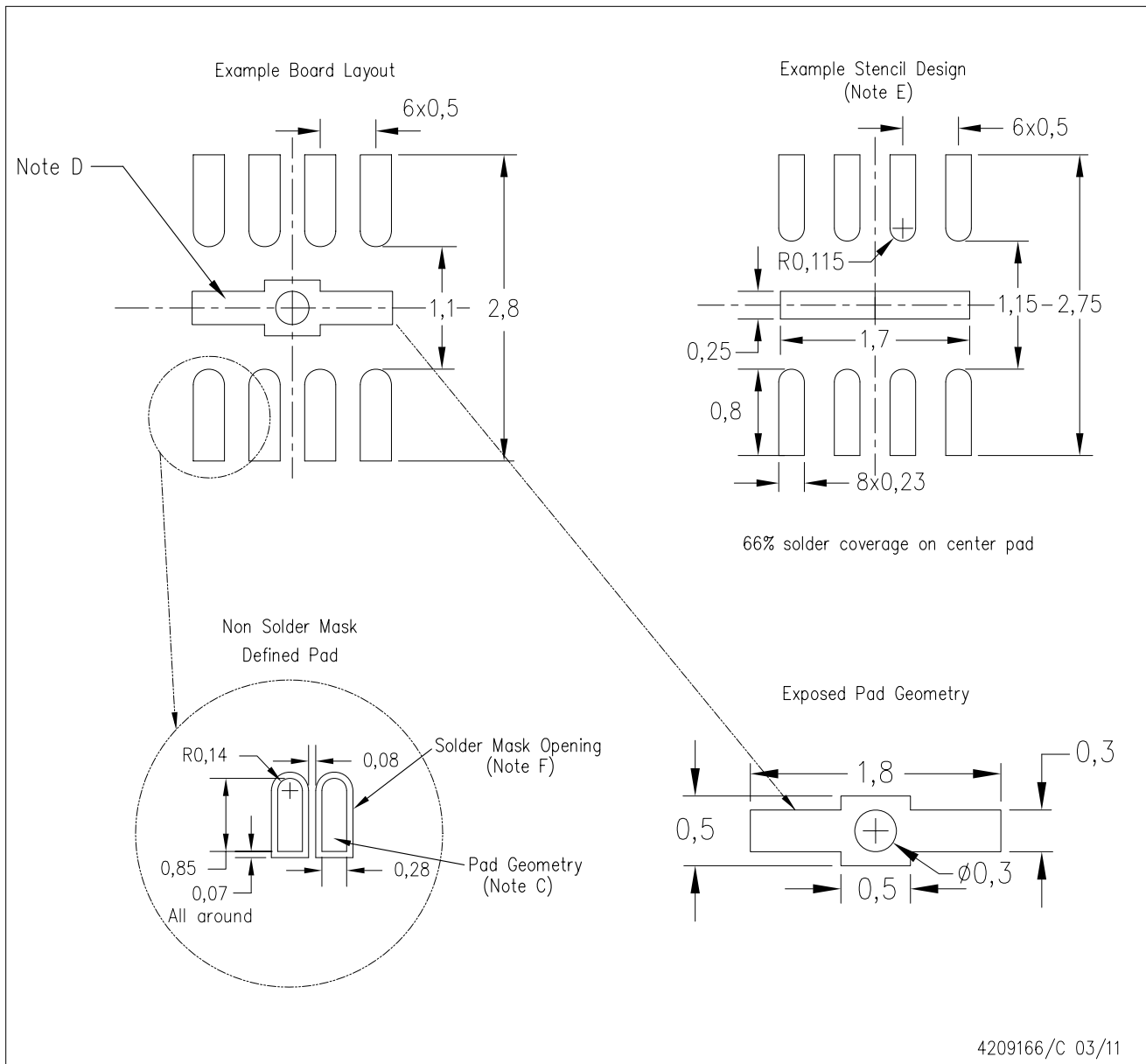

- NOTES:
- All linear dimensions are in millimeters.
  - This drawing is subject to change without notice.
  - Publication IPC-7351 is recommended for alternate designs.
  - This package is designed to be soldered to a thermal pad on the board. Refer to Application Note, Quad Flat-Pack Packages, Texas Instruments Literature No. SLUA271, and also the Product Data Sheets for specific thermal information, via requirements, and recommended board layout. These documents are available at [www.ti.com](http://www.ti.com) <<http://www.ti.com>>.
  - Laser cutting apertures with trapezoidal walls and also rounding corners will offer better paste release. Customers should contact their board assembly site for stencil design recommendations. Refer to IPC 7525 for stencil design considerations.
  - Customers should contact their board fabrication site for minimum solder mask web tolerances between signal pads.

## IMPORTANT NOTICE

Texas Instruments Incorporated and its subsidiaries (TI) reserve the right to make corrections, modifications, enhancements, improvements, and other changes to its products and services at any time and to discontinue any product or service without notice. Customers should obtain the latest relevant information before placing orders and should verify that such information is current and complete. All products are sold subject to TI's terms and conditions of sale supplied at the time of order acknowledgment.

TI warrants performance of its hardware products to the specifications applicable at the time of sale in accordance with TI's standard warranty. Testing and other quality control techniques are used to the extent TI deems necessary to support this warranty. Except where mandated by government requirements, testing of all parameters of each product is not necessarily performed.

TI assumes no liability for applications assistance or customer product design. Customers are responsible for their products and applications using TI components. To minimize the risks associated with customer products and applications, customers should provide adequate design and operating safeguards.

TI does not warrant or represent that any license, either express or implied, is granted under any TI patent right, copyright, mask work right, or other TI intellectual property right relating to any combination, machine, or process in which TI products or services are used. Information published by TI regarding third-party products or services does not constitute a license from TI to use such products or services or a warranty or endorsement thereof. Use of such information may require a license from a third party under the patents or other intellectual property of the third party, or a license from TI under the patents or other intellectual property of TI.

Reproduction of TI information in TI data books or data sheets is permissible only if reproduction is without alteration and is accompanied by all associated warranties, conditions, limitations, and notices. Reproduction of this information with alteration is an unfair and deceptive business practice. TI is not responsible or liable for such altered documentation. Information of third parties may be subject to additional restrictions.

Resale of TI products or services with statements different from or beyond the parameters stated by TI for that product or service voids all express and any implied warranties for the associated TI product or service and is an unfair and deceptive business practice. TI is not responsible or liable for any such statements.

TI products are not authorized for use in safety-critical applications (such as life support) where a failure of the TI product would reasonably be expected to cause severe personal injury or death, unless officers of the parties have executed an agreement specifically governing such use. Buyers represent that they have all necessary expertise in the safety and regulatory ramifications of their applications, and acknowledge and agree that they are solely responsible for all legal, regulatory and safety-related requirements concerning their products and any use of TI products in such safety-critical applications, notwithstanding any applications-related information or support that may be provided by TI. Further, Buyers must fully indemnify TI and its representatives against any damages arising out of the use of TI products in such safety-critical applications.

TI products are neither designed nor intended for use in military/aerospace applications or environments unless the TI products are specifically designated by TI as military-grade or "enhanced plastic." Only products designated by TI as military-grade meet military specifications. Buyers acknowledge and agree that any such use of TI products which TI has not designated as military-grade is solely at the Buyer's risk, and that they are solely responsible for compliance with all legal and regulatory requirements in connection with such use.

TI products are neither designed nor intended for use in automotive applications or environments unless the specific TI products are designated by TI as compliant with ISO/TS 16949 requirements. Buyers acknowledge and agree that, if they use any non-designated products in automotive applications, TI will not be responsible for any failure to meet such requirements.

Following are URLs where you can obtain information on other Texas Instruments products and application solutions:

### Products

Audio	<a href="http://www.ti.com/audio">www.ti.com/audio</a>
Amplifiers	<a href="http://amplifier.ti.com">amplifier.ti.com</a>
Data Converters	<a href="http://dataconverter.ti.com">dataconverter.ti.com</a>
DLP® Products	<a href="http://www.dlp.com">www.dlp.com</a>
DSP	<a href="http://dsp.ti.com">dsp.ti.com</a>
Clocks and Timers	<a href="http://www.ti.com/clocks">www.ti.com/clocks</a>
Interface	<a href="http://interface.ti.com">interface.ti.com</a>
Logic	<a href="http://logic.ti.com">logic.ti.com</a>
Power Mgmt	<a href="http://power.ti.com">power.ti.com</a>
Microcontrollers	<a href="http://microcontroller.ti.com">microcontroller.ti.com</a>
RFID	<a href="http://www.ti-rfid.com">www.ti-rfid.com</a>
RF/IF and ZigBee® Solutions	<a href="http://www.ti.com/lprf">www.ti.com/lprf</a>

### Applications

Communications and Telecom	<a href="http://www.ti.com/communications">www.ti.com/communications</a>
Computers and Peripherals	<a href="http://www.ti.com/computers">www.ti.com/computers</a>
Consumer Electronics	<a href="http://www.ti.com/consumer-apps">www.ti.com/consumer-apps</a>
Energy and Lighting	<a href="http://www.ti.com/energy">www.ti.com/energy</a>
Industrial	<a href="http://www.ti.com/industrial">www.ti.com/industrial</a>
Medical	<a href="http://www.ti.com/medical">www.ti.com/medical</a>
Security	<a href="http://www.ti.com/security">www.ti.com/security</a>
Space, Avionics and Defense	<a href="http://www.ti.com/space-avionics-defense">www.ti.com/space-avionics-defense</a>
Transportation and Automotive	<a href="http://www.ti.com/automotive">www.ti.com/automotive</a>
Video and Imaging	<a href="http://www.ti.com/video">www.ti.com/video</a>
Wireless	<a href="http://www.ti.com/wireless-apps">www.ti.com/wireless-apps</a>

TI E2E Community Home Page

[e2e.ti.com](http://e2e.ti.com)

Mailing Address: Texas Instruments, Post Office Box 655303, Dallas, Texas 75265  
Copyright © 2011, Texas Instruments Incorporated