

20-BIT FET BUS SWITCH

2.5-V/3.3-V LOW-VOLTAGE BUS SWITCH WITH 5-V-TOLERANT LEVEL SHIFTER

Check for Samples: [SN74CB3T16210](#)

FEATURES

- Member of the Texas Instruments Widebus™ Family
- Output Voltage Translation Tracks V_{CC}
- Supports Mixed-Mode Signal Operation on All Data I/O Ports
 - 5-V Input Down to 3.3-V Output Level Shift With 3.3-V V_{CC}
 - 5-V/3.3-V Input Down to 2.5-V Output Level Shift With 2.5-V V_{CC}
- 5-V-Tolerant I/Os With Device Powered Up or Powered Down
- Bidirectional Data Flow With Near-Zero Propagation Delay
- Low ON-State Resistance (r_{on}) Characteristics ($r_{on} = 5 \Omega$ Typ)
- Low Input/Output Capacitance Minimizes Loading ($C_{io(OFF)} = 5$ pF Typ)
- Data and Control Inputs Provide Undershoot Clamp Diodes
- Low Power Consumption ($I_{CC} = 40 \mu A$ Max)
- V_{CC} Operating Range From 2.3 V to 3.6 V
- Data I/Os Support 0- to 5-V Signaling Levels (0.8 V, 1.2 V, 1.5 V, 1.8 V, 2.5 V, 3.3 V, 5 V)
- Control Inputs Can Be Driven by TTL or 5-V/3.3-V CMOS Outputs
- I_{off} Supports Partial-Power-Down Mode Operation
- Latch-Up Performance Exceeds 250 mA Per JESD 17
- ESD Performance Tested Per JESD 22
 - 2000-V Human-Body Model (A114-B, Class II)
 - 1000-V Charged-Device Model (C101)

- Supports Digital Applications: Level Translation, PCI Interface, USB Interface, Memory Interleaving, and Bus Isolation
- Ideal for Low-Power Portable Equipment

DGG OR DGV PACKAGE
(TOP VIEW)

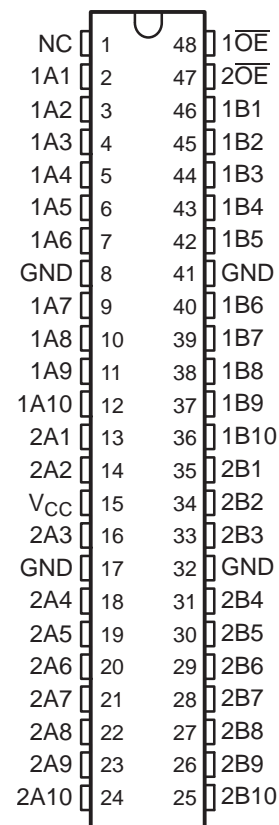

NC - No internal connection

DESCRIPTION/ORDERING INFORMATION

The SN74CB3T16210 is a high-speed TTL-compatible FET bus switch with low ON-state resistance (r_{on}), allowing for minimal propagation delay. The device fully supports mixed-mode signal operation on all data I/O ports by providing voltage translation that tracks V_{CC} . The SN74CB3T16210 supports systems using 5-V TTL, 3.3-V LVTTTL, and 2.5-V CMOS switching standards, as well as user-defined switching levels (see [Figure 1](#)).



Please be aware that an important notice concerning availability, standard warranty, and use in critical applications of Texas Instruments semiconductor products and disclaimers thereto appears at the end of this data sheet.

Widebus is a trademark of Texas Instruments.

DESCRIPTION/ORDERING INFORMATION (CONTINUED)

The SN74CB3T16210 is organized as two 10-bit bus switches with separate output-enable ($\overline{1OE}$, $\overline{2OE}$) inputs. It can be used as two 10-bit bus switches or as one 20-bit bus switch. When \overline{OE} is low, the associated 10-bit bus switch is ON, and the A port is connected to the B port, allowing bidirectional data flow between ports. When \overline{OE} is high, the associated 10-bit bus switch is OFF, and a high-impedance state exists between the A and B ports.

This device is fully specified for partial-power-down applications using I_{off} . The I_{off} feature ensures that damaging current will not backflow through the device when it is powered down. The device has isolation during power off.

To ensure the high-impedance state during power up or power down, \overline{OE} should be tied to V_{CC} through a pullup resistor; the minimum value of the resistor is determined by the current-sinking capability of the driver.

ORDERING INFORMATION

T_A	PACKAGE ⁽¹⁾		ORDERABLE PART NUMBER	TOP-SIDE MARKING
-40°C to 85°C	TSSOP – DGG	Tape and reel	SN74CB3T16210DGGR	CB3T16210
	TVSOP – DGV	Tape and reel	SN74CB3T16210DGVR	KR210

(1) Package drawings, standard packing quantities, thermal data, symbolization, and PCB design guidelines are available at www.ti.com/sc/package.

FUNCTION TABLE (EACH 10-BIT BUS SWITCH)

INPUT \overline{OE}	INPUT/OUTPUT A	FUNCTION
L	B	A port = B port
H	Z	Disconnect

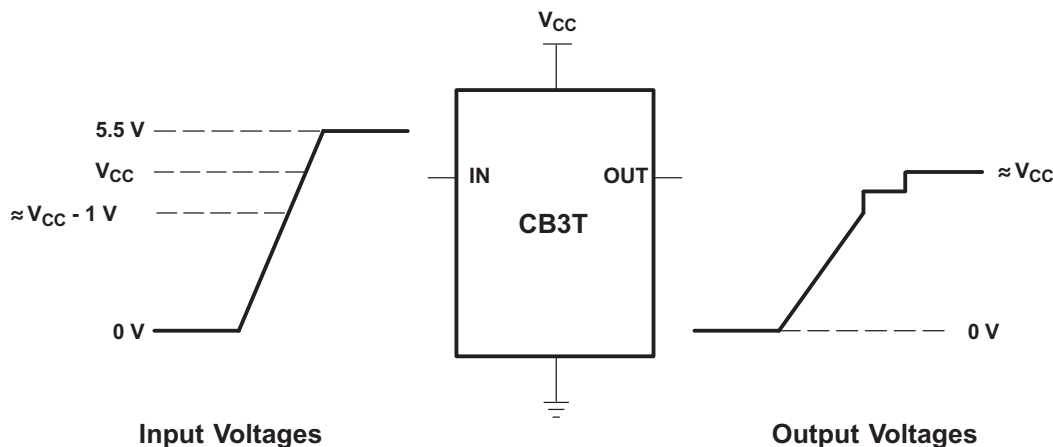

If the input high voltage (V_{IH}) level is greater than or equal to $V_{CC} + 1V$, and less than or equal to 5.5V, the output high voltage (V_{OH}) level will be equal to approximately the V_{CC} voltage level.

Figure 1. Typical DC Voltage Translation Characteristics

**GQL PACKAGE
(TOP VIEW)**

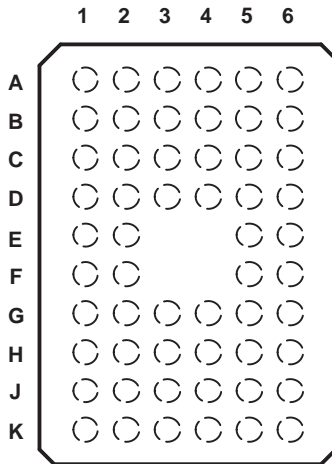

TERMINAL ASSIGNMENTS⁽¹⁾

	1	2	3	4	5	6
A	1A2	1A1	NC	$\overline{1OE}$	$\overline{2OE}$	1B1
B	1A5	1A4	1A3	1B2	1B3	1B4
C	NC	GND	1A6	1B5	1B6	NC
D	1A8	NC	1A7	NC	1B7	1B8
E	1A10	1A9			1B9	1B10
F	2A1	2A2			2B2	2B1
G	V _{CC}	GND	2A3	GND	2B4	2B3
H	NC	NC	2A4	2B5	NC	NC
J	2A5	2A6	2A7	2B7	2B6	2B5
K	2A8	2A9	2A10	2B10	2B9	2B8

(1) NC - No internal connection

LOGIC DIAGRAM (POSITIVE LOGIC)

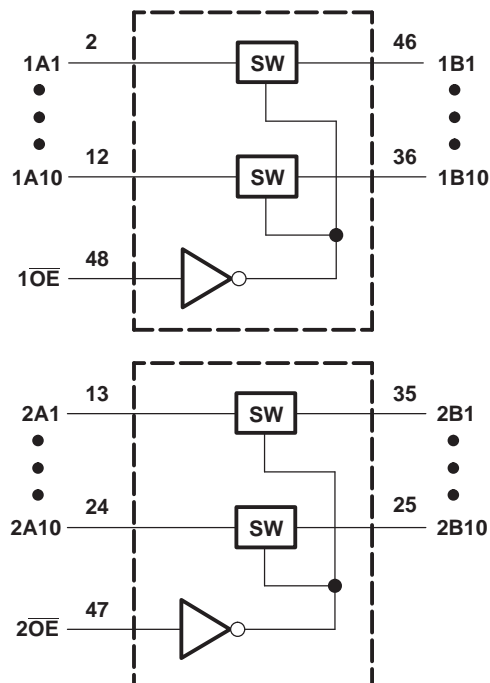

SIMPLIFIED SCHEMATIC, EACH FET SWITCH (SW)

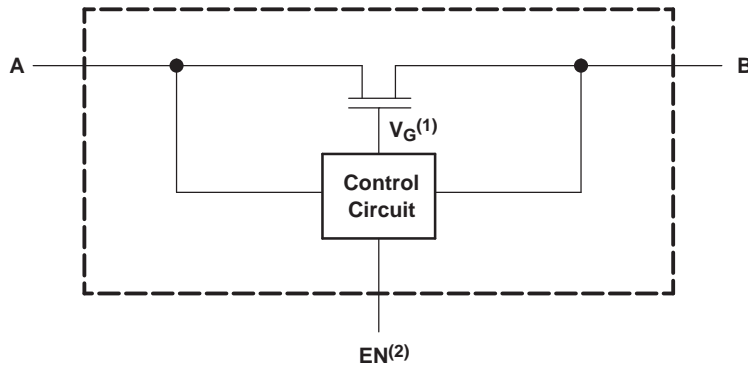

- (1) Gate voltage (V_G) is equal to approximately $V_{CC} + V_T$ when the switch is ON and $V_I > V_{CC} + V_T$.
 (2) EN is the internal enable signal applied to the switch.

Absolute Maximum Ratings⁽¹⁾

over operating free-air temperature range (unless otherwise noted)

			MIN	MAX	UNIT
V_{CC}	Supply voltage range		-0.5	7	V
V_{IN}	Control input voltage range ^{(2) (3)}		-0.5	7	V
$V_{I/O}$	Switch I/O voltage range ^{(2) (3) (4)}		-0.5	7	V
I_{IK}	Control input clamp current	$V_{IN} < 0$		-50	mA
$I_{I/OK}$	I/O port clamp current	$V_{I/O} < 0$		-50	mA
I_{IO}	ON-state switch current ⁽⁵⁾			±128	mA
	Continuous current through V_{CC} or GND			±100	mA
θ_{JA}	Package thermal impedance ⁽⁶⁾	DGG package		70	°C/W
		DGV package		58	
T_{stg}	Storage temperature range		-65	150	°C

- (1) Stresses beyond those listed under "absolute maximum ratings" may cause permanent damage to the device. These are stress ratings only, and functional operation of the device at these or any other conditions beyond those indicated under "recommended operating conditions" is not implied. Exposure to absolute-maximum-rated conditions for extended periods may affect device reliability.
 (2) All voltages are with respect to ground unless otherwise specified.
 (3) The input and output voltage ratings may be exceeded if the input and output clamp-current ratings are observed.
 (4) V_I and V_O are used to denote specific conditions for $V_{I/O}$.
 (5) I_I and I_O are used to denote specific conditions for $I_{I/O}$.
 (6) The package thermal impedance is calculated in accordance with JESD 51-7.

Recommended Operating Conditions⁽¹⁾

		MIN	MAX	UNIT	
V _{CC}	Supply voltage	2.3	3.6	V	
V _{IH}	High-level control input voltage	V _{CC} = 2.3 V to 2.7 V	1.7	5.5	V
		V _{CC} = 2.7 V to 3.6 V	2	5.5	
V _{IL}	Low-level control input voltage	V _{CC} = 2.3 V to 2.7 V	0	0.7	V
		V _{CC} = 2.7 V to 3.6 V	0	0.8	
V _{I/O}	Data input/output voltage	0	5.5	V	
T _A	Operating free-air temperature	-40	85	°C	

(1) All unused control inputs of the device must be held at V_{CC} or GND to ensure proper device operation. Refer to the TI application report, *Implications of Slow or Floating CMOS Inputs*, literature number SCBA004.

Electrical Characteristics⁽¹⁾

PARAMETER		TEST CONDITIONS	T _A = -40°C TO 85°C			UNIT	
			MIN	TYP ⁽²⁾	MAX		
V _{IK}		V _{CC} = 3 V, I _I = -18 mA			-1.2	V	
V _{OH}		See Figure 3 and Figure 4					
I _{IN}	Control inputs	V _{CC} = 3.6 V, V _{IN} = 3.6 V to 5.5 V or GND			±10	µA	
I _I		V _{CC} = 3.6 V, Switch ON, V _{IN} = V _{CC} or GND	V _I = V _{CC} - 0.7 V to 5.5 V		±20	µA	
			V _I = 0.7 V to V _{CC} - 0.7 V		-40		
			V _I = 0 to 0.7 V		±5		
I _{OZ} ⁽³⁾		V _{CC} = 3.6 V, V _O = 0 to 5.5 V, V _I = 0, Switch OFF, V _{IN} = V _{CC} or GND			±10	µA	
I _{off}		V _{CC} = 0, V _O = 0 to 5.5 V, V _I = 0,			10	µA	
I _{CC}		V _{CC} = 3.6 V, I _{I/O} = 0, Switch ON or OFF, V _{IN} = V _{CC} or GND	V _I = V _{CC} or GND		40	µA	
			V _I = 5.5 V		40		
ΔI _{CC} ⁽⁴⁾	Control inputs	V _{CC} = 3 V to 3.6 V, One input at V _{CC} - 0.6 V, Other inputs at V _{CC} or GND			300	µA	
C _{in}	Control inputs	V _{CC} = 3.3 V, V _{IN} = V _{CC} or GND			4	pF	
C _{io(OFF)}		V _{CC} = 3.3 V, V _{I/O} = 5.5 V, 3.3 V, or GND, Switch OFF, V _{IN} = V _{CC} or GND			5	pF	
C _{io(ON)}		V _{CC} = 3.3 V, Switch ON, V _{IN} = V _{CC} or GND	V _{I/O} = 5.5 V or 3.3 V		5	pF	
			V _{I/O} = GND		13		
r _{on} ⁽⁵⁾		V _{CC} = 2.3 V, TYP at V _{CC} = 2.5 V, V _I = 0	I _O = 24 mA		5	Ω	
			I _O = 16 mA		5		
		V _{CC} = 3 V, V _I = 0	I _O = 64 mA		5		8.5
			I _O = 32 mA		5		

(1) V_{IN} and I_{IN} refer to control inputs. V_I, V_O, I_I, and I_O refer to data pins.

(2) All typical values are at V_{CC} = 3.3 V (unless otherwise noted), T_A = 25°C.

(3) For I/O ports, the parameter I_{OZ} includes the input leakage current.

(4) This is the increase in supply current for each input that is at the specified TTL voltage level, rather than V_{CC} or GND.

(5) Measured by the voltage drop between A and B terminals at the indicated current through the switch. ON-state resistance is determined by the lower of the voltages of the two (A or B) terminals.

Switching Characteristics

for $V_{CC} = 2.5 \text{ V} \pm 0.2 \text{ V}$ (see [Figure 2](#))

PARAMETER	FROM (INPUT)	TO (OUTPUT)	$V_{CC} = 2.5 \text{ V} \pm 0.2 \text{ V}$		$V_{CC} = 3.3 \text{ V} \pm 0.3 \text{ V}$		UNIT
			MIN	MAX	MIN	MAX	
$t_{pd}^{(1)}$	A or B	B or A		0.15		0.25	ns
t_{en}	\overline{OE}	A or B	1	12	1	10	ns
t_{dis}	\overline{OE}	A or B	1	7.5	1	8.5	ns

- (1) The propagation delay is the calculated RC time constant of the typical ON-state resistance of the switch and the specified load capacitance, when driven by an ideal voltage source (zero output impedance).

PARAMETER MEASUREMENT INFORMATION

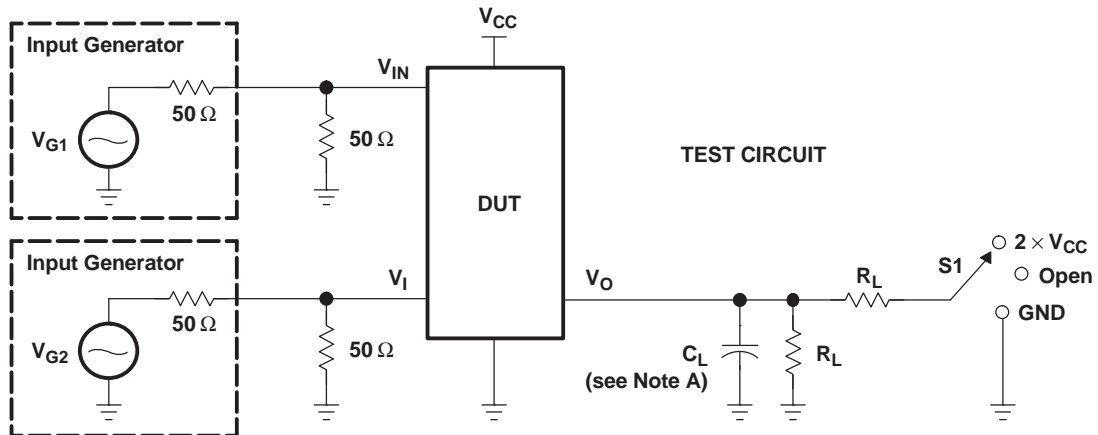

TEST	V _{CC}	S1	R _L	V _I	C _L	V _Δ
t _{pd(s)}	2.5 V ± 0.2 V	Open	500 Ω	3.6 V or GND	30 pF	
	3.3 V ± 0.3 V	Open	500 Ω	5.5 V or GND	50 pF	
t _{PLZ} /t _{PZL}	2.5 V ± 0.2 V	2 × V _{CC}	500 Ω	GND	30 pF	0.15 V
	3.3 V ± 0.3 V	2 × V _{CC}	500 Ω	GND	50 pF	0.3 V
t _{PHZ} /t _{PZH}	2.5 V ± 0.2 V	Open	500 Ω	3.6 V	30 pF	0.15 V
	3.3 V ± 0.3 V	Open	500 Ω	5.5 V	50 pF	0.3 V

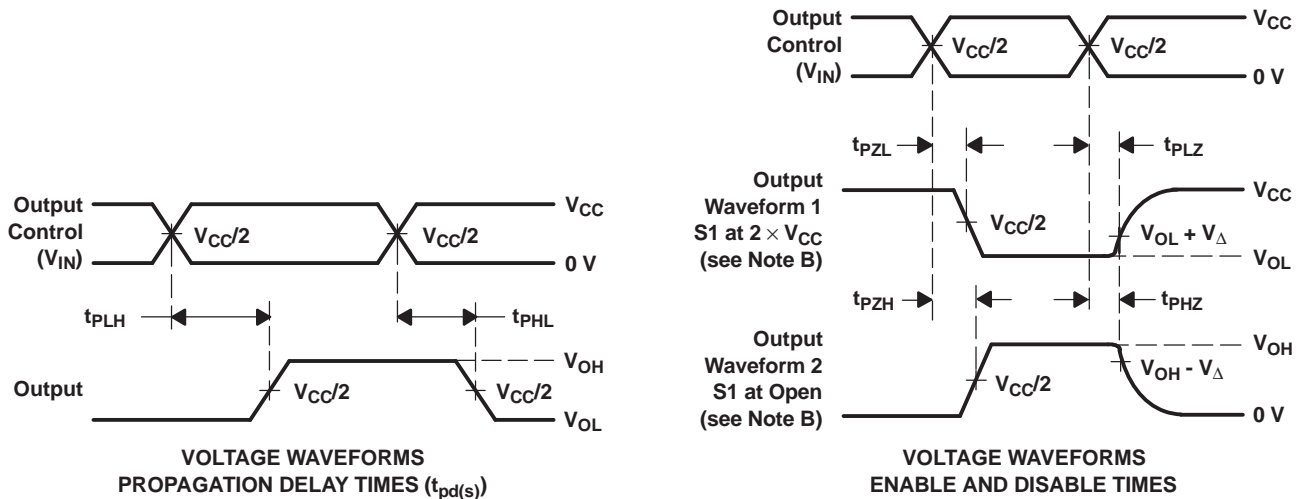

- NOTES: A. C_L includes probe and jig capacitance.
 B. Waveform 1 is for an output with internal conditions such that the output is low, except when disabled by the output control. Waveform 2 is for an output with internal conditions such that the output is high, except when disabled by the output control.
 C. All input pulses are supplied by generators having the following characteristics: PRR ≤ 10 MHz, Z_O = 50 Ω, t_r ≤ 2.5 ns, t_f ≤ 2.5 ns.
 D. The outputs are measured one at a time, with one transition per measurement.
 E. t_{PLZ} and t_{PZH} are the same as t_{dis}.
 F. t_{PZL} and t_{PZH} are the same as t_{en}.
 G. t_{PLH} and t_{PHL} are the same as t_{pd(s)}. The t_{pd} propagation delay is the calculated RC time constant of the typical ON-state resistance of the switch and the specified load capacitance, when driven by an ideal voltage source (zero output impedance).
 H. All parameters and waveforms are not applicable to all devices.

Figure 2. Test Circuit and Voltage Waveforms

TYPICAL CHARACTERISTICS

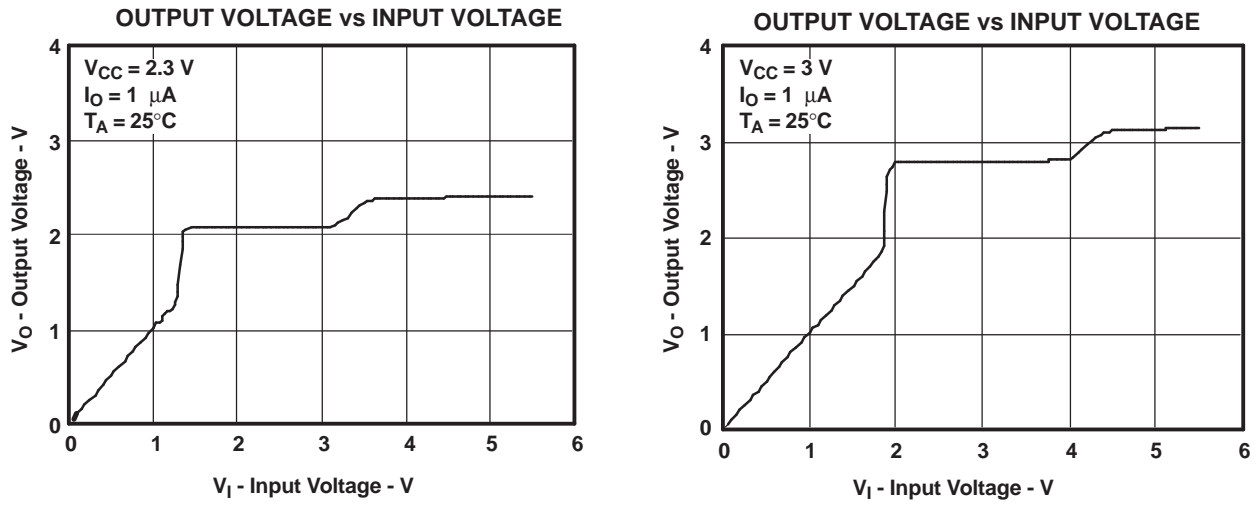

Figure 3. Data Output Voltage vs Data Input Voltage

TYPICAL CHARACTERISTICS

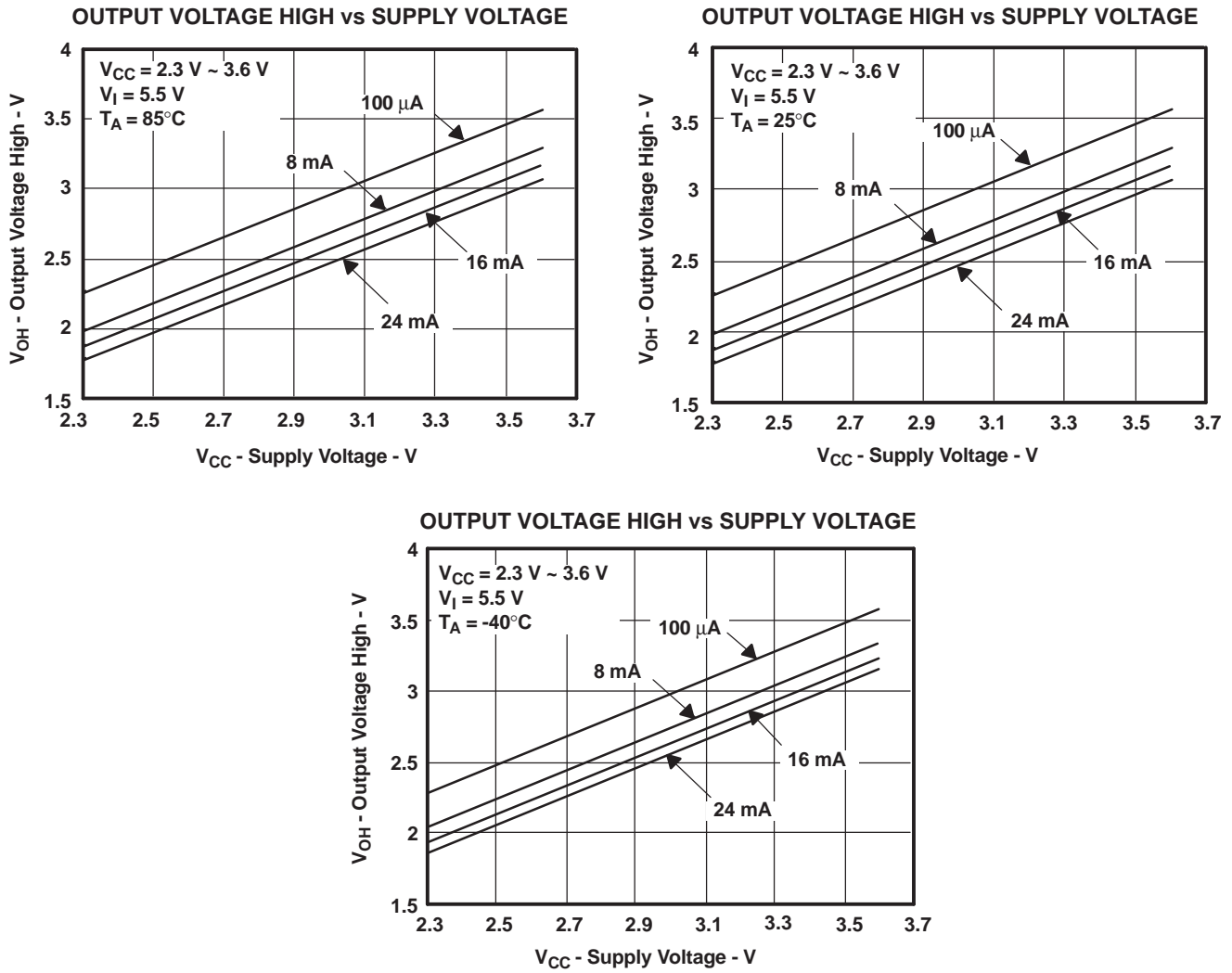

Figure 4. VOH Values

REVISION HISTORY

Changes from Revision A (March 2005) to Revision B

Page

-
- Updated graphic note and picture in figure 1. [2](#)
-

PACKAGING INFORMATION

Orderable Device	Status (1)	Package Type	Package Drawing	Pins	Package Qty	Eco Plan (2)	Lead/Ball Finish (6)	MSL Peak Temp (3)	Op Temp (°C)	Device Marking (4/5)	Samples
74CB3T16210DGGRG4	ACTIVE	TSSOP	DGG	48	2000	Green (RoHS & no Sb/Br)	CU NIPDAU	Level-1-260C-UNLIM	-40 to 85	CB3T16210	Samples
SN74CB3T16210DGG	PREVIEW	TSSOP	DGG	48	40	Green (RoHS & no Sb/Br)	CU NIPDAU	Level-1-260C-UNLIM	-40 to 85	CB3T16210	
SN74CB3T16210DGGR	ACTIVE	TSSOP	DGG	48	2000	Green (RoHS & no Sb/Br)	CU NIPDAU	Level-1-260C-UNLIM	-40 to 85	CB3T16210	Samples
SN74CB3T16210DGVR	ACTIVE	TVSOP	DGV	48	2000	Green (RoHS & no Sb/Br)	CU NIPDAU	Level-1-260C-UNLIM	-40 to 85	KR210	Samples
SN74CB3T16210DL	PREVIEW	SSOP	DL	48	25	TBD	Call TI	Call TI	-40 to 85		
SN74CB3T16210DLR	PREVIEW	SSOP	DL	48	1000	TBD	Call TI	Call TI	-40 to 85		

(1) The marketing status values are defined as follows:

ACTIVE: Product device recommended for new designs.

LIFEBUY: TI has announced that the device will be discontinued, and a lifetime-buy period is in effect.

NRND: Not recommended for new designs. Device is in production to support existing customers, but TI does not recommend using this part in a new design.

PREVIEW: Device has been announced but is not in production. Samples may or may not be available.

OBSOLETE: TI has discontinued the production of the device.

(2) Eco Plan - The planned eco-friendly classification: Pb-Free (RoHS), Pb-Free (RoHS Exempt), or Green (RoHS & no Sb/Br) - please check <http://www.ti.com/productcontent> for the latest availability information and additional product content details.

TBD: The Pb-Free/Green conversion plan has not been defined.

Pb-Free (RoHS): TI's terms "Lead-Free" or "Pb-Free" mean semiconductor products that are compatible with the current RoHS requirements for all 6 substances, including the requirement that lead not exceed 0.1% by weight in homogeneous materials. Where designed to be soldered at high temperatures, TI Pb-Free products are suitable for use in specified lead-free processes.

Pb-Free (RoHS Exempt): This component has a RoHS exemption for either 1) lead-based flip-chip solder bumps used between the die and package, or 2) lead-based die adhesive used between the die and leadframe. The component is otherwise considered Pb-Free (RoHS compatible) as defined above.

Green (RoHS & no Sb/Br): TI defines "Green" to mean Pb-Free (RoHS compatible), and free of Bromine (Br) and Antimony (Sb) based flame retardants (Br or Sb do not exceed 0.1% by weight in homogeneous material)

(3) MSL, Peak Temp. - The Moisture Sensitivity Level rating according to the JEDEC industry standard classifications, and peak solder temperature.

(4) There may be additional marking, which relates to the logo, the lot trace code information, or the environmental category on the device.

(5) Multiple Device Markings will be inside parentheses. Only one Device Marking contained in parentheses and separated by a "~" will appear on a device. If a line is indented then it is a continuation of the previous line and the two combined represent the entire Device Marking for that device.

⁽⁶⁾ Lead/Ball Finish - Orderable Devices may have multiple material finish options. Finish options are separated by a vertical ruled line. Lead/Ball Finish values may wrap to two lines if the finish value exceeds the maximum column width.

Important Information and Disclaimer:The information provided on this page represents TI's knowledge and belief as of the date that it is provided. TI bases its knowledge and belief on information provided by third parties, and makes no representation or warranty as to the accuracy of such information. Efforts are underway to better integrate information from third parties. TI has taken and continues to take reasonable steps to provide representative and accurate information but may not have conducted destructive testing or chemical analysis on incoming materials and chemicals. TI and TI suppliers consider certain information to be proprietary, and thus CAS numbers and other limited information may not be available for release.

In no event shall TI's liability arising out of such information exceed the total purchase price of the TI part(s) at issue in this document sold by TI to Customer on an annual basis.

OTHER QUALIFIED VERSIONS OF SN74CB3T16210 :

- Automotive: [SN74CB3T16210-Q1](#)

NOTE: Qualified Version Definitions:

- Automotive - Q100 devices qualified for high-reliability automotive applications targeting zero defects

TAPE AND REEL INFORMATION

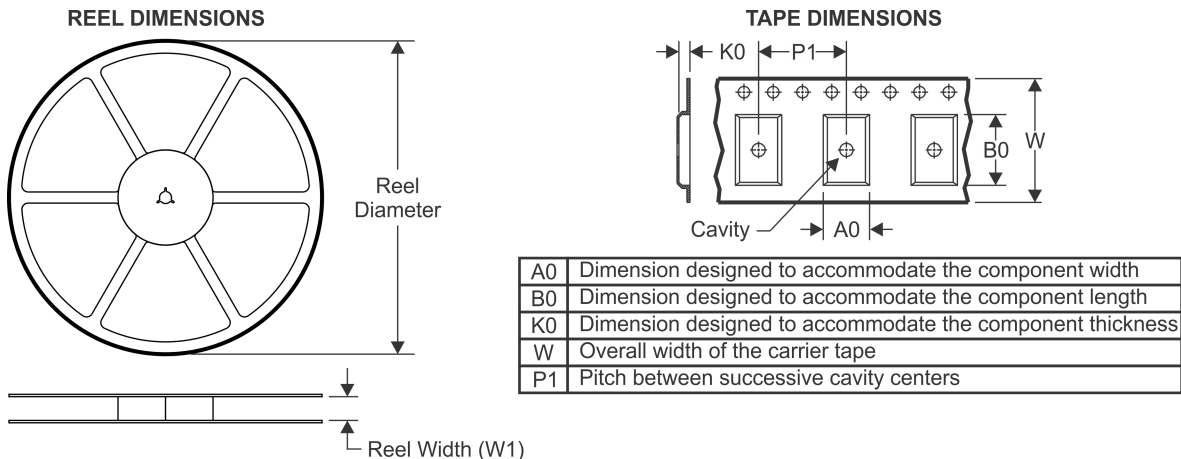

QUADRANT ASSIGNMENTS FOR PIN 1 ORIENTATION IN TAPE



*All dimensions are nominal

Device	Package Type	Package Drawing	Pins	SPQ	Reel Diameter (mm)	Reel Width W1 (mm)	A0 (mm)	B0 (mm)	K0 (mm)	P1 (mm)	W (mm)	Pin1 Quadrant
SN74CB3T16210DGGR	TSSOP	DGG	48	2000	330.0	24.4	8.6	15.8	1.8	12.0	24.0	Q1
SN74CB3T16210DGVR	TVSOP	DGV	48	2000	330.0	16.4	7.1	10.2	1.6	12.0	16.0	Q1

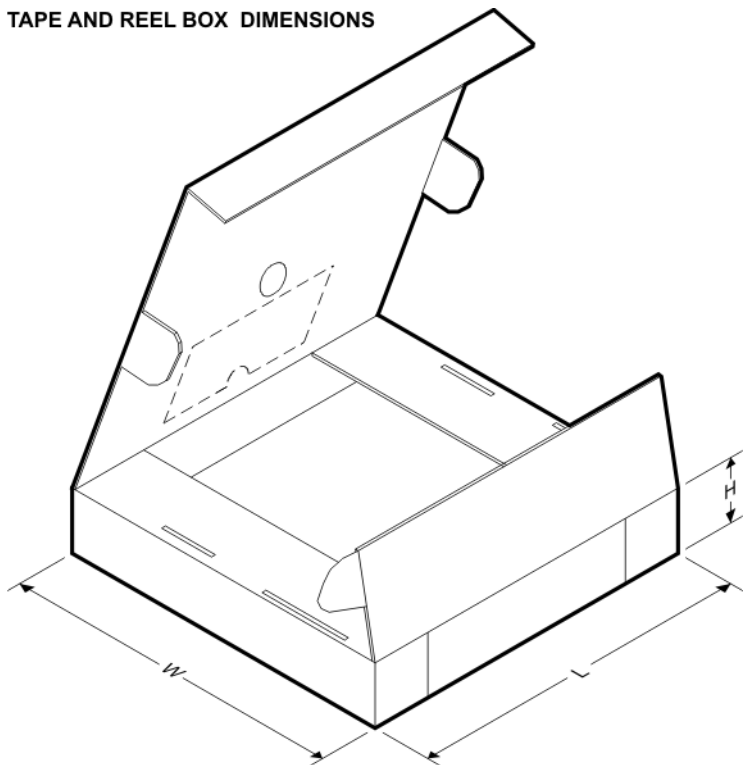
TAPE AND REEL BOX DIMENSIONS

*All dimensions are nominal

Device	Package Type	Package Drawing	Pins	SPQ	Length (mm)	Width (mm)	Height (mm)
SN74CB3T16210DGGR	TSSOP	DGG	48	2000	367.0	367.0	45.0
SN74CB3T16210DGVR	TVSOP	DGV	48	2000	367.0	367.0	38.0

DGV (R-PDSO-G**)

PLASTIC SMALL-OUTLINE

24 PINS SHOWN



4073251/E 08/00

- NOTES: A. All linear dimensions are in millimeters.
 B. This drawing is subject to change without notice.
 C. Body dimensions do not include mold flash or protrusion, not to exceed 0,15 per side.
 D. Falls within JEDEC: 24/48 Pins – MO-153
 14/16/20/56 Pins – MO-194

MECHANICAL DATA

DL (R-PDSO-G48)

PLASTIC SMALL-OUTLINE PACKAGE

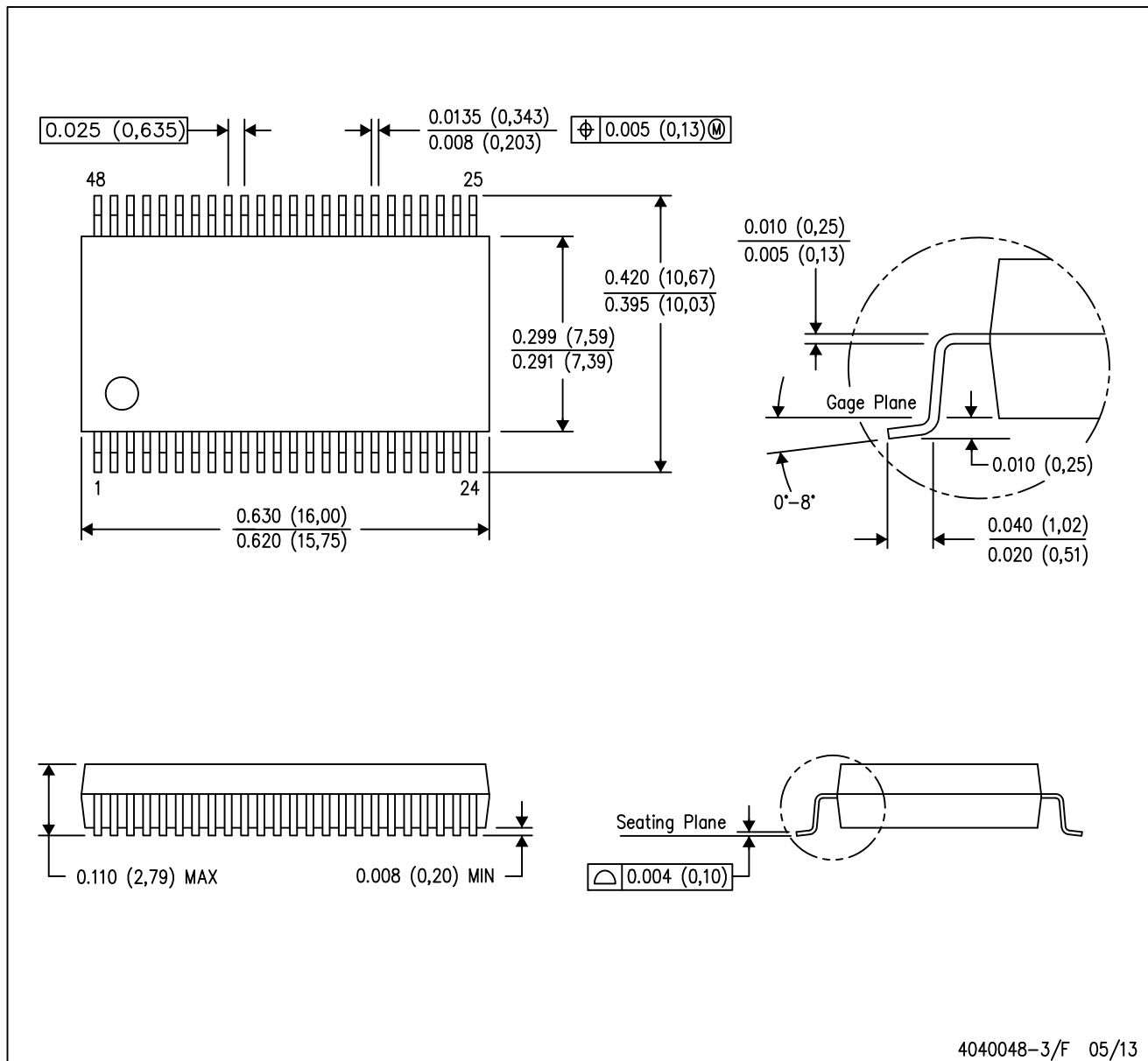

- NOTES:
- All linear dimensions are in inches (millimeters).
 - This drawing is subject to change without notice.
 - Body dimensions do not include mold flash or protrusion not to exceed 0.006 (0,15).
 - Falls within JEDEC MO-118

PowerPAD is a trademark of Texas Instruments.

DGG (R-PDSO-G**)

PLASTIC SMALL-OUTLINE PACKAGE

48 PINS SHOWN



- NOTES: A. All linear dimensions are in millimeters.
 B. This drawing is subject to change without notice.
 C. Body dimensions do not include mold protrusion not to exceed 0,15.
 D. Falls within JEDEC MO-153

IMPORTANT NOTICE

Texas Instruments Incorporated and its subsidiaries (TI) reserve the right to make corrections, enhancements, improvements and other changes to its semiconductor products and services per JESD46, latest issue, and to discontinue any product or service per JESD48, latest issue. Buyers should obtain the latest relevant information before placing orders and should verify that such information is current and complete. All semiconductor products (also referred to herein as "components") are sold subject to TI's terms and conditions of sale supplied at the time of order acknowledgment.

TI warrants performance of its components to the specifications applicable at the time of sale, in accordance with the warranty in TI's terms and conditions of sale of semiconductor products. Testing and other quality control techniques are used to the extent TI deems necessary to support this warranty. Except where mandated by applicable law, testing of all parameters of each component is not necessarily performed.

TI assumes no liability for applications assistance or the design of Buyers' products. Buyers are responsible for their products and applications using TI components. To minimize the risks associated with Buyers' products and applications, Buyers should provide adequate design and operating safeguards.

TI does not warrant or represent that any license, either express or implied, is granted under any patent right, copyright, mask work right, or other intellectual property right relating to any combination, machine, or process in which TI components or services are used. Information published by TI regarding third-party products or services does not constitute a license to use such products or services or a warranty or endorsement thereof. Use of such information may require a license from a third party under the patents or other intellectual property of the third party, or a license from TI under the patents or other intellectual property of TI.

Reproduction of significant portions of TI information in TI data books or data sheets is permissible only if reproduction is without alteration and is accompanied by all associated warranties, conditions, limitations, and notices. TI is not responsible or liable for such altered documentation. Information of third parties may be subject to additional restrictions.

Resale of TI components or services with statements different from or beyond the parameters stated by TI for that component or service voids all express and any implied warranties for the associated TI component or service and is an unfair and deceptive business practice. TI is not responsible or liable for any such statements.

Buyer acknowledges and agrees that it is solely responsible for compliance with all legal, regulatory and safety-related requirements concerning its products, and any use of TI components in its applications, notwithstanding any applications-related information or support that may be provided by TI. Buyer represents and agrees that it has all the necessary expertise to create and implement safeguards which anticipate dangerous consequences of failures, monitor failures and their consequences, lessen the likelihood of failures that might cause harm and take appropriate remedial actions. Buyer will fully indemnify TI and its representatives against any damages arising out of the use of any TI components in safety-critical applications.

In some cases, TI components may be promoted specifically to facilitate safety-related applications. With such components, TI's goal is to help enable customers to design and create their own end-product solutions that meet applicable functional safety standards and requirements. Nonetheless, such components are subject to these terms.

No TI components are authorized for use in FDA Class III (or similar life-critical medical equipment) unless authorized officers of the parties have executed a special agreement specifically governing such use.

Only those TI components which TI has specifically designated as military grade or "enhanced plastic" are designed and intended for use in military/aerospace applications or environments. Buyer acknowledges and agrees that any military or aerospace use of TI components which have **not** been so designated is solely at the Buyer's risk, and that Buyer is solely responsible for compliance with all legal and regulatory requirements in connection with such use.

TI has specifically designated certain components as meeting ISO/TS16949 requirements, mainly for automotive use. In any case of use of non-designated products, TI will not be responsible for any failure to meet ISO/TS16949.

Products

Audio	www.ti.com/audio
Amplifiers	amplifier.ti.com
Data Converters	dataconverter.ti.com
DLP® Products	www.dlp.com
DSP	dsp.ti.com
Clocks and Timers	www.ti.com/clocks
Interface	interface.ti.com
Logic	logic.ti.com
Power Mgmt	power.ti.com
Microcontrollers	microcontroller.ti.com
RFID	www.ti-rfid.com
OMAP Applications Processors	www.ti.com/omap
Wireless Connectivity	www.ti.com/wirelessconnectivity

Applications

Automotive and Transportation	www.ti.com/automotive
Communications and Telecom	www.ti.com/communications
Computers and Peripherals	www.ti.com/computers
Consumer Electronics	www.ti.com/consumer-apps
Energy and Lighting	www.ti.com/energy
Industrial	www.ti.com/industrial
Medical	www.ti.com/medical
Security	www.ti.com/security
Space, Avionics and Defense	www.ti.com/space-avionics-defense
Video and Imaging	www.ti.com/video

TI E2E Community

e2e.ti.com