

SN65LBC180-Q1

LOW-POWER DIFFERENTIAL LINE DRIVER AND RECEIVER PAIR

SGLS251A – JULY 2004 – REVISED JUNE 2008

- **Qualified for Automotive Applications**
- **Designed for High-Speed Multipoint Data Transmission Over Long Cables**
- **Operate With Pulse Durations as Low as 30 ns**
- **Low Supply Current . . . 5 mA Max**
- **Meet or Exceed the Requirements of ANSI Standard RS-485 and ISO 8482:1987(E)**
- **3-State Outputs for Party-Line Buses**
- **Common-Mode Voltage Range of -7 V to 12 V**
- **Thermal Shutdown Protection Prevents Driver Damage From Bus Contention**
- **Positive and Negative Output Current Limiting**
- **Pin Compatible With the SN75ALS180**

description

The SN65LBC180 differential driver and receiver pair is a monolithic integrated circuit designed for bidirectional data communication over long cables that take on the characteristics of transmission lines. It is a balanced, or differential, voltage mode device that meets or exceeds the requirements of industry standards ANSI RS-485 and ISO 8482:1987(E). The device is designed using TI's proprietary LinBiCMOS™ with the low power consumption of CMOS and the precision and robustness of bipolar transistors in the same circuit.

The SN65LBC180 combines a differential line driver and receiver with 3-state outputs and operates from a single 5-V supply. The driver and receiver have active-high and active-low enables, respectively, which can be externally connected to function as a direction control. The driver differential outputs and the receiver differential inputs are connected to separate terminals for full-duplex operation and are designed to present minimum loading to the bus whether disabled or powered off ($V_{CC} = 0$). This part features a wide common-mode voltage range making it suitable for point-to-point or multipoint data-bus applications.

**D PACKAGE
(TOP VIEW)**

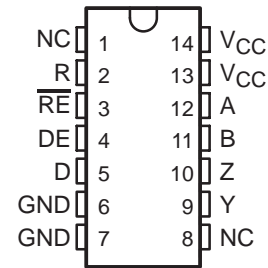

NC – No internal connection

Function Tables

DRIVER

INPUT D	ENABLE DE	OUTPUTS	
		Y	Z
H	H	H	L
L	H	L	H
X	L	Z	Z

RECEIVER

DIFFERENTIAL INPUTS A – B	ENABLE \overline{RE}	OUTPUT R
$V_{ID} \geq 0.2 V$	L	H
$-0.2 V < V_{ID} < 0.2 V$	L	?
$V_{ID} \leq -0.2 V$	L	L
X	H	Z
Open circuit	L	H

H = high level, L = low level, ? = indeterminate, X = irrelevant, Z = high impedance (off)

logic diagram (positive logic)

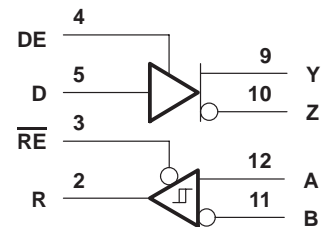

Please be aware that an important notice concerning availability, standard warranty, and use in critical applications of Texas Instruments semiconductor products and disclaimers thereto appears at the end of this data sheet.

LinBiCMOS is a trademark of Texas Instruments Incorporated.

PRODUCTION DATA information is current as of publication date. Products conform to specifications per the terms of Texas Instruments standard warranty. Production processing does not necessarily include testing of all parameters.



POST OFFICE BOX 655303 • DALLAS, TEXAS 75265

Copyright © 2008 Texas Instruments Incorporated

SN65LBC180-Q1

LOW-POWER DIFFERENTIAL LINE DRIVER AND RECEIVER PAIR

SGLS251A – JULY 2004 – REVISED JUNE 2008

description/ordering information (continued)

ORDERING INFORMATION†

TA	PACKAGE‡		ORDERABLE PART NUMBER	TOP-SIDE MARKING
-40°C to 85°C	SOIC – D	Tape and reel	SN65LBC180IDRQ1	LBC180Q1

† For the most current package and ordering information, see the Package Option Addendum at the end of this document, or see the TI web site at <http://www.ti.com>.

‡ Package drawings, thermal data, and symbolization are available at <http://www.ti.com/packaging>.

The devices also provide positive and negative output-current limiting and thermal shutdown for protection from line fault conditions. The line driver shuts down at a junction temperature of approximately 172°C.



POST OFFICE BOX 655303 • DALLAS, TEXAS 75265

SN65LBC180-Q1

LOW-POWER DIFFERENTIAL LINE DRIVER AND RECEIVER PAIR

SGLS251A – JULY 2004 – REVISED JUNE 2008

schematics of inputs and outputs

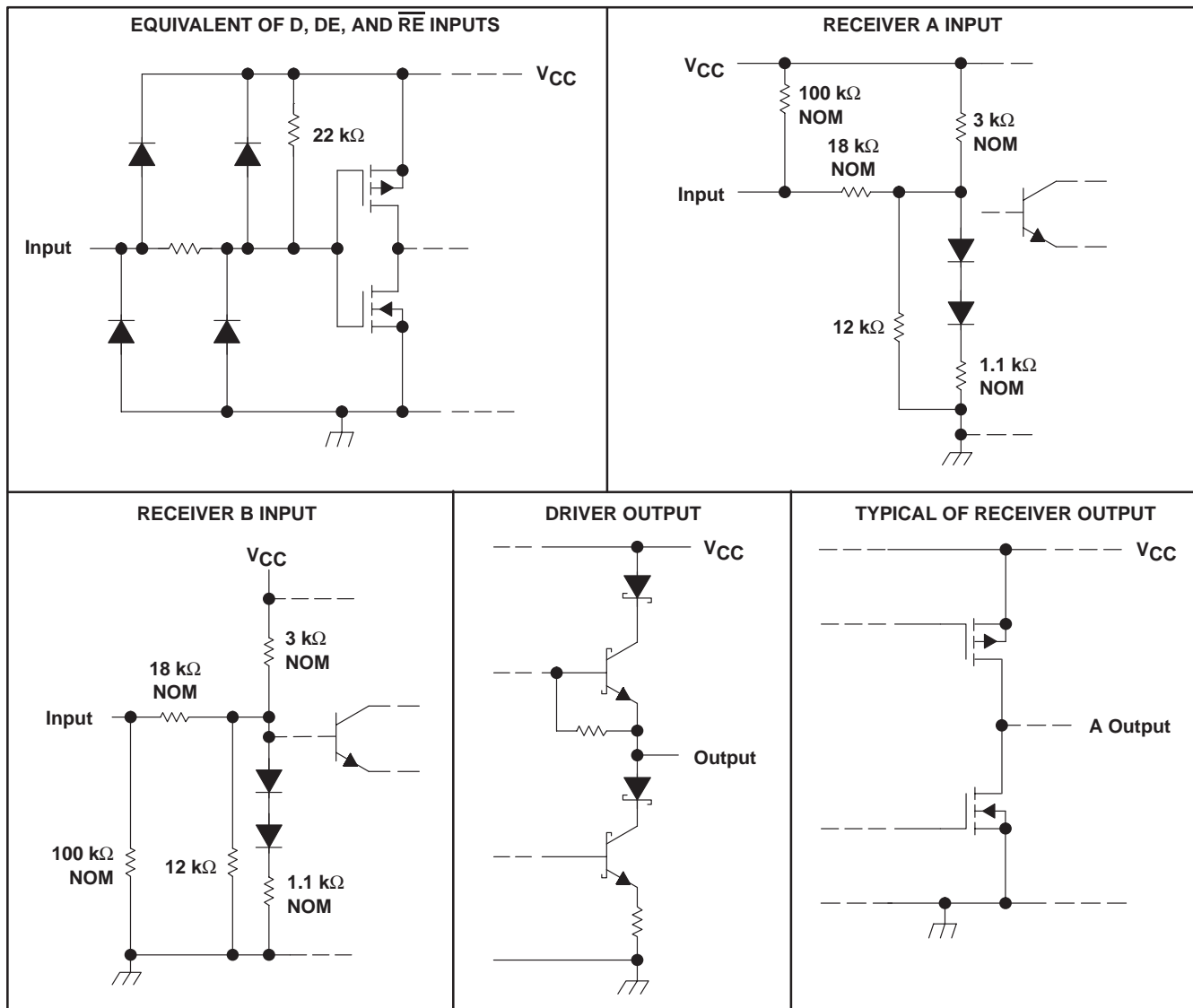

SN65LBC180-Q1

LOW-POWER DIFFERENTIAL LINE DRIVER AND RECEIVER PAIR

SGLS251A – JULY 2004 – REVISED JUNE 2008

absolute maximum ratings over operating free-air temperature range (unless otherwise noted)†

Supply voltage range, V_{CC} (see Note 1)	–0.3 V to 7 V
Input voltage range, V_I (A, B)(see Note 1)	–10 V to 15 V
Voltage range at D, R, DE, \overline{RE} (see Note 1)	–0.3 V to $V_{CC} + 0.5$ V
Continuous total power dissipation (see Note 2)	Internally limited
Total power dissipation	See Dissipation Rating Table
Operating free-air temperature range, T_A	–40°C to 85°C
Storage temperature range, T_{stg}	–65°C to 150°C
Lead temperature 1,6 mm (1/16 inch) from case for 10 seconds	260°C

† Stresses beyond those listed under “absolute maximum ratings” may cause permanent damage to the device. These are stress ratings only, and functional operation of the device at these or any other conditions beyond those indicated under “recommended operating conditions” is not implied. Exposure to absolute-maximum-rated conditions for extended periods may affect device reliability.

- NOTES: 1. All voltage values are with respect to GND.
 2. The maximum operating junction temperature is internally limited. Use the dissipation rating table to operate below this temperature.

DISSIPATION RATING TABLE

PACKAGE	$T_A \leq 25^\circ\text{C}$ POWER RATING	DERATING FACTOR ABOVE $T_A = 25^\circ\text{C}$	$T_A = 70^\circ\text{C}$ POWER RATING	$T_A = 85^\circ\text{C}$ POWER RATING
D	950 mW	7.6 mW/°C	608 mW	494 mW

recommended operating conditions

		MIN	NOM	MAX	UNIT
Supply voltage, V_{CC}		4.75	5	5.25	V
High-level input voltage, V_{IH}	D, DE, and \overline{RE}	2			V
Low-level input voltage, V_{IL}	D, DE, and \overline{RE}			0.8	V
Differential input voltage, V_{ID}		–6‡		6	V
Voltage at any bus terminal (separately or common mode), V_O , V_I , or V_{IC}	A, B, Y, or Z	–7‡		12	V
High-level output current, I_{OH}	Y or Z			–60	mA
	R			–8	
Low-level output current, I_{OL}	Y or Z			60	mA
	R			8	
Operating free-air temperature, T_A		–40		85	°C

‡ The algebraic convention where the least positive (more negative) limit is designated minimum, is used in this data sheet for the differential input voltage, voltage at any bus terminal, operating temperature, input threshold voltage, and common-mode output voltage.



SN65LBC180-Q1

LOW-POWER DIFFERENTIAL LINE DRIVER AND RECEIVER PAIR

SGLS251A – JULY 2004 – REVISED JUNE 2008

DRIVER SECTION

electrical characteristics over recommended operating conditions (unless otherwise noted)

PARAMETER		TEST CONDITIONS		MIN	TYP†	MAX	UNIT
V_{IK}	Input clamp voltage	$I_I = -18 \text{ mA}$				-1.5	V
$ V_{OD} $	Differential output voltage magnitude (see Note 3)	$R_L = 54 \Omega$,	See Figure 1	1.1	2.5	5	V
		$R_L = 60 \Omega$,	See Figure 2	1.1	2	5	
$\Delta V_{OD} $	Change in magnitude of differential output voltage (see Note 4)	See Figures 1 and 2				± 0.2	V
V_{OC}	Common-mode output voltage			1	2.5	3	V
$\Delta V_{OC} $	Change in magnitude of common-mode output voltage (see Note 4)	$R_L = 54 \Omega$,	See Figure 1			± 0.2	V
I_O	Output current with power off	$V_{CC} = 0$,	$V_O = -7 \text{ V to } 12 \text{ V}$			± 100	μA
I_{OZ}	High-impedance-state output current	$V_O = -7 \text{ V to } 12 \text{ V}$				± 100	μA
I_{IH}	High-level input current	$V_I = 2.4 \text{ V}$				-100	μA
I_{IL}	Low-level input current	$V_I = 0.4 \text{ V}$				-100	μA
I_{OS}	Short-circuit output current	$-7 \text{ V} \leq V_O \leq 12 \text{ V}$				± 250	mA
I_{CC}	Supply current	Receiver disabled	Outputs enabled			5	mA
			Outputs disabled			3	

† All typical values are at $V_{CC} = 5 \text{ V}$ and $T_A = 25^\circ\text{C}$.

- NOTES: 3. The minimum V_{OD} specification of the SN65LBC180 may not fully comply with ANSI RS-485 at operating temperatures below 0°C . System designers should take the possibly lower output signal into account in determining the maximum signal-transmission distance.
4. $\Delta|V_{OD}|$ and $\Delta|V_{OC}|$ are the changes in the steady-state magnitude of V_{OD} and V_{OC} , respectively, that occur when the input is changed from a high level to a low level.

switching characteristics, $V_{CC} = 5 \text{ V}$, $T_A = 25^\circ\text{C}$

PARAMETER		TEST CONDITIONS		MIN	TYP	MAX	UNIT
$t_{d(OD)}$	Differential output delay time	$R_L = 54 \Omega$,	See Figure 3	7	12	18	ns
$t_{t(OD)}$	Differential output transition time			5	10	20	ns
t_{PZH}	Output enable time to high level	$R_L = 110 \Omega$,	See Figure 4			35	ns
t_{PZL}	Output enable time to low level	$R_L = 110 \Omega$,	See Figure 5			35	ns
t_{PHZ}	Output disable time from high level	$R_L = 110 \Omega$,	See Figure 4			50	ns
t_{PLZ}	Output disable time from low level	$R_L = 110 \Omega$,	See Figure 5			35	ns

SN65LBC180-Q1

LOW-POWER DIFFERENTIAL LINE DRIVER AND RECEIVER PAIR

SGLS251A – JULY 2004 – REVISED JUNE 2008

RECEIVER SECTION

electrical characteristics over recommended operating conditions (unless otherwise noted)

PARAMETER		TEST CONDITIONS		MIN	TYP	MAX	UNIT
V_{IT+}	Positive-going input threshold voltage	$I_O = -8$ mA				0.2	V
V_{IT-}	Negative-going input threshold voltage	$I_O = 8$ mA		-0.2			V
V_{hys}	Hysteresis voltage ($V_{IT+} - V_{IT-}$)				45		mV
V_{IK}	Enable-input clamp voltage	$I_I = -18$ mA				-1.5	V
V_{OH}	High-level output voltage	$V_{ID} = 200$ mV,	$I_{OH} = -8$ mA	3.5	4.5		V
V_{OL}	Low-level output voltage	$V_{ID} = -200$ mV,	$I_{OL} = 8$ mA		0.3	0.5	V
I_{OZ}	High-impedance-state output current	$V_O = 0$ V to V_{CC}				± 20	μ A
I_{IH}	High-level enable-input current	$V_{IH} = 2.4$ V				-50	μ A
I_{IL}	Low-level enable-input current	$V_{IL} = 0.4$ V				-100	μ A
I_I	Bus input current	$V_I = 12$ V,	$V_{CC} = 5$ V,	0.7	1		mA
		Other input at 0 V					
		$V_I = 12$ V,	$V_{CC} = 0$ V,	0.8	1		
		Other input at 0 V					
$V_I = -7$ V,	$V_{CC} = 5$ V,	-0.5	-0.8				
Other input at 0 V							
I_{CC}	Supply current	Driver disabled	Outputs enabled			5	mA
			Outputs disabled			3	

switching characteristics, $V_{CC} = 5$ V, $T_A = 25^\circ\text{C}$

PARAMETER		TEST CONDITIONS		MIN	TYP	MAX	UNIT
t_{PHL}	Propagation delay time, high- to low-level output	$V_{ID} = -1.5$ V to 1.5 V,	See Figure 6	11	22	33	ns
t_{PLH}	Propagation delay time, low- to high-level output			11	22	33	ns
$t_{sk(p)}$	Pulse skew ($ t_{PHL} - t_{PLH} $)				3	6	ns
t_t	Transition time				5	8	ns
t_{PZH}	Output enable time to high level	See Figure 7				35	ns
t_{PZL}	Output enable time to low level					30	ns
t_{PHZ}	Output disable time from high level					35	ns
t_{PLZ}	Output disable time from low level					30	ns



PARAMETER MEASUREMENT INFORMATION

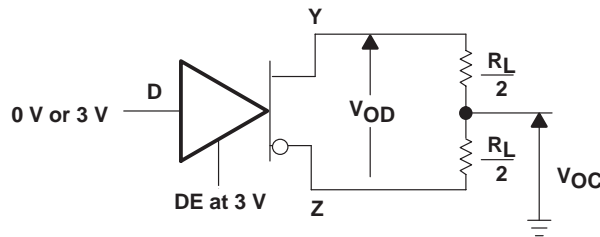

Figure 1. Differential and Common-Mode Output Voltages

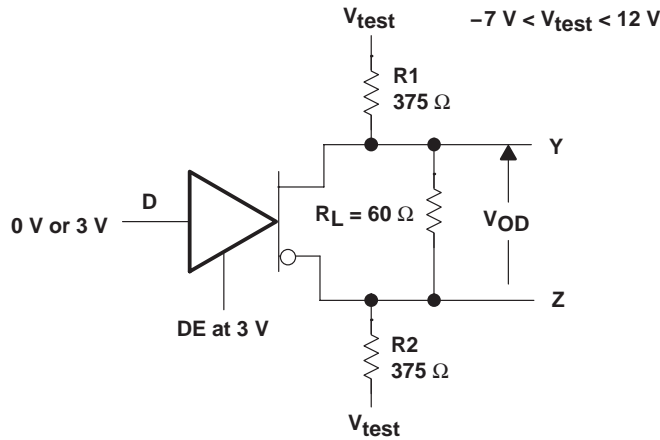
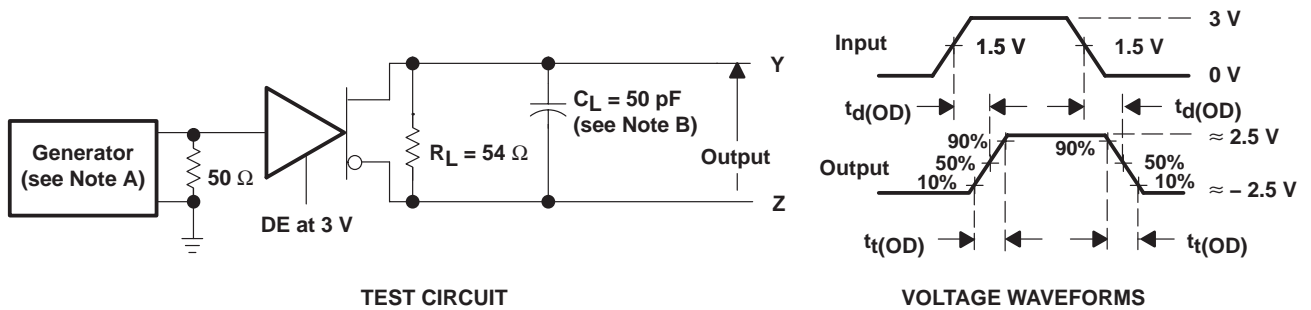

Figure 2. Driver V_{OD} Test Circuit



- NOTES: A. The input pulse is supplied by a generator having the following characteristics: PRR > 1 MHz, 50% duty cycle, $t_r \leq 6$ ns, $t_f \leq 6$ ns, $Z_O = 50 \Omega$.
 B. C_L includes probe and jig capacitance.

Figure 3. Driver Test Circuit and Differential Output Delay and Transition Time Voltage Waveforms

SN65LBC180-Q1

LOW-POWER DIFFERENTIAL LINE DRIVER AND RECEIVER PAIR

SGLS251A – JULY 2004 – REVISED JUNE 2008

PARAMETER MEASUREMENT INFORMATION

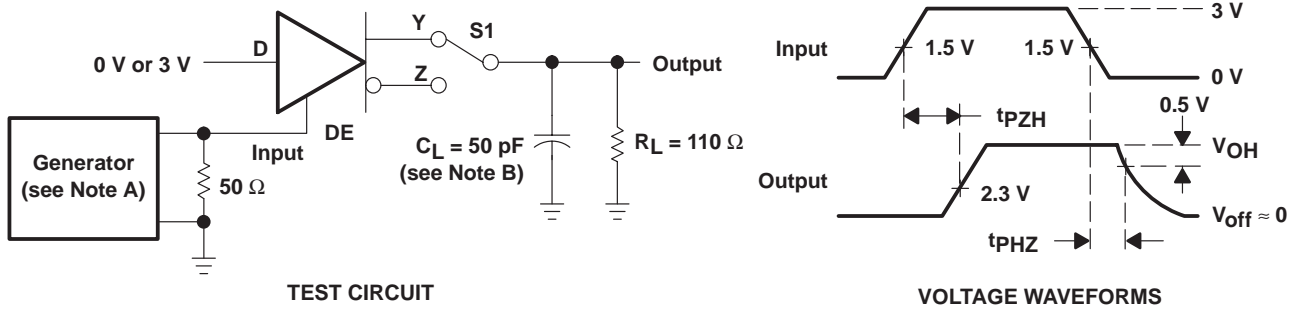

Figure 4. Driver Test Circuit and Enable and Disable Time Waveforms

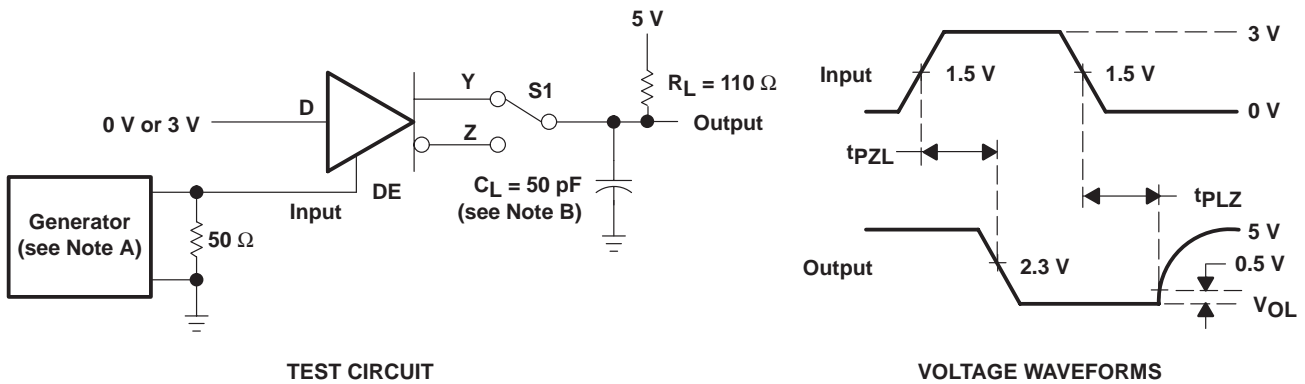
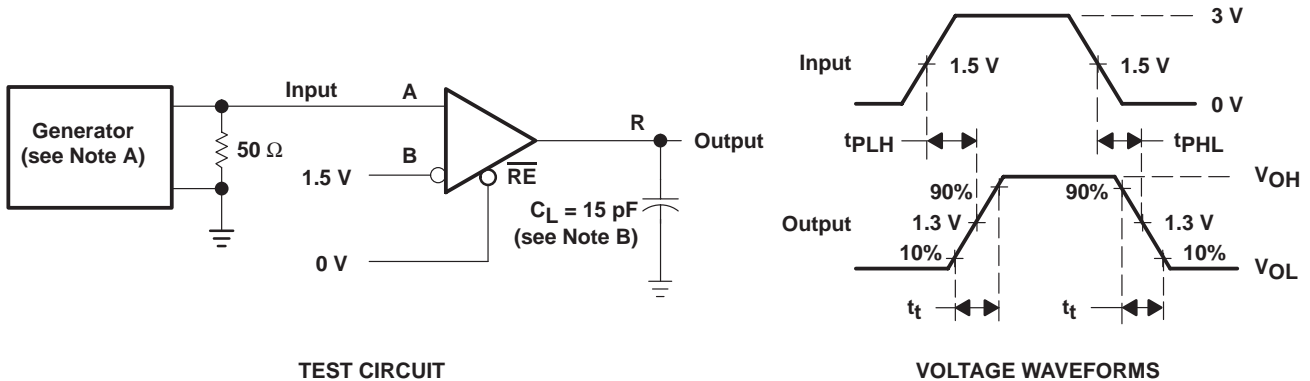

Figure 5. Driver Test Circuit and Enable and Disable Time Voltage Waveforms



- NOTES: A. The input pulse is supplied by a generator having the following characteristics: $PRR \leq 1$ MHz, 50% duty cycle, $t_r \leq 6$ ns, $t_f \leq 6$ ns, $Z_0 = 50 \Omega$.
 B. C_L includes probe and jig capacitance.

Figure 6. Receiver Test Circuit and Propagation Delay Time Voltage Waveforms

SN65LBC180-Q1

LOW-POWER DIFFERENTIAL LINE DRIVER AND RECEIVER PAIR

SGLS251A – JULY 2004 – REVISED JUNE 2008

PARAMETER MEASUREMENT INFORMATION

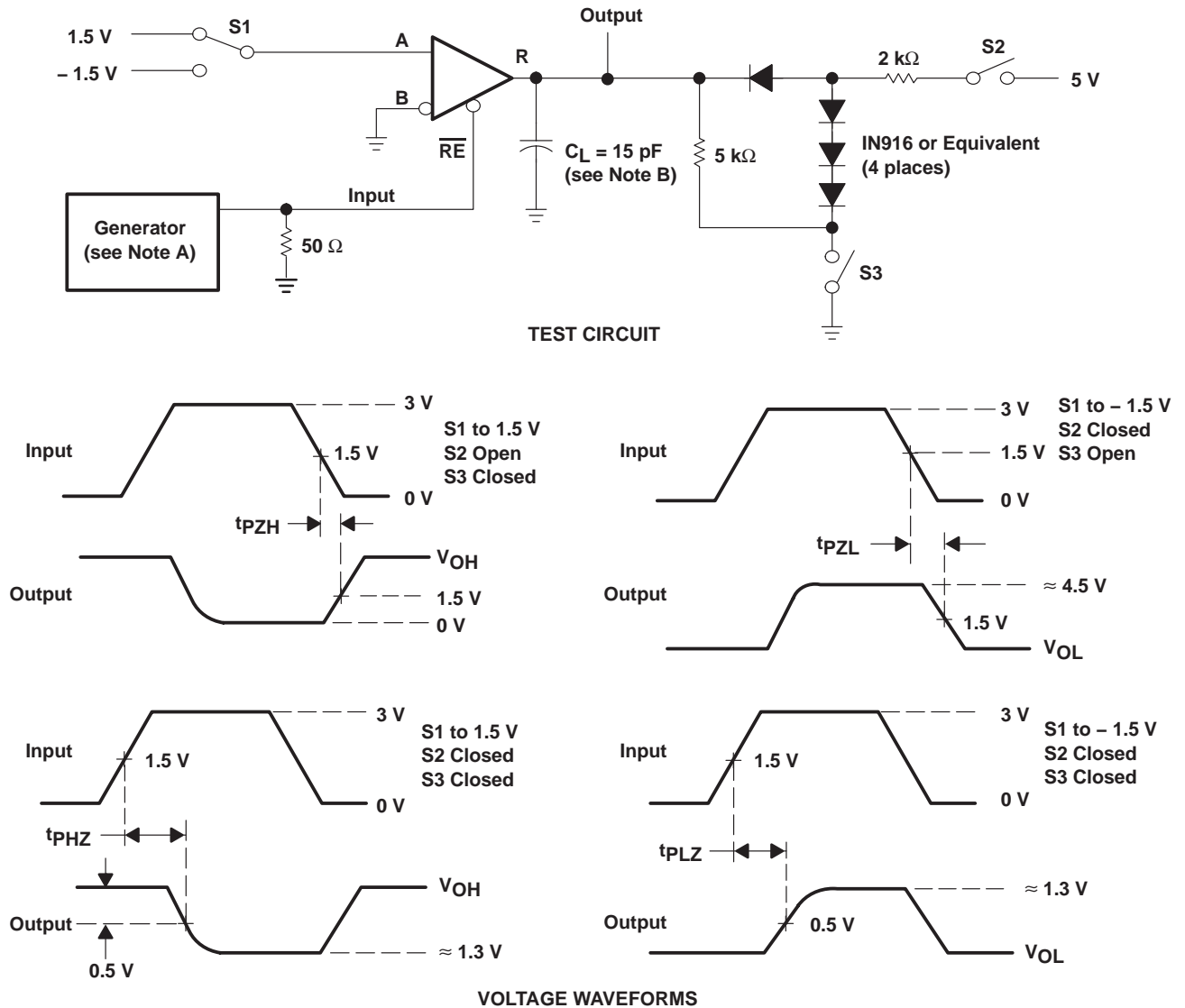

- NOTES: A. The input pulse is supplied by a generator having the following characteristics: $PRR \leq 1$ MHz, 50% duty cycle, $t_r \leq 6$ ns, $t_f \leq 6$ ns, $Z_O = 50 \Omega$.
 B. C_L includes probe and jig capacitance.

Figure 7. Receiver Output Enable and Disable Times

SN65LBC180-Q1

LOW-POWER DIFFERENTIAL LINE DRIVER AND RECEIVER PAIR

SGLS251A – JULY 2004 – REVISED JUNE 2008

TYPICAL CHARACTERISTICS

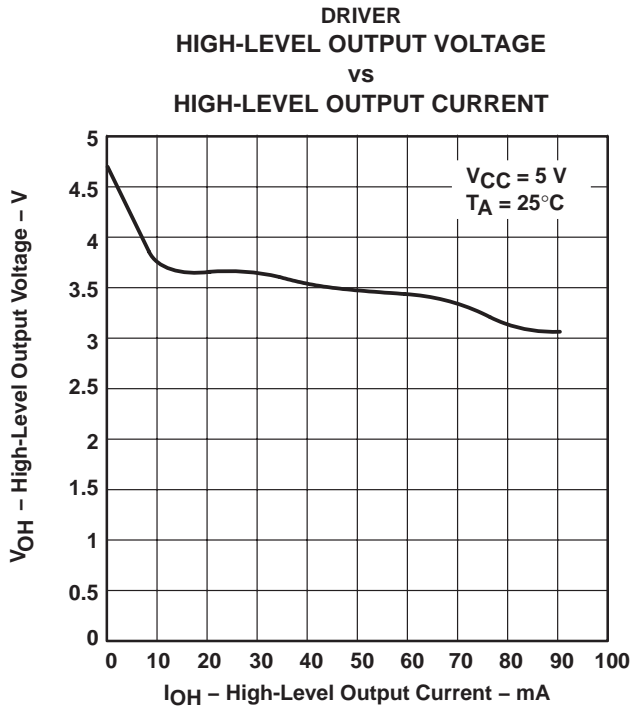

Figure 8

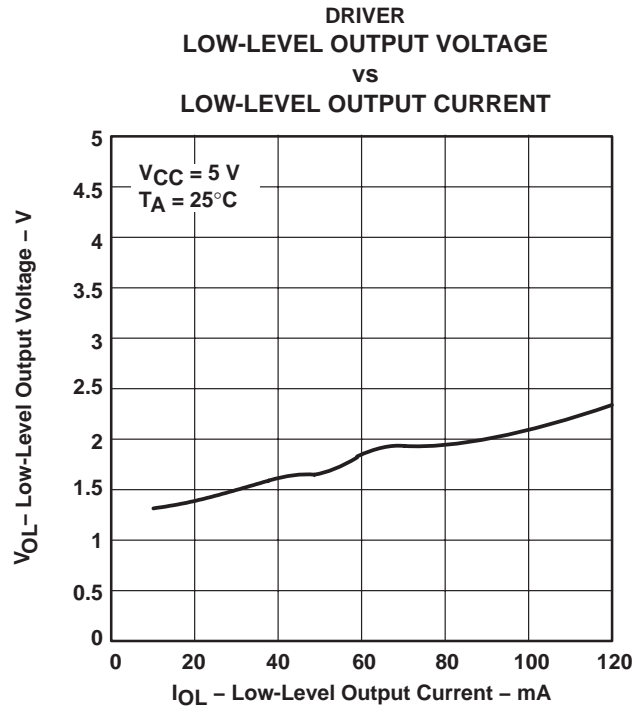

Figure 9

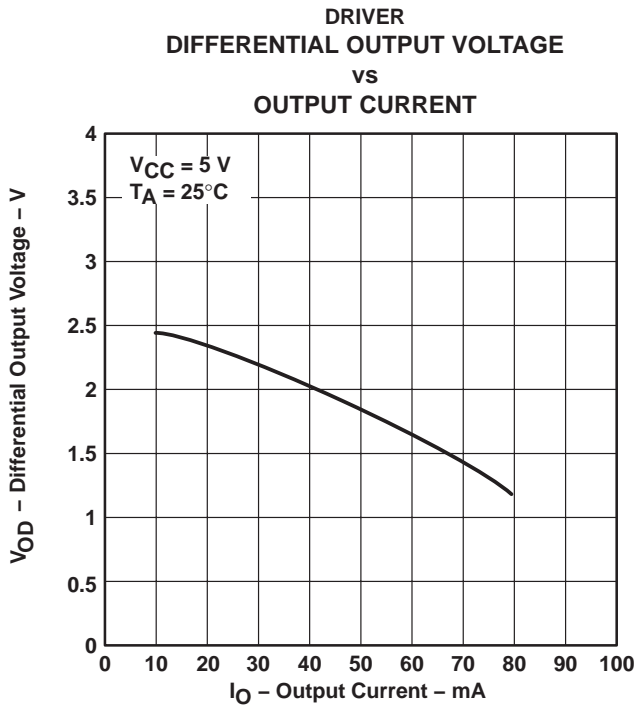

Figure 10

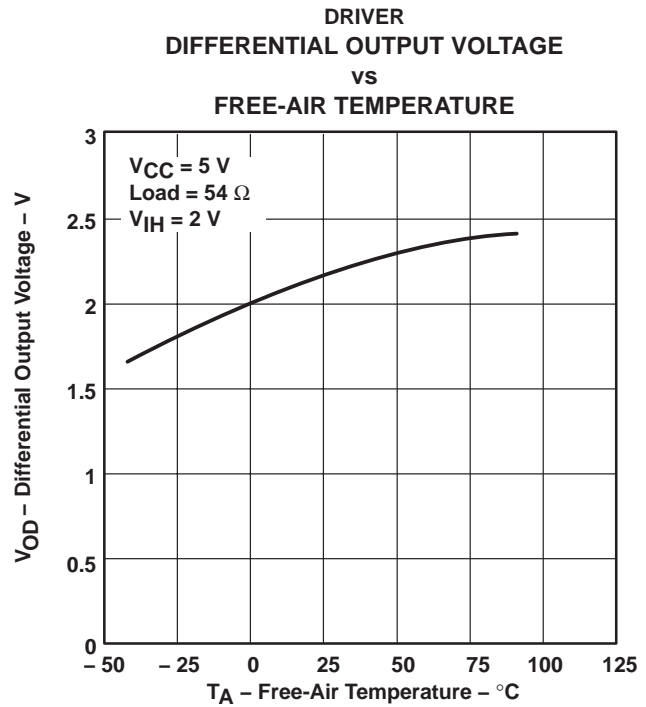

Figure 11



TYPICAL CHARACTERISTICS

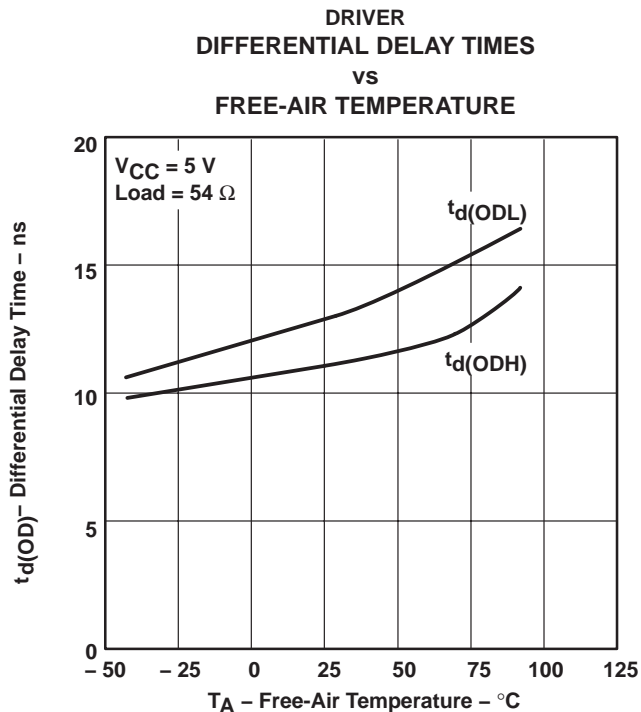

Figure 12

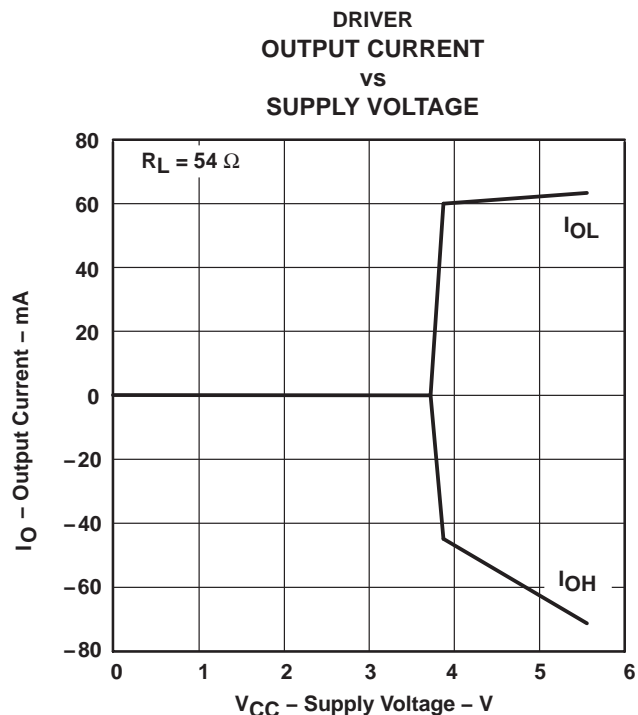

Figure 13

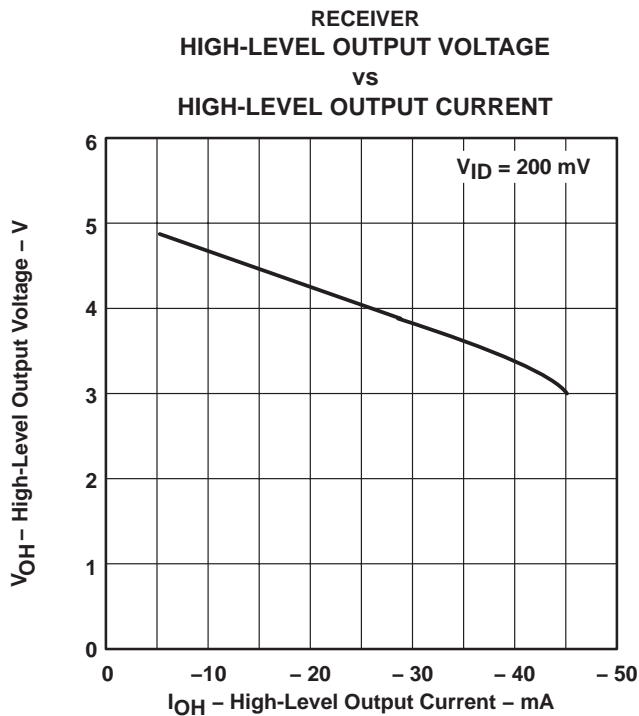

Figure 14

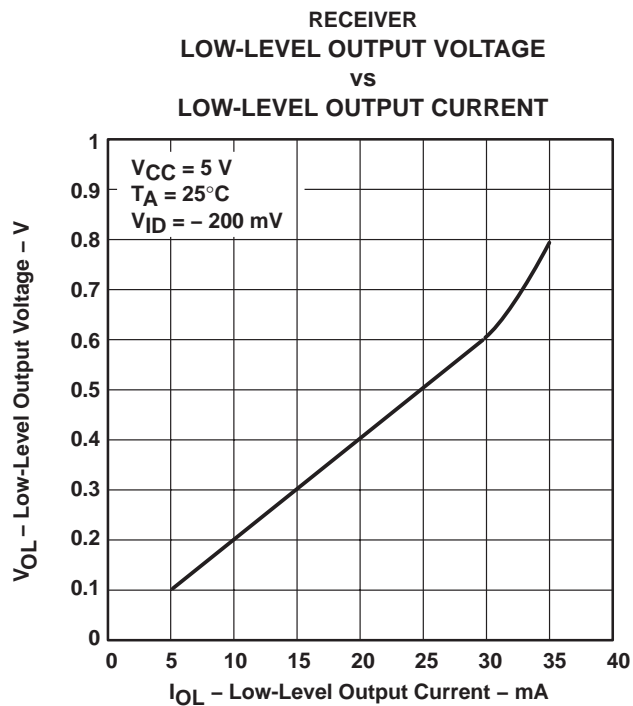

Figure 15

SN65LBC180-Q1

LOW-POWER DIFFERENTIAL LINE DRIVER AND RECEIVER PAIR

SGLS251A – JULY 2004 – REVISED JUNE 2008

TYPICAL CHARACTERISTICS

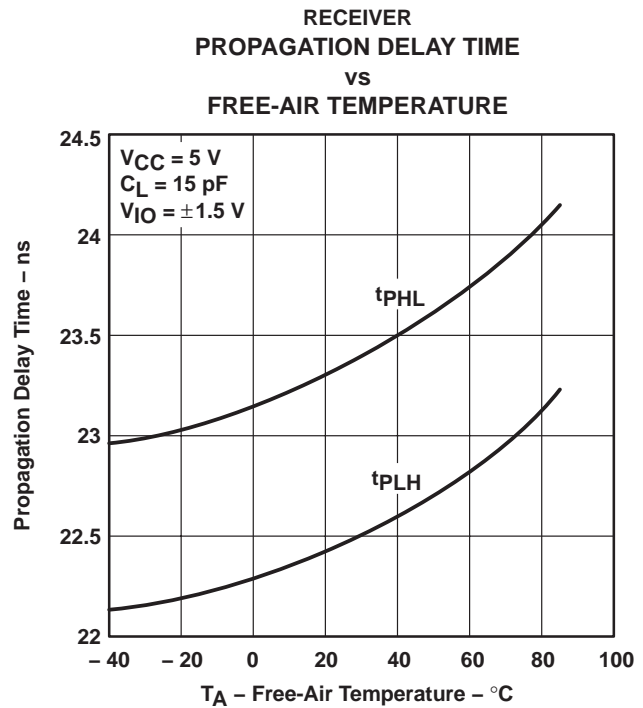
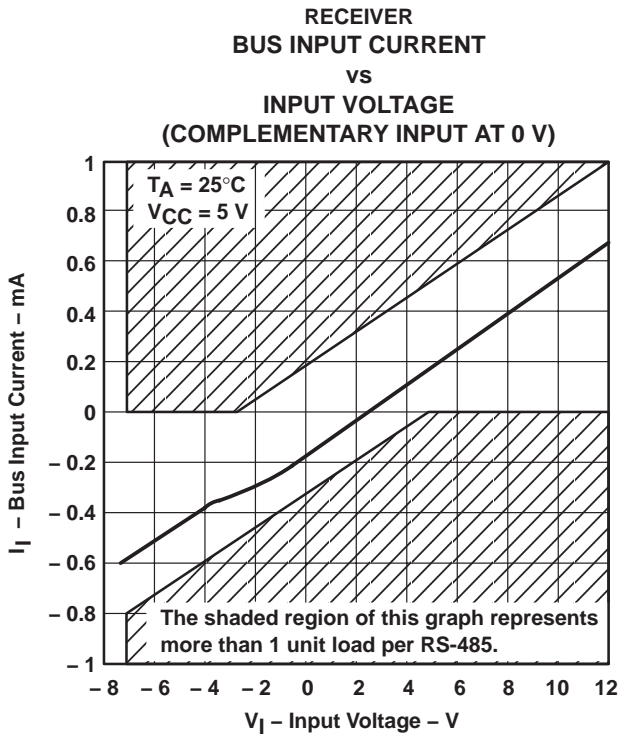
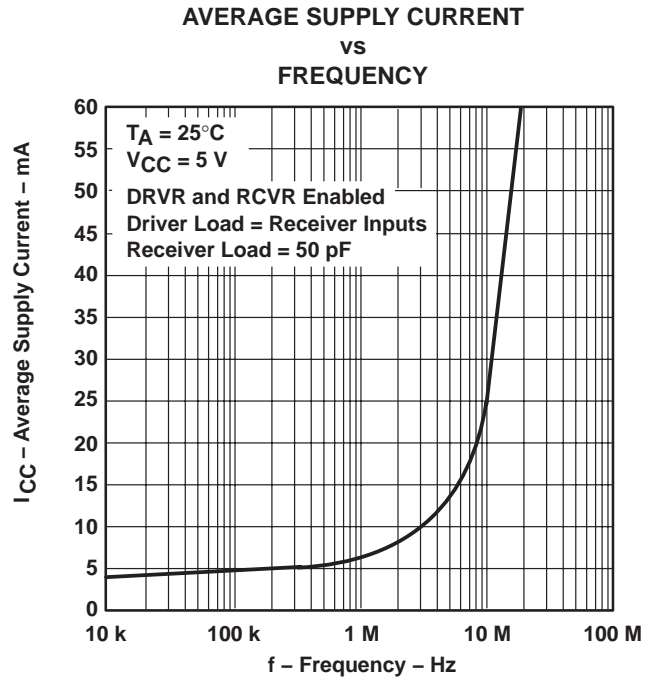
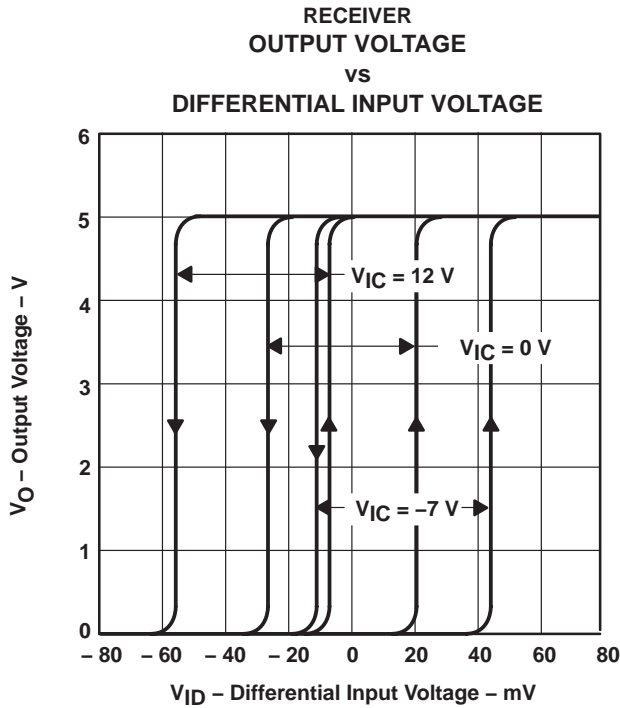

APPLICATION INFORMATION

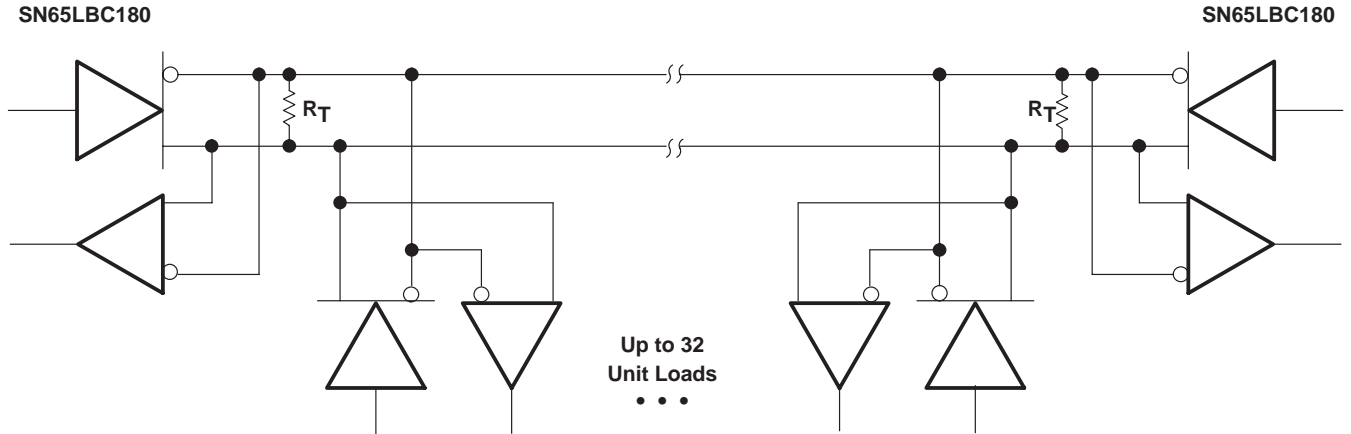

NOTE A: The line should be terminated at both ends in its characteristic impedance ($R_T = Z_0$). Stub lengths off the main line should be kept as short as possible. One SN65LBC180 typically represents less than one unit load.

Figure 20. Typical Application Circuit

PACKAGING INFORMATION

Orderable Device	Status (1)	Package Type	Package Drawing	Pins	Package Qty	Eco Plan (2)	Lead/Ball Finish	MSL Peak Temp (3)	Op Temp (°C)	Top-Side Markings (4)	Samples
SN65LBC180IDRG4Q1	ACTIVE	SOIC	D	14	2500	Green (RoHS & no Sb/Br)	CU NIPDAU	Level-1-260C-UNLIM	-40 to 85	BL180Q1	Samples
SN65LBC180IDRQ1	ACTIVE	SOIC	D	14	2500	Green (RoHS & no Sb/Br)	CU NIPDAU	Level-1-260C-UNLIM	-40 to 85	LBC180IQ1	Samples

(1) The marketing status values are defined as follows:

ACTIVE: Product device recommended for new designs.

LIFEBUY: TI has announced that the device will be discontinued, and a lifetime-buy period is in effect.

NRND: Not recommended for new designs. Device is in production to support existing customers, but TI does not recommend using this part in a new design.

PREVIEW: Device has been announced but is not in production. Samples may or may not be available.

OBSOLETE: TI has discontinued the production of the device.

(2) Eco Plan - The planned eco-friendly classification: Pb-Free (RoHS), Pb-Free (RoHS Exempt), or Green (RoHS & no Sb/Br) - please check <http://www.ti.com/productcontent> for the latest availability information and additional product content details.

TBD: The Pb-Free/Green conversion plan has not been defined.

Pb-Free (RoHS): TI's terms "Lead-Free" or "Pb-Free" mean semiconductor products that are compatible with the current RoHS requirements for all 6 substances, including the requirement that lead not exceed 0.1% by weight in homogeneous materials. Where designed to be soldered at high temperatures, TI Pb-Free products are suitable for use in specified lead-free processes.

Pb-Free (RoHS Exempt): This component has a RoHS exemption for either 1) lead-based flip-chip solder bumps used between the die and package, or 2) lead-based die adhesive used between the die and leadframe. The component is otherwise considered Pb-Free (RoHS compatible) as defined above.

Green (RoHS & no Sb/Br): TI defines "Green" to mean Pb-Free (RoHS compatible), and free of Bromine (Br) and Antimony (Sb) based flame retardants (Br or Sb do not exceed 0.1% by weight in homogeneous material)

(3) MSL, Peak Temp. -- The Moisture Sensitivity Level rating according to the JEDEC industry standard classifications, and peak solder temperature.

(4) Multiple Top-Side Markings will be inside parentheses. Only one Top-Side Marking contained in parentheses and separated by a "~" will appear on a device. If a line is indented then it is a continuation of the previous line and the two combined represent the entire Top-Side Marking for that device.

Important Information and Disclaimer: The information provided on this page represents TI's knowledge and belief as of the date that it is provided. TI bases its knowledge and belief on information provided by third parties, and makes no representation or warranty as to the accuracy of such information. Efforts are underway to better integrate information from third parties. TI has taken and continues to take reasonable steps to provide representative and accurate information but may not have conducted destructive testing or chemical analysis on incoming materials and chemicals. TI and TI suppliers consider certain information to be proprietary, and thus CAS numbers and other limited information may not be available for release.

In no event shall TI's liability arising out of such information exceed the total purchase price of the TI part(s) at issue in this document sold by TI to Customer on an annual basis.

OTHER QUALIFIED VERSIONS OF SN65LBC180-Q1 :

- Catalog: [SN65LBC180](#)

NOTE: Qualified Version Definitions:

- Catalog - TI's standard catalog product

TAPE AND REEL INFORMATION



QUADRANT ASSIGNMENTS FOR PIN 1 ORIENTATION IN TAPE



*All dimensions are nominal

Device	Package Type	Package Drawing	Pins	SPQ	Reel Diameter (mm)	Reel Width W1 (mm)	A0 (mm)	B0 (mm)	K0 (mm)	P1 (mm)	W (mm)	Pin1 Quadrant
SN65LBC180IDRG4Q1	SOIC	D	14	2500	330.0	16.4	6.5	9.0	2.1	8.0	16.0	Q1

TAPE AND REEL BOX DIMENSIONS



*All dimensions are nominal

Device	Package Type	Package Drawing	Pins	SPQ	Length (mm)	Width (mm)	Height (mm)
SN65LBC180IDRG4Q1	SOIC	D	14	2500	367.0	367.0	38.0

D (R-PDSO-G14)

PLASTIC SMALL OUTLINE



- NOTES:
- All linear dimensions are in millimeters.
 - This drawing is subject to change without notice.
 - Publication IPC-7351 is recommended for alternate designs.
 - Laser cutting apertures with trapezoidal walls and also rounding corners will offer better paste release. Customers should contact their board assembly site for stencil design recommendations. Refer to IPC-7525 for other stencil recommendations.
 - Customers should contact their board fabrication site for solder mask tolerances between and around signal pads.

IMPORTANT NOTICE

Texas Instruments Incorporated and its subsidiaries (TI) reserve the right to make corrections, enhancements, improvements and other changes to its semiconductor products and services per JESD46, latest issue, and to discontinue any product or service per JESD48, latest issue. Buyers should obtain the latest relevant information before placing orders and should verify that such information is current and complete. All semiconductor products (also referred to herein as "components") are sold subject to TI's terms and conditions of sale supplied at the time of order acknowledgment.

TI warrants performance of its components to the specifications applicable at the time of sale, in accordance with the warranty in TI's terms and conditions of sale of semiconductor products. Testing and other quality control techniques are used to the extent TI deems necessary to support this warranty. Except where mandated by applicable law, testing of all parameters of each component is not necessarily performed.

TI assumes no liability for applications assistance or the design of Buyers' products. Buyers are responsible for their products and applications using TI components. To minimize the risks associated with Buyers' products and applications, Buyers should provide adequate design and operating safeguards.

TI does not warrant or represent that any license, either express or implied, is granted under any patent right, copyright, mask work right, or other intellectual property right relating to any combination, machine, or process in which TI components or services are used. Information published by TI regarding third-party products or services does not constitute a license to use such products or services or a warranty or endorsement thereof. Use of such information may require a license from a third party under the patents or other intellectual property of the third party, or a license from TI under the patents or other intellectual property of TI.

Reproduction of significant portions of TI information in TI data books or data sheets is permissible only if reproduction is without alteration and is accompanied by all associated warranties, conditions, limitations, and notices. TI is not responsible or liable for such altered documentation. Information of third parties may be subject to additional restrictions.

Resale of TI components or services with statements different from or beyond the parameters stated by TI for that component or service voids all express and any implied warranties for the associated TI component or service and is an unfair and deceptive business practice. TI is not responsible or liable for any such statements.

Buyer acknowledges and agrees that it is solely responsible for compliance with all legal, regulatory and safety-related requirements concerning its products, and any use of TI components in its applications, notwithstanding any applications-related information or support that may be provided by TI. Buyer represents and agrees that it has all the necessary expertise to create and implement safeguards which anticipate dangerous consequences of failures, monitor failures and their consequences, lessen the likelihood of failures that might cause harm and take appropriate remedial actions. Buyer will fully indemnify TI and its representatives against any damages arising out of the use of any TI components in safety-critical applications.

In some cases, TI components may be promoted specifically to facilitate safety-related applications. With such components, TI's goal is to help enable customers to design and create their own end-product solutions that meet applicable functional safety standards and requirements. Nonetheless, such components are subject to these terms.

No TI components are authorized for use in FDA Class III (or similar life-critical medical equipment) unless authorized officers of the parties have executed a special agreement specifically governing such use.

Only those TI components which TI has specifically designated as military grade or "enhanced plastic" are designed and intended for use in military/aerospace applications or environments. Buyer acknowledges and agrees that any military or aerospace use of TI components which have *not* been so designated is solely at the Buyer's risk, and that Buyer is solely responsible for compliance with all legal and regulatory requirements in connection with such use.

TI has specifically designated certain components as meeting ISO/TS16949 requirements, mainly for automotive use. In any case of use of non-designated products, TI will not be responsible for any failure to meet ISO/TS16949.

Products

Audio	www.ti.com/audio
Amplifiers	amplifier.ti.com
Data Converters	dataconverter.ti.com
DLP® Products	www.dlp.com
DSP	dsp.ti.com
Clocks and Timers	www.ti.com/clocks
Interface	interface.ti.com
Logic	logic.ti.com
Power Mgmt	power.ti.com
Microcontrollers	microcontroller.ti.com
RFID	www.ti-rfid.com
OMAP Applications Processors	www.ti.com/omap
Wireless Connectivity	www.ti.com/wirelessconnectivity

Applications

Automotive and Transportation	www.ti.com/automotive
Communications and Telecom	www.ti.com/communications
Computers and Peripherals	www.ti.com/computers
Consumer Electronics	www.ti.com/consumer-apps
Energy and Lighting	www.ti.com/energy
Industrial	www.ti.com/industrial
Medical	www.ti.com/medical
Security	www.ti.com/security
Space, Avionics and Defense	www.ti.com/space-avionics-defense
Video and Imaging	www.ti.com/video

TI E2E Community

e2e.ti.com