



CAN TRANSCEIVER

FEATURES

- Qualified for Automotive Applications
- Drop-In Improved Replacement for the PCA82C250 and PCA82C251
- Bus-Fault Protection of ± 36 V
- Meets or Exceeds ISO 11898
- Signaling Rates⁽¹⁾ up to 1 Mbps
- High Input Impedance Allows up to 120 SN65HVD251 Nodes on a Bus
- Bus Pins ESD Protection Exceeds 9 kV (HBM)
- Unpowered Node Does Not Disturb the Bus
- Low-Current Standby Mode: 200 μ A Typical
- Thermal Shutdown Protection
- Glitch-Free Power-Up and Power-Down Bus Protection for Hot Plugging
- DeviceNet™ Vendor ID #806

⁽¹⁾ The signaling rate of a line is the number of voltage transitions that are made per second expressed in bps (bits per second).

APPLICATIONS

- CAN Data Buses
- Industrial Automation
 - DeviceNet Data Buses
 - Smart Distributed Systems (SDS™)
- SAE J1939 Standard Data Bus Interface
- NMEA 2000 Standard Data Bus Interface
- ISO 11783 Standard Data Bus Interface

DESCRIPTION

The SN65HVD251 is intended for use in applications employing the Controller Area Network (CAN) serial communication physical layer in accordance with the ISO 11898 Standard. The SN65HVD251 provides differential transmit capability to the bus and differential receive capability to a CAN controller at speeds up to 1 megabit per second (Mbps).

Designed for operation in harsh environments, the device features crosswire, overvoltage, and loss of ground protection to ± 36 V. Also featured are overtemperature protection as well as -7 -V to 12-V common-mode range, and tolerance to transients of ± 200 V. The transceiver interfaces the single-ended CAN controller with the differential CAN bus found in industrial, building automation, and automotive applications.

Rs, pin 8, selects one of three different modes of operation: high-speed, slope control, or low-power mode. The high-speed mode of operation is selected by connecting pin 8 to ground, allowing the transmitter output transistors to switch as fast as possible with no limitation on the rise and fall slope. The rise and fall slope can be adjusted by connecting a resistor to ground at pin 8; the slope is proportional to the pin's output current. Slope control with an external resistor value of 10 k Ω gives ~ 15 V/ μ s slew rate; 100 k Ω gives ~ 2 V/ μ s slew rate.

If a high logic level is applied to the Rs pin 8, the device enters a low-current standby mode where the driver is switched off and the receiver remains active. The local protocol controller returns the device to the normal mode when it transmits to the bus.

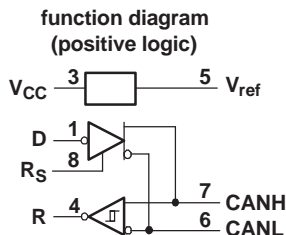
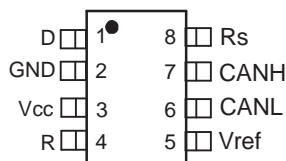

Please be aware that an important notice concerning availability, standard warranty, and use in critical applications of Texas Instruments semiconductor products and disclaimers thereto appears at the end of this data sheet.

All trademarks are the property of their respective owners.



These devices have limited built-in ESD protection. The leads should be shorted together or the device placed in conductive foam during storage or handling to prevent electrostatic damage to the MOS gates.

ORDERING INFORMATION⁽¹⁾

PART NUMBER	PACKAGE	MARKED AS
SN65HVD251QDRQ1	8-pin SOIC (Tape and Reel)	251Q1

(1) For the most current package and ordering information, see the Package Option Addendum at the end of this document, or see the TI web site at www.ti.com.

ABSOLUTE MAXIMUM RATINGS

over operating free-air temperature range (unless otherwise noted)⁽¹⁾⁽²⁾

			SN65HVD251
Supply voltage range, V_{CC}			–0.3 V to 7 V
Voltage range at any bus terminal		CANH, CANL	–36 V to 36 V
Transient voltage per ISO 7637, pulse 1, 2, 3a, 3b		CANH, CANL	±200 V
Input voltage range, V_I		D, Rs, R	–0.3 V to $V_{CC} + 0.5$
Receiver output current, I_O			–10 mA to 10 mA
Electrostatic discharge	Human-Body Model ⁽³⁾	CANH, CANL, GND	9 kV
		All pins	6 kV
	Charged-Device Model ⁽⁴⁾	All pins	1 kV
		Machine Model	All pins
Continuous total power dissipation			See Dissipation Rating Table

- (1) Stresses beyond those listed under "absolute maximum ratings" may cause permanent damage to the device. These are stress ratings only and functional operation of the device at these or any other conditions beyond those indicated under "recommended operating conditions" is not implied. Exposure to absolute-maximum-rated conditions for extended periods may affect device reliability.
- (2) All voltage values, except differential I/O bus voltages, are with respect to network ground terminal.
- (3) Tested in accordance with JEDEC Standard 22, Test Method A114-A
- (4) Tested in accordance with JEDEC Standard 22, Test Method C101

ABSOLUTE MAXIMUM POWER DISSIPATION RATINGS

PACKAGE	CIRCUIT BOARD MODEL	$T_A = 25^\circ\text{C}$ POWER RATING	DERATING FACTOR ⁽¹⁾ ABOVE $T_A = 25^\circ\text{C}$	$T_A = 85^\circ\text{C}$ POWER RATING	$T_A = 125^\circ\text{C}$ POWER RATING
SOIC (D)	Low-K ⁽²⁾	576 mW	4.8 mW/°C	288 mW	96 mW
	High-K ⁽³⁾	924 mW	7.7 mW/°C	462 mW	154 mW

- (1) This is the inverse of the junction-to-ambient thermal resistance when board-mounted and with no air flow.
- (2) In accordance with the Low-K thermal metric definitions of EIA/JESD51-3
- (3) In accordance with the High-K thermal metric definitions of EIA/JESD51-7

THERMAL CHARACTERISTICS

PARAMETER	TEST CONDITIONS	VALUE			UNIT
		MIN	TYP	MAX	
θ_{JB} Junction-to-board thermal resistance			78.7		°C/W
θ_{JC} Junction-to-case thermal resistance			44.6		°C/W
P_D Device power dissipation	$V_{CC} = 5\text{ V}$, $T_J = 27^\circ\text{C}$, $R_L = 60\ \Omega$, R_S at 0 V, Input to D a 500-kHz 50% duty cycle square wave			97.7	mW
	$V_{CC} = 5.5\text{ V}$, $T_J = 130^\circ\text{C}$, $R_L = 60\ \Omega$, R_S at 0 V, Input to D a 500-kHz 50% duty cycle square wave			142	mW
T_{SD} Thermal shutdown junction temperature			165		°C

RECOMMENDED OPERATING CONDITIONS

over recommended operating conditions (unless otherwise noted)

PARAMETER		MIN	NOM	MAX	UNIT
Supply voltage, V_{CC}		4.5		5.5	V
Voltage at any bus terminal (separately or common mode) V_I or V_{IC}		$-7^{(1)}$		12	V
High-level input voltage, V_{IH}	D input	$0.7 V_{CC}$			V
Low-level input voltage, V_{IL}	D input			$0.3 V_{CC}$	V
Differential input voltage, V_{ID}		-6		6	V
Input voltage to R_S , $V_{I(R_S)}$		0		V_{CC}	V
Input voltage at R_S for standby, $V_{I(R_S)}$		$0.75 V_{CC}$		V_{CC}	V
R_S wave-shaping resistance		0		100	k Ω
High-level output current, I_{OH}	Driver	-50			mA
	Receiver	-4			
Low-level output current, I_{OL}	Driver			50	mA
	Receiver			4	
Operating free-air temperature, T_A		-40		125	°C
Junction temperature, T_j				145	°C

(1) The algebraic convention, in which the least positive (most negative) limit is designated as minimum is used in this data sheet.

DRIVER ELECTRICAL CHARACTERISTICS

over recommended operating conditions (unless otherwise noted)

PARAMETER		TEST CONDITIONS	MIN	TYP ⁽¹⁾	MAX	UNIT	
V _{OD(D)}	Bus output voltage (Dominant)	CANH	Figure 1 and Figure 2, D at 0 V, Rs at 0 V			V	
		CANL	2.75	3.5	4.5		
V _{OD(R)}	Bus output voltage (Recessive)	CANH	Figure 1 and Figure 2, D at 0.7 V _{CC} , Rs at 0 V			V	
		CANL	0.5		2		
V _{OD(D)}	Differential output voltage (Dominant)	Figure 1, D at 0 V, Rs at 0 V	2	2.5	3	V	
V _{OD(D)}	Differential output voltage (Dominant)	Figure 2 and Figure 3, D at 0 V, Rs at 0 V	1.5	2	3	V	
V _{OD(R)}	Differential output voltage (Recessive)	Figure 1 and Figure 2, D at 0.7 V _{CC}	–120		12	mV	
V _{OD(R)}	Differential output voltage (Recessive)	D at 0.7 V _{CC} , No load	–0.5		0.05	V	
V _{OC(pp)}	Peak-to-peak common-mode output voltage	Figure 9, Rs at 0 V		600		mV	
I _{IH}	High-level input current, D input	D at 0.7 V _{CC}	–40		0	μA	
I _{IL}	Low-level input current, D input	D at 0.3 V _{CC}	–60		0	μA	
I _{OS(SS)}	Short-circuit steady-state output current	Figure 11, V _{CANH} at –7 V, CANL open	–200			mA	
		Figure 11, V _{CANH} at 12 V, CANL open					
		Figure 11, V _{CANL} at –7 V, CANH open	–2				
		Figure 11, V _{CANL} at 12 V, CANH open	2.5				
C _O	Output capacitance	See receiver input capacitance					
I _{OZ}	High-impedance output current	See receiver input current					
I _{IRs(s)}	Rs input current for standby	Rs at 0.75 V _{CC}	–10			μA	
I _{IRs(f)}	Rs input current for full-speed operation	Rs at 0 V	–550		0	μA	
I _{CC}	Supply current	Standby	Rs at V _{CC} , D at V _{CC}			275	μA
		Dominant	D at 0 V, 60-Ω load, Rs at 0 V			65	mA
		Recessive	D at V _{CC} , No load, Rs at 0 V			14	

(1) All typical values are at 25°C and with a 5-V supply.

DRIVER SWITCHING CHARACTERISTICS

over recommended operating conditions (unless otherwise noted)

PARAMETER		TEST CONDITIONS	MIN	TYP	MAX	UNIT
t _{pLH}	Propagation delay time, low-to-high-level output	Figure 4, Rs at 0 V		40	70	ns
		Figure 4, Rs with 10 kΩ to ground		90	125	
		Figure 4, Rs with 100 kΩ to ground		500	800	
t _{pHL}	Propagation delay time, high-to-low-level output	Figure 4, Rs at 0 V		85	125	ns
		Figure 4, Rs with 10 kΩ to ground		200	260	
		Figure 4, Rs with 100 kΩ to ground		1150	1450	
t _{sk(p)}	Pulse skew (t _{pHL} – t _{pLH})	Figure 4, Rs at 0 V		45	85	ns
		Figure 4, Rs with 10 kΩ to ground		110	180	
		Figure 4, Rs with 100 kΩ to ground		650	900	
t _r	Differential output signal rise time	Figure 4, Rs at 0 V	35		100	ns
t _f	Differential output signal fall time		35		100	ns
t _r	Differential output signal rise time	Figure 4, Rs with 10 kΩ to ground	100		250	ns
t _f	Differential output signal fall time		100		250	ns
t _r	Differential output signal rise time	Figure 4, Rs with 100 kΩ to ground	600		1550	ns
t _f	Differential output signal fall time		600		1550	ns
t _{en}	Enable time from standby to dominant	Figure 8			0.5	μs

RECEIVER ELECTRICAL CHARACTERISTICS

over recommended operating conditions (unless otherwise noted)

PARAMETER		TEST CONDITIONS	MIN	TYP	MAX	UNIT
V_{IT+}	Positive-going input threshold voltage	R_s at 0 V, (See Table 1)		750	900	mV
V_{IT-}	Negative-going input threshold voltage			500	650	
V_{hys}	Hysteresis voltage ($V_{IT+} - V_{IT-}$)			100		
V_{OH}	High-level output voltage	Figure 6 , $I_O = -4$ mA	0.8 V_{CC}			V
V_{OL}	Low-level output voltage	Figure 6 , $I_O = 4$ mA			0.2 V_{CC}	V
I_I	Bus input current	CANH or CANL at 12 V			600	A
		CANH or CANL at 12 V, V_{CC} at 0 V			715	
		CANH or CANL at -7 V	Other bus pin at 0 V, R_s at 0 V, D at 0.7 V_{CC}		-460	
		CANH or CANL at -7 V, V_{CC} at 0 V			-340	
C_I	Input capacitance (CANH or CANL)	Pin-to-ground, $V_I = 0.4 \sin(4E6\pi t) + 0.5$ V, D at 0.7 V_{CC}	20			pF
C_{ID}	Differential input capacitance	Pin-to-pin, $V_I = 0.4 \sin(4E6\pi t) + 0.5$ V, D at 0.7 V_{CC}	10			pF
R_{ID}	Differential input resistance	D at 0.7 V_{CC} , R_s at 0 V	40		100	k Ω
R_{IN}	Input resistance (CANH or CANL)	D at 0.7 V_{CC} , R_s at 0 V	20		50	k Ω
I_{CC}	Supply current	Standby	R_s at V_{CC} , D at V_{CC}		275	mA
		Dominant	D at 0 V, 60- Ω load, R_s at 0 V		65	
		Recessive	D at V_{CC} , No load, R_s at 0 V		14	

RECEIVER SWITCHING CHARACTERISTICS

over recommended operating conditions (unless otherwise noted)

PARAMETER		TEST CONDITIONS	MIN	TYP	MAX	UNIT
t_{pLH}	Propagation delay time, low-to-high-level output	Figure 6		35	50	ns
t_{pHL}	Propagation delay time, high-to-low-level output			35	50	ns
$t_{sk(p)}$	Pulse skew ($t_{pHL} - t_{pLH}$)				20	ns
t_r	Output signal rise time			2	4	ns
t_f	Output signal fall time			2	4	ns
$t_{p(sb)}$	Propagation delay time in standby		Figure 12 , R_s at V_{CC}			500

VREF PIN CHARACTERISTICS

over recommended operating conditions (unless otherwise noted)

PARAMETER		TEST CONDITIONS	MIN	MAX	UNIT
V_O	Reference output voltage	$-5 \mu A < I_O < 5 \mu A$	0.45 V_{CC}	0.55 V_{CC}	V
		$-50 \mu A < I_O < 50 \mu A$	0.4 V_{CC}	0.6 V_{CC}	

DEVICE SWITCHING CHARACTERISTICS

over recommended operating conditions (unless otherwise noted)

PARAMETER		TEST CONDITIONS	MIN	TYP	MAX	UNIT
t_{loop1}	Total loop delay, driver input to receiver output, recessive to dominant	Figure 10, Rs at 0 V		60	100	ns
		Figure 10, Rs with 10 k Ω to ground		100	150	
		Figure 10, Rs with 100 k Ω to ground		440	800	
t_{loop2}	Total loop delay, driver input to receiver output, dominant to recessive	Figure 10, Rs at 0 V		115	150	ns
		Figure 10, Rs with 10 k Ω to ground		235	290	
		Figure 10, Rs with 100 k Ω to ground		1070	1450	
t_{loop2}	Total loop delay, driver input to receiver output, dominant to recessive	Figure 10, Rs at 0 V, V_{CC} from 4.5 V to 5.1 V		105	145	ns

PARAMETER MEASUREMENT INFORMATION

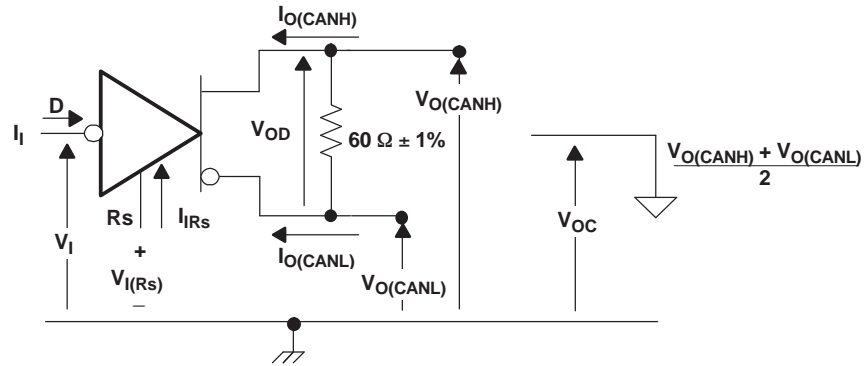

Figure 1. Driver Voltage, Current, and Test Definition

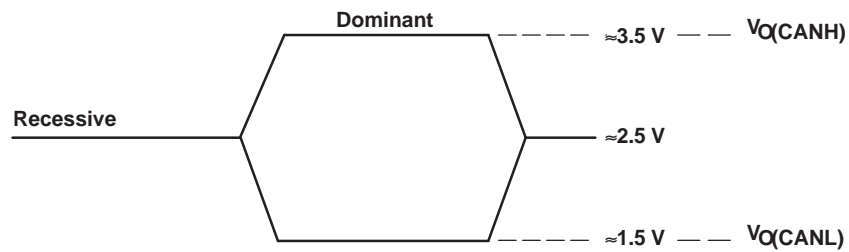

Figure 2. Bus Logic State Voltage Definitions

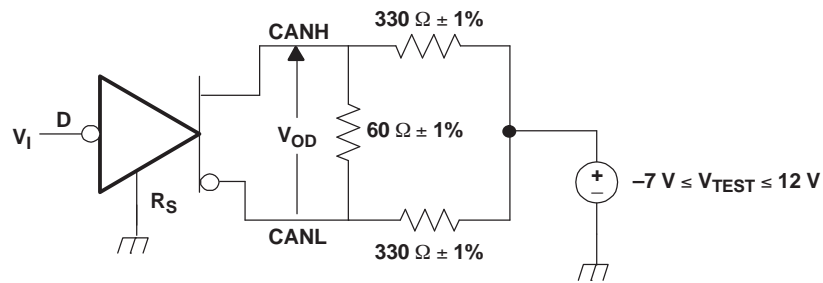

Figure 3. Driver V_{OD}

PARAMETER MEASUREMENT INFORMATION (continued)

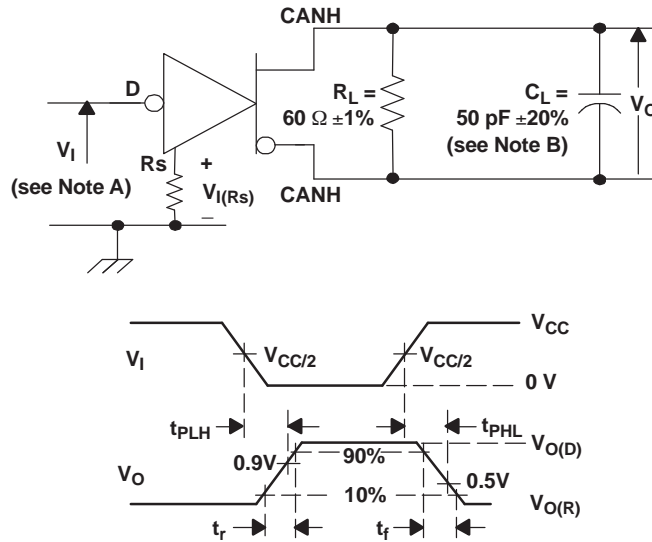

Figure 4. Driver Test Circuit and Voltage Waveforms

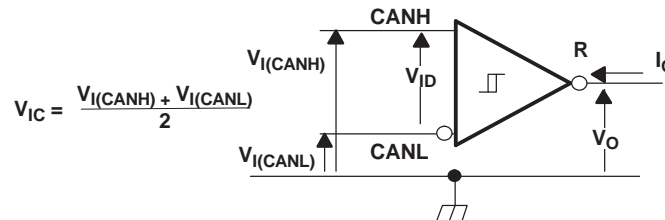
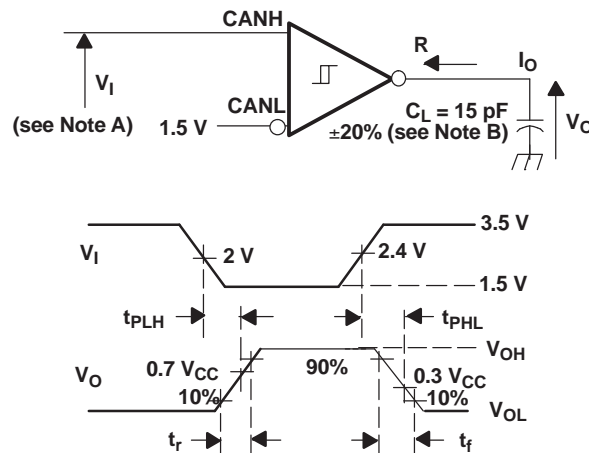

Figure 5. Receiver Voltage and Current Definitions



- A. The input pulse is supplied by a generator having the following characteristics: PRR ≤ 125 kHz, 50% duty cycle, t_r ≤ 6ns, t_f ≤ 6 ns, Z_O = 50 Ω.
- B. C_L includes instrumentation and fixture capacitance within ±20%.

Figure 6. Receiver Test Circuit and Voltage Waveforms

PARAMETER MEASUREMENT INFORMATION (continued)

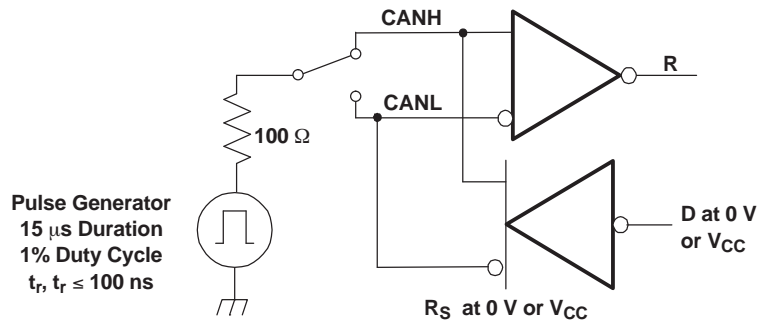

A. This test is conducted to test survivability only. Data stability at the R output is not specified.

Figure 7. Test Circuit, Transient Overvoltage Test

Table 1. Receiver Characteristics Over Common Mode Voltage

INPUT		MEASURED	OUTPUT	
V_{CANH}	V_{CANL}	$ V_{ID} $	R	
12 V	11.1 V	900 mV	L	V_{OL}
-6.1 V	-7 V	900 mV	L	
-1 V	-7 V	6 V	L	
12 V	6 V	6 V	L	
-6.5 V	-7 V	500 mV	H	V_{OH}
12 V	11.5 V	500 mV	H	
-7 V	-1 V	6 V	H	
6 V	12 V	6 V	H	
open	open	X	H	

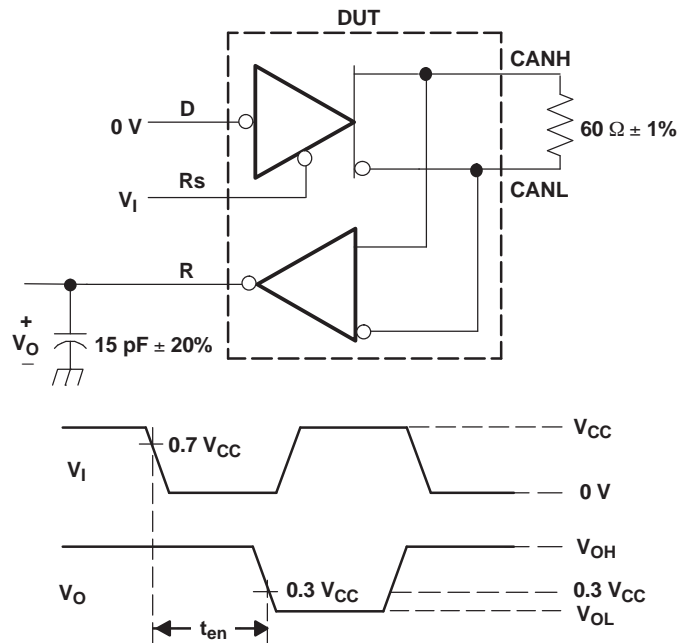
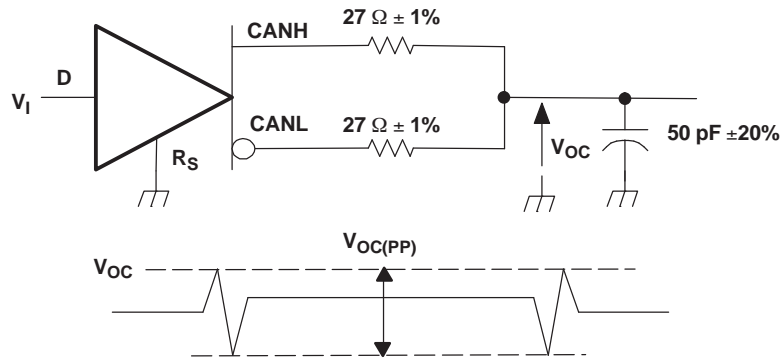

Figure 8. t_{en} Test Circuit and Voltage Waveforms



- A. The input pulse is supplied by a generator having the following characteristics: PRR \leq 125 kHz, 50% duty cycle, $t_r \leq 6$ ns, $t_f \leq 6$ ns, $Z_O = 50 \Omega$.

Figure 9. Peak-to-Peak Common Mode Output Voltage

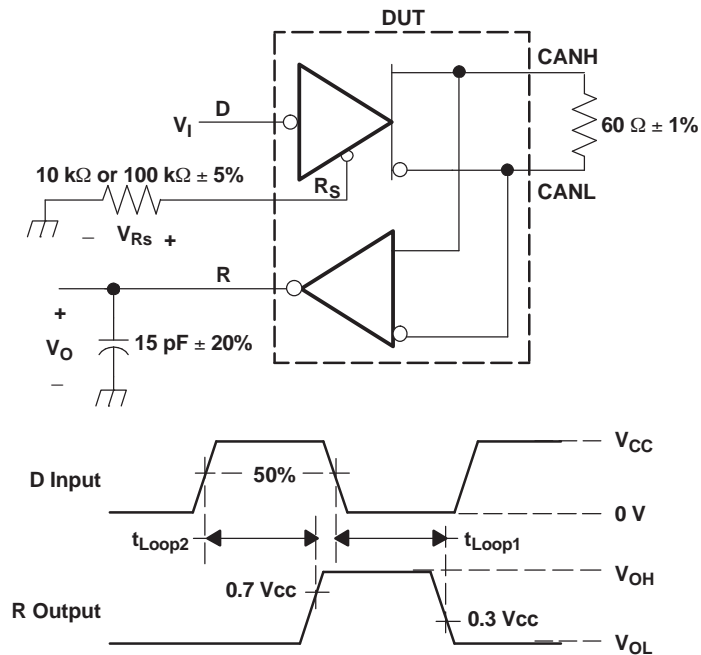

Figure 10. t_{LOOP} Test Circuit and Voltage Waveforms

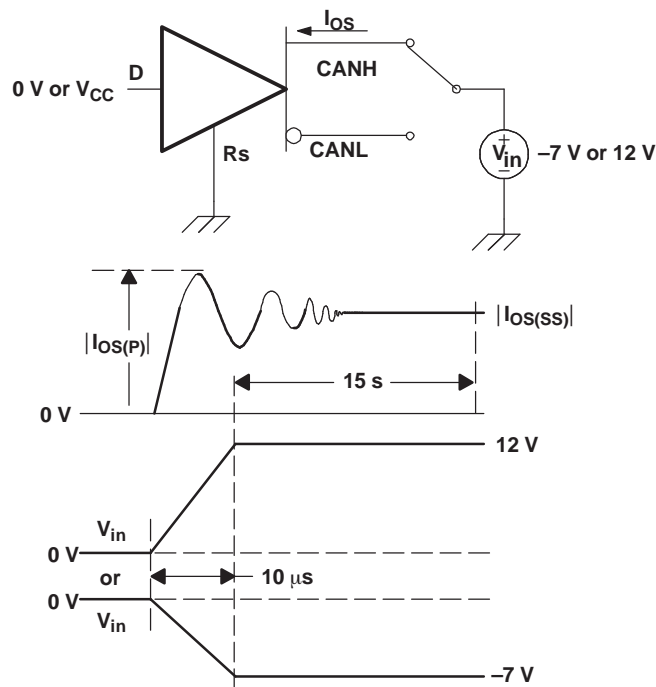
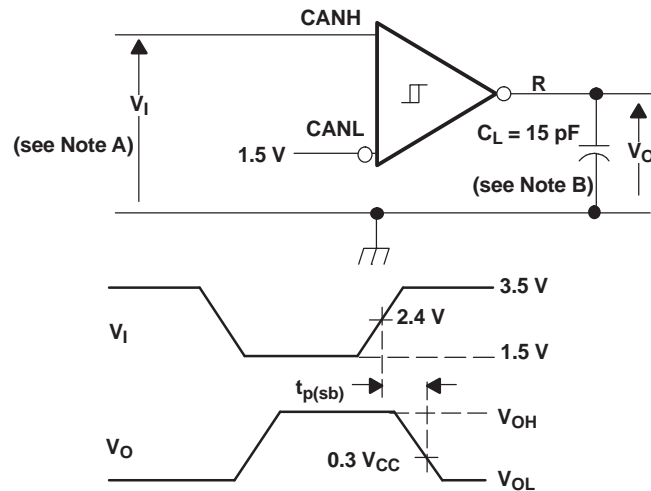

Figure 11. Driver Short-Circuit Test



- A. The input pulse is supplied by a generator having the following characteristics: $PRR \leq 125$ kHz, 50% duty cycle, $t_r \leq 6$ ns, $t_f \leq 6$ ns, $Z_O = 50 \Omega$.
- B. C_L includes instrumentation and fixture capacitance within $\pm 20\%$.

Figure 12. Receiver Propagation Delay in Standby Test Circuit and Waveforms

DEVICE INFORMATION

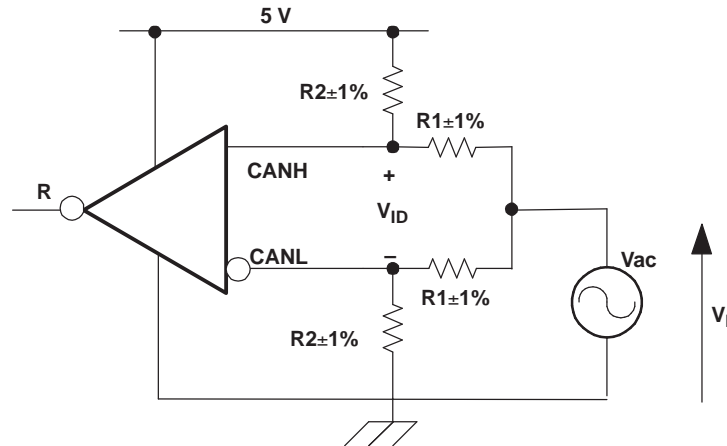

V_{ID}	R1	R2
500 mV	50 Ω	450 Ω
900 mV	50 Ω	227 Ω



A. All input pulses are supplied by a generator having the following characteristics: $f < 1.5$ MHz, $T_A = 25^\circ\text{C}$, $V_{CC} = 5$ V.

Figure 13. Common-Mode Input Voltage Rejection Test

FUNCTION TABLES

Table 2. DRIVER

INPUTS D	Voltage at R_s , V_{Rs}	OUTPUTS		BUS STATE
		CANH	CANL	
L	$V_{Rs} < 1.2$ V	H	L	Dominant
H	$V_{Rs} < 1.2$ V	Z	Z	Recessive
Open	X	Z	Z	Recessive
X	$V_{Rs} > 0.75 V_{CC}$	Z	Z	Recessive

Table 3. RECEIVER

DIFFERENTIAL INPUTS [$V_{ID} = V(\text{CANH}) - V(\text{CANL})$]	OUTPUT R ⁽¹⁾
$V_{ID} \geq 0.9$ V	L
$0.5\text{V} < V_{ID} < 0.9$ V	?
$V_{ID} \leq 0.5$ V	H
Open	H

(1) H = high level; L = low level; X = irrelevant; ? = indeterminate; Z = high impedance

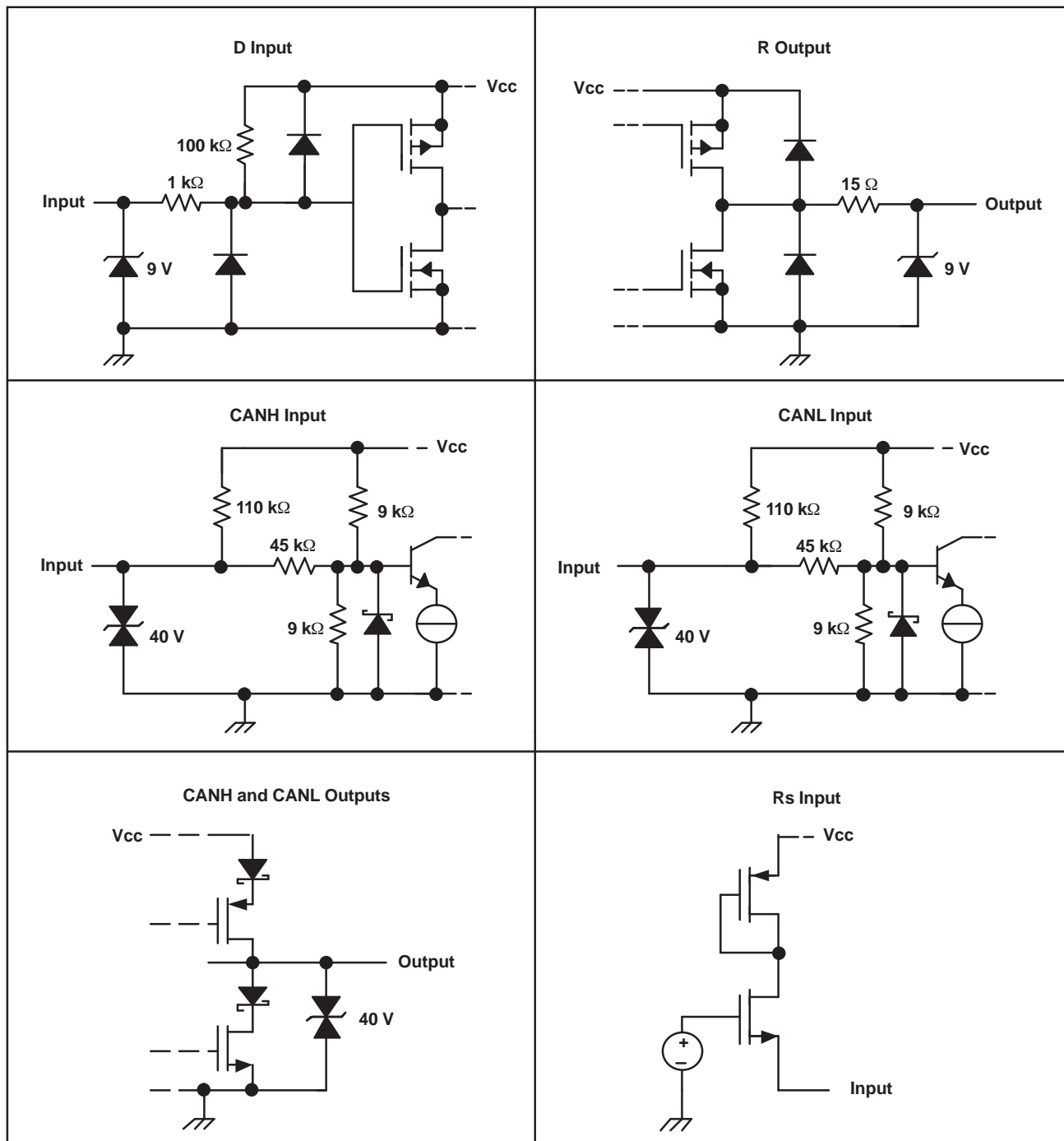

Figure 14. Equivalent Input and Output Schematic Diagrams

TYPICAL CHARACTERISTICS

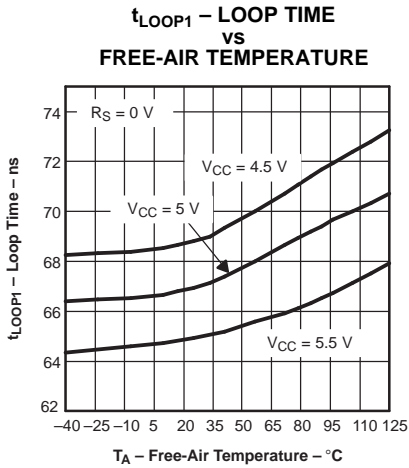

Figure 15.

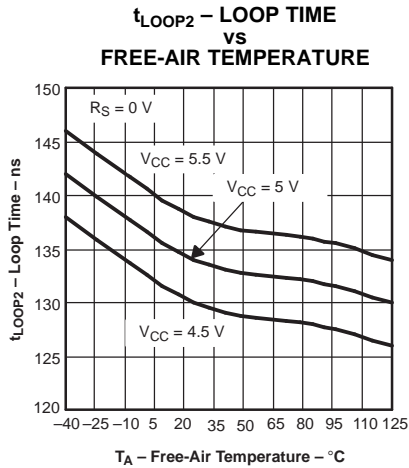

Figure 16.

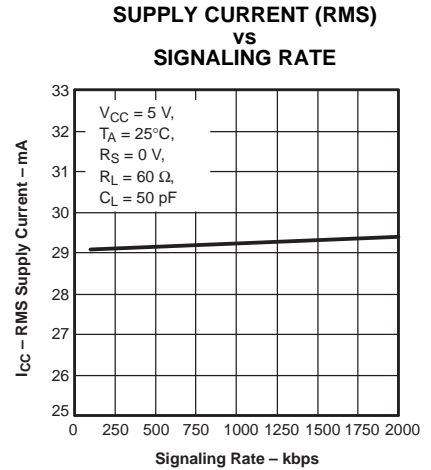

Figure 17.

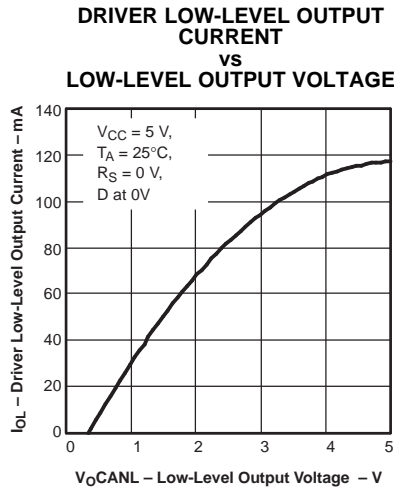

Figure 18.

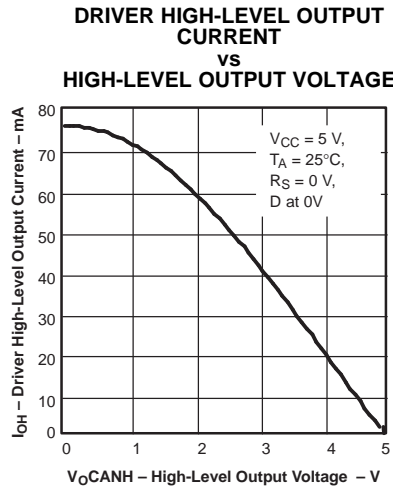

Figure 19.

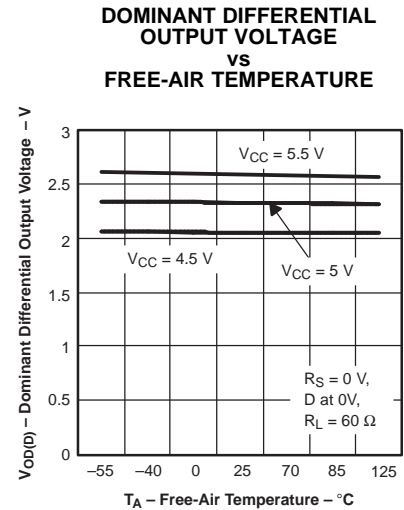

Figure 20.

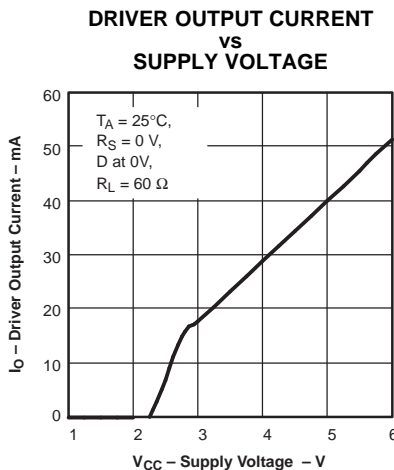

Figure 21.

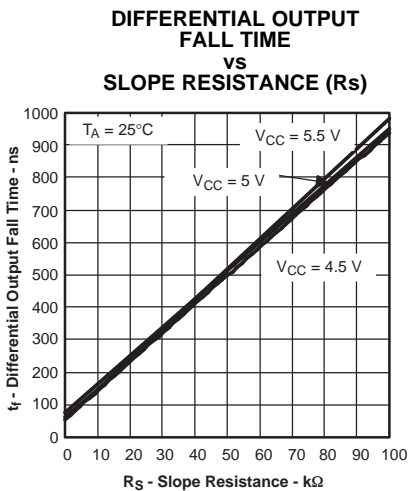

Figure 22.

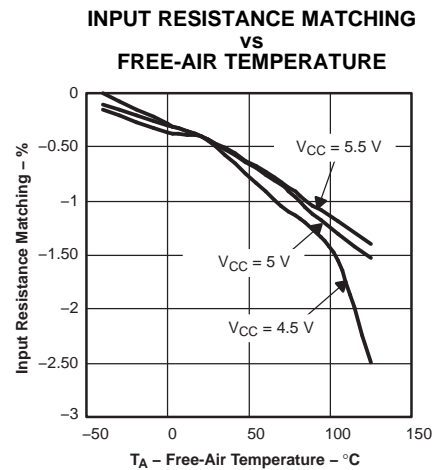

Figure 23.

APPLICATION INFORMATION

The basics of bus arbitration require that the receiver at the sending node designate the first bit as dominant or recessive after the initial wave of the first bit of a message travels to the most remote node on a network and back again. Typically, this *sample* is made at 75% of the bit width, and within this limitation, the maximum allowable signal distortion in a CAN network is determined by network electrical parameters.

Factors to be considered in network design include the 5 ns/m propagation delay of typical twisted-pair bus cable; signal amplitude loss due to the loss mechanisms of the cable; and the number, length, and spacing of drop-lines (stubs) on a network. Under strict analysis, variations among the different

oscillators in a system must also be accounted for with adjustments in signaling rate and stub and bus length. Table 4 lists the maximum signaling rates achieved with the SN65HVD251 in high-speed mode with several bus lengths of category 5, shielded twisted-pair (CAT 5 STP) cable.

Table 4. Maximum Signaling Rates for Various Cable Lengths

BUS LENGTH (m)	SIGNALING RATE (kbps)
30	1000
100	500
250	250
500	125
1000	62.5

The ISO 11898 standard specifies a maximum bus length of 40 m and maximum stub length of 0.3 m with a maximum of 30 nodes. However, with careful design, users can have longer cables, longer stub lengths, and many more nodes on a bus. (Note: Non-standard application may come with a trade-off in signaling rate.) A bus with a large number of nodes requires a transceiver with high input impedance such as the HVD251.

The Standard specifies the interconnect to be a single twisted-pair cable (shielded or unshielded) with 120-Ω characteristic impedance (Z_0). Resistors equal to the characteristic impedance of the line terminate both ends of the cable to prevent signal reflections. Unterminated drop-lines connect nodes to the bus and should be kept as short as possible to minimize signal reflections.

Connectors, while not specified by the ISO 11898 standard, should have as little effect as possible on standard operating parameters such as capacitive loading. Although unshielded cable is used in many applications, data transmission circuits employing CAN transceivers are usually used in applications requiring a rugged interconnection with a wide common-mode voltage range. Therefore, shielded cable is recommended in these electronically harsh environments, and when coupled with the -2-V to 7-V common-mode range of tolerable ground noise specified in the standard, helps to ensure data integrity. The HVD251 extends data integrity beyond that of the standard with an extended -7-V to 12-V range of common-mode operation.

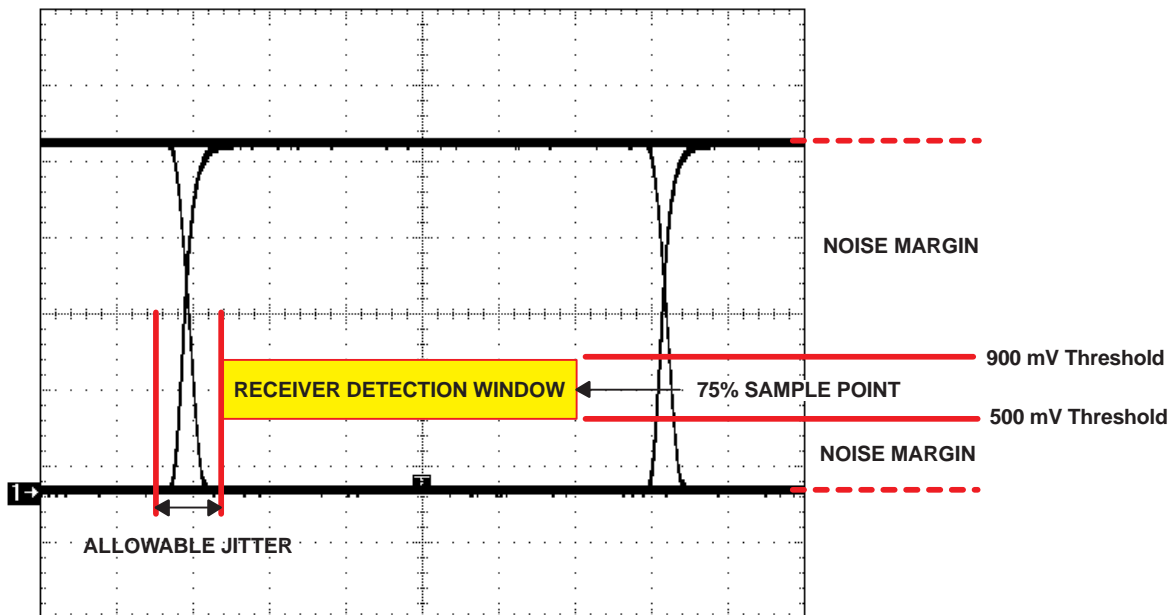

Figure 24. Typical CAN Differential Signal Eye Pattern

An eye pattern is a useful tool for measuring overall signal quality. As displayed in Figure 24, the differential signal changes logic states in two places on the display, producing an eye. Instead of viewing only one logic crossing on the scope, an entire *bit* of data is brought into view. The resulting eye pattern includes all effects of systemic and random distortion, and displays the time during which a signal may be considered valid.

The height of the eye above or below the receiver threshold voltage level at the sampling point is the noise margin of the system. Jitter is typically measured at the differential voltage zero-crossing during the logic state transition of a signal. Note that jitter present at the receiver threshold voltage level is considered by some to be a more effective representation of the jitter at the input of a receiver.

As the sum of skew and noise increases, the eye closes and data is corrupted. Closing the width decreases the time available for accurate sampling, and lowering the height enters the 900 mV or 500 mV threshold of a receiver.

Different sources induce noise onto a signal. The more obvious noise sources are the components of a transmission circuit themselves; the signal transmitter, traces and cables, connectors, and the receiver. Beyond that, there is a termination dependency, cross-talk from clock traces and other proximity effects, V_{CC} and ground bounce, and electromagnetic interference from nearby electrical equipment.

The balanced receiver inputs of the HVD251 mitigate most sources of signal corruption, and when used with a quality shielded twisted-pair cable, help ensure data integrity.

Typical Application

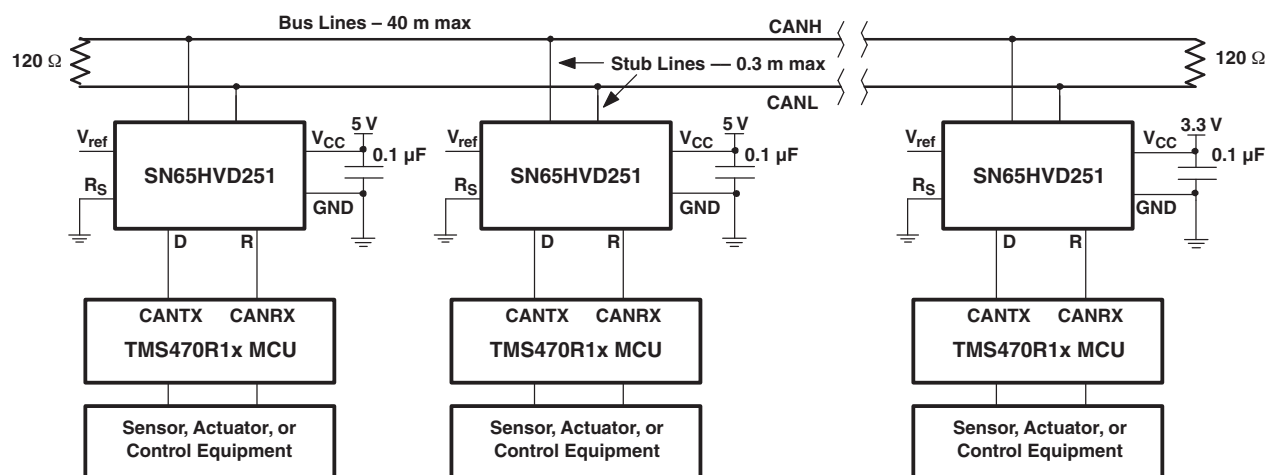

Figure 25. Typical HVD251 Application

PACKAGING INFORMATION

Orderable Device	Status (1)	Package Type	Package Drawing	Pins	Package Qty	Eco Plan (2)	Lead/Ball Finish	MSL Peak Temp (3)	Op Temp (°C)	Top-Side Markings (4)	Samples
SN65HVD251QDRQ1	ACTIVE	SOIC	D	8	2500	Green (RoHS & no Sb/Br)	CU NIPDAU	Level-1-260C-UNLIM	-40 to 125	251Q1	Samples

(1) The marketing status values are defined as follows:

ACTIVE: Product device recommended for new designs.

LIFEBUY: TI has announced that the device will be discontinued, and a lifetime-buy period is in effect.

NRND: Not recommended for new designs. Device is in production to support existing customers, but TI does not recommend using this part in a new design.

PREVIEW: Device has been announced but is not in production. Samples may or may not be available.

OBSELETE: TI has discontinued the production of the device.

(2) Eco Plan - The planned eco-friendly classification: Pb-Free (RoHS), Pb-Free (RoHS Exempt), or Green (RoHS & no Sb/Br) - please check <http://www.ti.com/productcontent> for the latest availability information and additional product content details.

TBD: The Pb-Free/Green conversion plan has not been defined.

Pb-Free (RoHS): TI's terms "Lead-Free" or "Pb-Free" mean semiconductor products that are compatible with the current RoHS requirements for all 6 substances, including the requirement that lead not exceed 0.1% by weight in homogeneous materials. Where designed to be soldered at high temperatures, TI Pb-Free products are suitable for use in specified lead-free processes.

Pb-Free (RoHS Exempt): This component has a RoHS exemption for either 1) lead-based flip-chip solder bumps used between the die and package, or 2) lead-based die adhesive used between the die and leadframe. The component is otherwise considered Pb-Free (RoHS compatible) as defined above.

Green (RoHS & no Sb/Br): TI defines "Green" to mean Pb-Free (RoHS compatible), and free of Bromine (Br) and Antimony (Sb) based flame retardants (Br or Sb do not exceed 0.1% by weight in homogeneous material)

(3) MSL, Peak Temp. -- The Moisture Sensitivity Level rating according to the JEDEC industry standard classifications, and peak solder temperature.

(4) Multiple Top-Side Markings will be inside parentheses. Only one Top-Side Marking contained in parentheses and separated by a "~" will appear on a device. If a line is indented then it is a continuation of the previous line and the two combined represent the entire Top-Side Marking for that device.

Important Information and Disclaimer:The information provided on this page represents TI's knowledge and belief as of the date that it is provided. TI bases its knowledge and belief on information provided by third parties, and makes no representation or warranty as to the accuracy of such information. Efforts are underway to better integrate information from third parties. TI has taken and continues to take reasonable steps to provide representative and accurate information but may not have conducted destructive testing or chemical analysis on incoming materials and chemicals. TI and TI suppliers consider certain information to be proprietary, and thus CAS numbers and other limited information may not be available for release.

In no event shall TI's liability arising out of such information exceed the total purchase price of the TI part(s) at issue in this document sold by TI to Customer on an annual basis.

OTHER QUALIFIED VERSIONS OF SN65HVD251-Q1 :

- Catalog: [SN65HVD251](#)

NOTE: Qualified Version Definitions:

- Catalog - TI's standard catalog product

D (R-PDSO-G8)

PLASTIC SMALL OUTLINE

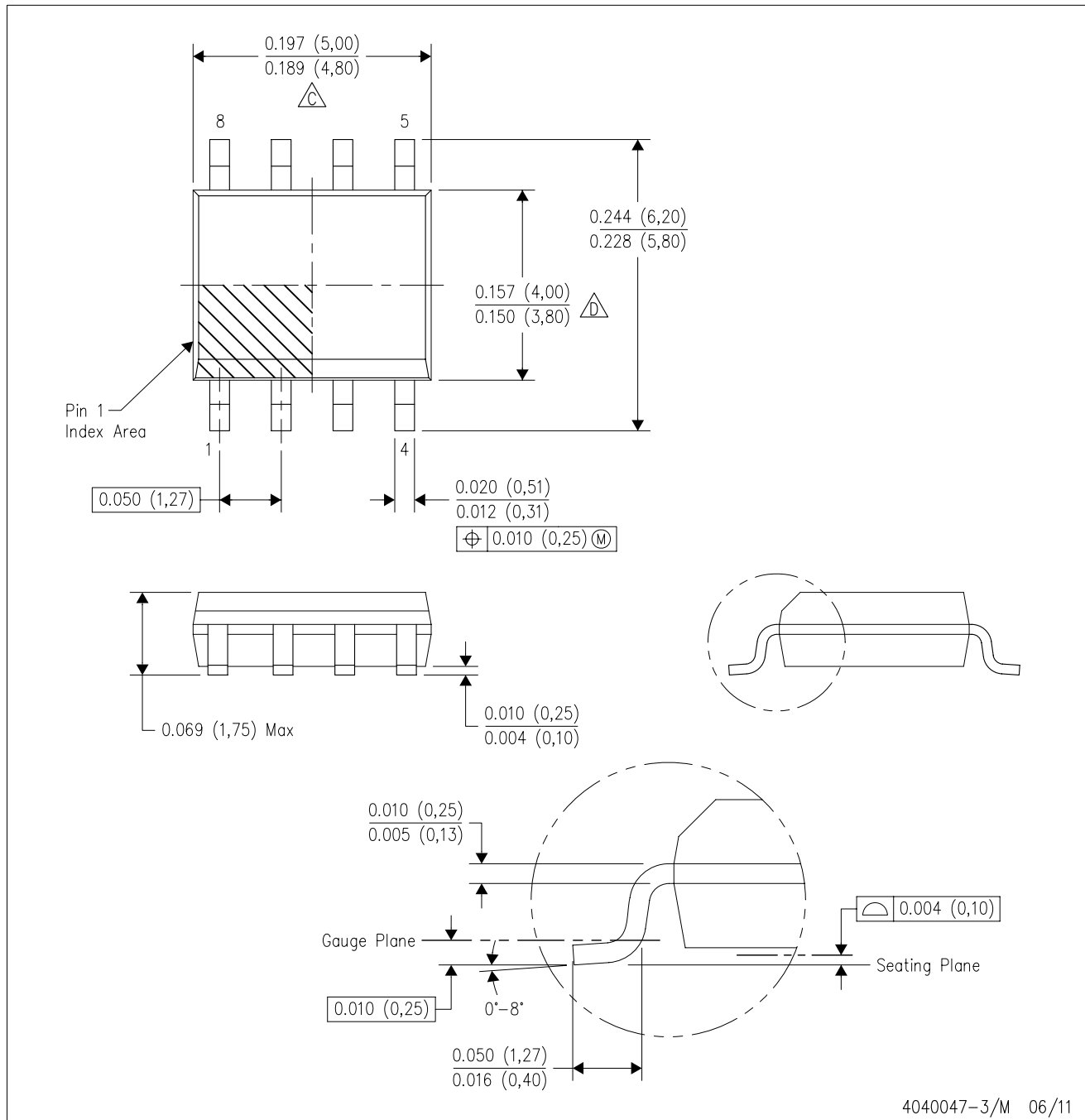

- NOTES:
- A. All linear dimensions are in inches (millimeters).
 - B. This drawing is subject to change without notice.
 - C. Body length does not include mold flash, protrusions, or gate burrs. Mold flash, protrusions, or gate burrs shall not exceed 0.006 (0,15) each side.
 - D. Body width does not include interlead flash. Interlead flash shall not exceed 0.017 (0,43) each side.
 - E. Reference JEDEC MS-012 variation AA.

D (R-PDSO-G8)

PLASTIC SMALL OUTLINE

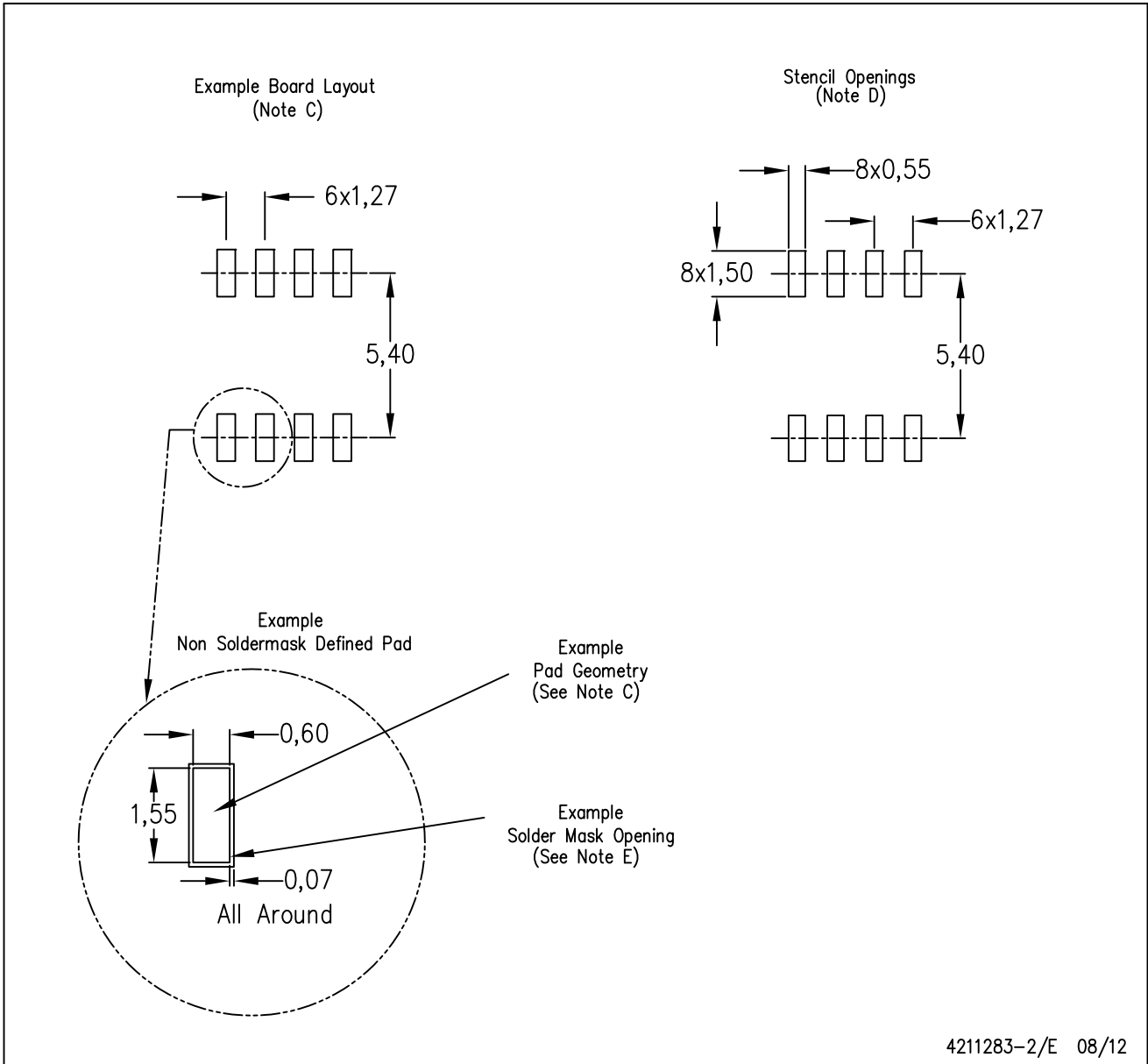

- NOTES:
- A. All linear dimensions are in millimeters.
 - B. This drawing is subject to change without notice.
 - C. Publication IPC-7351 is recommended for alternate designs.
 - D. Laser cutting apertures with trapezoidal walls and also rounding corners will offer better paste release. Customers should contact their board assembly site for stencil design recommendations. Refer to IPC-7525 for other stencil recommendations.
 - E. Customers should contact their board fabrication site for solder mask tolerances between and around signal pads.

IMPORTANT NOTICE

Texas Instruments Incorporated and its subsidiaries (TI) reserve the right to make corrections, enhancements, improvements and other changes to its semiconductor products and services per JESD46, latest issue, and to discontinue any product or service per JESD48, latest issue. Buyers should obtain the latest relevant information before placing orders and should verify that such information is current and complete. All semiconductor products (also referred to herein as "components") are sold subject to TI's terms and conditions of sale supplied at the time of order acknowledgment.

TI warrants performance of its components to the specifications applicable at the time of sale, in accordance with the warranty in TI's terms and conditions of sale of semiconductor products. Testing and other quality control techniques are used to the extent TI deems necessary to support this warranty. Except where mandated by applicable law, testing of all parameters of each component is not necessarily performed.

TI assumes no liability for applications assistance or the design of Buyers' products. Buyers are responsible for their products and applications using TI components. To minimize the risks associated with Buyers' products and applications, Buyers should provide adequate design and operating safeguards.

TI does not warrant or represent that any license, either express or implied, is granted under any patent right, copyright, mask work right, or other intellectual property right relating to any combination, machine, or process in which TI components or services are used. Information published by TI regarding third-party products or services does not constitute a license to use such products or services or a warranty or endorsement thereof. Use of such information may require a license from a third party under the patents or other intellectual property of the third party, or a license from TI under the patents or other intellectual property of TI.

Reproduction of significant portions of TI information in TI data books or data sheets is permissible only if reproduction is without alteration and is accompanied by all associated warranties, conditions, limitations, and notices. TI is not responsible or liable for such altered documentation. Information of third parties may be subject to additional restrictions.

Resale of TI components or services with statements different from or beyond the parameters stated by TI for that component or service voids all express and any implied warranties for the associated TI component or service and is an unfair and deceptive business practice. TI is not responsible or liable for any such statements.

Buyer acknowledges and agrees that it is solely responsible for compliance with all legal, regulatory and safety-related requirements concerning its products, and any use of TI components in its applications, notwithstanding any applications-related information or support that may be provided by TI. Buyer represents and agrees that it has all the necessary expertise to create and implement safeguards which anticipate dangerous consequences of failures, monitor failures and their consequences, lessen the likelihood of failures that might cause harm and take appropriate remedial actions. Buyer will fully indemnify TI and its representatives against any damages arising out of the use of any TI components in safety-critical applications.

In some cases, TI components may be promoted specifically to facilitate safety-related applications. With such components, TI's goal is to help enable customers to design and create their own end-product solutions that meet applicable functional safety standards and requirements. Nonetheless, such components are subject to these terms.

No TI components are authorized for use in FDA Class III (or similar life-critical medical equipment) unless authorized officers of the parties have executed a special agreement specifically governing such use.

Only those TI components which TI has specifically designated as military grade or "enhanced plastic" are designed and intended for use in military/aerospace applications or environments. Buyer acknowledges and agrees that any military or aerospace use of TI components which have **not** been so designated is solely at the Buyer's risk, and that Buyer is solely responsible for compliance with all legal and regulatory requirements in connection with such use.

TI has specifically designated certain components as meeting ISO/TS16949 requirements, mainly for automotive use. In any case of use of non-designated products, TI will not be responsible for any failure to meet ISO/TS16949.

Products

Audio	www.ti.com/audio
Amplifiers	amplifier.ti.com
Data Converters	dataconverter.ti.com
DLP® Products	www.dlp.com
DSP	dsp.ti.com
Clocks and Timers	www.ti.com/clocks
Interface	interface.ti.com
Logic	logic.ti.com
Power Mgmt	power.ti.com
Microcontrollers	microcontroller.ti.com
RFID	www.ti-rfid.com
OMAP Applications Processors	www.ti.com/omap
Wireless Connectivity	www.ti.com/wirelessconnectivity

Applications

Automotive and Transportation	www.ti.com/automotive
Communications and Telecom	www.ti.com/communications
Computers and Peripherals	www.ti.com/computers
Consumer Electronics	www.ti.com/consumer-apps
Energy and Lighting	www.ti.com/energy
Industrial	www.ti.com/industrial
Medical	www.ti.com/medical
Security	www.ti.com/security
Space, Avionics and Defense	www.ti.com/space-avionics-defense
Video and Imaging	www.ti.com/video

TI E2E Community

e2e.ti.com