

Data Sheet

SMS1508S-R

PUI Audio's **High-Temp** line of products is designed to meet and exceed the needs of the automotive industry with ultra-wide operating temperatures. The **SMS-1508MS-HT-R** is designed for high output at 800Hz in a small package.

- Wide -40°C to +105°C operating temperature
- 92 dB output at 10cm with 0.8W input
- Wide 400Hz to 10,000 Hz frequency range

### Specifications

Parameters	Values	Units
Rated Input Power	0.8	Watts
Max Input Power	1.0	Watts
Impedance	8±20%	Ohms
Sensitivity @ 1k, 1.6k, 2.0k & 3.2kHz Ave	92±3	dB
Resonant Frequency	800±15%	Hz
Frequency Range	400 ~ 10,000	Hz
Weight	1.7	Grams
Acceptable Soldering Methods	Hand Solder, Reflow	See below for soldering information
Environmental Compliances	RoHS	-
Storage Temperature	-40 ~ +105	°C
Operating Temperature	-40 ~ +105	°C

### Measurement Method (0.8W sine sweep, microphone spaced at 10cm, speaker in 1cc enclosure)

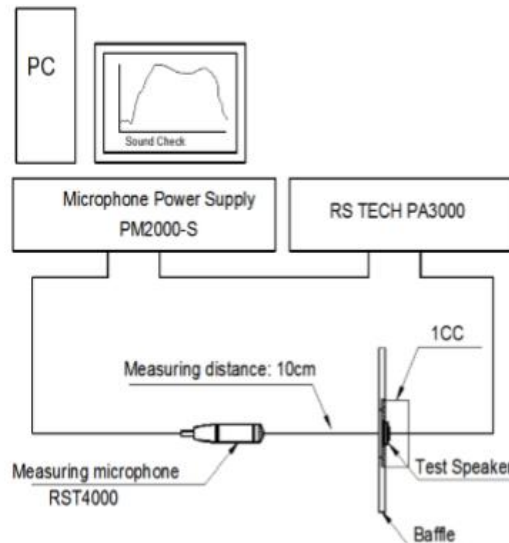

## Typical Frequency Response (0.8W sine-sweep with microphone spaced at 10cm)

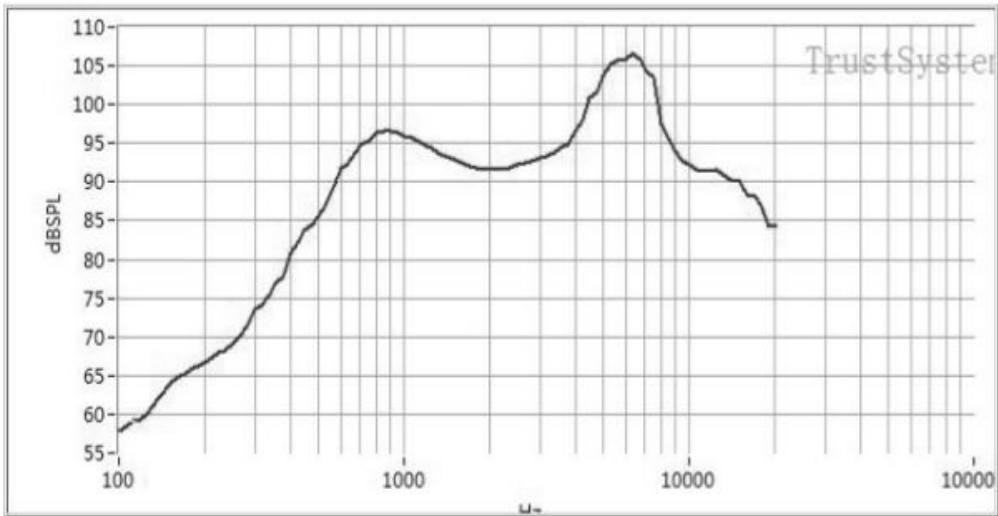

## Recommended Soldering Procedure

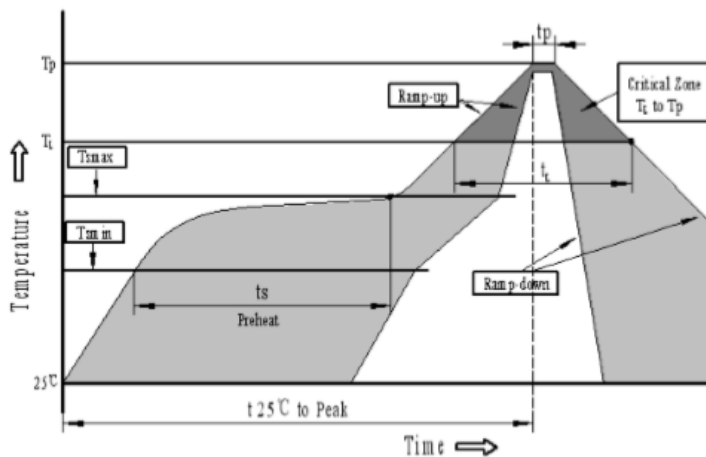

Profile Feature	Pb-Free Assembly
Average ramp-up rate( $T_L$ to $T_p$ )	3°C/second max.
Preheat	
-Temperature Min. ( $T_{smin}$ )	150°C
-Temperature Min. ( $T_{smax}$ )	200°C
-Temperature Min. ( $t_s$ )	60~180 seconds
$T_{smax}$ to $T_L$	
-Ramp-up Rate	3°C/second max.
Time maintained above:	
- Temperature( $T_L$ )	217°C
-Time( $T_L$ )	60~150 seconds
Peak temperature( $T_p$ )	245°C+0/-5°C
Time within 5°C of actual Peak temperature ( $t_p$ )	6 seconds max.
Ramp-down Rate	6°C/second max.
Time 25°C to Peak Temperature	8 minutes max.



## Suggested Land Pattern\*

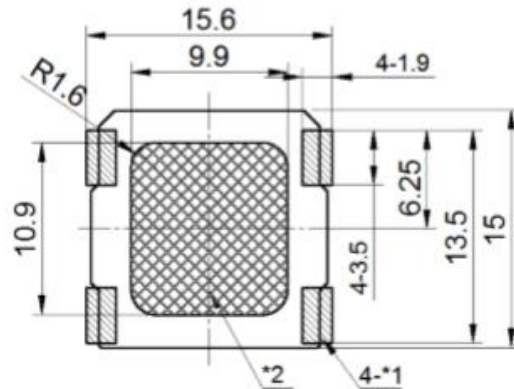

### NOTE

1. Land pattern\*1
2. Avoid any pattern on the shade area
- \*2 of PC board is highly recommended

\*This land pattern is advisory only and its use or adaptation is entirely voluntary. PUI Audio disclaims all liability of any kind associated with the use, application, or adaptation of this land pattern.

## Packaging

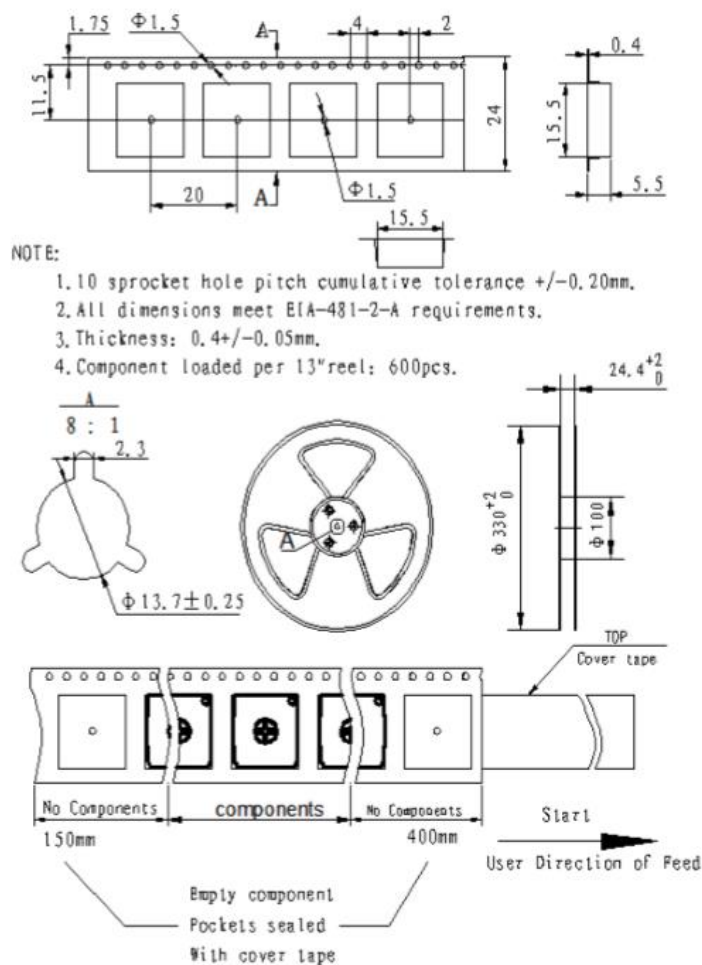

## Packaging (Cont'd)

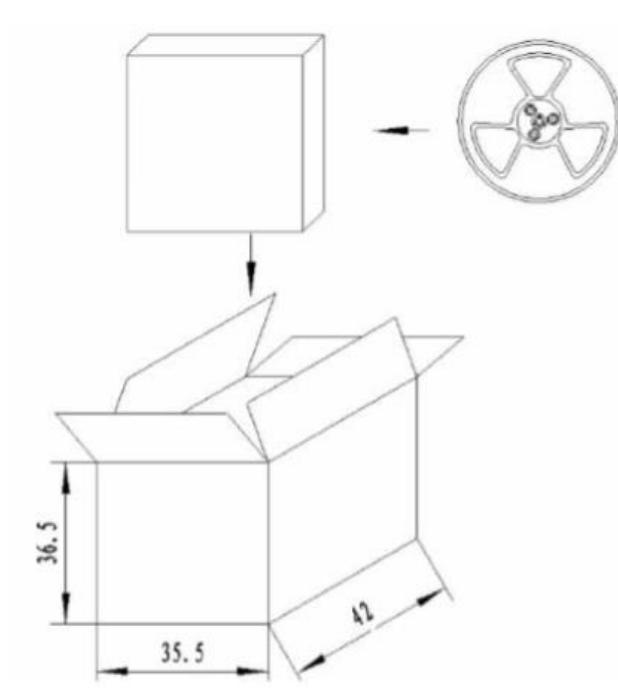

### NOTES:

- 1.600 PCS per box
- 2.Total 10 boxes per carton
- 3.Total 6000 PCS carton
- 4.Volume:42×35.5×36.5cm

**Specifications Revisions**

<b>Revision</b>	<b>Description</b>	<b>Date</b>
-	Released from Engineering	3/6/2020

Note:

- 1. Unless otherwise specified:
  - A. All dimensions are in millimeters.
  - B. Default tolerances are  $\pm 0.5\text{mm}$  and angles are  $\pm 3^\circ$ .
- 2. Specifications subject to change or withdrawal without notice.