

DATA SHEET

# SKY73009-11: 400 to 3000 MHz Direct Quadrature Demodulator

## Applications

- PCS, DCS, GSM/GPRS, and EDGE receivers
- Third generation (3G) wireless communications
- Power amplifier feedback/linearization
- Wireless local loops (WLLs)
- Wireless local area networks (WLANs)

## Features

- High IIP2 and IIP3
- Wideband RF input frequency range (400 to 3000 MHz)
- Wideband LO input frequency range (400 to 3000 MHz)
- Integrated LO balun
- Integrated LO amplifier
- On-chip I/Q phase splitter
- Differential IF output supports direct interface to A/D circuitry
- AM demodulation immunity
- Single +3.0 V supply
- RFLGA™ (32-pin, 5 x 5 mm) package (MSL3, 260 °C per JEDEC J-STD-020)



Skyworks Green™ products are compliant with all applicable legislation and are halogen-free. For additional information, refer to *Skyworks Definition of Green™*, document number SQ04-0074.

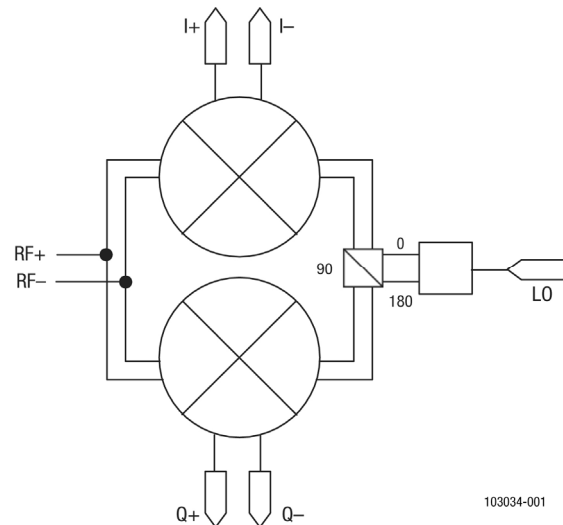

Figure 1. SKY73009-11 Block Diagram

## Description

The SKY73009-11 is an integrated, broadband, high-dynamic range quadrature demodulator for use in various wireless communication system applications. The SKY73009-11 can perform quadrature demodulation of RF input signals from 400 to 3000 MHz directly to baseband frequencies. The quadrature outputs are differential and can be directly connected to most commonly available A/D converters.

The high dynamic range and second order input intercept point (IIP2) value of the SKY73009-11 make it ideal for use in direct conversion and low intermediate frequency (IF) receivers.

Figure 1 shows a functional block diagram for the SKY73009-11. The device package and pinout are shown in Figure 2. Signal pins and descriptions are listed in Table 1.

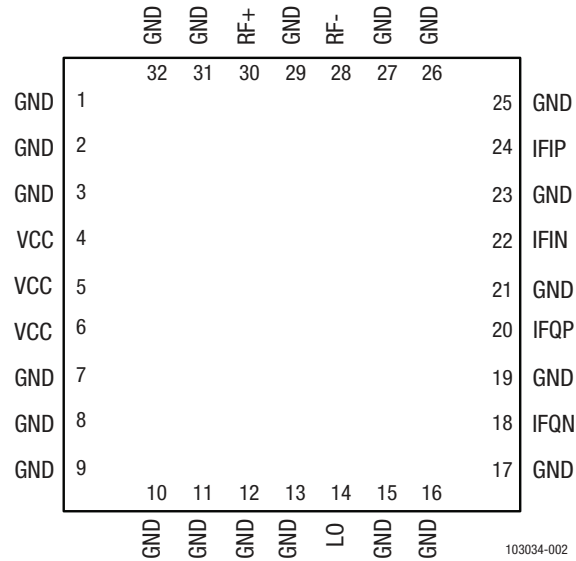

**Figure 2. SKY73009-11 Pinout (Top View)**

**Table 1. SKY73009-11 Signal Descriptions**

Pin	Name	Description	Pin	Name	Description
1	GND	Ground	17	GND	Ground
2	GND	Ground	18	IFQN	Negative quadrature IF output
3	GND	Ground	19	GND	Ground
4	VCC	+3 VDC supply	20	IFQP	Positive quadrature IF output
5	VCC	+3 VDC supply	21	GND	Ground
6	VCC	+3 VDC supply	22	IFIN	Negative in-phase IF output
7	GND	Ground	23	GND	Ground
8	GND	Ground	24	IFIP	Positive in-phase IF output
9	GND	Ground	25	GND	Ground
10	GND	Ground	26	GND	Ground
11	GND	Ground	27	GND	Ground
12	GND	Ground	28	RF-	Negative RF input
13	GND	Ground	29	GND	Ground
14	LO	LO input	30	RF+	Positive RF input
15	GND	Ground	31	GND	Ground
16	GND	Ground	32	GND	Ground

## Electrical and Mechanical Specifications

The absolute maximum ratings of the SKY73009-11 are provided in Table 2. The recommended operating conditions are specified in Table 3. Electrical specifications are provided in Table 4.

## Equivalent Input Circuits

An equivalent circuit for the RF input of the SKY73009-11 is shown in Figure 3. The equivalent circuit for the local oscillator (LO) input is shown in Figure 4. An internal balun is used to convert the single-ended LO input into a differential signal before being buffered inside the device.

**Table 2. SKY73009-11 Absolute Maximum Ratings<sup>1</sup>**

Parameter	Symbol	Min	Typ	Max	Units
+3 V supply voltage	VCC	2.7		3.6	V
Power dissipation	P <sub>D</sub>		210	320	mW
RF input power	P <sub>RFIN</sub>			18	dBm
LO input power	P <sub>LOIN</sub>		0	6	dBm
Operating case temperature	T <sub>OPR</sub>	-40		+85	°C
Junction temperature	T <sub>J</sub>			150	°C
Thermal resistance	R <sub>JC</sub>			50	C/W
Storage case temperature	T <sub>STG</sub>	-55	0	+150	°C

<sup>1</sup> Exposure to maximum rating conditions for extended periods may reduce device reliability. There is no damage to device with only one parameter set at the limit and all other parameters set at or below their nominal value. Exceeding any of the limits listed here may result in permanent damage to the device.

---

**ESD HANDLING:** *Although this device is designed to be as robust as possible, electrostatic discharge (ESD) can damage this device. This device must be protected at all times from ESD when handling or transporting. Static charges may easily produce potentials of several kilovolts on the human body or equipment, which can discharge without detection. Industry-standard ESD handling precautions should be used at all times.*

---

**Table 3. SKY73009-11 Recommended Operating Conditions**

Parameter	Symbol	Min	Typ	Max	Units
+3 V supply voltage	VCC	2.7	3.0	3.3	V
Current consumption	I <sub>CC</sub>		75		mA
Operating case temperature	T <sub>OPR</sub>	-40		+85	°C

**Table 4. SKY73009-11 Electrical Characteristics**  
**(VCC = 3 V, IF = 10 MHz, LO Input Power = 0 dBm, Tc = 25 °C, Zo = 50 Ω, Unless Otherwise Noted)**

Parameter	Symbol	Test Conditions	Min	Typical	Max	Units
RF input frequency range			400		3000	MHz
LO input frequency range <sup>1</sup>			400		3000	MHz
IF frequency range			DC		250	MHz
I/Q amplitude imbalance			-0.3		+0.3	dB
I/Q phase error				1		deg
IF output impedance <sup>2</sup>				500		Ω
LO to RF isolation				50		dB
IF output DC level		Over process and operating temperature	0.95	1.20	1.55	V
<b>RF Input (900 MHz)</b>						
Voltage conversion gain			0	2		dB
SSB noise figure	NF			14	16	dB
Second order input intercept point	IIP2			60		dBm
Third order input intercept point	IIP3		24	27		dBm
-1 dB compression point			10	12		dBm
RF input VSWR				1.5:1	2.0:1	
LO input VSWR				1.5:1	2.0:1	
Noise floor				-166		dBm/Hz
<b>RF Input (1900 MHz)</b>						
Voltage conversion gain			-0.7	+1.3		dB
SSB noise figure	NF			15	17	dB
Second order input intercept point	IIP2			60		dBm
Third order input intercept point	IIP3		22	25		dBm
-1 dB compression point			11	13		dBm
RF input VSWR				1.5:1	2.0:1	
LO input VSWR				1.5:1	2.0:1	
Noise floor				-163		dBm/Hz

<sup>1</sup> For operation at LO frequencies <550 MHz and >2500 MHz, an LO power of +3 dBm must be used.

<sup>2</sup> Differential IFI and IFQ output impedance without the use of a 9:1 impedance ratio balun.

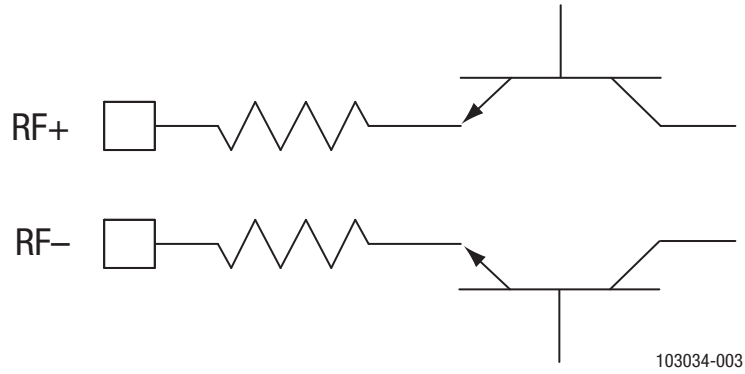

Figure 3. Equivalent Circuit for the RF input

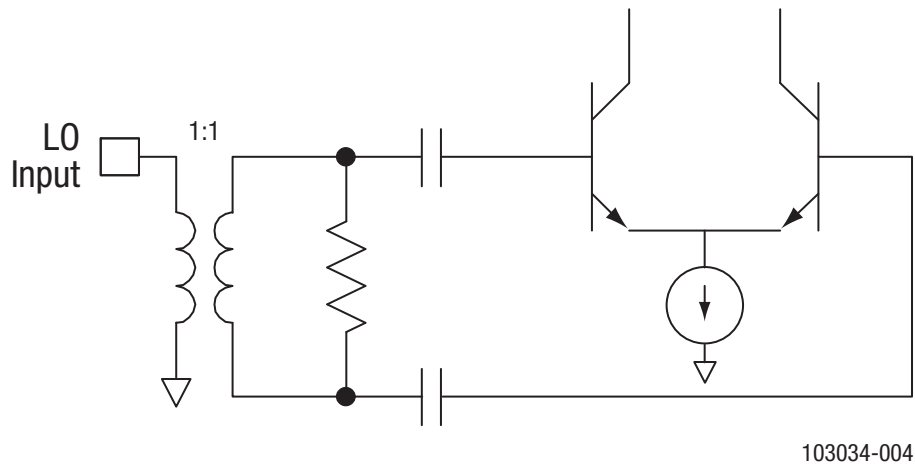

Figure 4. Equivalent Circuit for the LO input

## Evaluation Board Description

The SKY73009-11 Evaluation Board is used to test the performance of the SKY73009-11 direct quadrature demodulator. There are three Evaluation Boards for this device, each configured for a specific frequency range. Schematic diagrams and Bills of Materials (BOMs) for each board are presented in the following figures and tables:

- Figure 5 and Table 5 (800 to 1000 MHz)
- Figure 6 and Table 6 (1500 to 2500 MHz)
- Figure 7 and Table 7 (custom frequency)

The Evaluation Board assembly diagrams are shown in Figure 8 (800 to 1000 MHz), Figure 9 (1500 to 2500 MHz), and Figure 10 (custom frequency).

## EVB Testing Procedure

Use the following procedure to set up the SKY73009-11 Evaluation Board for testing. Refer to Figure 11 for guidance:

1. Connect a +3.0 VDC power supply using an insulated supply cable. If available, enable the current limiting function of the power supply to 100 mA.
2. Connect a signal generator to the RF signal input port. Set it to the desired RF frequency at a power level of 0 dBm to the Evaluation Board but do NOT enable the RF-signal.
3. Connect a signal generator to the LO signal input port. Set to the desired LO frequency at a power level of 0 dBm, but do not enable.
4. Connect a spectrum analyzer to the IFI signal output port and terminate the IFQ signal input port in  $50\Omega$ .
5. Enable the power supply.
6. Enable the LO input signal.
7. Enable the RF signal.
8. Take measurements and repeat these steps for channel Q.

---

**CAUTION:** *If any of the input signals exceed the rated maximum values, the SKY73009-11 Evaluation Board can be permanently damaged.*

---

## Circuit Design Considerations

The following design considerations are general in nature and must be followed regardless of final use or configuration:

- Paths to ground should be made as short as possible.
- The ground pad of the SKY73009-11 direct quadrature demodulator has special electrical and thermal grounding requirements. This pad is the main thermal conduit for heat dissipation. Since the circuit board acts as the heat sink, it must shunt as much heat as possible from the device. As such, design the connection to the ground pad to dissipate the maximum wattage produced to the circuitboard.
- Two external output bypass capacitors are required on the VCC pin. The values of these capacitors will change with respect to the desired RF frequency. One capacitor should be used for low frequency bypassing and the other capacitor for high frequency bypassing. Special attention should be given so that the smaller value capacitor does not go into self-resonance at the desired RF frequency.
- The RF input must be driven differentially. A 1:1 impedance ratio balun is recommended with a center tap on the secondary side that is DC grounded.

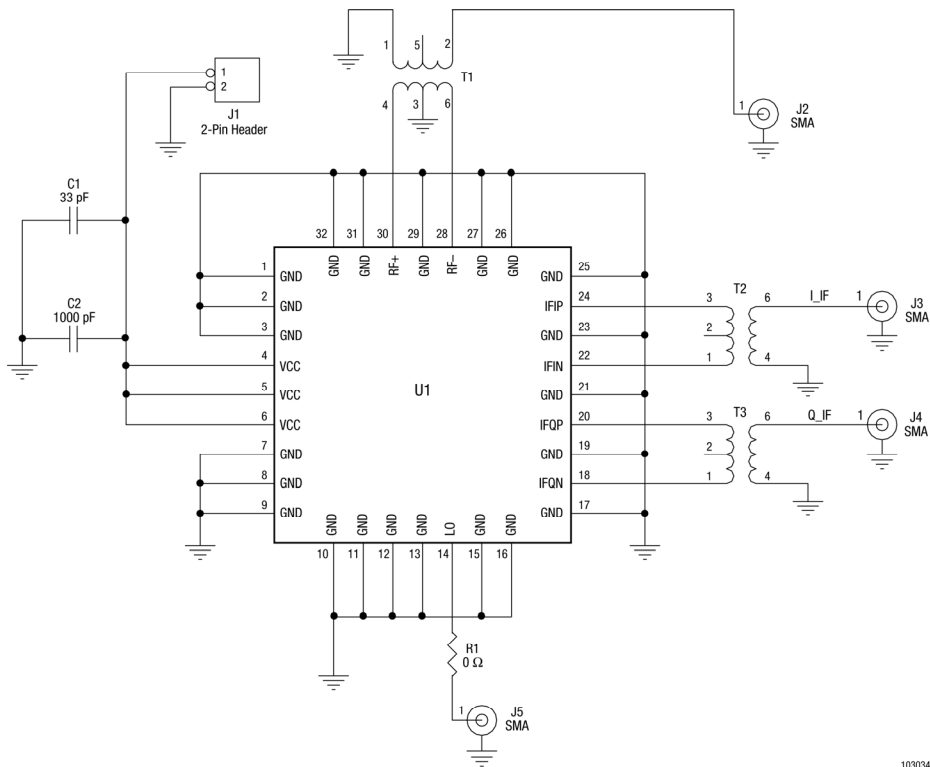

103034-005

Figure 5. SKY73009-11 Evaluation Board Schematic (800 to 1000 MHz)

Table 5. SKY73009-11 Evaluation Board Component Values (800 to 1000 MHz)

Component	Value	Manufacturer
C1	33 pF (0603)	Any
C2	1000 pF (0603)	Any
R1	0 Ω (0603)	Any
T1	1:1 (800 to 1000 MHz)	Murata LDB31900M05C-417
PCB	TW11-D982	Skyworks

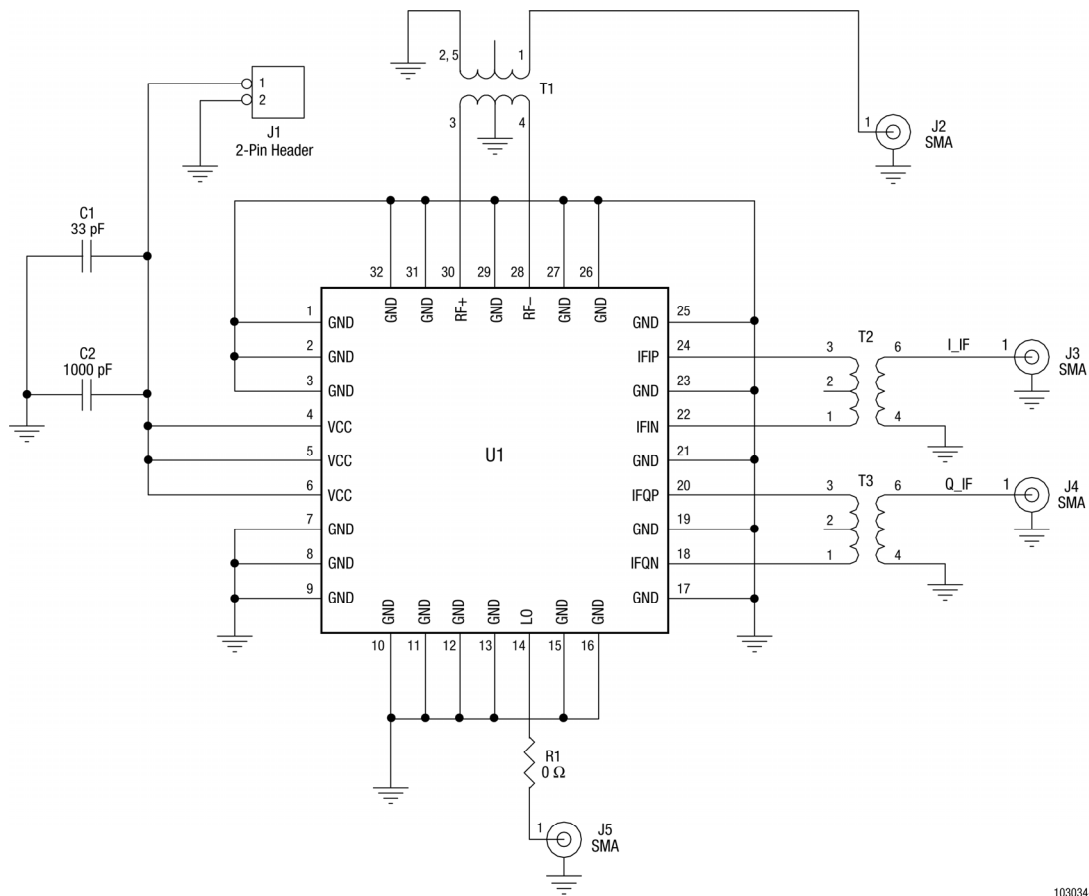

103034-006

Figure 6. SKY73009-11 Evaluation Board Schematic (1500 to 2500 MHz)

Table 6. SKY73009-11 Evaluation Board Component Values (1500 to 2500 MHz)

Component	Value	Manufacturer
C1	33 pF (0603)	Any
C2	1000 pF (0603)	Any
R1	0 Ω (0603)	Any
T1	1:1 (1500 to 2500 MHz)	Murata LDB31900M05C-417
PCB	TW11-D992	Skyworks

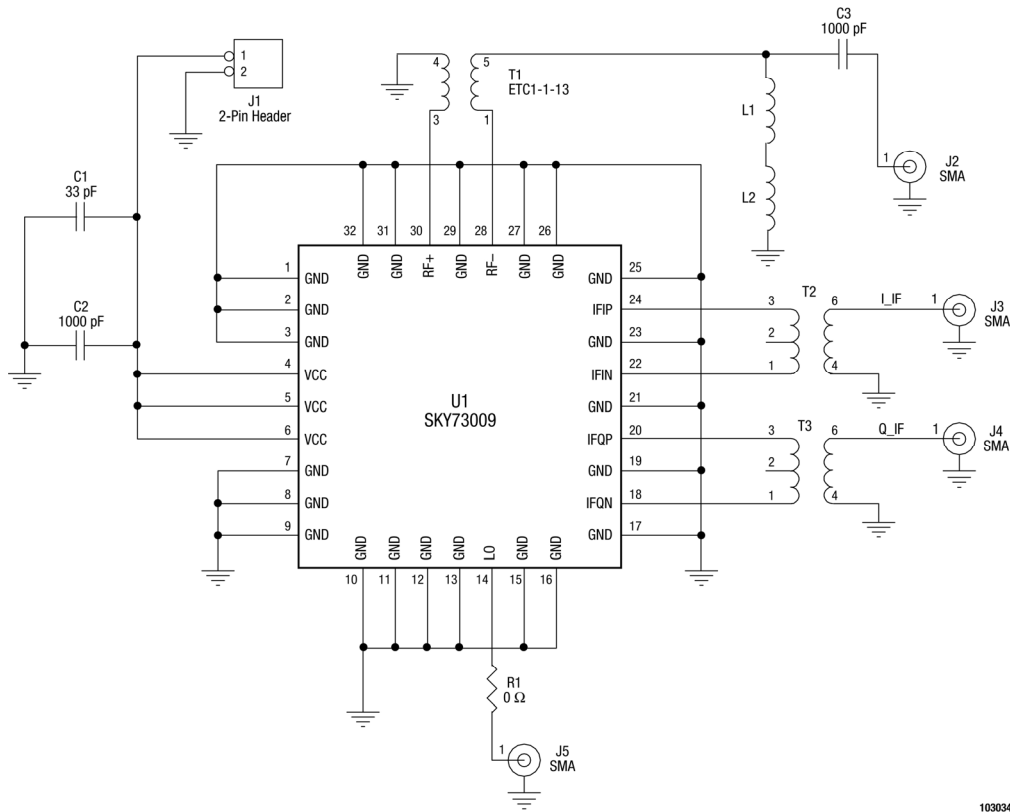
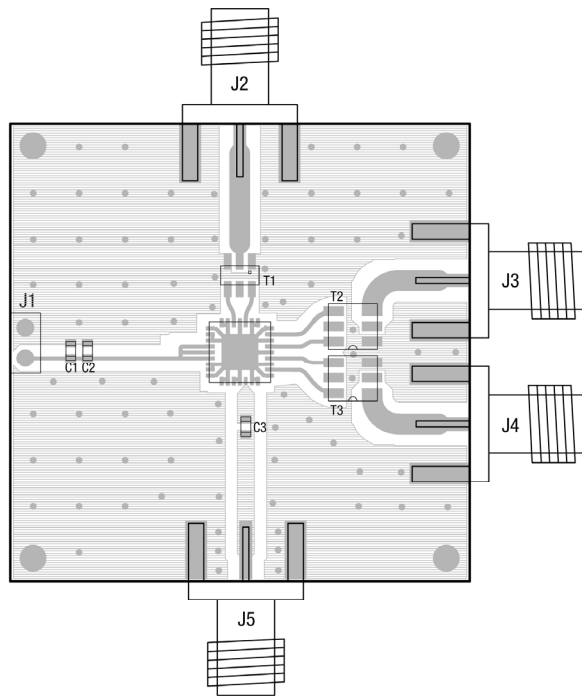

Figure 7. SKY73009-11 Evaluation Board Schematic (Custom Frequency)

103034-007

Table 7. SKY73009-11 Evaluation Board Component Values (Custom Frequency)

Component	Value	Manufacturer
C1	33 pF (0603)	Any
C2	1000 pF (0603)	Any
C3	33 pF (0603)	Any
L1	Adjusted for best match at desired frequency	
L2	Adjusted for best match at desired frequency	
R1	0 Ω (0603)	Any
T1	1:1 (4.5 to 3000 MHz)	M/A-Com
T2	9:1	Mini-Circuits
T3	9:1	Mini-Circuits
PCB	TW12-D275	Skyworks



Component Placement

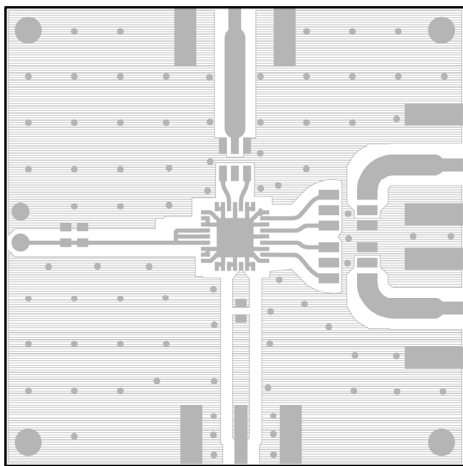

Top Layer

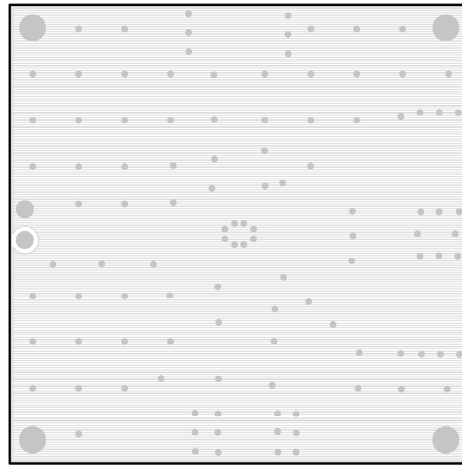

Bottom Layer

103034-008

Figure 8. SKY73009-11 Evaluation Board Assembly Diagram - 800 to 1000 MHz

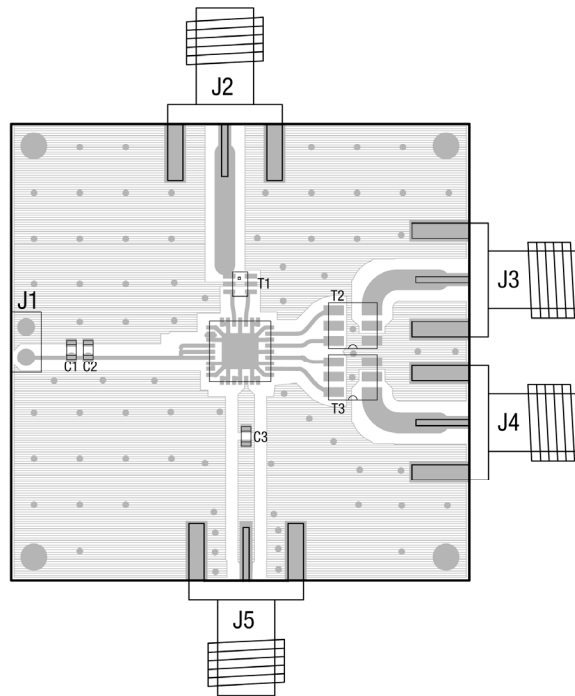

Component Placement

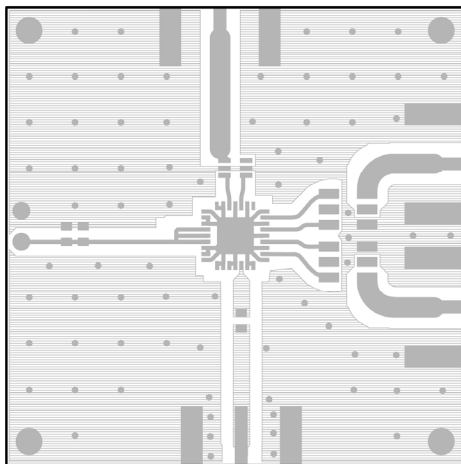

Top Layer

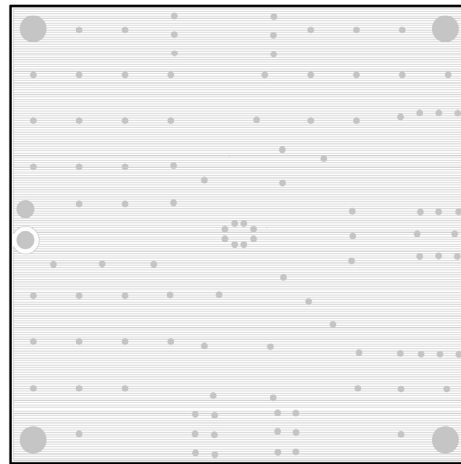

Bottom Layer

103034-009

**Figure 9. SKY73009-11 Evaluation Board Assembly Diagram - 1500 to 2500 MHz**

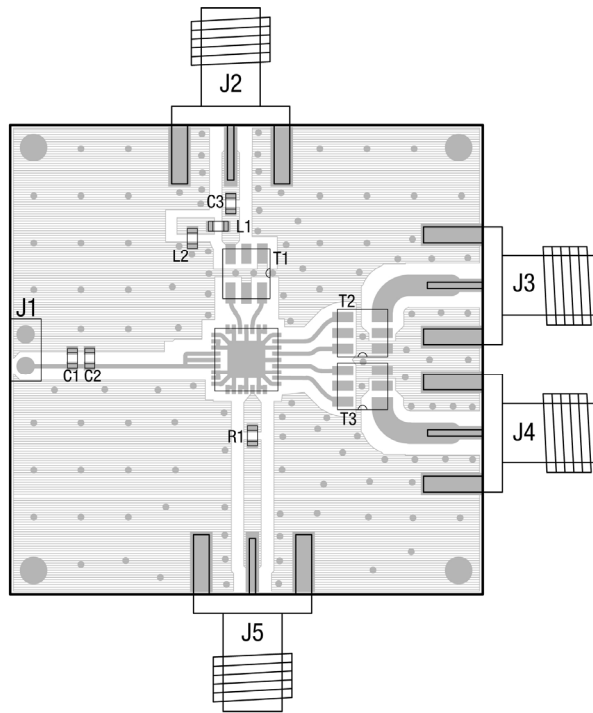

Component Placement

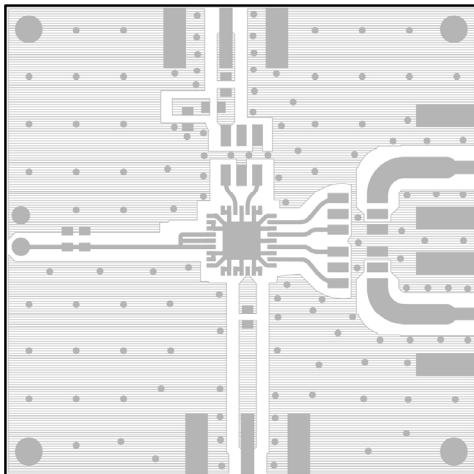

Top Layer

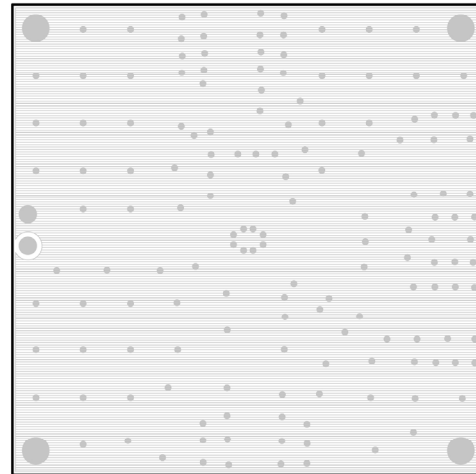

Bottom Layer

103034-010

Figure 10. SKY73009-11 Evaluation Board Assembly Diagram - Custom Frequency

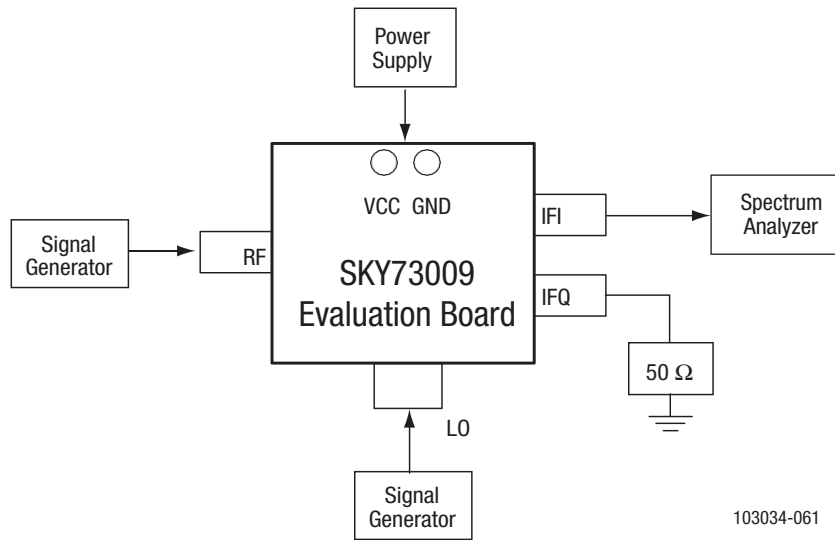

103034-061

**Figure 11. SKY73009-11 Evaluation Board Testing Configuration**

## Package Dimensions

Package dimensions are shown in Figure 12, and tape and reel dimensions are provided in Figure 13.

## Package and Handling Information

Since the device package is sensitive to moisture absorption, it is baked and vacuum packed before shipping. Instructions on the shipping container label regarding exposure to moisture after the container seal is broken must be followed. Otherwise, problems related to moisture absorption may occur when the part is subjected to high temperature during solder assembly.

The SKY73009-11 is rated to Moisture Sensitivity Level 3 (MSL3) at 260 °C. It can be used for lead or lead-free soldering. For additional information, refer to the Skyworks Application Note, *PCB Design & SMT Assembly/Rework Guidelines for RFLGA Packages*, document number 103147.

Care must be taken when attaching this product, whether it is done manually or in a production solder reflow environment. Production quantities of this product are shipped in a standard tape and reel format.

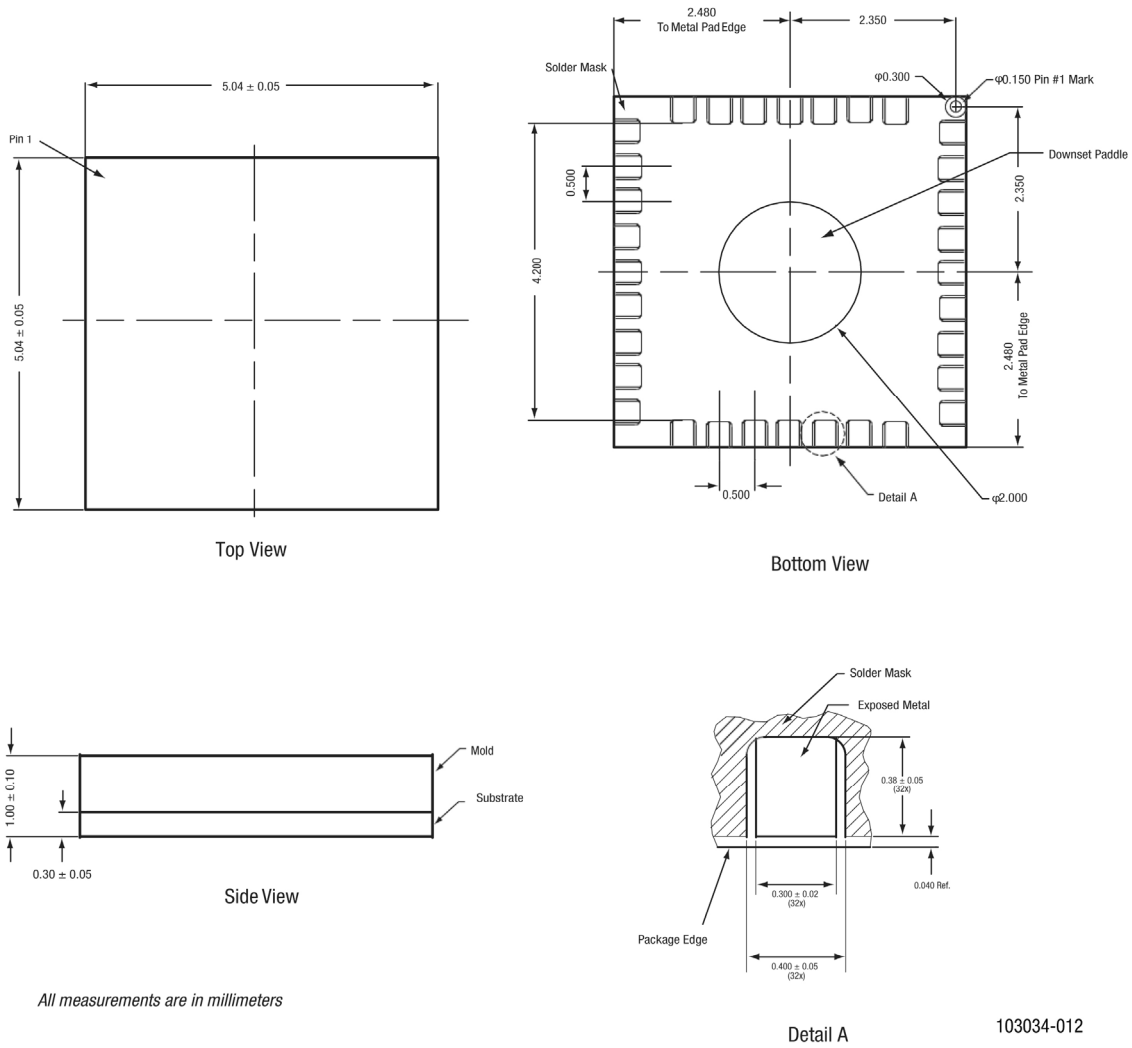

103034-012

Figure 12. SKY73009-11 Package Dimensions

**DATA SHEET • SKY73009-11: 400 TO 3000 MHz DIRECT QUADRATURE DEMODULATOR**

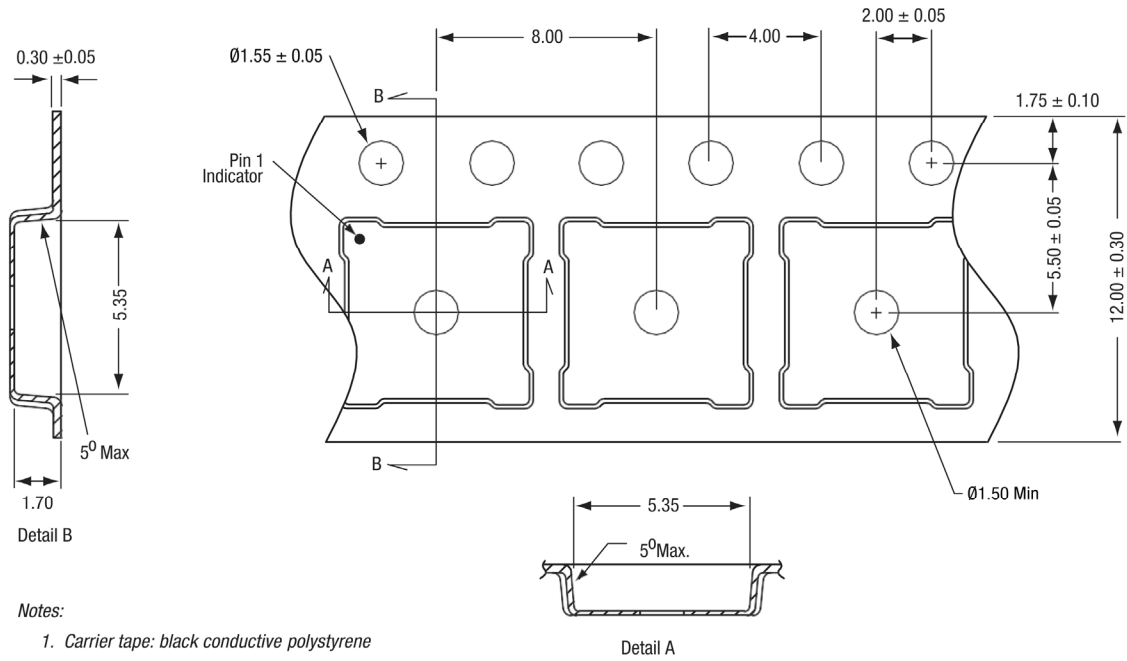

**Notes:**

1. Carrier tape: black conductive polystyrene
2. Cover tape material: transparent conductive PSA
3. Cover tape size: 9.3 mm width
4. All dimensions are in millimeters

103034-013

**Figure 13. SKY73009-11 Tape and Reel Dimensions**

**Ordering Information**

Part Number	Product Description	Evaluation Board Part Number
SKY73009-11	400 to 3000 MHz Direct Quadrature Modulator	SKY73009-11EK1 (tuned for 800 to 1000 MHz) SKY73009-11EK2 (tuned for 1500 to 2500 MHz) SKY73009-11EK3 (custom frequency board)

Copyright © 2003-2006, 2017-2019 Skyworks Solutions, Inc. All Rights Reserved.

Information in this document is provided in connection with Skyworks Solutions, Inc. (“Skyworks”) products or services. These materials, including the information contained herein, are provided by Skyworks as a service to its customers and may be used for informational purposes only by the customer. Skyworks assumes no responsibility for errors or omissions in these materials or the information contained herein. Skyworks may change its documentation, products, services, specifications or product descriptions at any time, without notice. Skyworks makes no commitment to update the materials or information and shall have no responsibility whatsoever for conflicts, incompatibilities, or other difficulties arising from any future changes.

No license, whether express, implied, by estoppel or otherwise, is granted to any intellectual property rights by this document. Skyworks assumes no liability for any materials, products or information provided hereunder, including the sale, distribution, reproduction or use of Skyworks products, information or materials, except as may be provided in Skyworks Terms and Conditions of Sale.

THE MATERIALS, PRODUCTS AND INFORMATION ARE PROVIDED “AS IS” WITHOUT WARRANTY OF ANY KIND, WHETHER EXPRESS, IMPLIED, STATUTORY, OR OTHERWISE, INCLUDING FITNESS FOR A PARTICULAR PURPOSE OR USE, MERCHANTABILITY, PERFORMANCE, QUALITY OR NON-INFRINGEMENT OF ANY INTELLECTUAL PROPERTY RIGHT; ALL SUCH WARRANTIES ARE HEREBY EXPRESSLY DISCLAIMED. SKYWORKS DOES NOT WARRANT THE ACCURACY OR COMPLETENESS OF THE INFORMATION, TEXT, GRAPHICS OR OTHER ITEMS CONTAINED WITHIN THESE MATERIALS. SKYWORKS SHALL NOT BE LIABLE FOR ANY DAMAGES, INCLUDING BUT NOT LIMITED TO ANY SPECIAL, INDIRECT, INCIDENTAL, STATUTORY, OR CONSEQUENTIAL DAMAGES, INCLUDING WITHOUT LIMITATION, LOST REVENUES OR LOST PROFITS THAT MAY RESULT FROM THE USE OF THE MATERIALS OR INFORMATION, WHETHER OR NOT THE RECIPIENT OF MATERIALS HAS BEEN ADVISED OF THE POSSIBILITY OF SUCH DAMAGE.

Skyworks products are not intended for use in medical, lifesaving or life-sustaining applications, or other equipment in which the failure of the Skyworks products could lead to personal injury, death, physical or environmental damage. Skyworks customers using or selling Skyworks products for use in such applications do so at their own risk and agree to fully indemnify Skyworks for any damages resulting from such improper use or sale.

Customers are responsible for their products and applications using Skyworks products, which may deviate from published specifications as a result of design defects, errors, or operation of products outside of published parameters or design specifications. Customers should include design and operating safeguards to minimize these and other risks. Skyworks assumes no liability for applications assistance, customer product design, or damage to any equipment resulting from the use of Skyworks products outside of stated published specifications or parameters.

Skyworks and the Skyworks symbol are trademarks or registered trademarks of Skyworks Solutions, Inc. or its subsidiaries in the United States and other countries. Third-party brands and names are for identification purposes only, and are the property of their respective owners. Additional information, including relevant terms and conditions, posted at [www.skyworksinc.com](http://www.skyworksinc.com), are incorporated by reference.