

DATA SHEET

SKY66420-11: 860 to 930 MHz RF Front-End Module

Applications

- LP-WAN devices
- Internet of Things
- Smart meters
- Industrial applications
- Range extender

Features

- Integrated PA with +27 dBm output power
- Integrated LNA with noise figure of 1.5 dB, typical
- Alternate TX input pin simplifies connection to any SoC
- Transmit bypass path with low loss: < 1.5 dB
- Single-ended 50 Ω transmit/receive RF interface
- Fast turn-on/turn-off time: <4 μs Rx mode and <2 μs Tx mode
- Low-gain power amplifier
- Supply voltage: 2.0 to 4.8 V
- Sleep mode current: < 1 μA
- MCM (16-pin, 3.0 x 3.0 x 0.75 mm) NiPdAu plated package (MSL3, 260 °C per JEDEC J-STD-020)



Skyworks Green™ products are compliant with all applicable legislation and are halogen-free. For additional information, refer to Skyworks Definition of Green™, document number SQ04-0074.

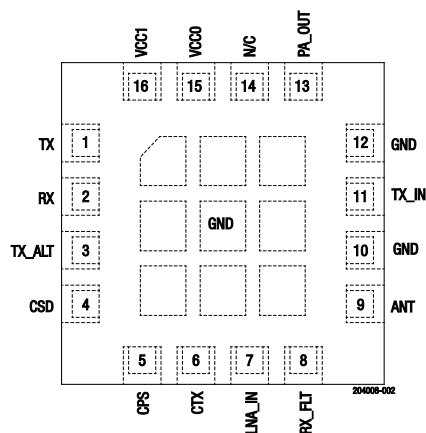

Figure 2. SKY66420-11 Pinout (Top View)

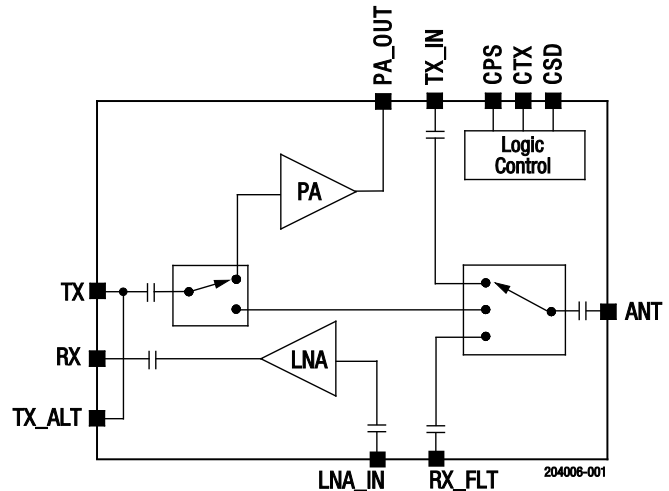

Figure 1. SKY66420-11 Block Diagram

Description

The SKY66420-11 is a high-performance, highly integrated RF front-end module designed for high-power Industrial, Scientific, Medical (ISM) band applications operating in the 860 to 930 MHz frequency range.

The SKY66420-11 is designed for ease of use and maximum flexibility with fully matched 50 Ω TX (or TX_ALT) and RX inputs and antenna outputs, and digital controls compatible with 1.6 to 3.6 V CMOS levels.

The RF blocks operate over a wide supply voltage range from 2.0 to 4.8 V allowing the SKY66420-11 to be used in battery powered applications over a wide spectrum of the battery discharge curve.

The SKY66420-11 is packaged in a 16-pin, 3.0 x 3.0 x 0.75 mm Multi-Chip Module (MCM) package.

A functional block diagram of the SKY66420-11 is provided in Figure 1. Figure 2 shows the pinout for the SKY66420-11. Table 1 lists the pin assignments and signal descriptions.

Table 1. SKY66420-11 Signal Descriptions

Pin	Name	Description	Pin	Name	Description
1	TX	Transmit mode RF input	10	GND	Connect to PCB ground
2	RX	Receive mode RF output	11	TX_IN	TX input signal to antenna (from OMN)
3	TX_ALT	Transmit mode RF input (alternate pin)	12	GND	Connect to PCB ground
4	CSD	Shutdown control input	13	PA_OUT	PA output and positive power supply
5	CPS	Bypass mode select input	14	N/C	Not connected internally to the device
6	CTX	Transmit mode select input	15	VCC0	Positive power supply
7	LNA_IN	LNA input (from RX filter)	16	VCC1	Positive power supply
8	RX_FLT	RX signal from antenna (to RX filter)	Paddle	GND	Exposed die paddle; electrical and thermal ground. Connect to PCB ground
9	ANT	Connect to 50 Ω antenna filter			

Electrical and Mechanical Specifications

Table 2 provides the absolute maximum ratings, and Table 3 shows the recommended operating conditions. Electrical specifications are provided in Tables 4 through 6.

The state of the SKY66420-11 is determined by the control logic shown in Tables 7 and 8. Typical performance characteristics are shown in Figures 3 through 10.

Table 2. SKY66420-11 Absolute Maximum Ratings¹

Parameter	Symbol	Minimum	Maximum	Units
Supply voltage on VCC0 (no RF)	V _{CC0}	-0.3	+5.5	V
Supply voltage on VCC1 and PA_OUT (no RF)	V _{CC}	-0.3	+5.5	V
Operating temperature	T _A	-40	+85	°C
Storage temperature	T _{STG}	-40	+125	°C
Tx input power at TX port	P _{IN_TX_MAX}		+17	dBm
TX input power at TX port (bypass mode)	P _{IN_TX_BYP_MAX}		+20	dBm
Rx input power at ANT port	P _{IN_RX_MAX}		+10	dBm
Electrostatic discharge: Human Body Model (HBM), Class 1C	ESD		1000	V

¹ Exposure to maximum rating conditions for extended periods may reduce device reliability. There is no damage to device with only one parameter set at the limit and all other parameters set at or below their nominal value. Exceeding any of the limits listed here may result in permanent damage to the device.

ESD HANDLING: *Although this device is designed to be as robust as possible, electrostatic discharge (ESD) can damage this device. This device must be protected at all times from ESD when handling or transporting. Static charges may easily produce potentials of several kilovolts on the human body or equipment, which can discharge without detection. Industry-standard ESD handling precautions should be used at all times.*

Table 3. SKY66420-11 Recommended Operating Conditions

Parameter	Symbol	Min	Typ	Max	Units
Supply voltage on VCC0	VCC0	2.0	3.3	4.8	V
Supply voltage on VCC1 and PA_OUT	VCC	2.0	3.3	4.8	V
Ambient temperature	TA	-40	+25	+85	°C

Table 4. SKY66420-11 DC Electrical Specifications¹
(VCC0 = VCC1 = 3.3 V, f = 915 MHz, TA = +25 °C, Unless Otherwise Noted)

Parameter	Symbol	Test Condition	Min	Typ	Max	Units
Total supply current, transmit mode	ICC_TX27	POUT = +27 dBm		280		mA
Total supply current, receive mode	ICC_RX	No RF		5		mA
Total supply current, transmit bypass mode	ICC_TXB	No RF		200		µA
Quiescent current	ICQ_TX	No RF		50		mA
Sleep supply current	ICC_OFF	No RF			1.00	µA

¹ Performance is guaranteed only under the conditions listed in this table.

Table 5. SKY66420-11 AC Electrical Specifications: Transmit Mode
(VCC0 = VCC1 = 3.3 V, TA = +25 °C, All Unused Ports Terminated at 50 Ω, Unless Otherwise Noted. Input Port TX, Output Port ANT, Matching Network Connected between the PA_OUT and TX_IN)

Parameter	Symbol	Test Condition	Min	Typ	Max	Units
Frequency range	f		860		930	MHz
Output power at ANT ^{1,2}	POUT_915	f = 915 MHz		+27		dBm
	POUT_868	f = 868 MHz		+27		dBm
Small signal gain ^{1,2}	S21_915	f = 915 MHz		16		dB
	S21_868	f = 868 MHz		16		dB
Small signal gain variation ^{1,2}	ΔS21	Peak to peak gain variation across frequency band			1	dB
Input return loss ^{1,2}	S11	Into 50 Ω (TX port)		-10		dB
Output return loss ^{1,2}	S22	Into 50 Ω (ANT port)		-10		dB
Input 1 dB compression point, bypass mode	BYP_IP1dB	Bypass mode	+20			dBm
2 nd harmonic ³	2fo	POUT = +27 dBm			+7	dBm
3 rd to 10 th harmonic ³	3fo to 10fo	POUT = +27 dBm			-42	dBm
Insertion loss (bypass mode)	S21_BYP	TX to ANT			1.5	dB
Turn-on time ⁴	ton			1	2	µs
Turn-off time ⁵	toff				1	µs
Stability	STAB	CW, PIN = +16 dBm 0.1 GHz to 20 GHz load VSWR = 6:1	All non-harmonically related outputs less than -42 dBm			
Ruggedness	RU	CW, POUT = +27 dBm into 50 Ω, load VSWR = 10:1	No permanent damage			

¹ 900 to 930 MHz with specified matching network on the Evaluation Board.

² 860 to 870 MHz with specified matching network on the Evaluation Board.

³ Measured with continuous wave signal.

⁴ From 50% of CTX edge to 90% of final RF output power.

⁵ From 50% of CTX edge to 10% of initial RF output power.

Table 6. SKY66420-11 AC Electrical Specifications: Receive Mode

(V_{CC0} = V_{CC1} = 3.3 V, T_A = +25 °C, All Unused Ports Terminated at 50 Ω, Unless Otherwise Noted. Input Port ANT, Output Port RX, 0 Ω Connected between RX_FLT and LNA_IN)

Parameter	Symbol	Test Condition	Min	Typical	Max	Units
Frequency range	f _{IN}		860		930	MHz
Receive gain	RX_GAIN			18		dB
Receive noise figure	NF			1.5	2.5	dB
Input third order intercept	IIP3		-6.5	-2		dBm
Input 1-dB compression point	IP1dB		-16.5	-12		dBm
Antenna port return loss	S11ANT	Into 50 Ω (ANT port)		-12		dB
RX port return loss	S22RX	Into 50 Ω (RX port)		-12		dB
Turn-on time ¹	t _{ON}			2.5		μs
Turn-off time ²	t _{OFF}				1	μs

¹ From 50% of CTX edge to 90% of final RF output power.

² From 50% of CTX edge to 10% of initial RF output power.

Table 7. SKY66420-11 Electrical Specifications: Control Logic Characteristics¹

(T_A = +25 °C, Unless Otherwise Noted)

Parameter	Symbol	Test Condition	Min	Typical	Max	Units
Control voltage:						
High	V _{IH}		1.6 ²		V _{CC0}	V
Low	V _{IL}		0		0.3 ²	V
Input current:						
High	I _{IH}				1	μA
Low	I _{IL}				1	μA

¹ Performance is guaranteed only under the conditions listed in this table.

² Logic inputs must be V_{CC0} or GND to achieve specified sleep currents.

Table 8. SKY66420-11 Electrical Specifications: Mode Control Logic (T_A = +25)

Mode	CSD	CTX	CPS
Shutdown	0	x ¹	x ¹
Receive LNA mode	1	0	x ¹
Transmit bypass	1	1	0
Transmit	1	1	1

¹ X (don't care) inputs must be held at V_{CC0} or GND to achieve specified sleep current.

Typical Performance Characteristics

(Vcc0 = Vcc1 = 3.3 V, f = 915 MHz, Ta = +25 °C, Unless Otherwise Noted)

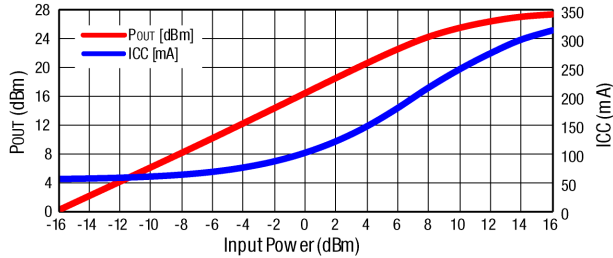

Figure 3. Pout and Icc vs Pin, CW

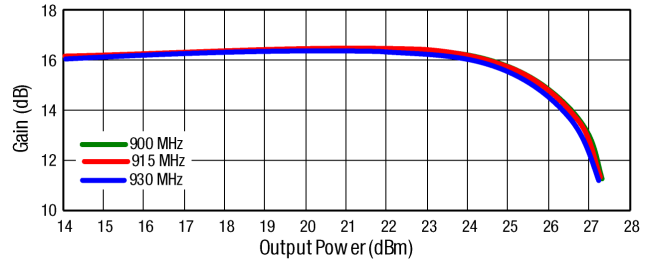

Figure 4. Gain vs Pout, CW

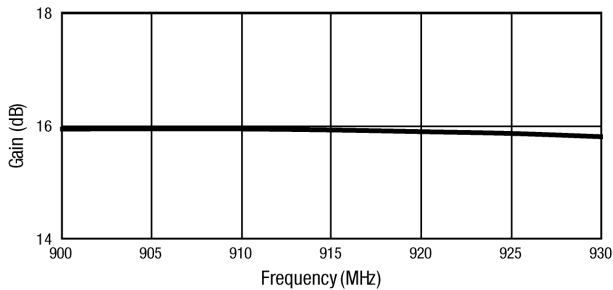

Figure 5. Small Signal Gain vs Frequency, CW

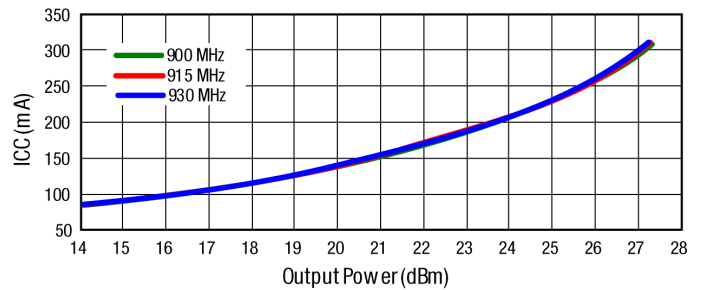

Figure 6. Icc vs Pout, CW

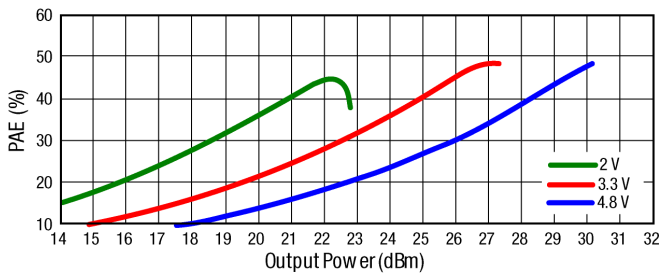

Figure 7. PAE vs Pout and VCC, CW

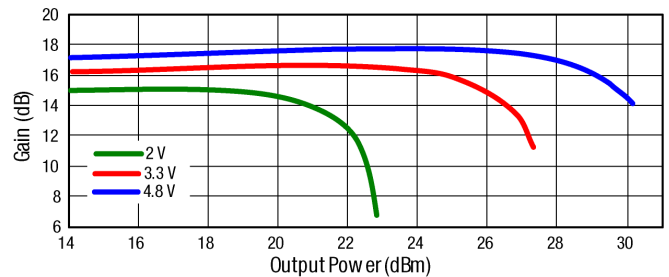

Figure 8. Gain vs Pout and VCC, CW

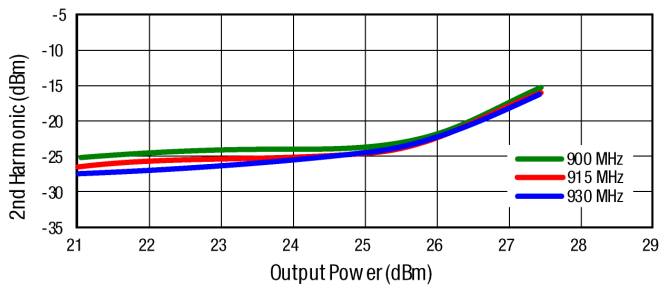

Figure 9. 2nd Harmonic vs Pout, CW

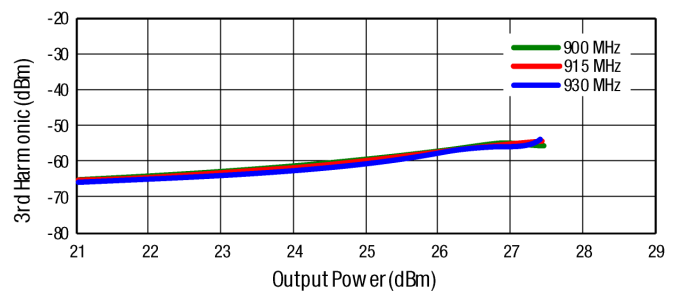

Figure 10. 3rd Harmonic vs Pout, CW

Evaluation Board Description

The SKY66420-11-EK1 Evaluation Board is designed to demonstrate the performance of the SKY66420-11 RF Front-End Module. It is optimized for evaluation, experimentation, and investigation, using CW (continuous wave) signals.

Figure 11 shows the Evaluation Board. The Evaluation Board schematic diagram for 915 MHz application (EK1) is provided in Figure 12. The Bill of Materials (BOM) for the SKY66420-11 Evaluation Board for 915 MHz application (EK1) is listed in Table 9

The Evaluation Board schematic diagram for 868 MHz (EK3) is provided in Figure 13. The Bill of Materials (BOM) for the SKY66420-11 Evaluation Board for 868 MHz (EK3) is listed in Table 10.

PCB Recommendations

Top layer: Plan to add the footprint for a shield case over the RF section.

Bottom layer: Lay out as much as possible for minimum traces on the bottom. Having a solid ground plane under the shield case will complete the shielding.

Avoid using thermal relief pads for ground connections of components and the shield case. Always place vias close to each shunt connection.

Spread ground vias equally in a manner that stitches the grounds together.

Metal Layer 1 = RF traces (microstripes or coplanar) + control lines. Core thickness between top RF layer and ground plane is critical.

Metal Layer 2 = Solid ground plane. No trace routings.

Metal Layer 3 = Control lines + VCC traces (no VCC plane)

Metal Layer 4 = Solid ground plane under the shield case area.

Pour copper on each layer connected to the ground plane. Use VCC traces in a star distribution pattern.

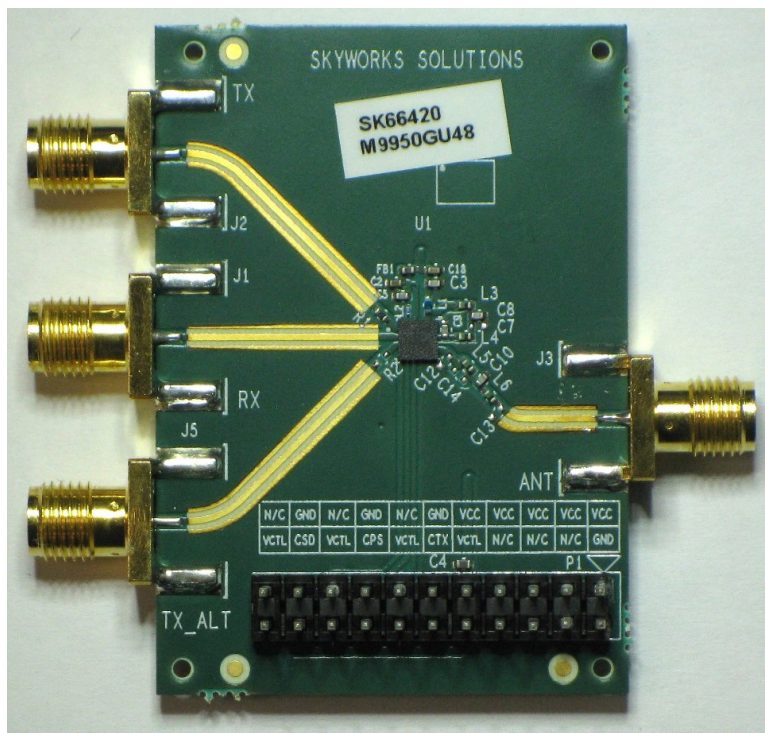

Figure 11. SKY66420-11 Evaluation Board

DATA SHEET • SKY66420-11: 860 TO 930 MHz RF FRONT-END MODULE

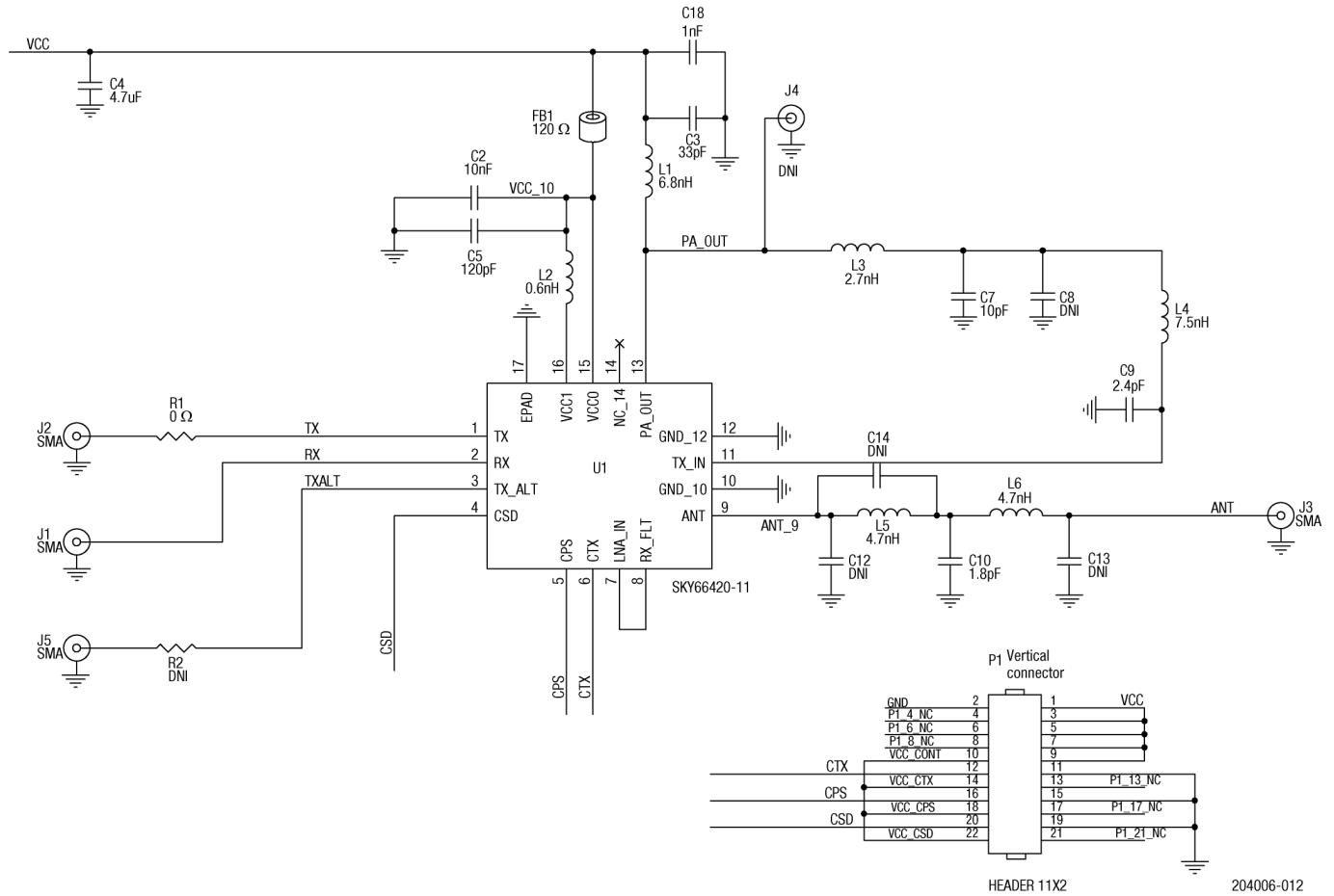

Figure 12. SKY66420-11 Evaluation Board Schematic for 915 MHz Application (EK1)

Table 9. SKY66420-11 Evaluation Board Bill of Materials for 915 MHz Application¹ (EK1)

Component	Value	Manufacturer	Mfr Part Number	Size	Description
C2	10 nF	Murata	GRM155R71H103KA88	0402	Ceramic capacitor 10000 pF 50 V X7R
C3	33 pF	Murata	GRM1555C1H330JA01	0402	Ceramic capacitor 33 pF 50 V COG/NP0
C4	4.7 uF	Murata	GRM155R61A475MEAA	0402	Ceramic capacitor 4.7 uF 10 V X5R
C5	120 pF	Murata	GRM1555C1H121GA01	0402	Ceramic capacitor 120 pF 50 V COG/NP0
C7	10 pF	Murata	GRM1555C1E100JA01D	0402	Ceramic capacitor 10 pF 25 V COG/NP0
R2,C8	DNI			0402	
C9	2.4 pF	Murata	GRM1555C1H2R4CA01	0402	Ceramic capacitor 2.4 pF 50 V COG/NP0
C10	2.2 pF	Murata	GRM1555C1H2R2CA01	0402	Ceramic capacitor 2.2 pF 50 V COG/NP0
C12,C13	DNI	Murata		0402	
C14	DNI				
C18	1 nF	Murata	GRM155R71H102KA01	0402	Ceramic capacitor 1000 pF 50 V X7R
FB1	120 Ω	Taiyo Yuden	BK1005HM121	0402	Ferrite bead 120 Ω 0402 1LN
J1,J2,J3,J5	SMA	Johnson Components	142-0701-851	End launch	Small end launch straight jack receptacle
J4	DNI	Amphenol		Amphenol_132134	Conn SMA jack straight 50 Ω PCB
L1	6.8 nH	Murata	LQW15AN6N8J00D	0402	Fixed inductor 6.8 nH 600 mA 290 MΩ
L2	0.6 nH	Murata	LQP03TN0N8B02D	0201	Fixed inductor 0.6 nH 850 mA 70 MΩ
L3	2.7 nH	Murata	LQG15WZ2N7S02D	0402	Fixed inductor 2.7 nH 900 mA 70 MΩ
L4	7.5 nH	Murata	LQG15HN7N5J02	0402	Fixed inductor 7.5 nH 500 mA 310 MΩ
L5,L6	4.7 nH	Murata	LQG15HN4N7S02	0402	Fixed inductor 4.7 nH 700 mA 230 MΩ
PCB1	Z1185-B2	Skyworks	Z1185-B2		EVB
P1	HEADER 11X2	Molex	10-89-1221	11X2	Header 11x2
R1	0 Ω	Panasonic	ERJ2GE0R00	0402	Res SMD 0 Ω jumper 1/10w 0402
U1	SKY66420-11				

¹ Schematic and BOM have been designed to optimize performance with CW signals, 100% duty cycle.

DATA SHEET • SKY66420-11: 860 TO 930 MHz RF FRONT-END MODULE

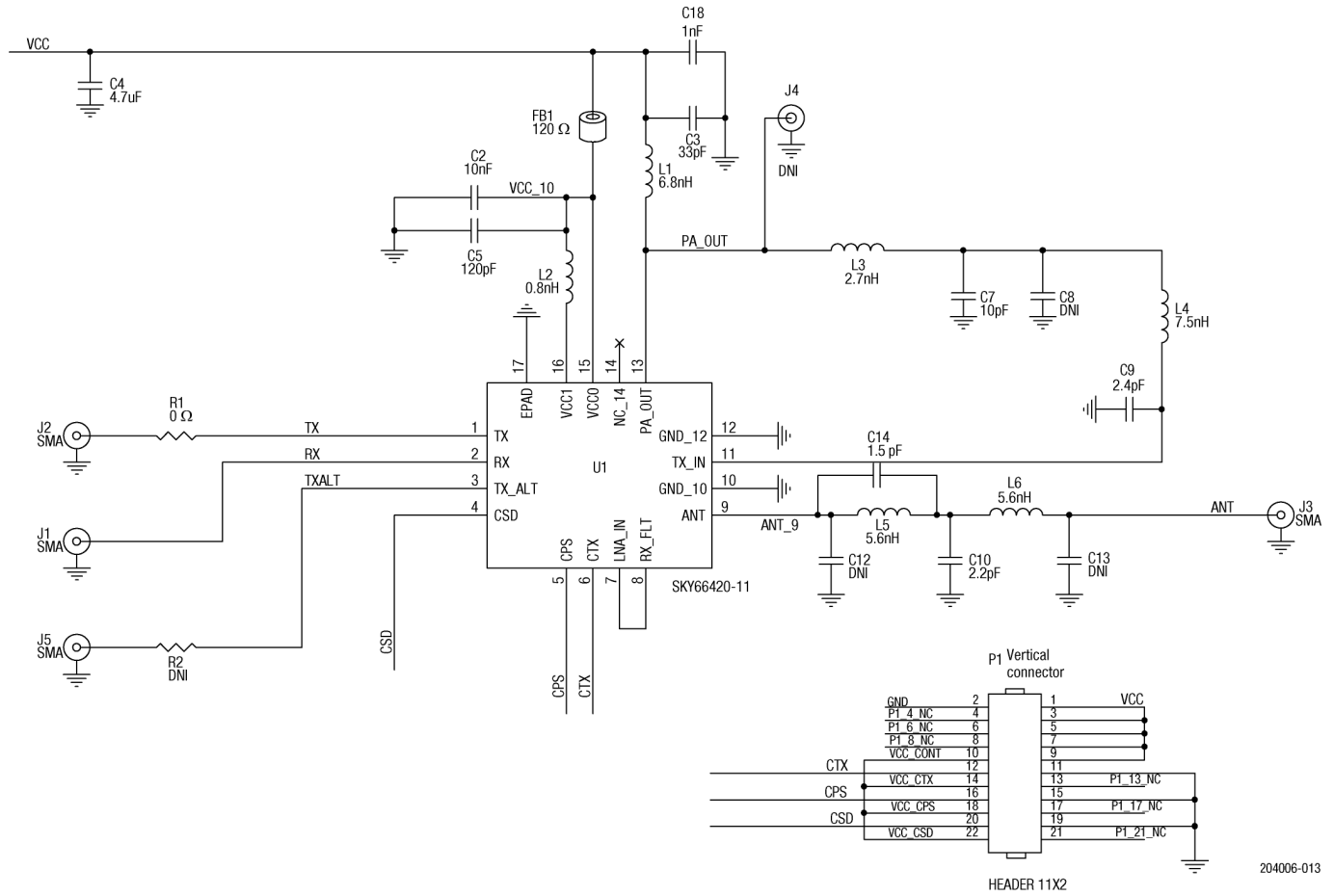

Figure 13. SKY66420-11 Evaluation Board Schematic for 868 MHz Application (EK3)

Table 10. SKY66420-11 Evaluation Board Bill of Materials for 868 MHz Operation¹ (EK3)

Component	Value	Manufacturer	Mfr Part Number	Size	Description
C2	10 nF	Murata	GRM155R71H103KA88	0402	Ceramic capacitor 10000 pF 50 V X7R
C3	33 pF	Murata	GRM1555C1H330JA01	0402	Ceramic capacitor 33 pF 50 V COG/NPO
C4	4.7 uF	Murata	GRM155R61A475MEAA	0402	Ceramic capacitor 4.7uF 10 V X5R
C5	120 pF	Murata	GRM1555C1H121GA01	0402	Ceramic capacitor 120 pF 50 V COG/NPO
R2, C7	DNI		GRM1555C1E100JA01D		
C8	10 pF	Murata		0402	Ceramic capacitor 10 pF 50 V X7R
C9	2.4 pF	Murata	GRM1555C1H2R4CA01	0402	Ceramic capacitor 2.4 pF 50 V COG/NPO
C10	2.2 pF	Murata	GRM1555C1H2R2CA01	0402	Ceramic capacitor 2.2 pF 50 V COG/NPO
C12,C13	DNI	Murata		0402	
C14	1.5 pF	Murata	GRM1555C1H1R5CA01		Ceramic capacitor 1.5 pF 50 V COG/NPO
C18	1 nF	Murata	GRM155R71H102KA01	0402	Ceramic capacitor 1000 pF 50 V X7R
FB1	120 Ω	Taiyo Yuden	BK1005HM121	0402	Ferrite bead 120 Ω 0402 1LN
J1,J2,J3,J5	SMA	Johnson Components	142-0701-851	End launch	Small end launch straight jack receptacle
J4	DNI	Amphenol		Amphenol_132134	Conn SMA jack straight 50 Ω PCB
L1	6.8 nH	Murata	LQW15AN6N8J00D	0402	Fixed inductor 6.8 nH 600 mA 290 MΩ
L2	0.8 nH	Murata	LQP03TN0N8B02D	0201	Fixed inductor 0.8 nH 850 mA 70 MΩ
L3	2.7 nH	Murata	LQG15WZ2N7S02D	0402	Fixed inductor 2.7 nH 800 mA 70 MΩ
L4	7.5 nH	Murata	LQG15HN7N5J02	0402	Fixed inductor 7.5 nH 500 mA 310 MΩ
L5,L6	5.6 nH	Murata	LQG15HN5N6S02D	0402	Fixed inductor 5.6 nH 600 mA 260 MΩ
PCB1	Z1185-B2	Skyworks	Z1185-B2		EVB
P1	HEADER 11X2	Molex	10-89-1221	11X2	Header 11x2
R1	0 Ω	Panasonic	ERJ2GE0R00	0402	Res SMD 0 Ω jumper 1/10w
U1	SKY66420-11				

¹ Schematic and BOM have been designed to optimize performance with CW signals, 100% duty cycle.

Package Dimensions

The layout footprint for the SKY66420-11 is provided in Figure 14. Typical part markings are shown in Figure 15. Package dimensions for the SKY66420-11 are shown in Figure 16, and tape and reel dimensions are provided in Figure 17.

Package and Handling Information

Instructions on the shipping container label regarding exposure to moisture after the container seal is broken must be followed. Otherwise, problems related to moisture absorption may occur when the part is subjected to high temperature during solder assembly.

The SKY66420-11 is rated to Moisture Sensitivity Level 3 (MSL3) at 260 °C. It can be used for lead or lead-free soldering. For additional information, refer to the Skyworks Application Note, *Solder Reflow Information*, document number 200164.

Care must be taken when attaching this product, whether it is done manually or in a production solder reflow environment. Production quantities of this product are shipped in a standard tape and reel format.

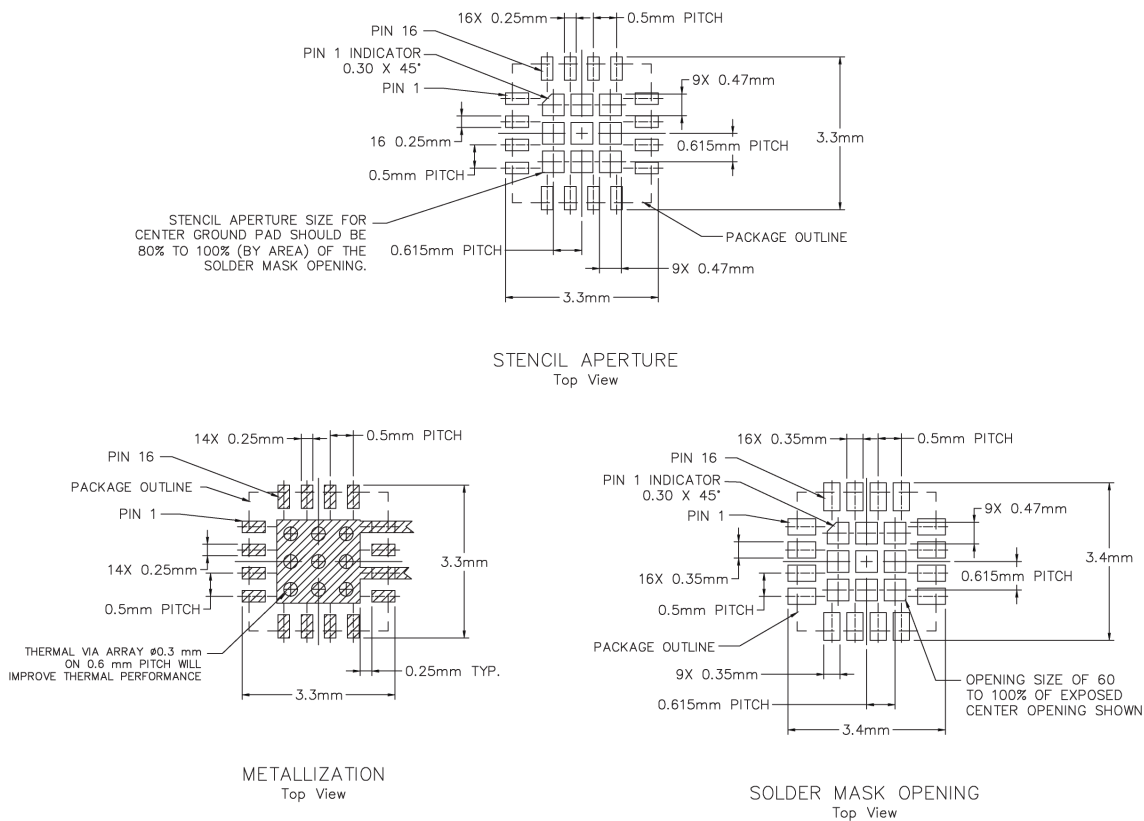

NOTE: THERMAL VIAS SHOULD BE RESIN FILLED AND CAPPED IN ACCORDANCE WITH IPC-4761 TYPE VII VIAS. 30-35UM Cu THICKNESS IS RECOMMENDED.

204006-014

Figure 14. SKY66420-11 Recommended Footprint (Top View)

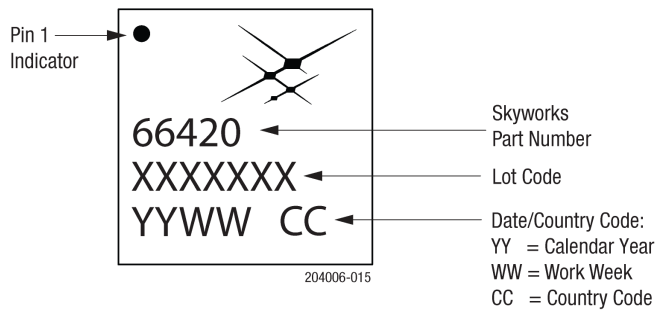
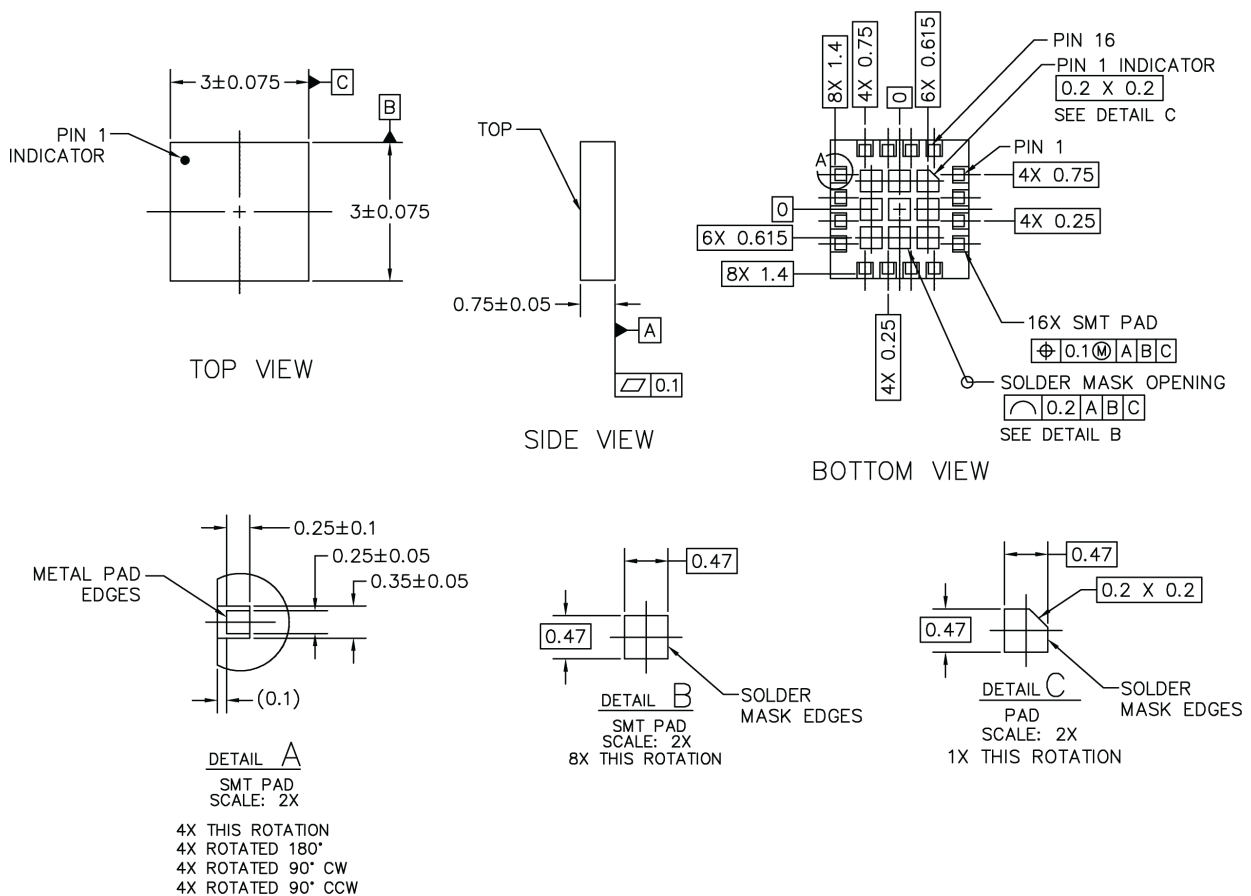

Figure 15. Typical Part Markings (Top View)



NOTES: UNLESS OTHERWISE SPECIFIED.

1. DIMENSIONING AND TOLERANCING IN ACCORDANCE WITH ASME Y14.5M-1994.
2. DIMENSIONS ARE IN MILLIMETERS

204006-016

Figure 16. SKY66420-11 Package Dimensions

DATA SHEET • SKY66420-11: 860 TO 930 MHz RF FRONT-END MODULE

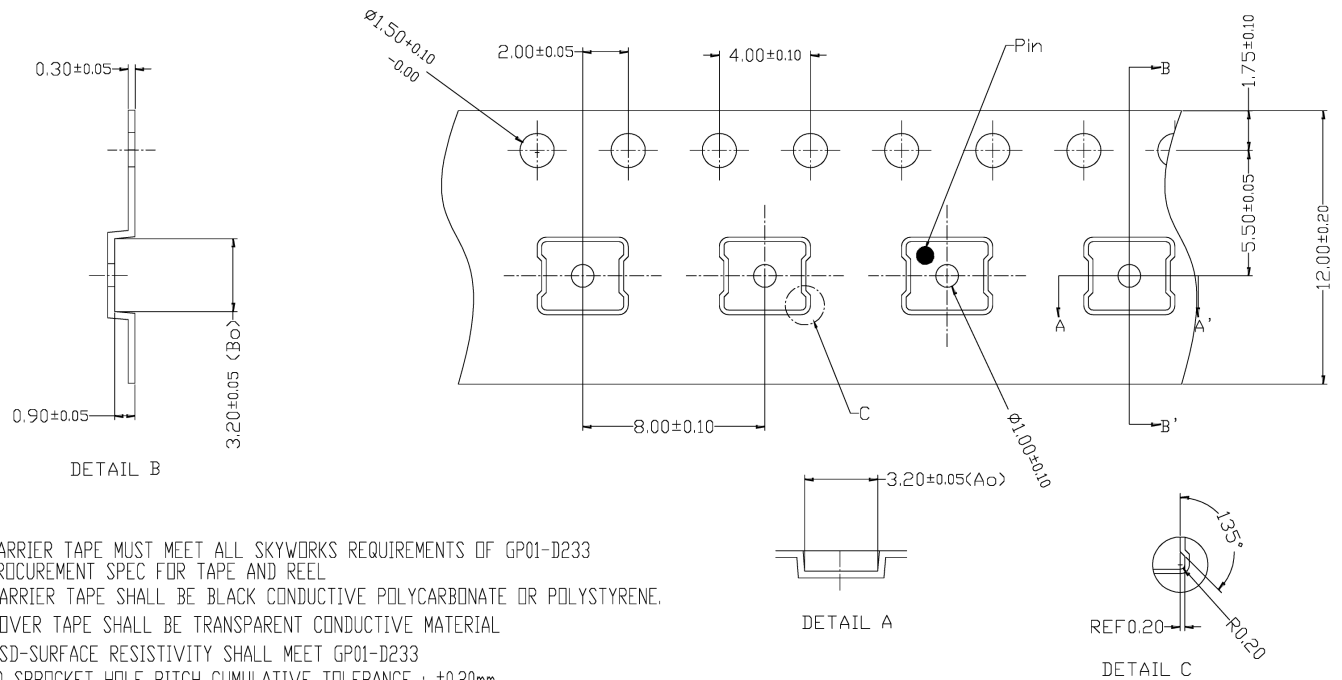

1. CARRIER TAPE MUST MEET ALL SKYWORKS REQUIREMENTS OF GP01-D233 PROCUREMENT SPEC FOR TAPE AND REEL
2. CARRIER TAPE SHALL BE BLACK CONDUCTIVE POLYCARBONATE OR POLYSTYRENE.
3. COVER TAPE SHALL BE TRANSPARENT CONDUCTIVE MATERIAL
4. ESD-SURFACE RESISTIVITY SHALL MEET GP01-D233
5. 10 SPROCKET HOLE PITCH CUMULATIVE TOLERANCE : ±0.20mm
6. Ao & Bo MEASURED ON PLANE 0.30mm ABOVE THE BOTTOM OF THE POCKET.
7. ALL DIMENSIONS ARE IN MILLIMETERS.

Figure 17. SKY66420-11 Tape and Reel Dimensions

204666-017

Ordering Information

Part Number	Product Description	Evaluation Board Part Number
SKY66420-11	RF Front-End Module 915 MHz	SKY66420-11EK1
SKY66420-11	RF Front-End Module 868 MHz	SKY66420-11EK3

Copyright © 2016-2020 Skyworks Solutions, Inc. All Rights Reserved.

Information in this document is provided in connection with Skyworks Solutions, Inc. (“Skyworks”) products or services. These materials, including the information contained herein, are provided by Skyworks as a service to its customers and may be used for informational purposes only by the customer. Skyworks assumes no responsibility for errors or omissions in these materials or the information contained herein. Skyworks may change its documentation, products, services, specifications or product descriptions at any time, without notice. Skyworks makes no commitment to update the materials or information and shall have no responsibility whatsoever for conflicts, incompatibilities, or other difficulties arising from any future changes.

No license, whether express, implied, by estoppel or otherwise, is granted to any intellectual property rights by this document. Skyworks assumes no liability for any materials, products or information provided hereunder, including the sale, distribution, reproduction or use of Skyworks products, information or materials, except as may be provided in Skyworks Terms and Conditions of Sale.

THE MATERIALS, PRODUCTS AND INFORMATION ARE PROVIDED “AS IS” WITHOUT WARRANTY OF ANY KIND, WHETHER EXPRESS, IMPLIED, STATUTORY, OR OTHERWISE, INCLUDING FITNESS FOR A PARTICULAR PURPOSE OR USE, MERCHANTABILITY, PERFORMANCE, QUALITY OR NON-INFRINGEMENT OF ANY INTELLECTUAL PROPERTY RIGHT; ALL SUCH WARRANTIES ARE HEREBY EXPRESSLY DISCLAIMED. SKYWORKS DOES NOT WARRANT THE ACCURACY OR COMPLETENESS OF THE INFORMATION, TEXT, GRAPHICS OR OTHER ITEMS CONTAINED WITHIN THESE MATERIALS. SKYWORKS SHALL NOT BE LIABLE FOR ANY DAMAGES, INCLUDING BUT NOT LIMITED TO ANY SPECIAL, INDIRECT, INCIDENTAL, STATUTORY, OR CONSEQUENTIAL DAMAGES, INCLUDING WITHOUT LIMITATION, LOST REVENUES OR LOST PROFITS THAT MAY RESULT FROM THE USE OF THE MATERIALS OR INFORMATION, WHETHER OR NOT THE RECIPIENT OF MATERIALS HAS BEEN ADVISED OF THE POSSIBILITY OF SUCH DAMAGE.

Skyworks products are not intended for use in medical, lifesaving or life-sustaining applications, or other equipment in which the failure of the Skyworks products could lead to personal injury, death, physical or environmental damage. Skyworks customers using or selling Skyworks products for use in such applications do so at their own risk and agree to fully indemnify Skyworks for any damages resulting from such improper use or sale.

Customers are responsible for their products and applications using Skyworks products, which may deviate from published specifications as a result of design defects, errors, or operation of products outside of published parameters or design specifications. Customers should include design and operating safeguards to minimize these and other risks. Skyworks assumes no liability for applications assistance, customer product design, or damage to any equipment resulting from the use of Skyworks products outside of stated published specifications or parameters.

Skyworks, the Skyworks symbol, Skyworks Green™, and Sky5® are trademarks or registered trademarks of Skyworks Solutions, Inc. or its subsidiaries in the United States and other countries. Third-party brands and names are for identification purposes only, and are the property of their respective owners. Additional information, including relevant terms and conditions, posted at www.skyworksinc.com, are incorporated by reference.