

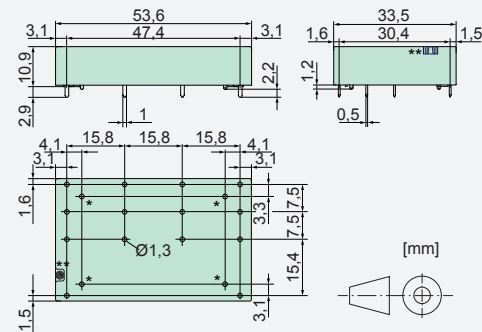

Relay Key Data

- PCB Relay with forcibly guided contacts
- Protective separation between coil and contacts (>5,5 mm) and contacts side by side (>5,5 mm)
- EN50205 type A
- Double and reinforced insulation
- SMD arrangement below relay possible
- Contact mounting: SIF422 4 NO / 2 NC
- Compact height: only 10,9 mm
- Nominal coil power 0,66 W
- Holding coil power 0,20 W
- Coils for railway application (EN50155) on request

Dimensions



- * Do not drill when SMD arrangement
- ** Open breathing hole

Contact Data

Contact material	AgCuNi + 0,2 µm Au
Type of contact	Single contact with notched crown
Rated switching capacity	250 VAC 8 A AC1 2000 VA
Electr. life AC 1(360 cycles / h)	approx. 100000
Inrush current max.	30 A for 20 ms
Switching voltage range	5 to 250 VDC / VAC
Switching current range*	3 mA to 8 A
Switching capacity range*	40 mW to 2000 W(VA)
Contact resistance (as delivered)	≤100 mΩ / 6 V / 100 mA

*Guided values

Standard coils for direct current

(other voltages on request)

Nominal voltage VDC	Min. pick-up voltage at 20 °C	Drop-out voltage at 20 °C	Nominal current in mA	Resistance in Ohm at 20 °C
5	≤3,5	≥0,5	133,3	37,5 ± 10%
12	≤8,4	≥1,2	55,8	215 ± 10%
18	≤12,6	≥1,8	38,9	490 ± 10%
20	≤14,0	≥2,0	33,3	600 ± 10%
24	≤16,8	≥2,4	27,5	870 ± 10%
48	≤33,6	≥4,8	13,8	3460 ± 10%
60	≤42,0	≥6,0	11,1	5400 ± 13%
110	≤77,0	≥11,0	6,0	18300 ± 15%

Circuit Diagram (view on relay upper side)

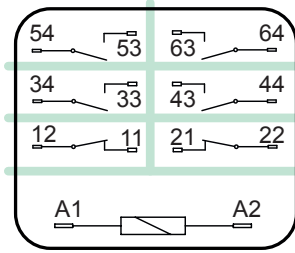

SIF422

Insulation Data

- Double or reinforced insulation	at 250 VAC
- Air and creepage distance	>5,5 mm
- Test voltage	4000 V / 50 Hz / 1 min
Test voltage contact oopen	1500 V / 50 Hz / 1 min
Creepage resistance	CTI 175
Pollution degree	2
Overvoltage category	III
Insulation resistance at Up 500 VDC	>100 MΩ

Additional Data

Mechanical endurance	>10 x 10 ⁶ operations
Switching frequency, mechanical	15 Hz
Response time (all NO closed)	typically 20 ms
Drop-out time** (all NC closed)	typically 8 ms
Bounce time of NO contact	typically 1,5 ms
Bounce time of NC contact	typically 15 ms
Shock resistance 16 ms	NO > 10g NC > 6g
Vibration resistance (10-200 Hz)	NO > 10g NC > 2g
Resistance to short circuiting NO	1000 A SCPD 10 A gG / gL (pre-fuse)
Resistance to short circuiting NC	1000 A SCPD 6 A gG / gL (pre-fuse)
Ambient temperature	-40°C to +70°C
Thermal Resistance	47 K / W
Temperature limit for coil	120°C
Weight	ca. 35 g
Mounting position	any
Type of protection	RT II
Solder bath temperature	270°C / 5 s

**without spark suppression

Tests, Regulations

Approvals



UL File E188953	Sec. 6
Insulation class IEC 60664-1	250 VAC
Fire protection requirements	UL 94 / V0

Options, Accessories

none available

Product Key

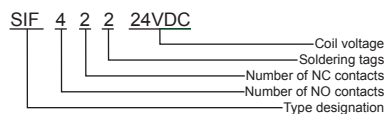

Contact Lifetime for NO Contacts

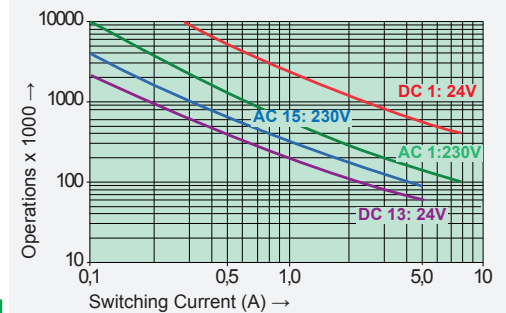

Maximal switching characteristics (DIN EN 60947-5-1)

AC 1:	250 V / 8 A
AC 15:	230 V / 5 A
DC 1:	24 V / 8 A
DC 13:	24 V / 5 A / 0,1 Hz
UL 508:	B300 / R300

Maximal contact load at AC 1 with 230 V:

- 2 contacts with 8 A each
- 3 contacts with 6 A each
- 4 contacts with 4,5 A each

Load Limit Curve with Direct Current

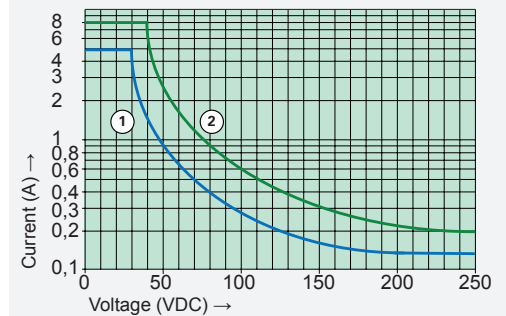

- 1) Inductive load L/R 40 ms
- 2) Resistive load

Excitation Voltage Range

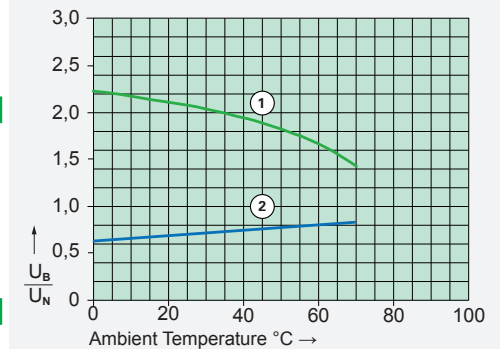

- 1) Max. excitation voltage with contact load: ≤5 A
- 2) Min. excitation voltage (guaranteed values) without previous operation

No heat accumulation due to intrinsic heating of other components. Continuous duty 100%.