

# Si823Hx 数据表

## 具有低传播延迟和高瞬态抗扰度的 4.0 A 对称驱动器 ISODriver

Si823Hx 将两个隔离栅极驱动器组合在单一封装中，适合大功率应用。Si823Hx 包括采用单或双控制输入及独立或高侧/低侧输出的设备。这些驱动器可在 3.0 - 5.5 V 输入 VDD 和最大 30 V 的驱动器电源电压下工作。

Si823Hx 非常适合驱动用于多种开关电源和电机控制应用的功率 MOSFET 和 IGBT。这些驱动器采用 Silicon Labs 自主研发的硅隔离技术，最高支持 1 分钟的 5 kVRMS 隔离电压。这项技术可实现高 CMTI (125 kV/μs)、更低传播延迟和偏移、温度变化和使用寿命过程中变化极低，并且零件匹配更紧密。

独特的输出级体系结构中配有增压设备，可在负载电源开关的米勒平坦区提供更高的上拉能力，以支持更快的开启速度。该驱动器产品系列还提供一些独有的功能，如过热保护、输出欠压锁定 (UVLO) 故障检测、死区时间可编程性，以及默认为低的故障保护驱动器（以应对输入侧断电的情况）。与光耦合栅极驱动器相比，Si823Hx 产品系列可提供更长的使用寿命和明显增强的可靠性。

可以为某些部件编号提供汽车级。这些产品制造过程中的所有步骤均遵循汽车专用流程，能够确保汽车应用所需的稳健性和低缺陷率。

### 工业应用

- 供电系统
- 电机控制系统
- 直流到直流隔离供电
- 照明控制系统
- 太阳能和工业变换器

### 汽车应用

- 车载充电器
- 电池管理系统
- 充电站
- 牵引逆变器
- 混合动力汽车
- 电池动力汽车

### 安全认证

- UL 1577 认证
  - 1 分钟内最大 5000 Vrms
- CSA component notice 5A 认证
  - IEC 60950-1、62368-1 (强化绝缘)
- VDE 认证合规
  - VDE 0884-10 (强化)
  - EN 60950-1、62368-1 (强化绝缘)
- CQC 认证
  - GB4943.1

### 主要特点

- 一个封装中包含一件或两件隔离驱动器
  - 高达 5 kV<sub>RMS</sub> 隔离
  - 高达 1500 V<sub>DC</sub> 峰值驱动器到驱动器差分电压
- 可增强安全性的 EN 引脚，或 DIS 引脚选项
- PWM 和双驱动器版本
- 4.0 A 灌/源峰值输出
- 高电磁抗扰度
- 30 ns 最大传播延迟
- 瞬态抗扰度: >125 kV/μs
- 可编程死区时间: 20 - 200 ns
- 用于噪声滤波的抗尖峰脉冲选项
- 宽泛的温度范围: -40 至 +125 °C
- 符合 RoHS 标准的封装
  - SOIC-14 WB
  - QFN-14
  - SOIC-8
  - SSO-8
  - SOIC-16 NB
- AEC-Q100 认证
- 可提供汽车级 OPN
  - 符合 AIAG 要求的 PPAP 文件支持
  - IMDS 和 CAMDS 列表支持

## 1. Ordering Guide

Table 1.1. Si823Hx Ordering Guide

Ordering Part Number	Configuration	Output UVLO (V)	Enable / Disable	Dead Time Setting (ns)	Deglintch	Delayed Startup Time	Package Type	Isolation Rating (kVrms)
<b>Products Available Now</b>								
Si823H9AC-IS	Single	6	EN	N/A	No	No	SOIC-8	3.75
Si823H9BC-IS	Single	8	EN	N/A	No	No	SOIC-8	3.75
Si823H9CC-IS	Single	12	EN	N/A	No	No	SOIC-8	3.75
Si823H1AB-IS1	HS/LS, VIA/VIB	6	DIS	20 - 200	No	No	SOIC-16 NB	2.5
Si823H1BB-IS1	HS/LS, VIA/VIB	8	DIS	20 - 200	No	No	SOIC-16 NB	2.5
Si823H1CB-IS1	HS/LS, VIA/VIB	12	DIS	20 - 200	No	No	SOIC-16 NB	2.5
Si823H2AB-IS1	HS/LS, VIA/VIB	6	EN	20 - 200	No	No	SOIC-16 NB	2.5
Si823H2BB-IS1	HS/LS, VIA/VIB	8	EN	20 - 200	No	No	SOIC-16 NB	2.5
Si823H2CB-IS1	HS/LS, VIA/VIB	12	EN	20 - 200	No	No	SOIC-16 NB	2.5
Si823H3AB-IS1	HS/LS, VIA/VIB	6	DIS	20 - 200	Yes	No	SOIC-16 NB	2.5
Si823H3BB-IS1	HS/LS, VIA/VIB	8	DIS	20 - 200	Yes	No	SOIC-16 NB	2.5
Si823H3CB-IS1	HS/LS, VIA/VIB	12	DIS	20 - 200	Yes	No	SOIC-16 NB	2.5
Si823H4AB-IS1	HS/LS, PWM	6	EN	20 - 200	No	No	SOIC-16 NB	2.5
Si823H4BB-IS1	HS/LS, PWM	8	EN	20 - 200	No	No	SOIC-16 NB	2.5
Si823H4CB-IS1	HS/LS, PWM	12	EN	20 - 200	No	No	SOIC-16 NB	2.5
Si823H5AB-IS1	Dual, VIA, VIB	6	EN	N/A	No	No	SOIC-16 NB	2.5
Si823H5BB-IS1	Dual, VIA, VIB	8	EN	N/A	No	No	SOIC-16 NB	2.5
Si823H5CB-IS1	Dual, VIA, VIB	12	EN	N/A	No	No	SOIC-16 NB	2.5
Si823H6AB-IS1	Dual, VIA, VIB	6	DIS	N/A	No	No	SOIC-16 NB	2.5
Si823H6BB-IS1	Dual, VIA, VIB	8	DIS	N/A	No	No	SOIC-16 NB	2.5
Si823H6CB-IS1	Dual, VIA, VIB	12	DIS	N/A	No	No	SOIC-16 NB	2.5
Si823H7AB-IS1	Dual, VIA, VIB	6	EN	N/A	No	Yes	SOIC-16 NB	2.5
Si823H7BB-IS1	Dual, VIA, VIB	8	EN	N/A	No	Yes	SOIC-16 NB	2.5
Si823H7CB-IS1	Dual, VIA, VIB	12	EN	N/A	No	Yes	SOIC-16 NB	2.5
Si823H8AB-IS1	HS/LS, PWM	6	DIS	20 - 200	No	No	SOIC-16 NB	2.5
Si823H8BB-IS1	HS/LS, PWM	8	DIS	20 - 200	No	No	SOIC-16 NB	2.5
Si823H8CB-IS1	HS/LS, PWM	12	DIS	20 - 200	No	No	SOIC-16 NB	2.5
Si823H1AB-IM1	HS/LS, VIA/VIB	6	DIS	20 - 200	No	No	QFN-14	2.5
Si823H1BB-IM1	HS/LS, VIA/VIB	8	DIS	20 - 200	No	No	QFN-14	2.5
Si823H1CB-IM1	HS/LS, VIA/VIB	12	DIS	20 - 200	No	No	QFN-14	2.5
Si823H3AB-IM1	HS/LS, VIA/VIB	6	DIS	20 - 200	Yes	No	QFN-14	2.5

Ordering Part Number	Configuration	Output UVLO (V)	Enable / Disable	Dead Time Setting (ns)	Deglitch	Delayed Startup Time	Package Type	Isolation Rating (kVrms)
Si823H3BB-IM1	HS/LS, VIA/VIB	8	DIS	20 - 200	Yes	No	QFN-14	2.5
Si823H3CB-IM1	HS/LS, VIA/VIB	12	DIS	20 - 200	Yes	No	QFN-14	2.5
Si823H5AB-IM1	Dual, VIA, VIB	6	EN	N/A	No	No	QFN-14	2.5
Si823H5BB-IM1	Dual, VIA, VIB	8	EN	N/A	No	No	QFN-14	2.5
Si823H5CB-IM1	Dual, VIA, VIB	12	EN	N/A	No	No	QFN-14	2.5
Si823H6AB-IM1	Dual, VIA, VIB	6	DIS	N/A	No	No	QFN-14	2.5
Si823H6BB-IM1	Dual, VIA, VIB	8	DIS	N/A	No	No	QFN-14	2.5
Si823H6CB-IM1	Dual, VIA, VIB	12	DIS	N/A	No	No	QFN-14	2.5
Si823H8AB-IM1	HS/LS, PWM	6	DIS	20 - 200	No	No	QFN-14	2.5
Si823H8BB-IM1	HS/LS, PWM	8	DIS	20 - 200	No	No	QFN-14	2.5
Si823H8CB-IM1	HS/LS, PWM	12	DIS	20 - 200	No	No	QFN-14	2.5
<b>Contact Silicon Labs for Product Options Below</b>								
Si823H9AD-IS4	Single	6	EN	N/A	No	No	SSO-8	5
Si823H9BD-IS4	Single	8	EN	N/A	No	No	SSO-8	5
Si823H9CD-IS4	Single	12	EN	N/A	No	No	SSO-8	5
Si823H1AD-IS3	HS/LS, VIA/VIB	6	DIS	20 - 200	No	No	SOIC-14 WB	5
Si823H1BD-IS3	HS/LS, VIA/VIB	8	DIS	20 - 200	No	No	SOIC-14 WB	5
Si823H1CD-IS3	HS/LS, VIA/VIB	12	DIS	20 - 200	No	No	SOIC-14 WB	5
Si823H2AD-IS3	HS/LS, VIA/VIB	6	EN	20 - 200	No	No	SOIC-14 WB	5
Si823H2BD-IS3	HS/LS, VIA/VIB	8	EN	20 - 200	No	No	SOIC-14 WB	5
Si823H2CD-IS3	HS/LS, VIA/VIB	12	EN	20 - 200	No	No	SOIC-14 WB	5
Si823H3AD-IS3	HS/LS, VIA/VIB	6	DIS	20 - 200	Yes	No	SOIC-14 WB	5
Si823H3BD-IS3	HS/LS, VIA/VIB	8	DIS	20 - 200	Yes	No	SOIC-14 WB	5
Si823H3CD-IS3	HS/LS, VIA/VIB	12	DIS	20 - 200	Yes	No	SOIC-14 WB	5
Si823H4AD-IS3	HS/LS, PWM	6	EN	20 - 200	No	No	SOIC-14 WB	5
Si823H4BD-IS3	HS/LS, PWM	8	EN	20 - 200	No	No	SOIC-14 WB	5
Si823H4CD-IS3	HS/LS, PWM	12	EN	20 - 200	No	No	SOIC-14 WB	5
Si823H5AD-IS3	Dual, VIA, VIB	6	EN	N/A	No	No	SOIC-14 WB	5
Si823H5BD-IS3	Dual, VIA, VIB	8	EN	N/A	No	No	SOIC-14 WB	5
Si823H5CD-IS3	Dual, VIA, VIB	12	EN	N/A	No	No	SOIC-14 WB	5
Si823H6AD-IS3	Dual, VIA, VIB	6	DIS	N/A	No	No	SOIC-14 WB	5
Si823H6BD-IS3	Dual, VIA, VIB	8	DIS	N/A	No	No	SOIC-14 WB	5
Si823H6CD-IS3	Dual, VIA, VIB	12	DIS	N/A	No	No	SOIC-14 WB	5
Si823H7AD-IS3	Dual, VIA, VIB	6	EN	N/A	No	Yes	SOIC-14 WB	5
Si823H7BD-IS3	Dual, VIA, VIB	8	EN	N/A	No	Yes	SOIC-14 WB	5
Si823H7CD-IS3	Dual, VIA, VIB	12	EN	N/A	No	Yes	SOIC-14 WB	5

Ordering Part Number	Configuration	Output UVLO (V)	Enable / Disable	Dead Time Setting (ns)	Deglitch	Delayed Startup Time	Package Type	Isolation Rating (kVrms)
Si823H8AD-IS3	HS/LS, PWM	6	DIS	20 - 200	No	No	SOIC-14 WB	5
Si823H8BD-IS3	HS/LS, PWM	8	DIS	20 - 200	No	No	SOIC-14 WB	5
Si823H8CD-IS3	HS/LS, PWM	12	DIS	20 - 200	No	No	SOIC-14 WB	5

- All products are rated at 4 A sink and source output drive current max.
- All packages are RoHS-compliant with peak reflow temperatures of 260 °C according to the JEDEC industry standard classifications and peak solder temperatures.
- “Si” and “SI” are used interchangeably.
- All HS/LS drivers have built-in overlap protection while the single and dual drivers do not.
- All options are rated for ambient temperatures from -40 °C to +125 °C, and are recommended for industrial grade operation.

### Automotive Grade OPNs

Automotive-grade devices are built using automotive-specific flows at all steps in the manufacturing process to ensure robustness and low defectivity. These devices are supported with AIAG-compliant Production Part Approval Process (PPAP) documentation, and feature International Material Data System (IMDS) and China Automotive Material Data System (CAMDS) listing. Qualifications are compliant with AEC-Q100, and a zero-defect methodology is maintained throughout definition, design, evaluation, qualification, and mass production steps.

**Table 1.2. Ordering Guide for Automotive Grade OPNs**

Ordering Part Number	Configuration	Output UVLO (V)	Enable / Disable	Dead Time Setting (ns)	Deglitch	Delayed Startup Time	Package Type	Isolation Rating (kVrms)
<b>Contact Silicon Labs for Product Options Below</b>								
Si823H8AB-AM1	HS/LS, PWM	6	DIS	20 - 200	No	No	QFN-14	2.5
Si823H6BB-AS1	Dual, VIA,VIB	8	DIS	N/A	No	No	SOIC-16 NB	2.5
Si823H1BD-AS3**	HS/LS, VIA/VIB	8	DIS	20 - 200	No	No	SOIC-14 WB	5

#### Note:

- All packages are RoHS-compliant with peak reflow temperatures of 260 °C according to the JEDEC industry standard classifications.
- “Si” and “SI” are used interchangeably.
- An “R” at the end of the part number denotes tape and the reel packaging option.
- Automotive-Grade devices (with an “-A” suffix) are identical in construction materials and electrical parameters to their Industrial-Grade (with an “-I” suffix) version counterpart. Automotive-Grade products are produced utilizing full automotive process flows and additional statistical process controls throughout the manufacturing flow. The Automotive-Grade part number is included on shipping labels.
- Additional Ordering Part Numbers may be available in Automotive-Grade. Please contact your local Silicon Labs sales representative for further information.
- In [Top Markings](#), the Manufacturing Code represented by either “RTTTTT” or “TTTTTT” contains as its first character a letter in the range N through Z to indicate Automotive-Grade.
- \*\* Contact Silicon Labs for Si823H1BD-AS3 availability.

# Table of Contents

<b>1. Ordering Guide</b>	<b>2</b>
<b>2. System Overview</b>	<b>7</b>
2.1 Functional Description	7
2.2 Family Overview and Logic Operation During Startup	8
2.2.1 Device Behavior	8
2.3 Layout Considerations	9
2.4 Undervoltage Lockout Operation	9
2.4.1 Device Startup	9
2.4.2 Undervoltage Lockout	10
2.5 Control Inputs	11
2.6 Enable Input	11
2.7 Disable Input	11
2.8 Delayed Startup Time	11
2.9 Programmable Dead Time and Overlap Protection	12
2.10 De-glitch Feature	13
2.11 Thermal Protection	13
2.12 Driver Output Booster Function	13
<b>3. Applications</b>	<b>14</b>
3.1 Si823H9 Single Driver	14
3.2 PWM Input Driver	15
3.3 Dual Driver or HS/LS Driver	16
<b>4. Electrical Characteristics</b>	<b>17</b>
4.1 Typical Operating Characteristics	27
<b>5. Top-Level Block Diagrams</b>	<b>30</b>
<b>6. Pin Descriptions</b>	<b>34</b>
<b>7. Package Outlines</b>	<b>36</b>
7.1 8-Pin Narrow Body SOIC (SOIC-8)	36
7.2 8-Pin Wide Body Stretched SOIC (SSO-8)	37
7.3 16-Pin Narrow Body SOIC (SOIC-16 NB)	38
7.4 14-Pin Wide Body SOIC (SOIC-14 WB)	40
7.5 14 LD QFN (QFN-14)	41
<b>8. Land Patterns</b>	<b>42</b>
8.1 8-Pin Narrow Body SOIC	42
8.2 8-Pin Wide Body Stretched SOIC	43
8.3 16-Pin Narrow Body SOIC	44

8.4	14-Pin Wide Body SOIC . . . . .	.45
8.5	14 LD QFN . . . . .	.46
<b>9.</b>	<b>Top Markings . . . . .</b>	<b>.47</b>
9.1	8-Pin Narrow Body SOIC . . . . .	.47
9.2	8-Pin Wide Body Stretched SOIC. . . . .	.48
9.3	16-Pin Narrow Body SOIC . . . . .	.49
9.4	14-Pin Wide Body SOIC . . . . .	.50
9.5	14 LD QFN . . . . .	.51
<b>10.</b>	<b>Revision History. . . . .</b>	<b>.52</b>
10.1	Revision 0.61 . . . . .	.52
10.2	Revision 0.6 . . . . .	.52
10.3	Revision 0.5 . . . . .	.52
10.4	Revision 0.34 . . . . .	.52
10.5	Revision 0.33 . . . . .	.52
10.6	Revision 0.1 . . . . .	.52

## 2. System Overview

### 2.1 Functional Description

The operation of an Si823Hx channel is analogous to that of an optocoupler and gate driver, except an RF carrier is modulated instead of light. This simple architecture provides a robust isolated data path and requires no special considerations or initialization at start-up. A simplified block diagram for a single Si823Hx channel is shown in the figure below.

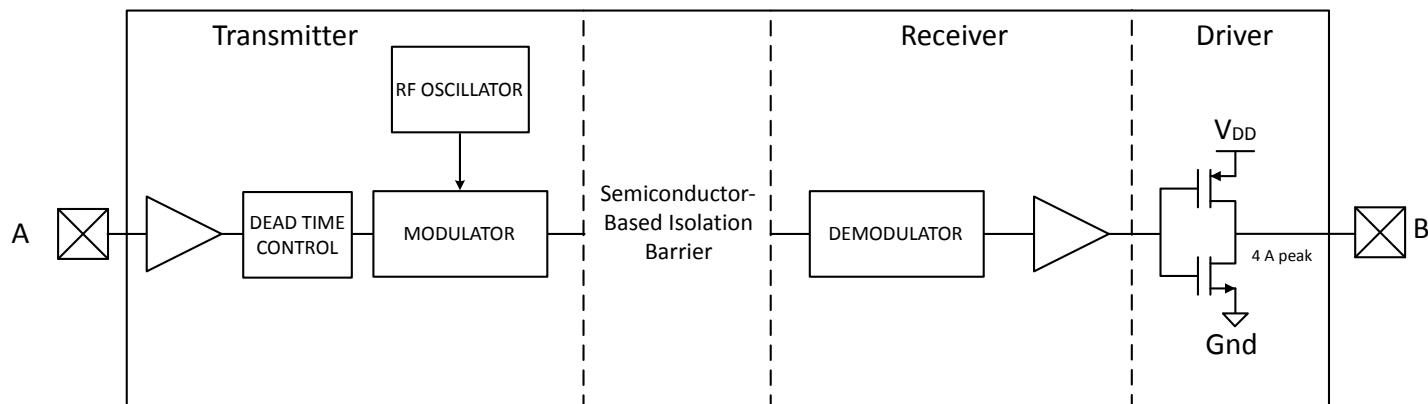

Figure 2.1. Simplified Channel Diagram

A channel consists of an RF Transmitter and RF Receiver separated by a semiconductor based isolation barrier. Referring to the Transmitter, input A modulates the carrier provided by an RF oscillator using on/off keying. The Receiver contains a demodulator that decodes the input state according to its RF energy content and applies the result to output B via the output driver. This RF on/off keying scheme is superior to pulse code schemes as it provides best-in-class noise immunity, low power consumption, and better immunity to magnetic fields. See the figure below for more details.

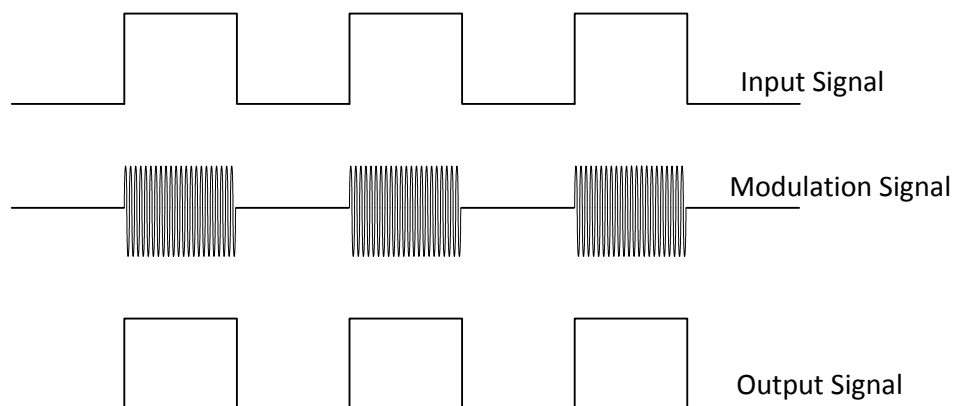

Figure 2.2. Modulation Scheme

## 2.2 Family Overview and Logic Operation During Startup

The Si823Hx family of isolated drivers consists of single, high-side/low-side, and dual driver configurations.

### 2.2.1 Device Behavior

The following are truth tables for the Si823Hx families.

**Table 2.1. Si823H1/2/3/5/6/7 HS/LS and Dual (VIA/VIB) Drivers**

VIA	VIB	DIS / EN <sup>1</sup>	VDDI	VDDA	Vddb	VOA	VOB	Notes
H	L	L / H	P	P	P	H	L	
L	H	L / H	P	P	P	L	H	
H	H	L / H	P	P	P	H / L <sup>4</sup>	H / L <sup>4</sup>	
L	L	L / H	P	P	P	L	L	
X	X	H / L or NC	P	P	P	L	L	Device disabled
X	X	X	UP <sup>2</sup>	P	P	L	L	Fail-safe output when VDDI unpowered
H	X	L / H	P	P	UP	H	UD <sup>3</sup>	VOB depends on Vddb state
L	X	L / H	P	P	UP	L	UD <sup>3</sup>	
X	H	L / H	P	UP	P	UD <sup>3</sup>	H	VOA depends on VDDA state
X	L	L / H	P	UP	P	UD <sup>3</sup>	L	

P = Powered, UP = Unpowered

**Notes:**

1. There are different product options available. For any one product, either EN or DIS is present.
2. The chip can be powered through the VIA, VIB input ESD diodes even if VDDI is unpowered. It is recommended that inputs be left unpowered when VDDI is unpowered.
3. UD = undetermined if same side power is UP.
4. On the HS/LS driver (Si823H1/2/3) options, VOA and VOB = L when VIA and VIB = H; for dual driver options (Si823H5/6), VOA and VOB = H when VIA and VIB = H.

Table 2.2. Si823H4/8 PWM Input HS/LS Drivers

PWM	DIS / EN <sup>1</sup>	VDDI	VDDA	VDDB	VOA	VOB	Notes
H	L / H	P	P	P	H	L	See Figure 2.7 Dead Time note and Dead Time Waveforms for High-Side/Low-Side Drivers on page 12 for timing
L	L / H	P	P	P	L	H	
X	H / L or NC	P	P	P	L	L	Device disabled
X	X	UP <sup>2</sup>	P	P	L	L	Fail-safe output when VDDI unpowered
H	L / H	P	P	UP	H	UD <sup>3</sup>	VOB depends on VDDB state
L	L / H	P	P	UP	L	UD <sup>3</sup>	
H	L / H	P	UP	P	UD <sup>3</sup>	L	VOA depends on VDDA state
L	L / H	P	UP	P	UD <sup>3</sup>	H	

P = Powered, UP = Unpowered

**Note:**

1. There are different product options available. For any one product, either EN or DIS is present.
2. The chip can be powered through the VIA, VIB input ESD diodes even if VDDI is unpowered. It is recommended that inputs be left unpowered when VDDI is unpowered. The EN pin has a special ESD circuit that prevents the IC from powering up through the EN pin.
3. UD = undetermined if same side power is UP.

## 2.3 Layout Considerations

It is most important to minimize ringing in the drive path and noise on the Si823Hx VDD lines. Care must be taken to minimize parasitic inductance in these paths by locating the Si823Hx as close to the device it is driving as possible. In addition, the VDD supply and ground trace paths must be kept short. For this reason, the use of power and ground planes is highly recommended. A split ground plane system having separate ground and VDD planes for power devices and small signal components provides the best overall noise performance. For placement of the decoupling capacitors, it is recommended that the 0.1  $\mu\text{f}$  capacitor should be placed as close as possible to the VDDA/B supply pins. The 10  $\mu\text{f}$  capacitor can be a little farther away.

## 2.4 Undervoltage Lockout Operation

Device behavior during start-up, normal operation and shutdown is shown in [2.4.2 Undervoltage Lockout](#), where UVLO+ and UVLO- are the positive-going and negative-going thresholds respectively. Note that outputs VOA and VOB default low when input side power supply (VDDI) is not present.

### 2.4.1 Device Startup

Outputs VOA and VOB are held low during power-up until VDD is above the UVLO threshold for time period tSTART. Following this, the outputs follow the states of inputs VIA and VIB.

## 2.4.2 Undervoltage Lockout

Undervoltage Lockout (UVLO) is provided to prevent erroneous operation during device startup and shutdown or when VDD is below its specified operating circuits range. The input (control) side, Driver A, and Driver B each have their own undervoltage lockout monitors.

The Si823Hx input side enters UVLO when  $VDDI \leq VDDI_{UV-}$ , and exits UVLO when  $VDDI > VDDI_{UV+}$ . The driver outputs, VOA and VOB, remain low when the input side of the Si823Hx is in UVLO and their respective VDD supply (VDDA, VDDDB) is within tolerance. Each driver output can enter or exit UVLO independently. For example, VOA unconditionally enters UVLO when VDDA falls below  $VDDA_{UV-}$  and exits UVLO when VDDA rises above  $VDDA_{UV+}$ .

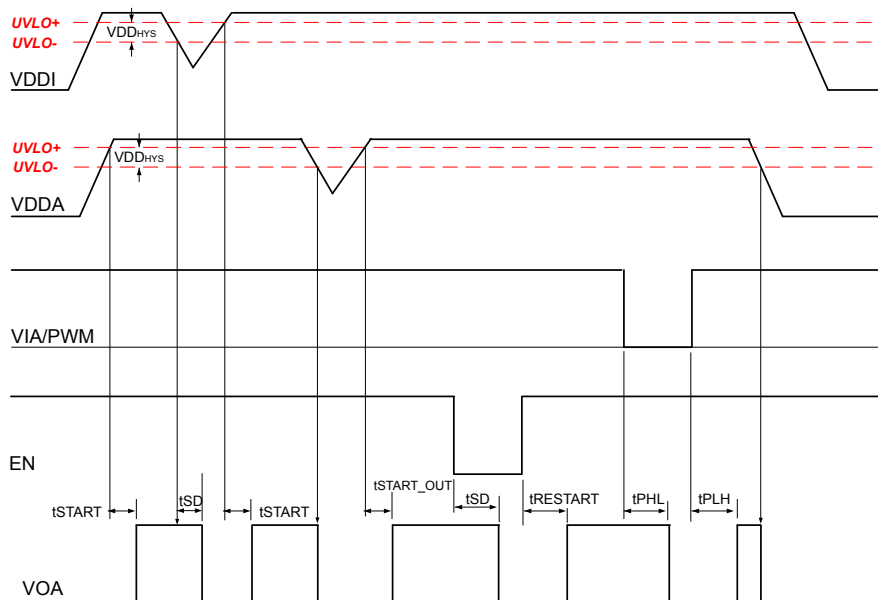

Figure 2.3. Si823H2/4/5/7/9 Device Behavior During Normal Operation and Shutdown

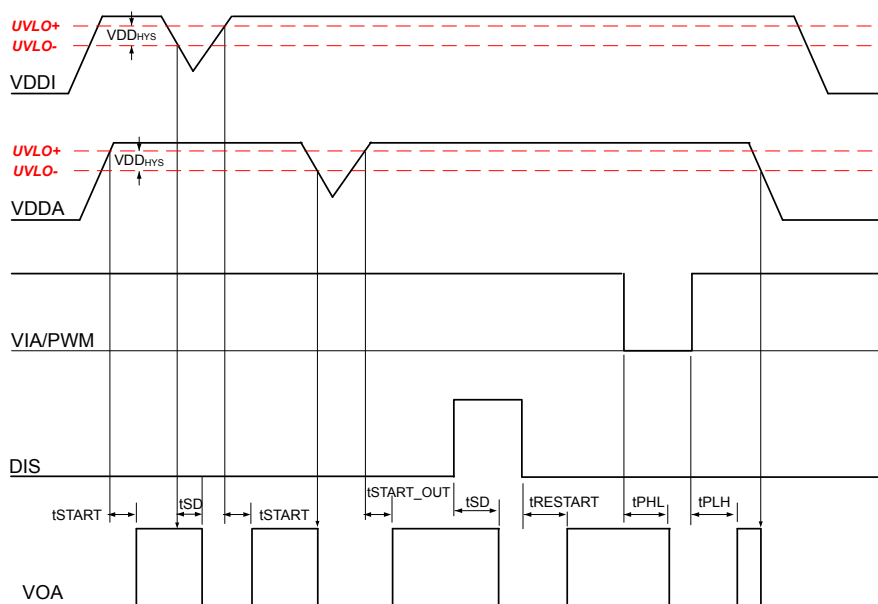
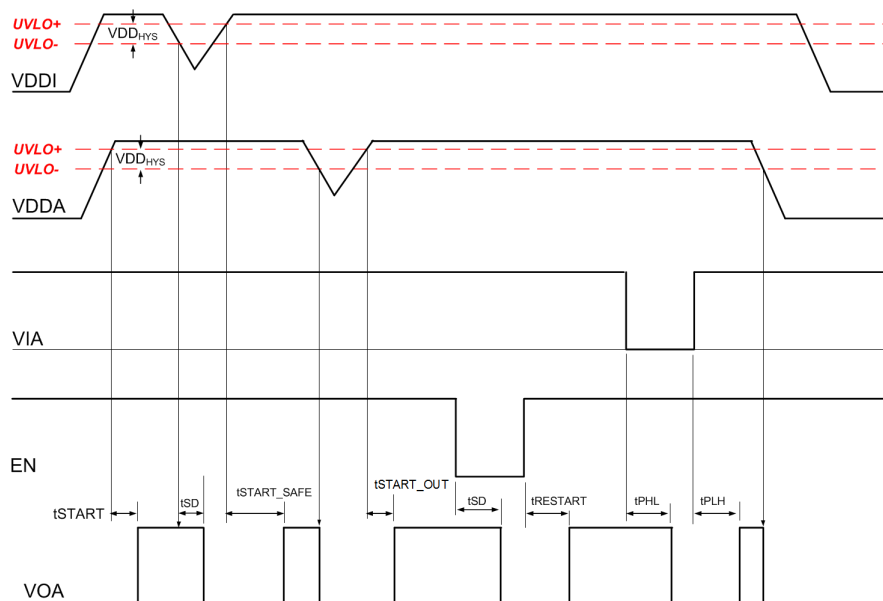

Figure 2.4. Si823H1/3/6/8 Device Behavior During Normal Operation and Shutdown



**Figure 2.5. Si823H7 (Delayed Startup Time of t<sub>START\_SAFE</sub>) Device Behavior During Normal Operation and Shutdown**

## 2.5 Control Inputs

VIA, VIB, and PWM inputs are high-true, TTL level-compatible logic inputs. A logic high signal on VIA or VIB causes the corresponding output to go high. For PWM input versions (Si823H4/8), VOA is high and VOB is low when the PWM input is high, and VOA is low and VOB is high when the PWM input is low.

## 2.6 Enable Input

When brought low, the EN input unconditionally drives VOA and VOB low regardless of the states of VIA and VIB. Device operation terminates within t<sub>SD</sub> after EN = VIL and resumes within t<sub>RESTART</sub> after EN = VIH. The EN input has no effect if VDDI is below its UVLO level (i.e., VOA, VOB remain low). There is an internal pull-down resistor of 100 kOhm on the EN pin.

## 2.7 Disable Input

When brought high, the DISABLE input unconditionally drives VOA and VOB low regardless of the states of VIA and VIB. Device operation terminates within t<sub>SD</sub> after DISABLE = VIH and resumes within t<sub>RESTART</sub> after DISABLE = VIL or open. The DISABLE input has no effect if VDDI is below its UVLO level (i.e., VOA, VOB remain low). There is an internal pull-down resistor of 100 kOhm on the DIS pin.

## 2.8 Delayed Startup Time

Product options Si823H7 have a safe startup time (t<sub>STARTUP\_SAFE</sub>) of 1 ms typical from input power valid to output showing valid data. This feature allows users to proceed through a safe initialization sequence with a monotonic output behavior.

## 2.9 Programmable Dead Time and Overlap Protection

All high-side/low-side drivers and PWM drivers (single input) include programmable dead time, which adds a user-programmable delay between transitions of VOA and VOB. When asserted, dead time is present only on output rising edges, when the other input is also high. If only one input is high, there is no dead time added to the output transition. Please see figure below for a graphical representation of dead time implementation. The amount of dead time delay (DT) is programmed by a single resistor (RDT) connected from the DT input to ground per the equation below. The DT is measured as the time elapsed between VOA low to VOB high and vice versa.

For products with Dead Time setting of 20-200ns:

$DT \sim 1.8 \times (RDT) + 12$ , where DT = Typical Dead Time in ns, RDT = Dead Time Resistor in k $\Omega$

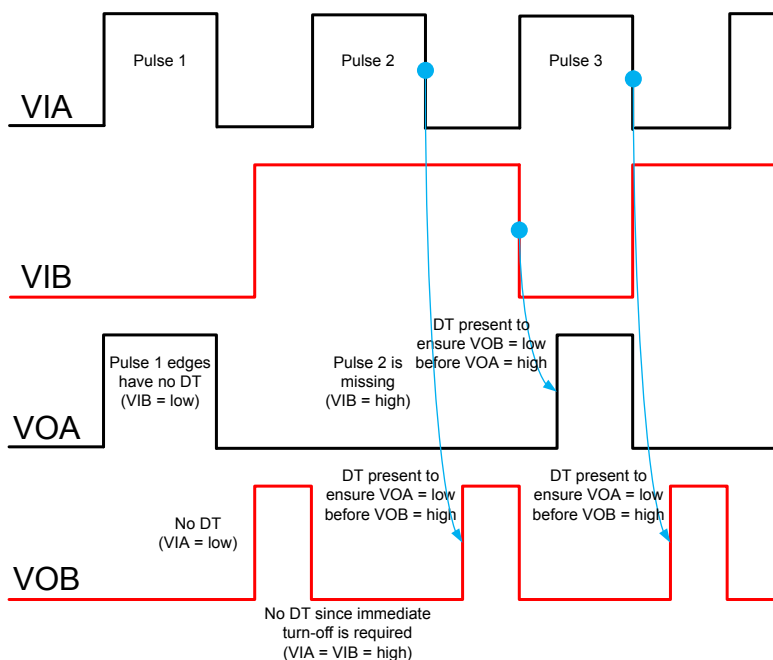

Figure 2.6. Dead Time Implementation & Behavior

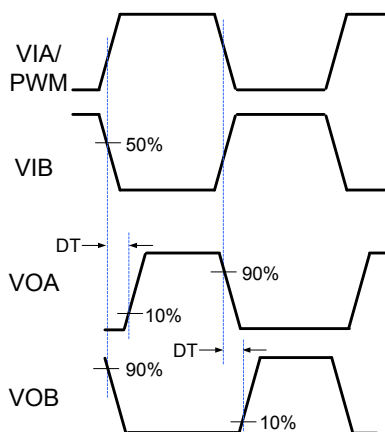

Figure 2.7. Dead Time Waveforms for High-Side/Low-Side Drivers

## 2.10 De-glitch Feature

A de-glitch feature is provided on some devices, as defined in the [1. Ordering Guide](#). The de-glitch basically provides an internal time delay during which any noise is ignored and will not pass through the IC. There are two distinct de-glitch circuits, one each on the input and output (after the signal has been coupled across the isolation barrier) side. Please see [Table 4.1 Electrical Characteristics on page 17](#) for the delays associated with these circuits.

## 2.11 Thermal Protection

Si823Hx has built-in temperature sensors for protection against high temperature resulting from overloading the driver, too high of an ambient temperature, or external component failures. If high internal temperature (>150 °C) is detected, the output is forced to low state.

## 2.12 Driver Output Booster Function

The output driver pull-up capability is enabled by two parallel drivers: a standard PMOS device and an NMOS helper transistor. The PMOS device provides a standard 1 A pull-up and the the DC pull-up when VO is close to VDD. The NMOS helper provides higher pull-up currents around the miller plateau of the driven power transistor, supporting fast turn-on times. See [Figure 2.8 on page 13](#) for the internal architecture scheme and [Figure 2.9 on page 13](#) for the pull-up current characteristics.

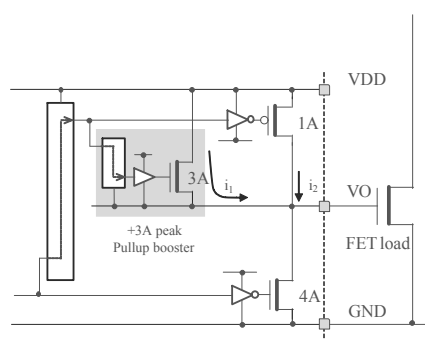

**Figure 2.8. Pull-Up Booster Simplified Architecture**

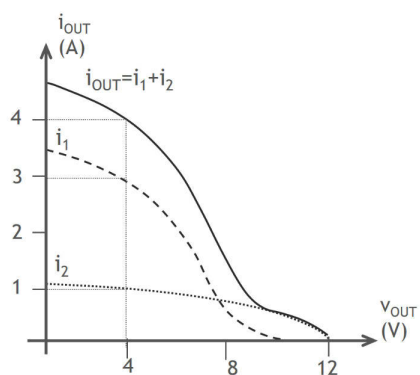

**Figure 2.9. Pull-Up Current Characteristics, VDD = 12 V**

### 3. Applications

The following examples illustrate typical circuit configurations using the Si823Hx.

#### 3.1 Si823H9 Single Driver

The following figure shows the Si823H9 single driver controlled by a single digital signal. Note that the input side of the Si823H9 requires VDDI in the range of 3.0 to 5.5 V, while the VDD output side supply must be between 5.5 and 30 V referred to GNDB. The VO+ (pull-up) and VO- (pull-down) outputs are shown connected to the gate of Q1. The gate resistors Rg1 and Rg2 shown could be different values to allow full utilization of the separate pull-up and pull-down outputs provided to control turn-on and turn-off times respectively. Also note that the bypass capacitors on the Si823H9 should be located as close to the chip as possible.

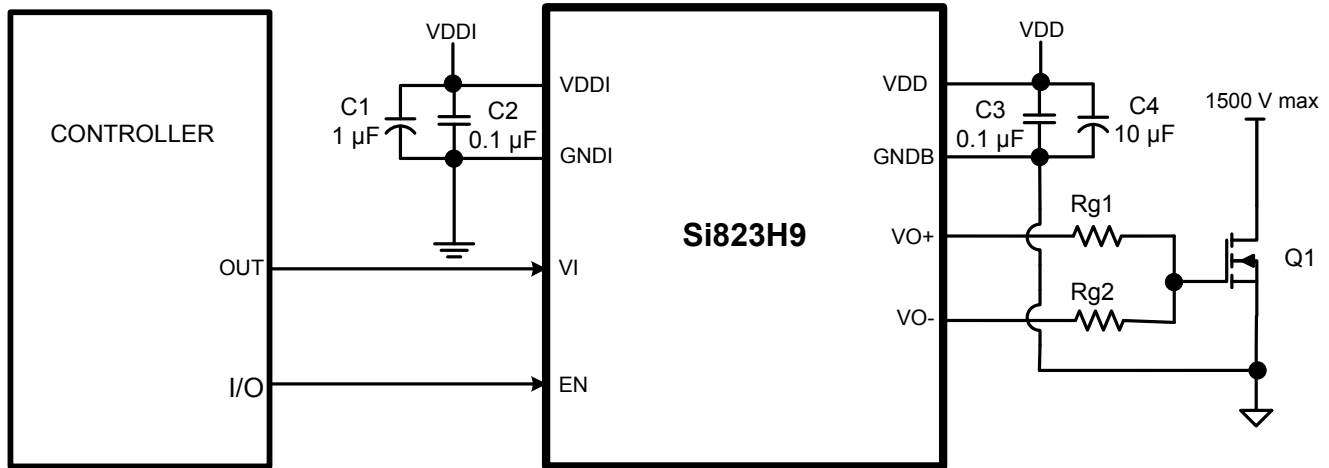

Figure 3.1. Si823H9 Single Driver

### 3.2 PWM Input Driver

The following figure shows the Si823Hx controlled by a single PWM signal.

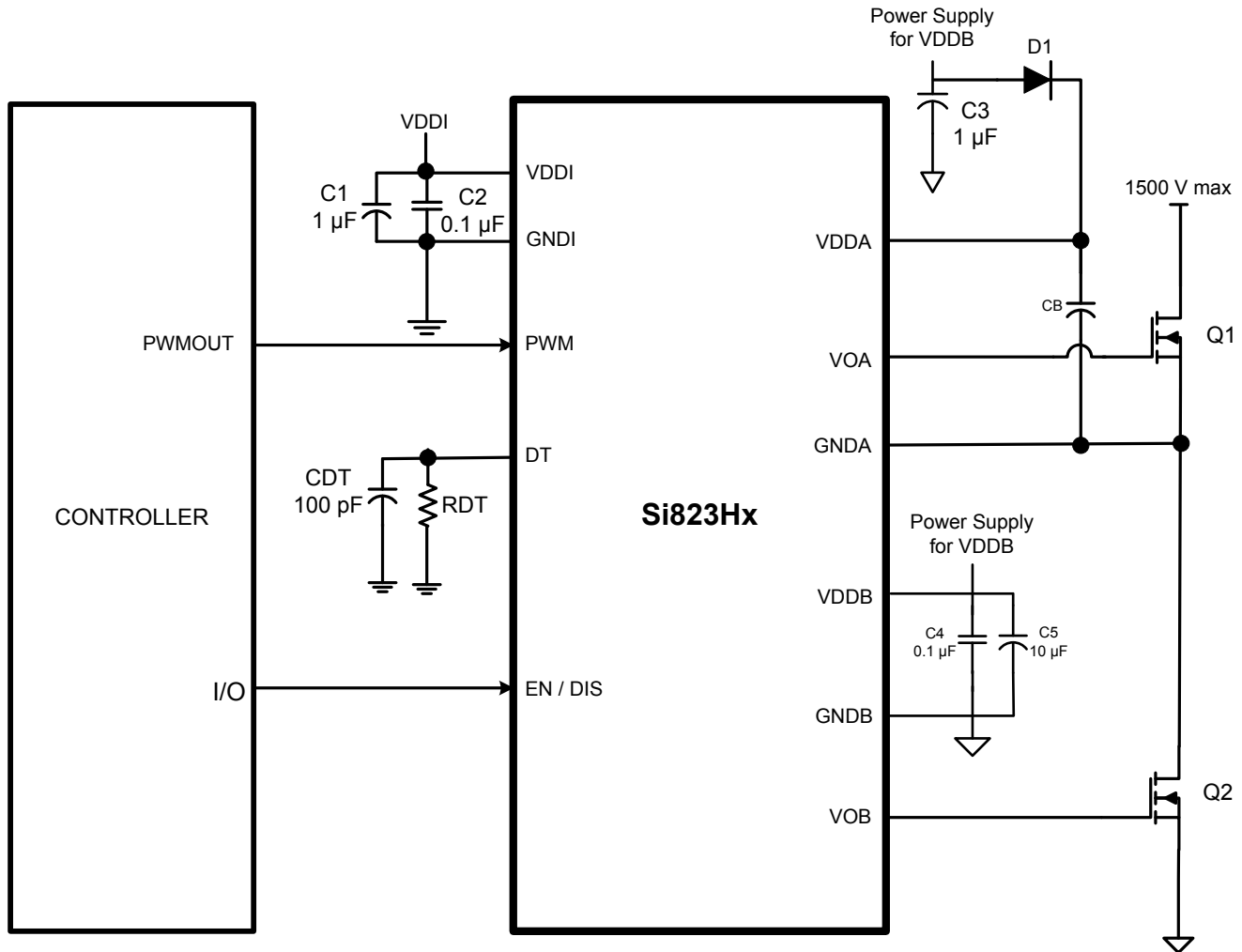

Figure 3.2. Si823H4/8 PWM input with EN/DIS Pin Application Diagram

In the above figure, D1 and CB form a conventional bootstrap circuit that allows VOA to operate as a high-side driver for Q1, which has a maximum drain voltage of 1500 V. VOB is connected as a conventional low-side driver. Note that the input side of the Si823Hx requires VDDI in the range of 3.0 to 5.5 V, while the VDDA and VDDB output side supplies must be between 5.5 and 30 V referred to their respective grounds. The boot-strap start up time will depend on the CB cap chosen. Also note that the bypass capacitors on the Si823Hx should be located as close to the chip as possible.

### 3.3 Dual Driver or HS/LS Driver

The following figure shows the device configured as a dual driver or HS/LS driver. Note that the drain voltages of Q1 and Q2 can be referenced to a common ground or to different grounds with as much as 1500 Vdc between them.

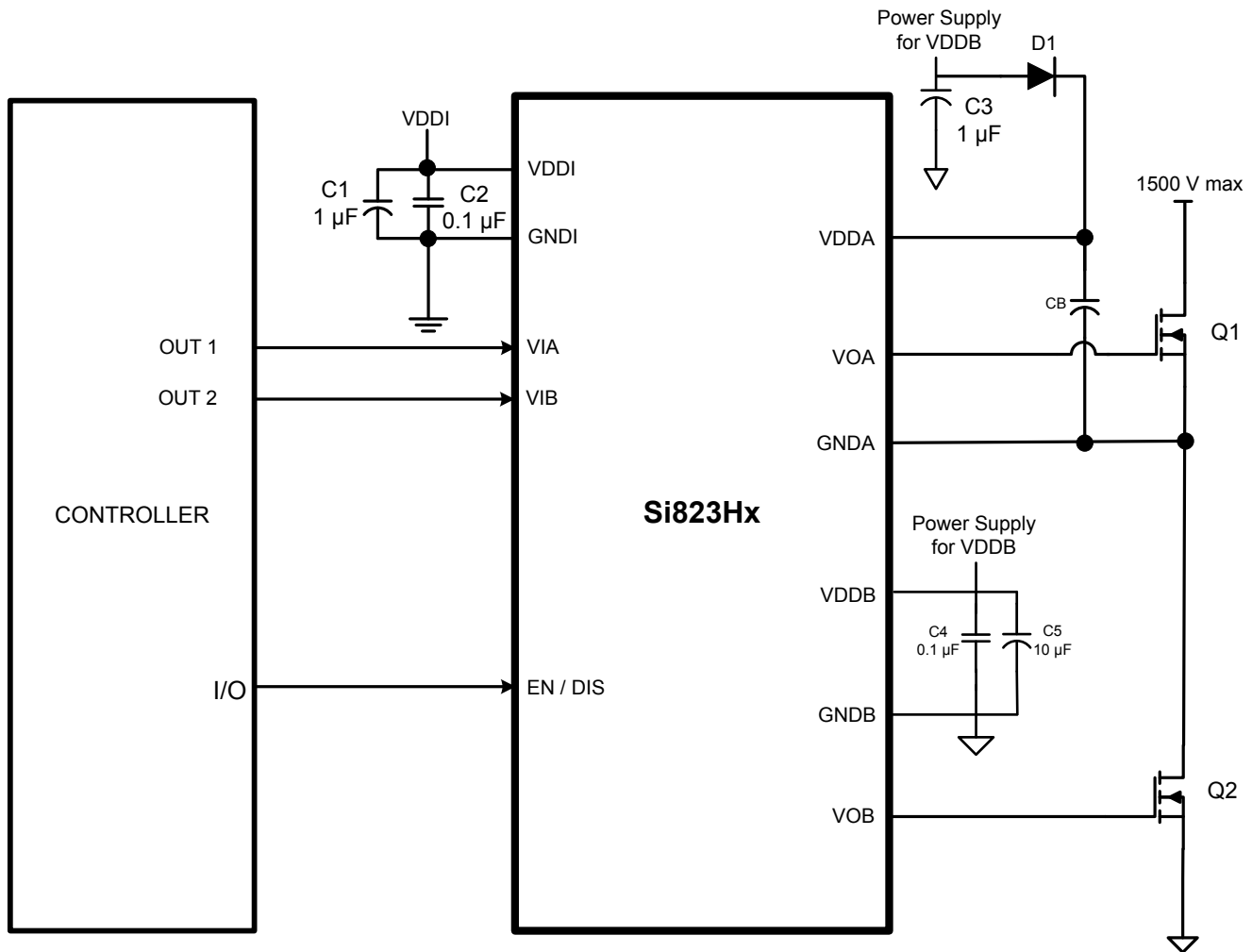

Figure 3.3. Si823H1/2/3/5/6/7 with EN/DIS Pin Application Diagram

Because each output driver resides on its own die, the relative voltage polarities of VOA and VOB can reverse without damaging the driver. A dual driver can operate as a dual low-side or dual high-side driver and is unaffected by static or dynamic voltage polarity changes.

## 4. Electrical Characteristics

Table 4.1. Electrical Characteristics<sup>1, 2</sup>

Parameter	Symbol	Test Condition	Min	Typ	Max	Unit
<b>DC Specifications</b>						
Input-side Power Supply Voltage	VDDI		3.0		5.5	V
Driver Supply Voltage	VDDA, VDDB	Voltage between VDDA and GNDA, and VDDB and GNDB	5.5	—	30	V
Input Supply Quiescent Current EN = 0	IDDI(Q)		—	1.3	2.0	mA
Output Supply Quiescent Current, per channel EN = 0	IDDA(Q), IDDB(Q)		—	2.3	2.8	mA
Input Supply Active Current	IDDI	Input freq = 1 MHz	—	2.2	3.3	mA
Output Supply Active Current, per channel	IDDA/B	Input freq = 1 MHz, no load	—	5.6	9.0	mA
Input Pin Leakage Current, VIA, VIB, PWM	IVIA, IVIB, IPWM		-10	—	+10	μA
Input Pin Leakage Current, EN	IENABLE		-40	—	+40	μA
Logic High Input Threshold	VIH	TTL Levels	1.6	1.8	2.0	V
Logic Low Input Threshold	VIL	TTL Levels	0.8	1	1.2	V
Input Hysteresis	VIHYST			800	—	mV
Logic High Output Voltage	VOAH, VOBH	IOA, IOB = -1 mA	VDDA, VDDB -0.064	—	—	V
Logic Low Output Voltage	VOAL, VOBL	IOA, IOB = 1 mA	—	—	0.04	V
Output Short-Circuit Pulsed Sink Current	IOA(SCL), IOB(SCL)	CL = 220 nF	—	4.0	—	A
Output Short-Circuit Pulsed Source Current	IOA(SCH), IOB(SCH)	CL = 220 nF	—	4.0	—	A
Output Sink Resistance	RON(SINK)		—	1.0	—	Ω
Output Source Resistance	RON(SOURCE)		—	4.2	—	Ω
VDDI Undervoltage Threshold	VDDIU+	VDDI rising	1.9	2.1	2.7	V
	VDDIU-	VDDI falling	1.85	2.0	2.6	V
VDDI Lockout Hysteresis	VDDIHYS		30	60	—	mV
VDDA, VDDB Undervoltage Threshold	VDDAU+, VDDBU+	VDDA, VDDB rising	5.6	6.1	6.6	V
6 V Threshold			7.5	8.1	8.8	
8 V Threshold			11.3	12.2	13.4	
VDDA, VDDB Undervoltage Threshold	VDDAU-, VDDBU-	VDDA, VDDB falling	5.4	5.8	6.3	V
6 V Threshold			7.0	7.6	8.2	
8 V Threshold			10.3	11.1	12.0	
12 V Threshold						

Parameter	Symbol	Test Condition	Min	Typ	Max	Unit
VDDA, VDDB Lockout Hysteresis	VDDAHYS, VDDBHYS	UVLO = 6 V	270	320	—	mV
		UVLO = 8 V	470	550	—	
		UVLO = 12 V	950	1200	—	
<b>AC Specifications</b>						
UVLO Fault Shutdown Time		VDDAUV– to VOA low VDDBUV– to VOB low	—	10	—	ns
Minimum Pulse Width (No Load)	PW <sub>min</sub>	Si823H1/2/5/6/7/9x (with no de-glitch)	—	10	—	ns
		Si823H3x (with de-glitch)	—	76	—	ns
Propagation Delay VDDA/B = 12 V CL = 0 pF	t <sub>pHL</sub> , t <sub>pLH</sub>	Si823H1/2/5/6/7/9x (with no de-glitch)	10	19	30	ns
	t <sub>pHL</sub> , t <sub>pLH</sub>	Si823H3x (with de-glitch)	56	89	116	ns
	t <sub>pHL</sub>	Si823H4/8 (with no de-glitch; measured with 6 kΩ RDT resistor; includes minimum dead time)	10	19	30	ns
	t <sub>pLH</sub>		14	39	58	ns
Output Channel to Channel Skew	t <sub>PSK</sub>			3	5	ns
Propagation Delay Skew <sup>3</sup>	t <sub>PSK(P-P)</sub>		—	2.0	4.5	ns
Pulse Width Distortion  t <sub>pLH</sub> – t <sub>pHL</sub>	PWD	VDDA/B = 12 V CL = 0 pF	—	2.7	5	ns
Programmed Dead Time when available	DT	RDT = 6 kΩ	10	20	28	ns
		RDT = 15 kΩ	29	38	47	
		RDT = 100 kΩ	145	180	210	
Output Rise and Fall Time	t <sub>R</sub> , t <sub>F</sub>	CL = 200 pF	—	—	12	ns
Shutdown Time from Enable False (or Disable True)	t <sub>SD</sub>	All options with no de-glitch	—	—	35	ns
		All options with de-glitch	—	—	65	
Restart Time from Enable True (or Disable False)	t <sub>RESTART</sub>	All options with no de-glitch	—	—	35	ns
		All options with de-glitch	—	—	65	
Device Start-up Time Input	t <sub>START_SAFE</sub>	Si823H7	—	1	—	ms
Time from VDDI_ = VDDI_UV+ to VOA, VOB = VIA, VIB	t <sub>START</sub>	Si823H1/2/3/4/5/6/8/9	—	40	—	μs
Device Start-up Time Output	t <sub>START_OUT</sub>	Time from VDDA/B = VDDA/ B_UV+ to VOA, VOB = VIA, VIB	—	60	—	μs
Common Mode Transient Immunity	CMTI	VIA, VIB, PWM = VDDI or 0 V VCM = 1500 V	125	—	—	kV/μs

Parameter	Symbol	Test Condition	Min	Typ	Max	Unit
<b>Note:</b>						
1. $3.0\text{ V} < V_{DDI} < 5.5\text{ V}$ ; $6.5\text{ V} < V_{DDA}, V_{DDB} < 30\text{ V}$ ; $T_A = -40$ to $+125\text{ }^\circ\text{C}$ .						
2. Typical specs at $25\text{ }^\circ\text{C}$ , $V_{DDA} = V_{DDB} = 12\text{ V}$ for $5\text{ V}$ and $8\text{ V}$ UVLO devices, otherwise $15\text{ V}$ .						
3. $t_{PSK(P-P)}$ is the magnitude of the difference in propagation delay times measured between different units operating at the same supply voltages, load, and ambient temperature.						

**Test Circuits**

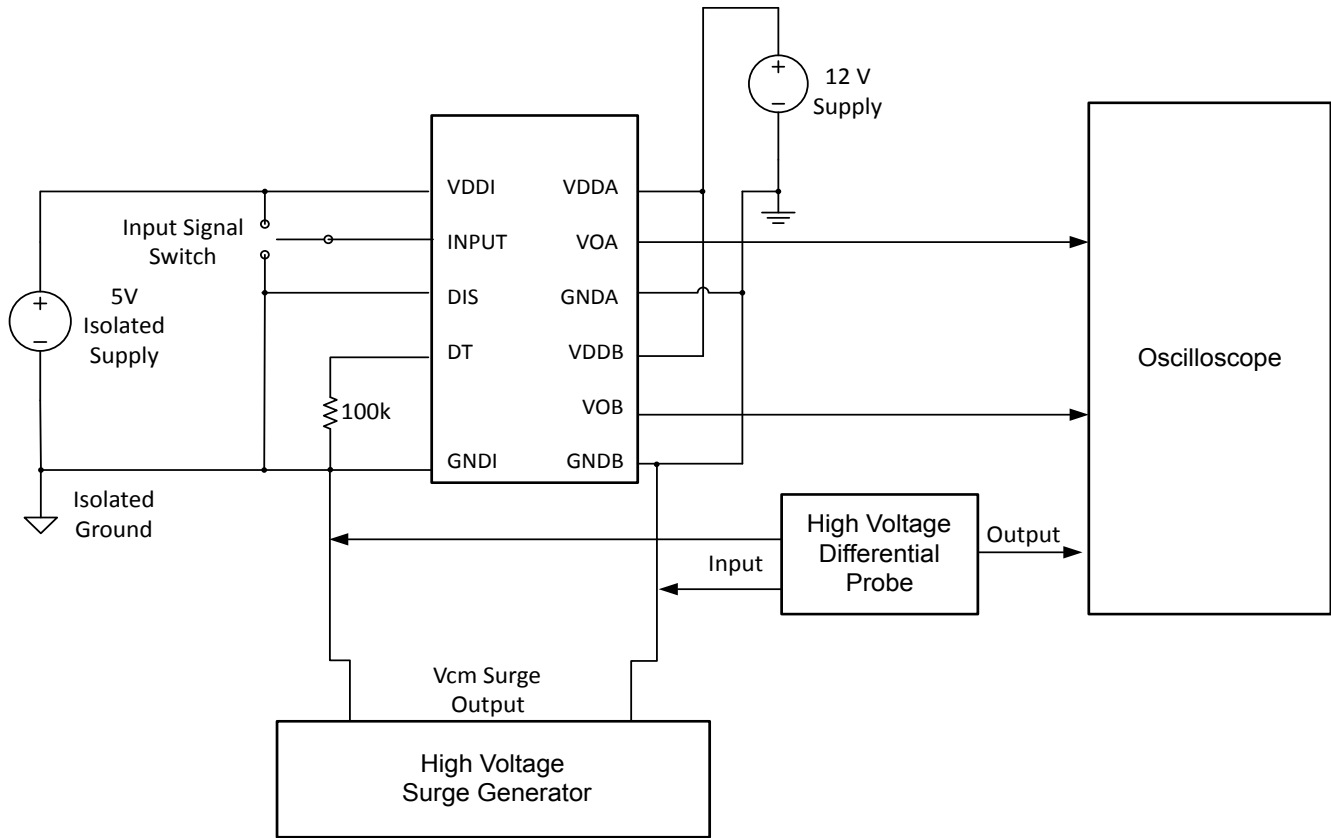

**Figure 4.1. Common Mode Transient Immunity (CMTI) Test Circuit**

**Table 4.2. Regulatory Information (Pending)<sup>1, 3, 4</sup>**

<b>CSA</b>
The Si823Hx is certified under CSA, see Master Contract Number 232873.
60950-1, 62368-1: Up to 600 V <sub>RMS</sub> reinforced insulation working voltage; up to 1000 V <sub>RMS</sub> basic insulation working voltage.
<b>VDE</b>
The Si823Hx is certified according to VDE 0884-10. For more details, see Certificate 40037519.
VDE 0884-10: Up to 891 V <sub>peak</sub> for reinforced insulation working voltage.
60950-1, 62368-1: Up to 600 V <sub>RMS</sub> reinforced insulation working voltage; up to 1000 V <sub>RMS</sub> basic insulation working voltage.
<b>UL</b>
The Si823Hx is certified under UL1577 component recognition program. For more details, see File E257455.
Rated up to 5000 V <sub>RMS</sub> isolation voltage for basic protection.
<b>CQC</b>
The Si823Hx is certified under GB4943.1-2011.
Rated up to 600 V <sub>RMS</sub> reinforced insulation working voltage; up to 1000 V <sub>RMS</sub> basic insulation working voltage.
<b>Note:</b>
<ol style="list-style-type: none"> <li>1. Regulatory Certifications apply to 2.5 kV<sub>RMS</sub> rated devices which are production tested to 3.0 kV<sub>RMS</sub> for 1sec.</li> <li>2. Regulatory Certifications apply to 3.75 kV<sub>RMS</sub> rated devices which are production tested to 4.5 kV<sub>RMS</sub> for 1sec.</li> <li>3. Regulatory Certifications apply to 5.0 kV<sub>RMS</sub> rated devices which are production tested to 6.0 kV<sub>RMS</sub> for 1sec.</li> <li>4. For more information, see Chapter 1. <a href="#">Ordering Guide</a>.</li> </ol>

Table 4.3. Insulation and Safety-Related Specifications

Parameter	Symbol	Test Condition	Value					Unit
			NB SOIC-16 2.5 kVrms	NB SOIC-8 2.5 kVrms	SSO-8 5 kVrms	WB SOIC-14 5 kVrms	QFN-14 2.5 kVrms	
Nominal External Air Gap (Clearance) <sup>1</sup>	CLR		4.7	4.7	9.0	8.0	3.5	mm
Nominal External Tracking (Creepage) <sup>1</sup>	CPG		3.9	3.9	8.0	8.0	3.5	mm
Minimum Internal Gap (Internal Clearance)	DTI		0.016	0.016	0.016	0.016	0.016	mm
Tracking Resistance	CTI or PTI	IEC60112	600	600	600	600	600	V
Erosion Depth	ED		0.019	0.019	0.040	0.019	Top: 0.051	mm
							Bottom: 0.087	
Resistance (Input-Output) <sup>2</sup>	R <sub>IO</sub>		10 <sup>12</sup>	10 <sup>12</sup>	10 <sup>12</sup>	10 <sup>12</sup>	10 <sup>12</sup>	Ω
Capacitance (Input-Output) <sup>2</sup>	C <sub>IO</sub>	f = 1 MHz	2.0	1.3	1.0	1.7	1.7	pF
Input Capacitance <sup>3</sup>	C <sub>I</sub>		3.0	2.8	2.8	3.0	2.9	pF

**Notes:**

- The values in this table correspond to the nominal creepage and clearance values.
- To determine resistance and capacitance, the device is converted into a 2-terminal device. All pins on side 1 and all pins on side 2 are shorted.
- Measured from input pin to ground.

Table 4.4. IEC 60664-1 Ratings

Parameter	Test Condition	Specification	
		SSO-8, WB SOIC-16	NB SOIC-8/16, QFN-14
Basic Isolation Group	Material Group	I	I
Installation Classification	Rated Mains Voltages < 150 V <sub>RMS</sub>	I-IV	I-IV
	Rated Mains Voltages < 300 V <sub>RMS</sub>	I-IV	I-IV
	Rated Mains Voltages < 400 V <sub>RMS</sub>	I-IV	I-III
	Rated Mains Voltages < 600 V <sub>RMS</sub>	I-IV	I-III

Table 4.5. VDE 0884-10 Insulation Characteristics<sup>1</sup>

Parameter	Symbol	Test Condition	Characteristic		Unit
			SSO-8, WB SO-IC-14	NB SOIC-8/16, QFN-14	
Maximum Working Insulation Voltage	$V_{IORM}$		891	560	V peak
Input to Output Test Voltage	$V_{PR}$	Method b1 ( $V_{IORM} \times 1.875 = V_{PR}$ , 100% Production Test, $t_m = 1$ sec, Partial Discharge < 5 pC)	1671	1050	V peak
Transient Overvoltage	$V_{IOTM}$	$t = 60$ s	8000	6000	V peak
				4000 (for QFN-14 only)	
Surge Voltage	$V_{IOSM}$	Tested per IEC 60065 with surge voltage with rise/decay time of 1.2 $\mu$ s/50 $\mu$ s	6250 Tested with 10 kV	6250 Tested with 10 kV	V peak
Pollution Degree (DIN VDE 0110, <a href="#">Table 4.1 Electrical Characteristics<sup>1, 2</sup> on page 17</a> )			2	2	
Insulation Resistance at $T_S$ , $V_{IO} = 500$ V	$R_S$		$>10^9$	$>10^9$	$\Omega$

**\*Note:**  
1. Maintenance of the safety data is ensured by protective circuits. The Si823Hx provides a climate classification of 40/125/21.

Table 4.6. IEC Safety Limiting Values<sup>1</sup>

Parameter	Symbol	Test Condition	NB SOIC-16	NB SOIC-8	SSO-8	WB SOIC-14	QFN-14	Unit
Safety Temperature	$T_S$		150	150	150	150	150	$^{\circ}\text{C}$
Safety Current	$I_S$	$\theta_{JA}$ Refer to package specific values for junction to air thermal resistance in <a href="#">Table 4.7</a> below $V_{DDI} = 5.5$ V, $V_{DDA} = V_{DDB} = 30$ V, $T_J = 150$ $^{\circ}\text{C}$ , $T_A = 25$ $^{\circ}\text{C}$	66	38	46	61	39	mA
Device Power Dissipation <sup>2</sup>	$P_D$		1.98	1.14	1.39	1.84	1.19	W

**Notes:**  
1. Maximum value allowed in the event of a failure. Refer to the thermal derating curve in [Figure 4.2 NB SOIC-16 Thermal Derating Curve, Dependence of Safety Limiting Values on page 24](#).  
2. Si823Hx is tested with CL = 100 pF, input 2 MHz 50% duty cycle square wave.

**Table 4.7. Thermal Characteristics**

Parameter	Symbol	NB SOIC-16	NB SOIC-8	SSO-8	WB SOIC-14	QFN-14	Unit
IC Junction-to-Air Thermal Resistance	$\theta_{JA}$	63	110	90	68	105	°C/W

**Table 4.8. Absolute Maximum Ratings<sup>1</sup>**

Parameter	Symbol	Min	Max	Unit
Ambient Temperature under Bias	TA	-40	+125	°C
Storage Temperature	TSTG	-65	+150	°C
Junction Temperature	TJ	—	+150	°C
Input-side Supply Voltage	VDDI	-0.6	6.0	V
Driver-side Supply Voltage	VDDA, VDDB	-0.6	36	V
Voltage on any Pin with respect to Ground	VIA, VIB Transient for 50 ns	-5.0	VDD + 0.5	V
	VIA, VIB, EN, DIS, DT	-0.6	VDD + 0.5	
Peak Output Current (tPW = 10 $\mu$ s, duty cycle = 0.2%)	IOPK	—	6.0	A
Lead Solder Temperature (10 s)		—	260	°C
ESD per AEC-Q100	HBM	—	4	kV
	CDM	—	0.5	kV
Maximum Isolation (Input to Output) (1 s) WB SOIC-14, SSO-8		—	6500	VRMS
Maximum Isolation (Output to Output) (1 s) All Packages		—	1500	VRMS
Maximum Isolation (Input to Output) (1 s) NB SOIC-16, SOIC-8, QFN-14		—	4500	VRMS
<b>Note:</b>				
1. Permanent device damage may occur if the absolute maximum ratings are exceeded. Functional operation should be restricted to the conditions as specified in the operational sections of this data sheet. Exposure to absolute maximum rating conditions for extended periods may affect device reliability.				

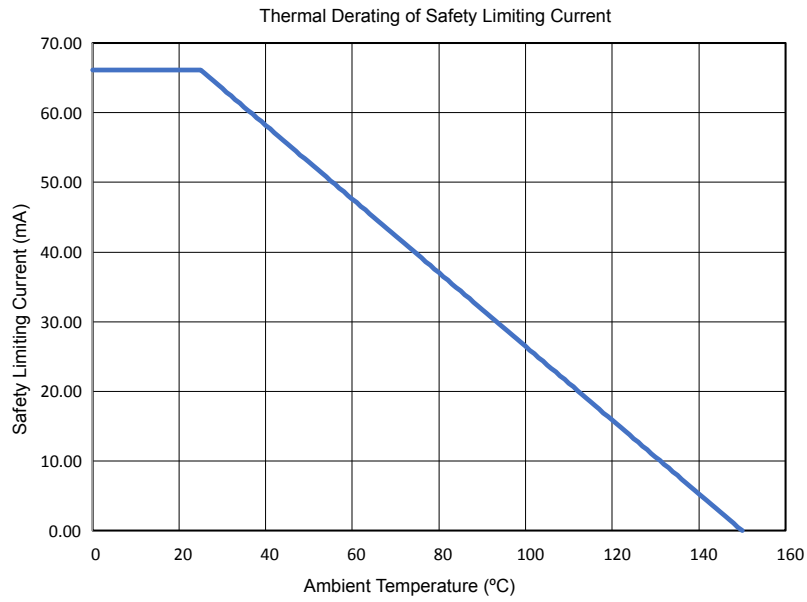

Figure 4.2. NB SOIC-16 Thermal Derating Curve, Dependence of Safety Limiting Values

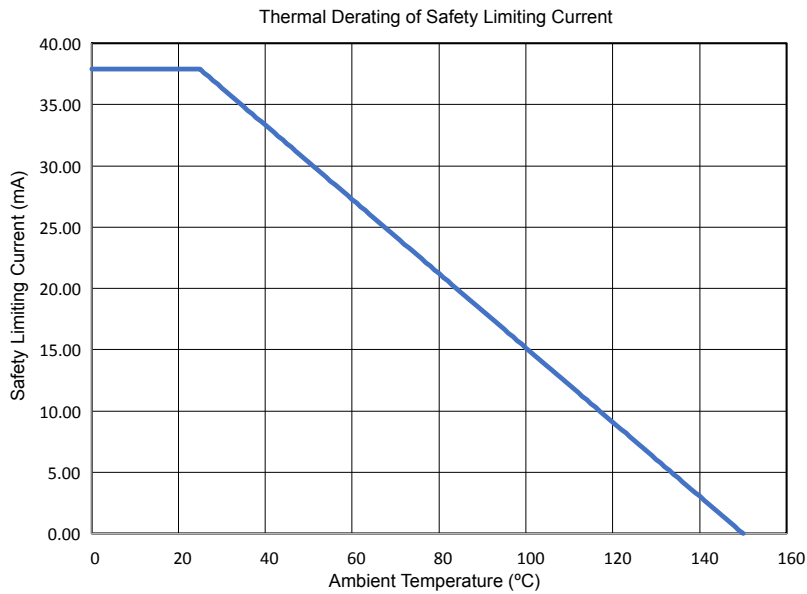

Figure 4.3. NB SOIC-8 Thermal Derating Curve, Dependence of Safety Limiting Values

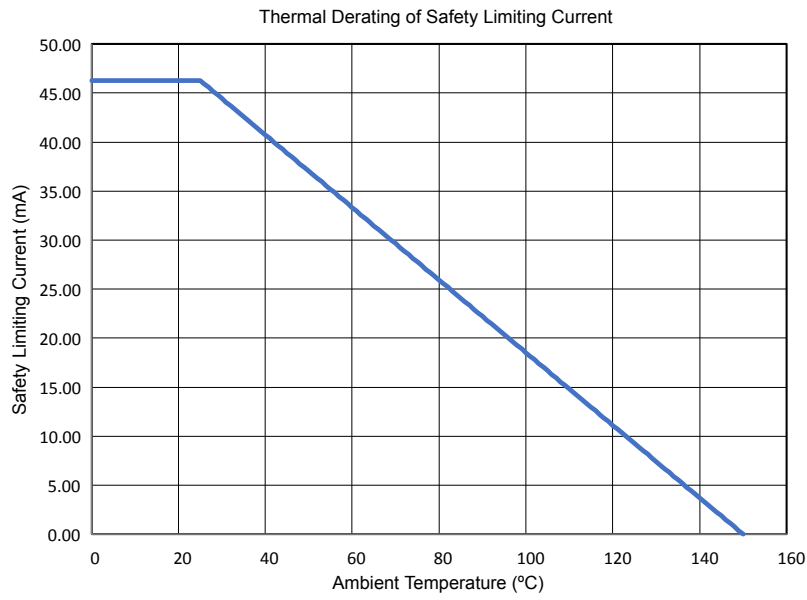

Figure 4.4. SSO-8 Thermal Derating Curve, Dependence of Safety Limiting Values

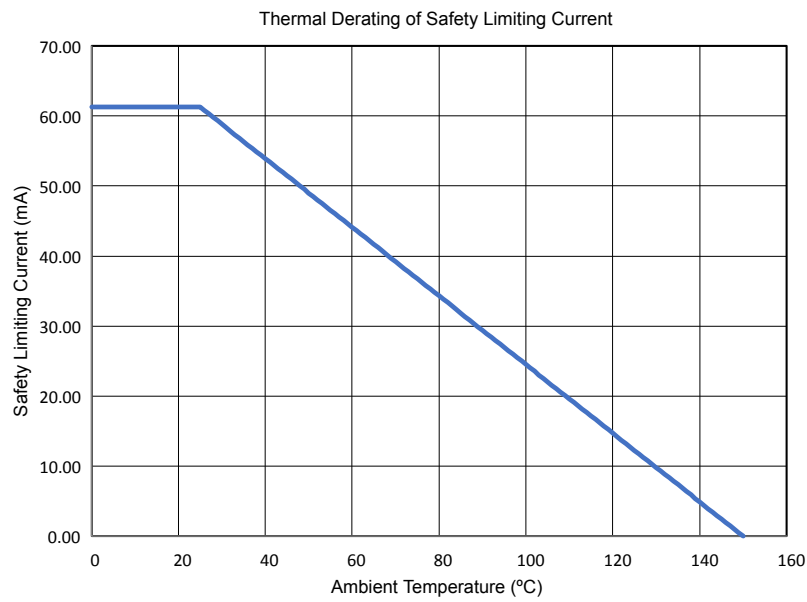

Figure 4.5. WB SOIC-14 Thermal Derating Curve, Dependence of Safety Limiting Values

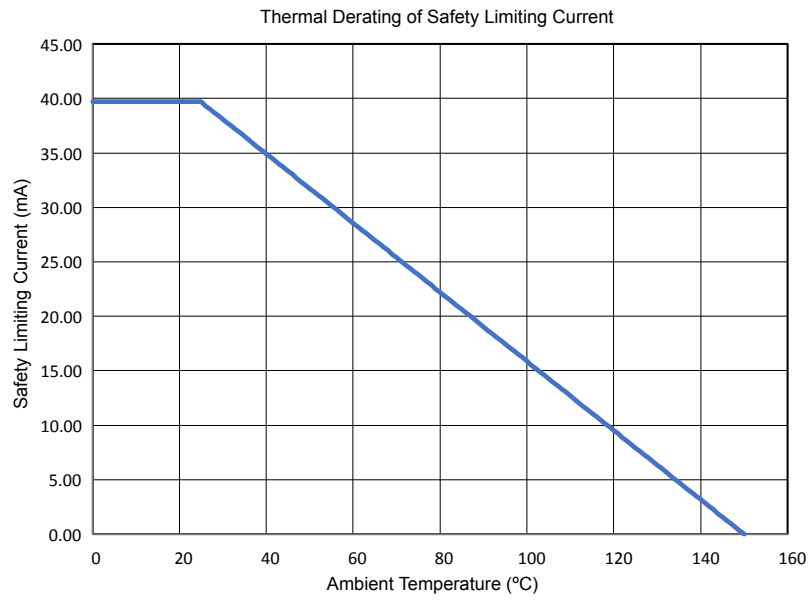

Figure 4.6. QFN-14 Thermal Derating Curve, Dependence of Safety Limiting Values

### 4.1 Typical Operating Characteristics

The typical performance characteristics depicted in this subsection are for information purposes only. Refer to Chapter 4. [Electrical Characteristics](#) for actual specification limits.

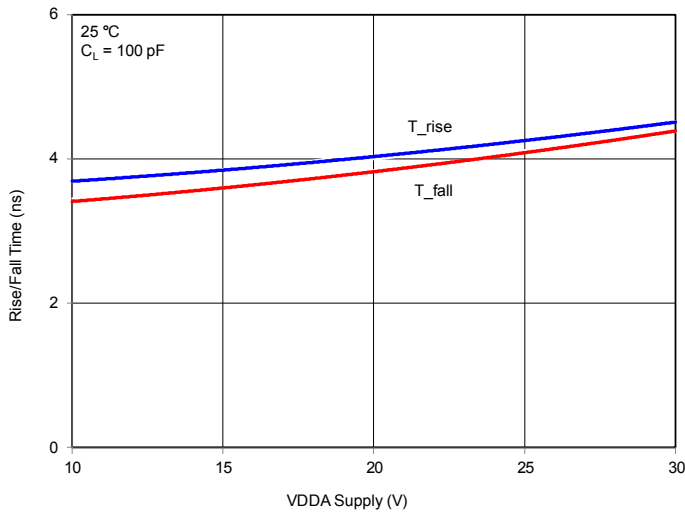

Figure 4.7. Rise/Fall Time vs. Supply Voltage

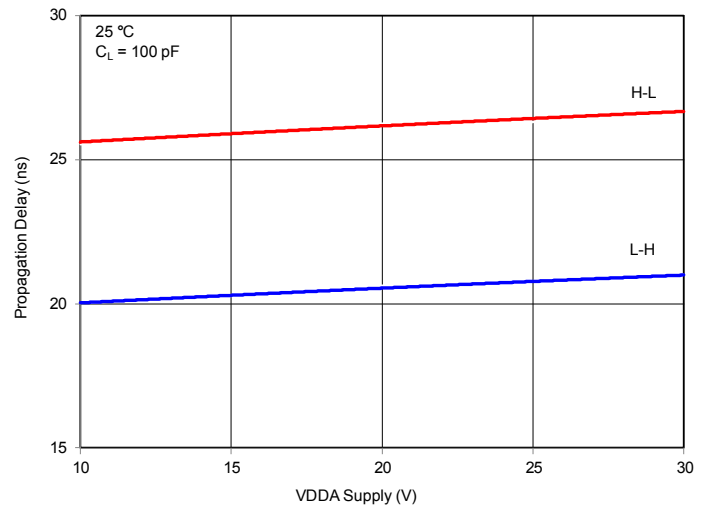

Figure 4.8. Propagation Delay vs. Supply Voltage

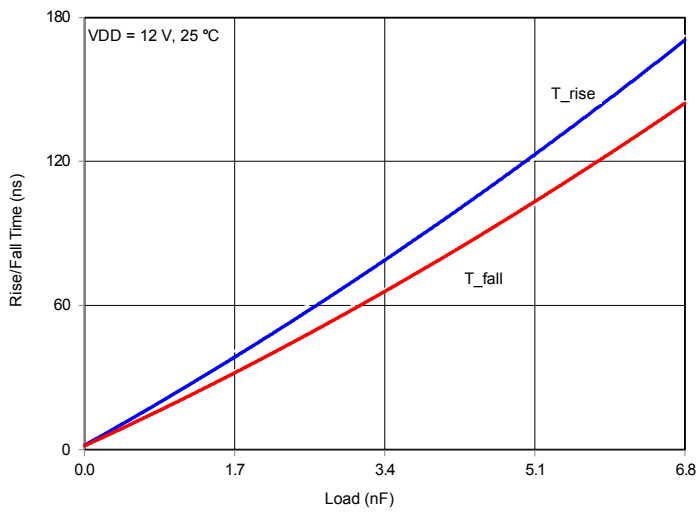

Figure 4.9. Rise/Fall Time vs. Load

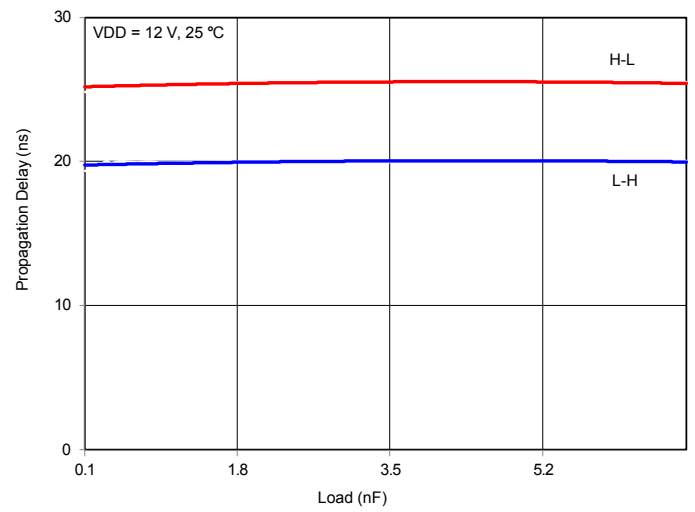

Figure 4.10. Propagation Delay vs. Load

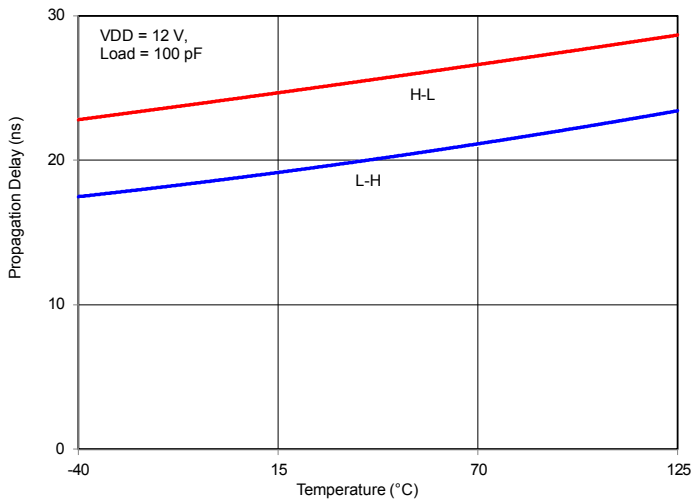

Figure 4.11. Propagation Delay vs. Temperature

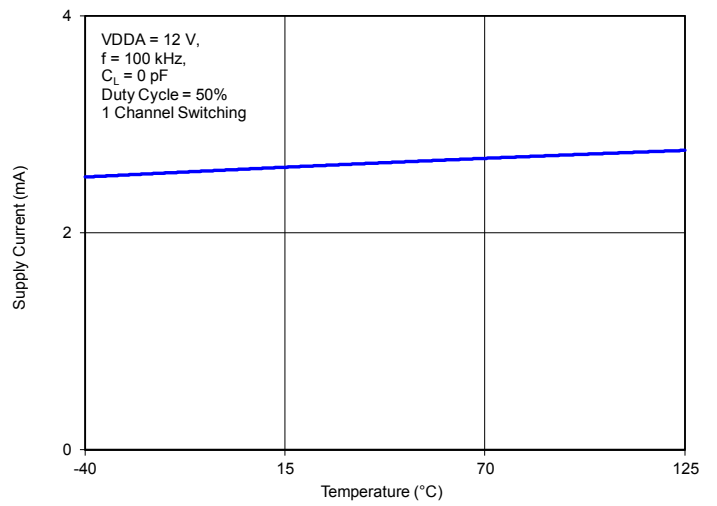

Figure 4.12. Supply Current vs. Temperature

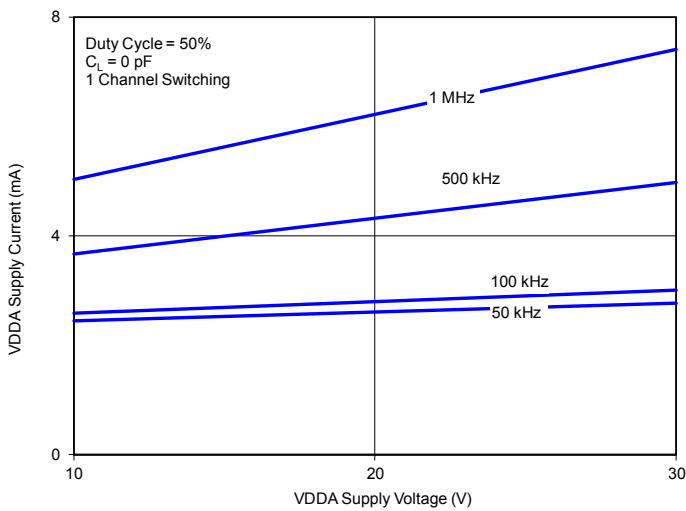

Figure 4.13. Supply Current vs. Supply Voltage ( $C_L = 0$  pF)

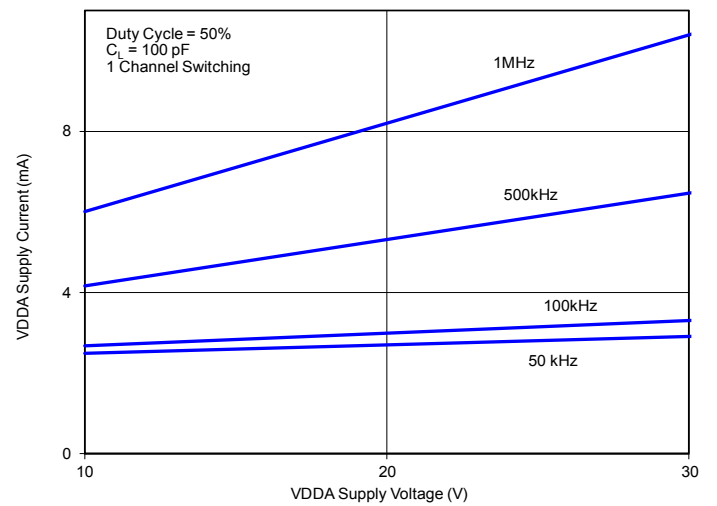

Figure 4.14. Supply Current vs. Supply Voltage ( $C_L = 100$  pF)

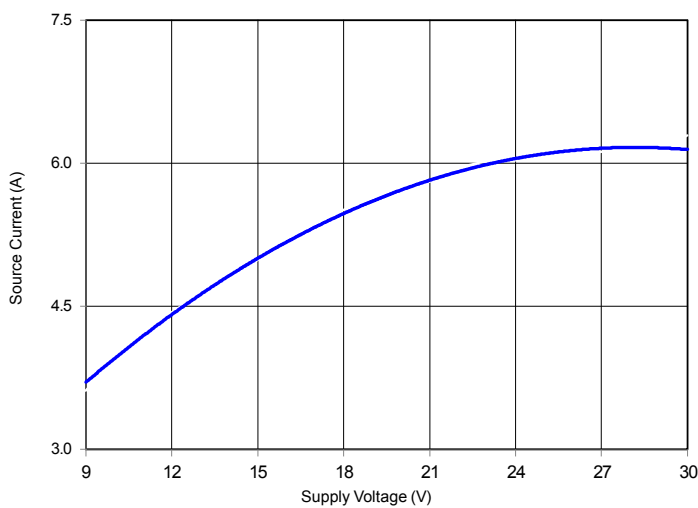

Figure 4.15. Output Source Current vs. Supply Voltage

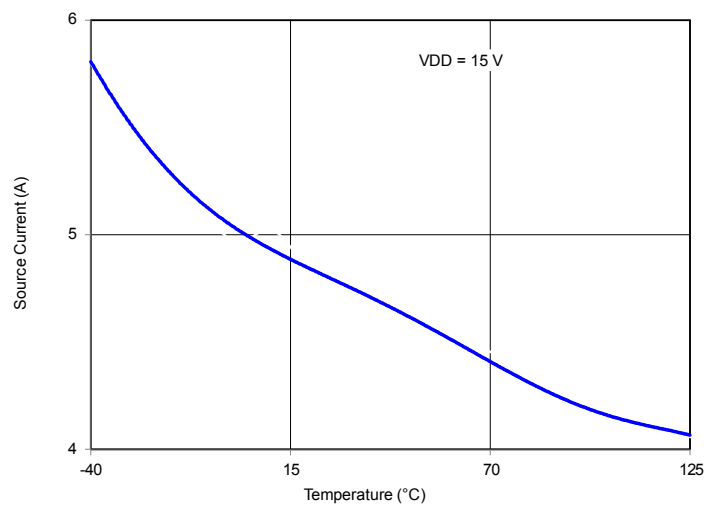

Figure 4.16. Output Source Current vs. Temperature

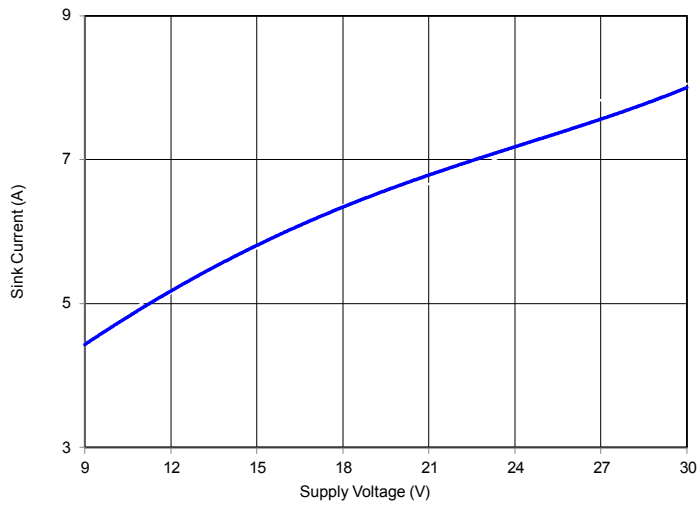

Figure 4.17. Output Sink Current vs. Supply Voltage

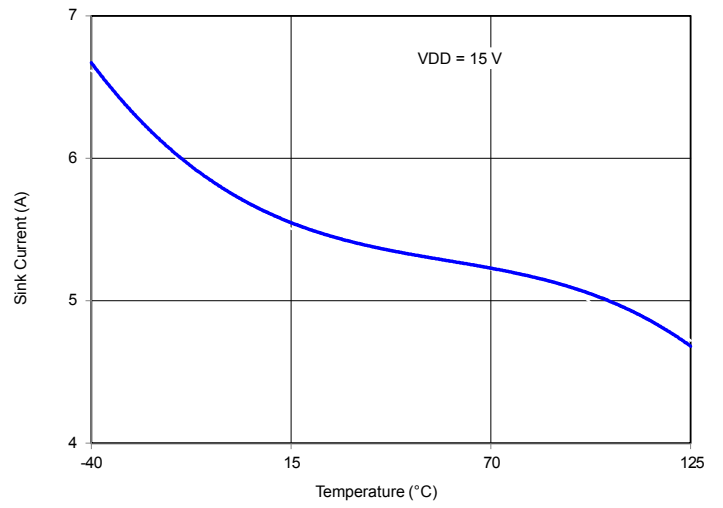

Figure 4.18. Output Sink Current vs. Temperature

## 5. Top-Level Block Diagrams

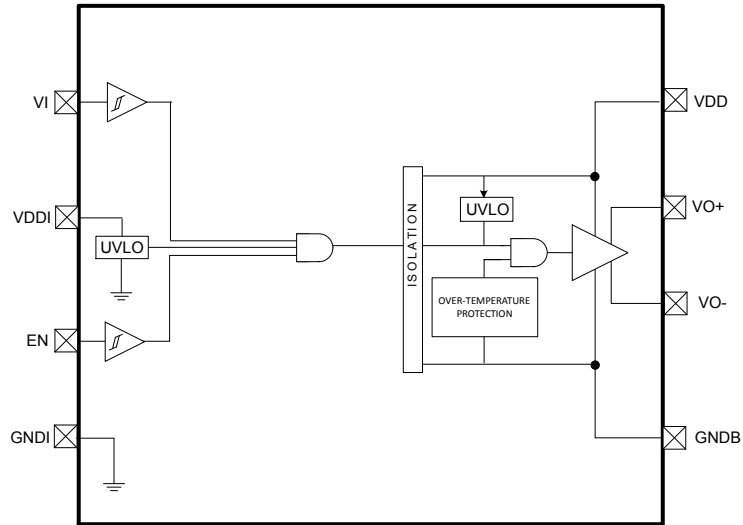

Figure 5.1. Si823H9 Single Isolated Drivers

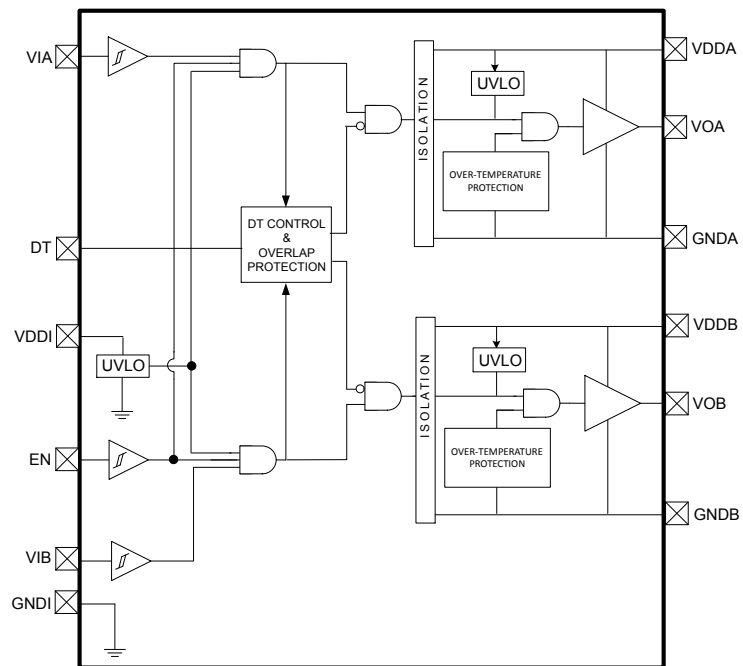

Figure 5.2. Si823H2 HS/LS Isolated Drivers with EN

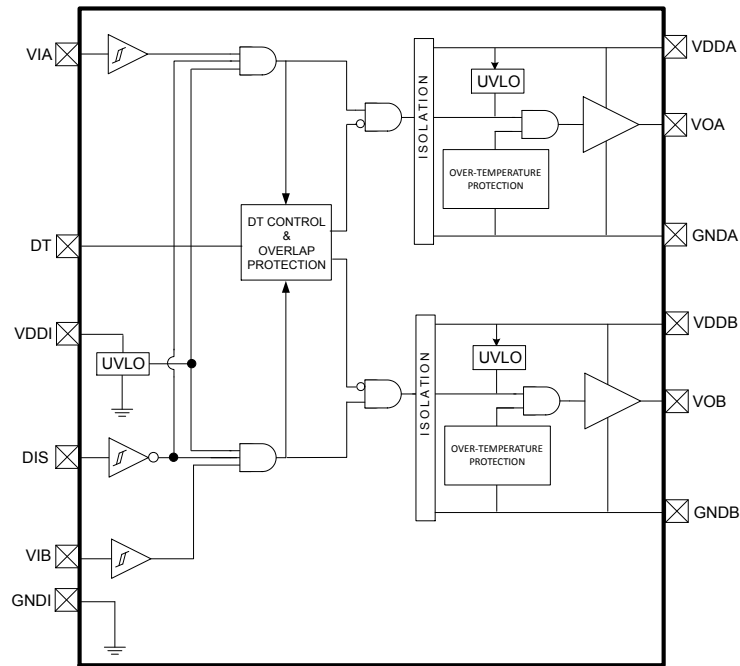

Figure 5.3. Si823H1/3 HS/LS Isolated Drivers with DIS

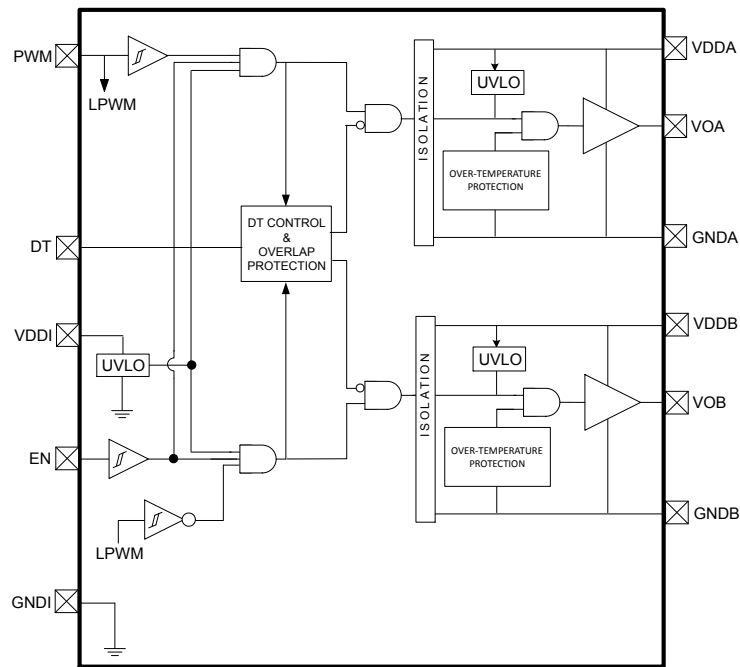

Figure 5.4. Si823H4 Single-Input Isolated Drivers with EN

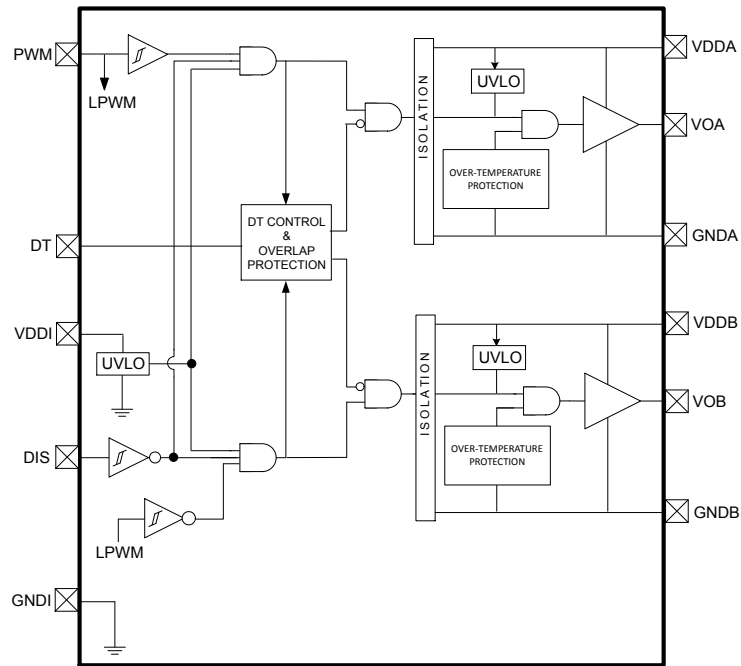

Figure 5.5. Si823H8 Single-Input Isolated Drivers with DIS

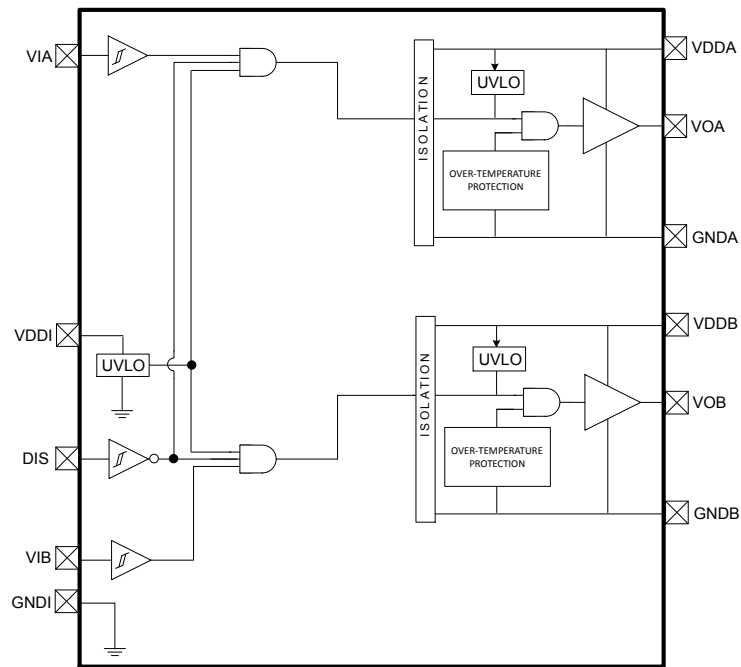

Figure 5.6. Si823H6 Dual Isolated Drivers with DIS

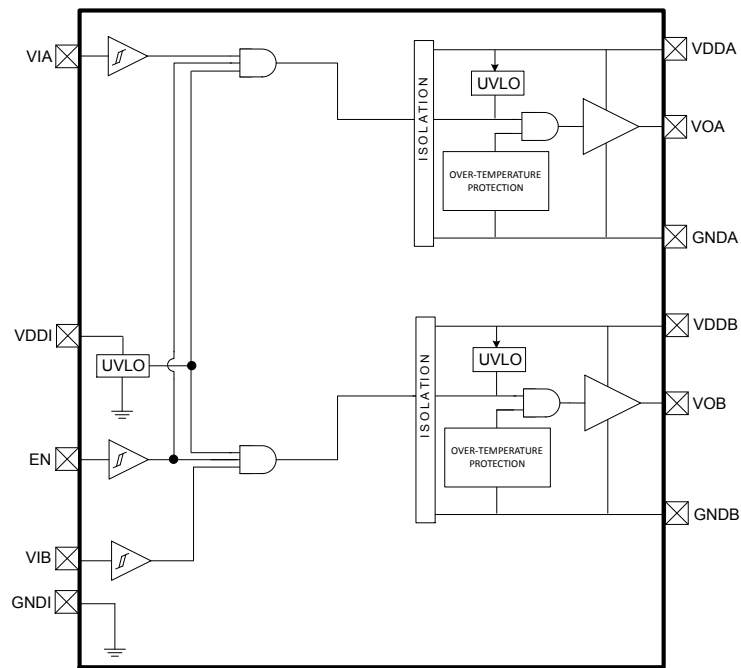

Figure 5.7. Si823H5/7 Dual Isolated Drivers with EN

## 6. Pin Descriptions

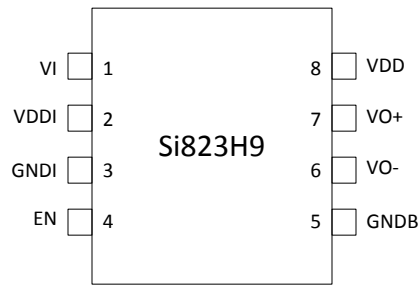

Figure 6.1. Si823H9 SOIC-8 and SSO-8

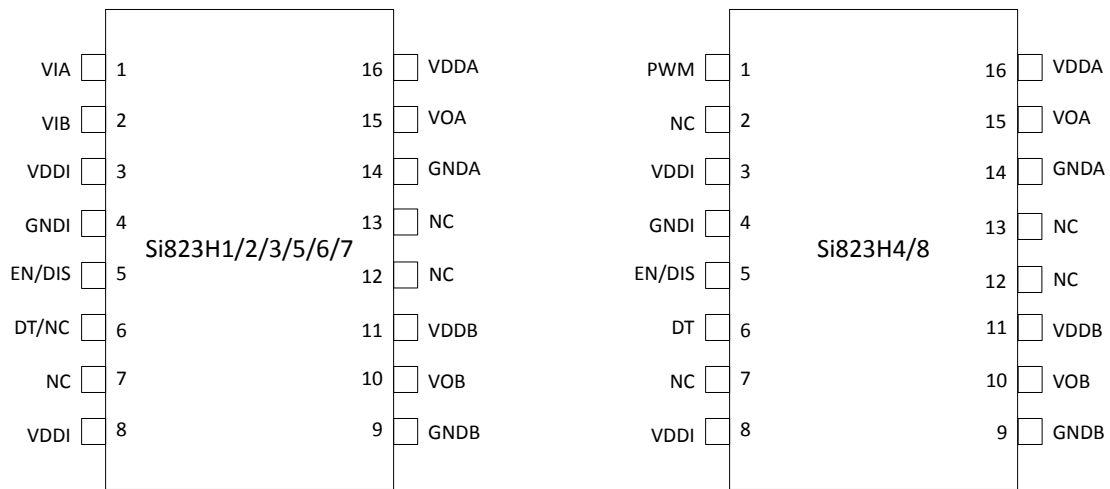

Figure 6.2. Si823Hx SOIC-16 NB

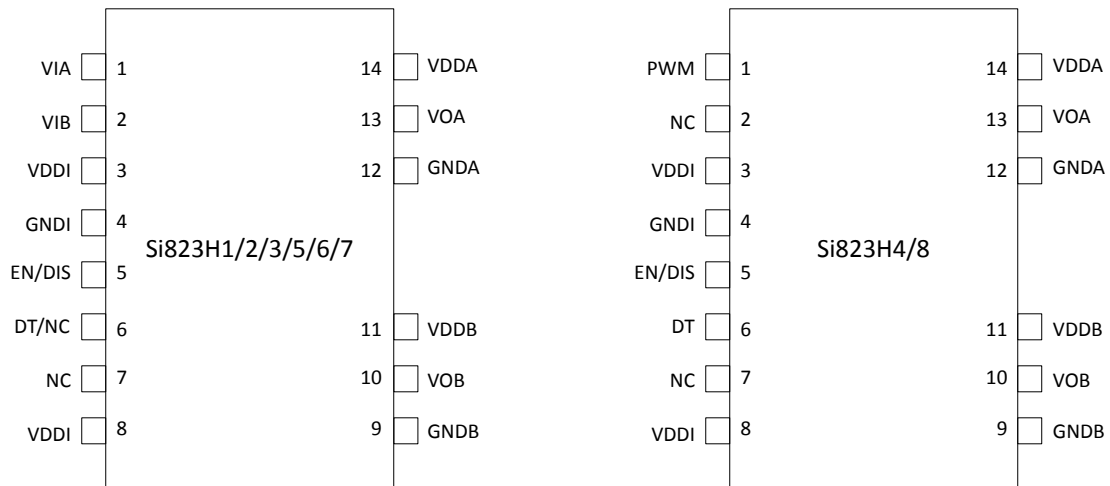

Figure 6.3. Si823Hx SOIC-14 WB

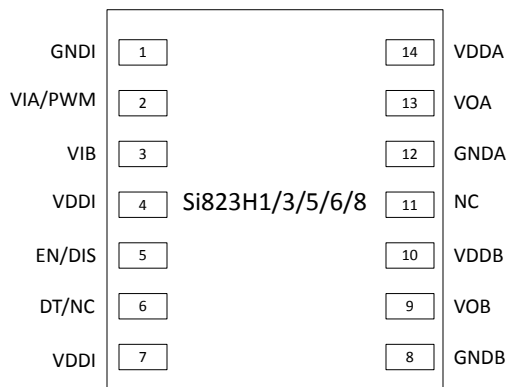

Figure 6.4. Si823Hx QFN-14

Table 6.1. Pin Descriptions

Pin Name	Description
PWM	PWM input
VIA	Non-inverting logic input terminal for Driver A.
VIB	Non-inverting logic input terminal for Driver B.
VDDI	Input-side power supply terminal; connect to a source of 3.0 to 5.5 V.
GNDI	Input-side ground terminal.
EN	Device ENABLE. When asserted, this input enables normal operation of the device. When low or NC, this input unconditionally drives outputs VOA, VOB LOW. When high, device is enabled to perform in normal operating mode. It is strongly recommended that this input be connected to external logic level to avoid erroneous operation due to capacitive noise coupling.
DIS	Device DISABLE. When asserted, this input unconditionally drives outputs VOA, VOB LOW. When low or NC, device is enabled to perform in normal operating mode. It is strongly recommended that this input be connected to external logic level to avoid erroneous operation due to capacitive noise coupling.
DT	Dead time programming input. The value of the resistor connected from DT to ground sets the dead time between output transitions of VOA and VOB.
NC	No connection.
GNDB	Ground terminal for Driver B.
VOB	Driver B output (low-side driver).
VDDB	Driver B power supply voltage terminal; connect to a source of 5.5 to 30 V.
GNDA	Ground terminal for Driver A.
VOA	Driver A output (high-side driver)
VO+	Pull-up output for single driver
VO-	Pull-down output for single driver
VDD	Driver supply for single driver
VDDA	Driver A power supply voltage terminal; connect to a source of 5.5 to 30 V.

## 7. Package Outlines

### 7.1 8-Pin Narrow Body SOIC (SOIC-8)

The figure below illustrates the package details for the Si823Hx in an 8-pin narrow-body SOIC package. The table below lists the values for the dimensions shown in the illustration.

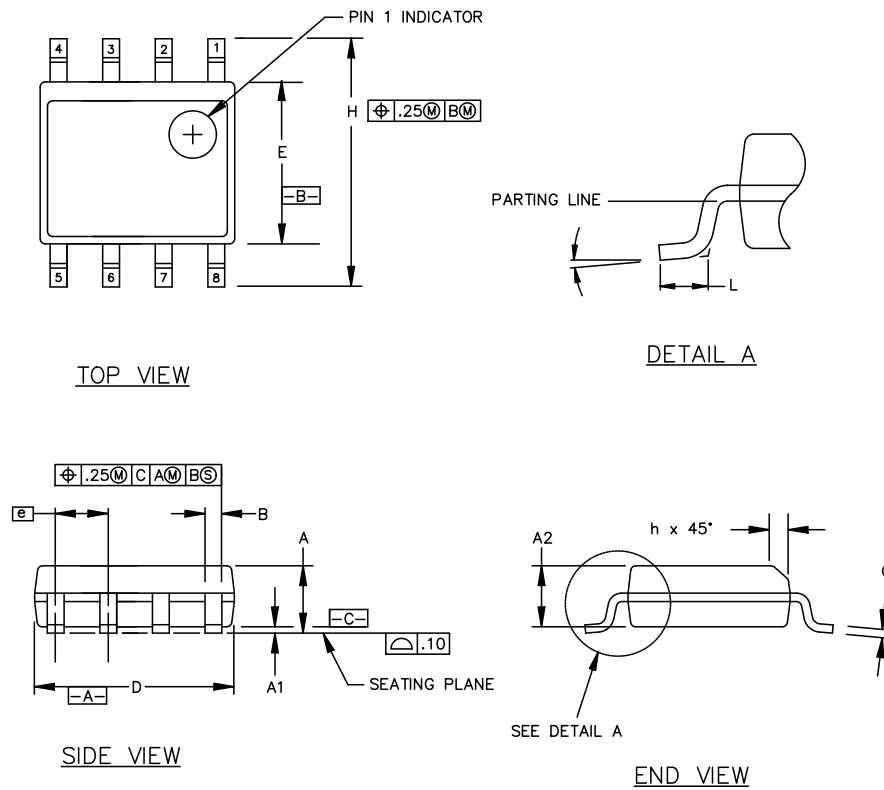

**Figure 7.1. 8-Pin Narrow Body SOIC Package**

**Table 7.1. 8-Pin Narrow Body SOIC Package Diagram Dimensions**

Symbol	Millimeters	
	Min	Max
A	1.35	1.75
A1	0.10	0.25
A2	1.40 REF	1.55 REF
B	0.33	0.51
C	0.19	0.25
D	4.80	5.00
E	3.80	4.00
e	1.27 BSC	
H	5.80	6.20
h	0.25	0.50
L	0.40	1.27
	0°	8°



Dimension	MIN	MAX
bbb	--	0.25
ccc	--	0.10

**Note:**

1. All dimensions shown are in millimeters (mm) unless otherwise noted.
2. Dimensioning and Tolerancing per ANSI Y14.5M-1994.
3. Recommended reflow profile per JEDEC J-STD-020C specification for small body, lead-free components.

**7.3 16-Pin Narrow Body SOIC (SOIC-16 NB)**

The figure below illustrates the package details for the Si823Hx in a 16-pin narrow-body SOIC. The table below lists the values for the dimensions shown in the illustration.

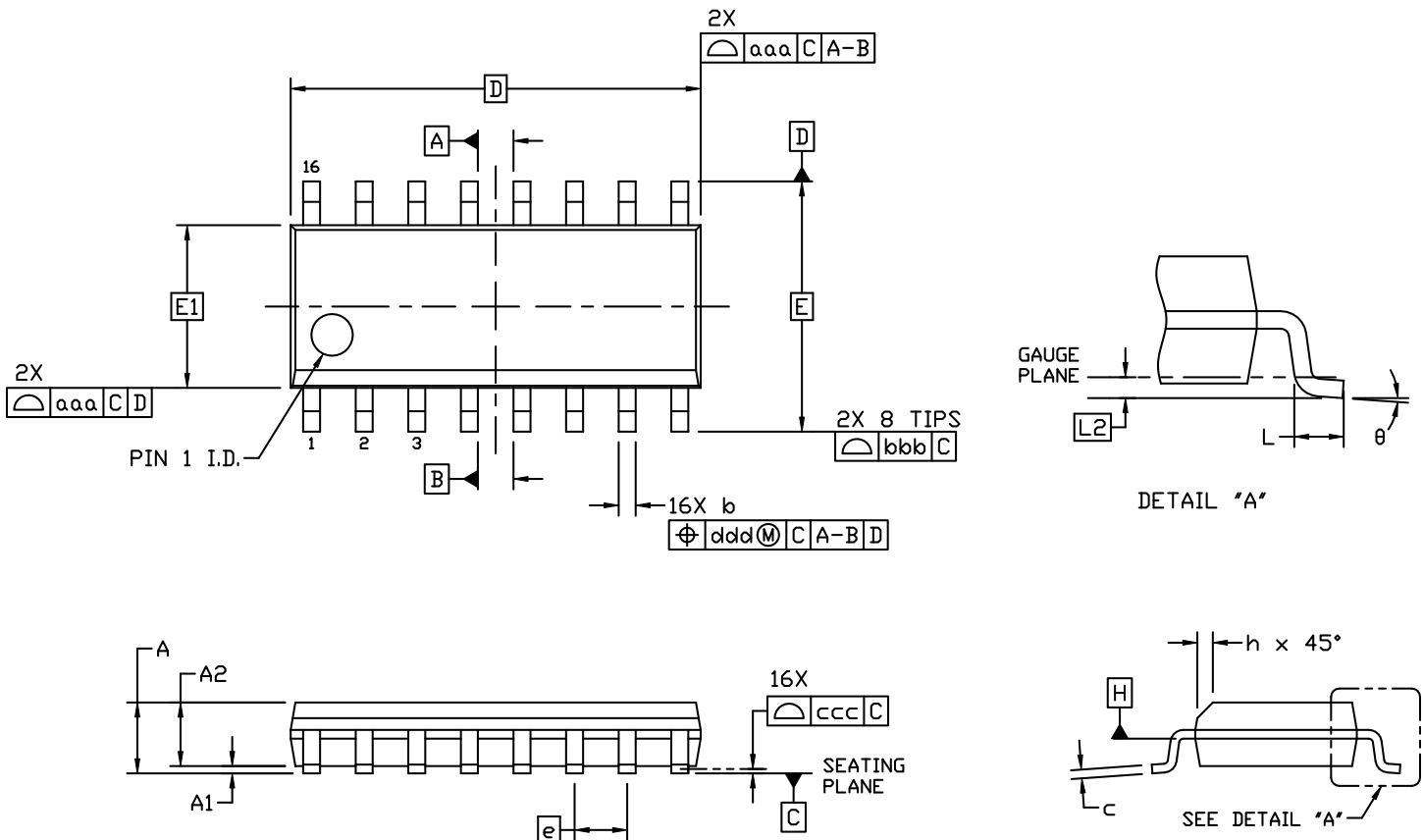

**Figure 7.3. 16-Pin Narrow Body SOIC**

Table 7.3. 16-Pin Narrow Body SOIC Package Diagram Dimensions

Dimension	Min	Max
A	—	1.75
A1	0.10	0.25
A2	1.25	—
b	0.31	0.51
c	0.17	0.25
D	9.90 BSC	
E	6.00 BSC	
E1	3.90 BSC	
e	1.27 BSC	
L	0.40	1.27
L2	0.25 BSC	
h	0.25	0.50
$\theta$	0°	8°
aaa	0.10	
bbb	0.20	
ccc	0.10	
ddd	0.25	

1. All dimensions shown are in millimeters (mm) unless otherwise noted.
2. Dimensioning and Tolerancing per ANSI Y14.5M-1994.
3. This drawing conforms to the JEDEC Solid State Outline MS-012, Variation AC.
4. Recommended card reflow profile is per the JEDEC/IPC J-STD-020 specification for Small Body Components.



## 7.5 14 LD QFN (QFN-14)

The figure below illustrates the package details for the Si823Hx in an QFN outline. The table below lists the values for the dimensions shown in the illustration.

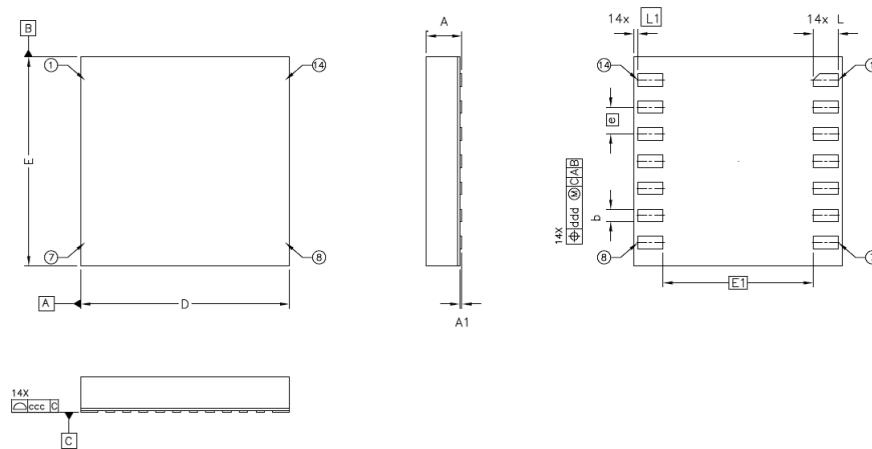

Figure 7.5. Si823Hx 14-pin LD QFN Outline

Table 7.5. Package Diagram Dimensions

Dimension	MIN	NOM	MAX
A	0.74	0.85	0.90
A1	0	0.025	0.05
b	0.25	0.30	0.35
D	5.00 BSC		
e	0.65 BSC		
E	5.00 BSC		
E1	3.60 BSC		
L	0.50	0.60	0.70
L1 <sup>3</sup>	—	0.10 BSC	—
ccc	—	—	0.08
ddd	—	—	0.10

### Notes:

1. All dimensions shown are in millimeters (mm) unless otherwise noted.
2. Dimensioning and Tolerancing per ANSI Y14.5M-1994.
3. L1 shall not be less than 0.01 mm.

## 8. Land Patterns

### 8.1 8-Pin Narrow Body SOIC

The figure below illustrates the recommended land pattern details for the Si823Hx in an 8-pin narrow-body SOIC. The table below lists the values for the dimensions shown in the illustration.

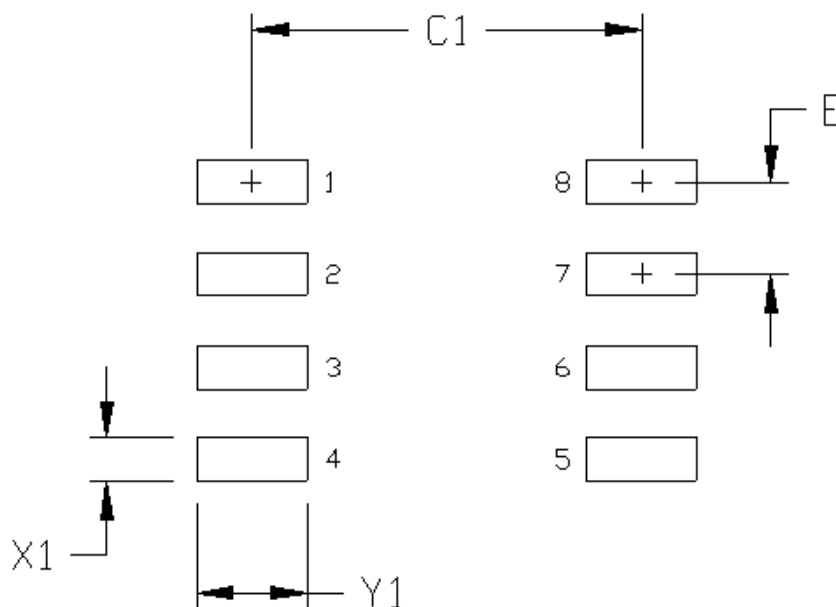

Figure 8.1. 8-Pin Narrow Body SOIC Land Pattern

Table 8.1. 8-Pin Narrow Body SOIC Land Pattern Dimensions

Dimension	Feature	(mm)
C1	Pad Column Spacing	5.40
E	Pad Row Pitch	1.27
X1	Pad Width	0.60
Y1	Pad Length	1.55

**Notes:**

1. This Land Pattern Design is based on IPC-7351 pattern SOIC127P600X173-8N for Density Level B (Median Land Protrusion).
2. All feature sizes shown are at Maximum Material Condition (MMC) and a card fabrication tolerance of 0.05 mm is assumed.

## 8.2 8-Pin Wide Body Stretched SOIC

The figure below illustrates the recommended land pattern details for the Si823Hx in a 8-Pin Wide Body Stretched SOIC package. The table lists the values for the dimensions shown in the illustration.

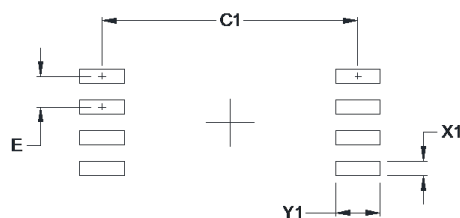

Figure 8.2. 8-Pin Wide Body Stretched SOIC Land Pattern

Table 8.2. 8-Pin Wide Body Stretched SOIC Land Pattern Dimensions

Symbol	mm
C1	10.60
E	1.27
X1	0.60
Y1	1.85

### Note:

#### General

1. All dimensions shown are at Maximum Material Condition (MMC). Least Material Condition (LMC) is calculated based on a Fabrication Allowance of 0.05 mm.
2. This Land Pattern Design is based on the IPC-7351 guidelines.

#### Solder Mask Design

1. All metal pads are to be non-solder mask defined (NSMD). Clearance between the solder mask and the metal pad is to be 60µm minimum, all the way around the pad.

#### Stencil Design

1. A stainless steel, laser-cut and electro-polished stencil with trapezoidal walls should be used to assure good solder paste release.
2. The stencil thickness should be 0.125 mm (5 mils).
3. The ratio of stencil aperture to land pad size should be 1:1 for all perimeter pins.

#### Card Assembly

1. A No-Clean, Type-3 solder paste is recommended.
2. The recommended card reflow profile is per the JEDEC/IPC J-STD-020 specification for Small Body Components.

### 8.3 16-Pin Narrow Body SOIC

The figure below illustrates the recommended land pattern details for the Si823Hx in a 16-pin Narrow Body SOIC. The table lists the values for the dimensions shown in the illustration.

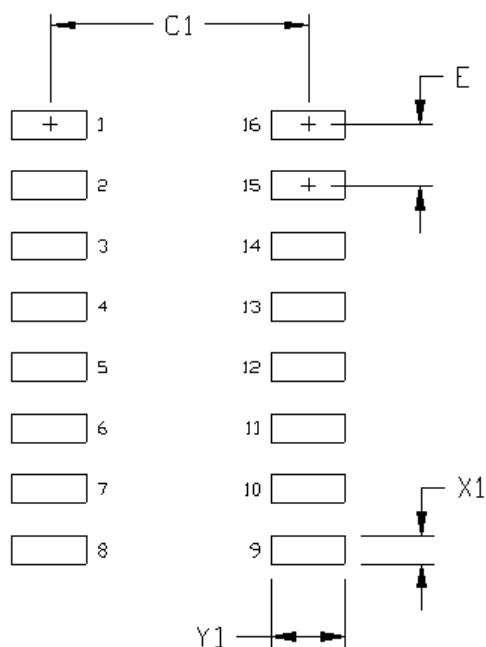

Figure 8.3. 16-Pin Narrow Body SOIC PCB Land Pattern

Table 8.3. 16-Pin Narrow Body SOIC Land Pattern Dimensions

Dimension	Feature	(mm)
C1	Pad Column Spacing	5.40
E	Pad Row Pitch	1.27
X1	Pad Width	0.60
Y1	Pad Length	1.55

**Note:**

1. This Land Pattern Design is based on IPC-7351 pattern SOIC127P600X165-16N for Density Level B (Median Land Protrusion).
2. All feature sizes shown are at Maximum Material Condition (MMC) and a card fabrication tolerance of 0.05 mm is assumed.

## 8.4 14-Pin Wide Body SOIC

The figure below illustrates the recommended land pattern details for the Si823Hx in a 14-pin Wide Body SOIC. The table lists the values for the dimensions shown in the illustration.

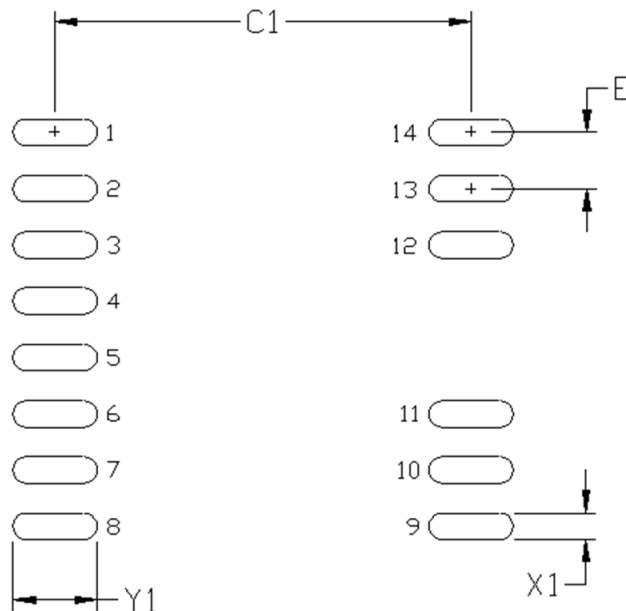

Figure 8.4. 14-Pin WB SOIC Land Pattern

Table 8.4. 14-Pin WB SOIC Land Pattern Dimensions

Dimension	Feature	(mm)
C1	Pad Column Spacing	9.70
E	Pad Row Pitch	1.27
X1	Pad Width	0.60
Y1	Pad Length	1.60

**Notes:**

1. This Land Pattern Design is based on IPC-7351 pattern SOIC127P1032X265-16AN for Density Level B (Median Land Protrusion).
2. All feature sizes shown are at Maximum Material Condition (MMC) and a card fabrication tolerance of 0.05 mm is assumed.

## 8.5 14 LD QFN

The figure below illustrates the recommended land pattern details for the Si823Hx in a 14-pin LD QFN. The table below lists the values for the dimensions shown in the illustration.

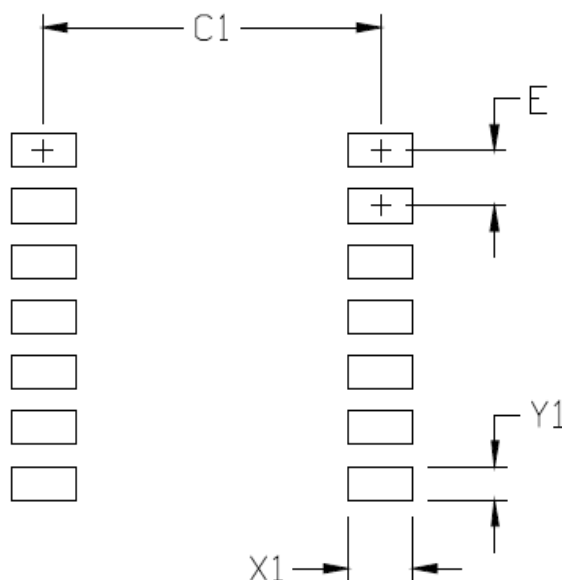

Figure 8.5. 14-Pin LGA/QFN Land Pattern

Table 8.5. 14-Pin LD QFN Land Pattern Dimensions

Dimension	(mm)
C1	4.20
E	0.65
X1	0.80
Y1	0.40

### Notes:

#### General

1. All dimensions shown are in millimeters (mm).
2. This Land Pattern Design is based on the IPC-7351 guidelines.
3. All dimensions shown are at Maximum Material Condition (MMC). Least Material Condition (LMC) is calculated based on a Fabrication Allowance of 0.05 mm.

#### Solder Mask Design

1. All metal pads are to be non-solder mask defined (NSMD). Clearance between the solder mask and the metal pad is to be 60  $\mu\text{m}$  minimum, all the way around the pad.

#### Stencil Design

1. A stainless steel, laser-cut and electro-polished stencil with trapezoidal walls should be used to assure good solder paste release.
2. The stencil thickness should be 0.125 mm (5 mils).
3. The ratio of stencil aperture to land pad size should be 1:1.

#### Card Assembly

1. A No-Clean, Type-3 solder paste is recommended.
2. The recommended card reflow profile is per the JEDEC/IPC J-STD-020 specification for Small Body Components.

## 9. Top Markings

### 9.1 8-Pin Narrow Body SOIC

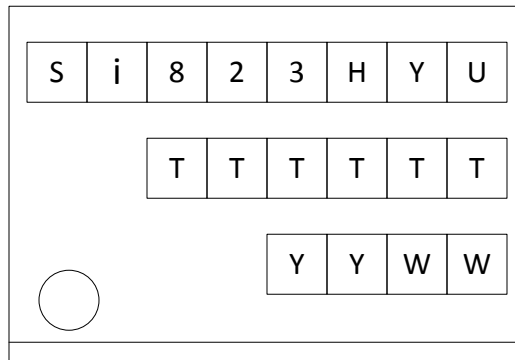

**Table 9.1. Top Marking Explanation (8-Pin Narrow Body SOIC)**

<b>Line 1 Marking:</b>	Base Part Number Ordering Options See <a href="#">1. Ordering Guide</a> for more information.	Si823H = ISOdriver product series Y = Output configuration: <ul style="list-style-type: none"> <li>• 9 = Single driver</li> </ul> U = UVLO level: A, B, C <ul style="list-style-type: none"> <li>• A = 6 V</li> <li>• B = 8 V</li> <li>• C = 12 V</li> </ul>
<b>Line 2 Marking:</b>	TTTTTT = Mfg Code	Manufacturing Code from Assembly Purchase Order form.
<b>Line 3 Marking:</b>	YY = Year WW = Workweek	Assigned by the Assembly House. Corresponds to the year and workweek of the mold date.

## 9.2 8-Pin Wide Body Stretched SOIC

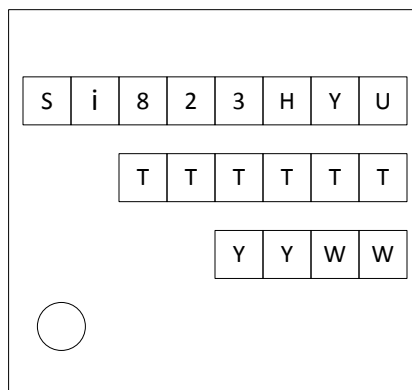
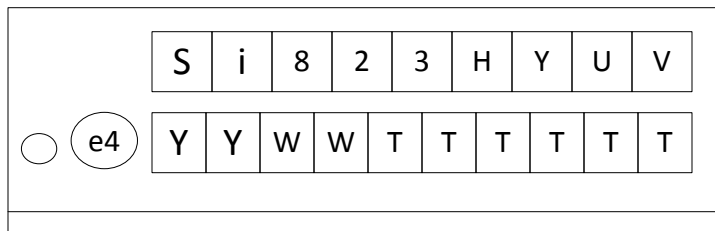

Table 9.2. Top Marking Explanation (8-Pin Wide Body Stretched SOIC)

<b>Line 1 Marking:</b>	Base Part Number Ordering Options See <a href="#">1. Ordering Guide</a> for more information.	Si823H = ISOdriver product series Y = Output configuration: • 9 = Single driver U = UVLO level: A, B, C • A = 6 V • B = 8 V • C = 12 V
<b>Line 2 Marking:</b>	TTTTTT = Mfg Code	Manufacturing Code from Assembly Purchase Order form.
<b>Line 3 Marking:</b>	YY = Year WW = Workweek	Assigned by the Assembly House. Corresponds to the year and workweek of the mold date.

**9.3 16-Pin Narrow Body SOIC**



**Table 9.3. Top Marking Explanation (16-Pin Narrow Body SOIC)**

<p><b>Line 1 Marking:</b></p>	<p>Base Part Number Ordering Options                  See <a href="#">1. Ordering Guide</a> for more information.</p>	<p>Si823H = ISOdriver product series</p> <p>Y = Output configuration: 1, 2,3, 4, 5, 6, 7, 8</p> <ul style="list-style-type: none"> <li>• 1 = HS LS, VIA/VIB with a DIS pin</li> <li>• 2 = HS LS, VIA/VIB with an EN pin</li> <li>• 3 = HS LS, VIA/VIB with a DIS pin &amp; de-glitch</li> <li>• 4 = PWM, HS/LS, EN pin</li> <li>• 5 = Dual driver, EN pin</li> <li>• 6 = Dual driver, DIS pin</li> <li>• 7 = Dual driver, delayed startup time, EN pin</li> <li>• 8 = PWM, HS/LS, DIS pin</li> </ul> <p>U = UVLO level: A, B, C</p> <ul style="list-style-type: none"> <li>• A = 6 V</li> <li>• B = 8 V</li> <li>• C = 12 V</li> </ul> <p>V = Isolation rating:</p> <ul style="list-style-type: none"> <li>• B = 2.5 kV</li> </ul>
<p><b>Line 2 Marking:</b></p>	<p>YY = Year                  WW = Workweek                  TTTTTT = Mfg Code                  e4 circle is 1.3 mm diameter</p>	<p>Assigned by the Assembly House. Corresponds to the year and workweek of the mold date.</p> <p>Manufacturing Code from Assembly Purchase Order form.</p> <p>e4 is Pb-Free Symbol</p>

## 9.4 14-Pin Wide Body SOIC

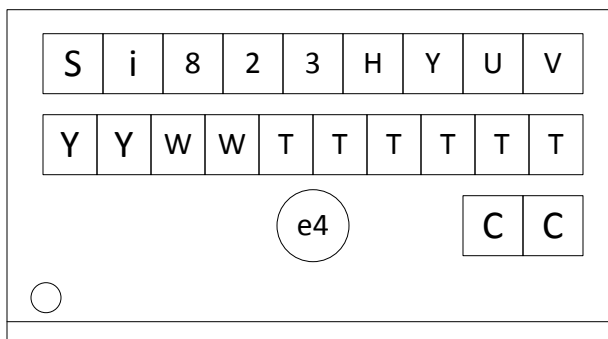

Table 9.4. Top Marking Explanation (14-Pin Wide Body SOIC)

<b>Line 1 Marking:</b>	Base Part Number Ordering Options See <a href="#">1. Ordering Guide</a> for more information.	Si823H = ISOdriver product series Y = Output configuration: 1, 2,3, 4, 5, 6, 7, 8 <ul style="list-style-type: none"> <li>• 1 = HS LS, VIA/VIB with a DIS pin</li> <li>• 2 = HS LS, VIA/VIB with an EN pin</li> <li>• 3 = HS LS, VIA/VIB with a DIS pin &amp; de-glitch</li> <li>• 4 = PWM, HS/LS, EN pin</li> <li>• 5 = Dual driver, EN pin</li> <li>• 6 = Dual driver, DIS pin</li> <li>• 7 = Dual driver, delayed startup time, EN pin</li> <li>• 8 = PWM, HS/LS, DIS pin</li> </ul> U = UVLO level: A, B, C (applies to both product series) <ul style="list-style-type: none"> <li>• A = 6 V</li> <li>• B = 8 V</li> <li>• C = 12 V</li> </ul> V = Isolation rating: <ul style="list-style-type: none"> <li>• D = 5.0 kV</li> </ul>
<b>Line 2 Marking:</b>	YY = Year WW = Workweek TTTTTT = Mfg Code	Assigned by the Assembly House. Corresponds to the year and workweek of the mold date. Manufacturing Code from Assembly Purchase Order form.
<b>Line 3 Marking:</b>	Circle = 1.5 mm Diameter (Center Justified) Country of Origin ISO Code Abbreviation e4 circle is 1.7 mm diameter	"e4" Pb-Free Symbol TW = Taiwan e4 is Pb-Free Symbol

## 9.5 14 LD QFN

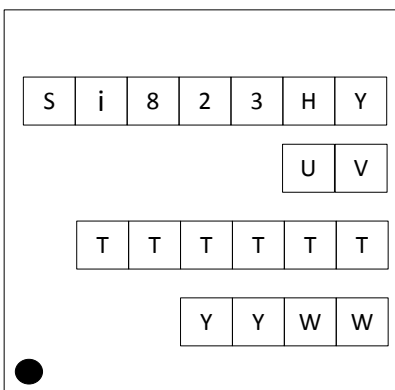

Table 9.5. Top Marking Explanation (14-Pin QFN)

<b>Line 1 Marking:</b>	Base Part Number Ordering Options  See <a href="#">1. Ordering Guide</a> for more information.	Si823H = ISOdriver product series Y = Output configuration: 0, 1, 2,3, 4, 5, 6, 7, 8 <ul style="list-style-type: none"> <li>• 1 = HS LS, VIA/VIB with a DIS pin</li> <li>• 2 = HS LS, VIA/VIB with an EN pin</li> <li>• 3 = HS LS, VIA/VIB with a DIS pin &amp; de-glitch</li> <li>• 4 = PWM, HS/LS, EN pin</li> <li>• 5 = Dual driver, EN pin</li> <li>• 6 = Dual driver, DIS pin</li> <li>• 7 = Dual driver, delayed startup time, EN pin</li> <li>• 8 = PWM, HS/LS, DIS pin</li> </ul>
<b>Line 2 Marking:</b>	Ordering Options	U = UVLO level: A, B, C <ul style="list-style-type: none"> <li>• A = 6 V</li> <li>• B = 8 V</li> <li>• C = 12 V</li> </ul> V = Isolation rating <ul style="list-style-type: none"> <li>• B = 2.5 kV</li> </ul>
<b>Line 3 Marking:</b>	TTTTTT = Mfg Code	Manufacturing Code from Assembly Purchase Order form.
<b>Line 4 Marking:</b>	YY = Year  WW = Workweek	Assigned by the Assembly House. Corresponds to the year and workweek of the mold date.

## 10. Revision History

### 10.1 Revision 0.61

- January 2020
  - Updated [Table 1.2 Ordering Guide for Automotive Grade OPNs on page 4](#).

### 10.2 Revision 0.6

- December 2019
  - Updated Ordering Guide.
  - Updated [7.4 14-Pin Wide Body SOIC \(SOIC-14 WB\)](#).

### 10.3 Revision 0.5

- 13 June 2019
  - Updated Application Diagrams and Top-Level Block Diagrams.
  - Added Ordering Guide for Automotive Grade OPNs.

### 10.4 Revision 0.34

- 08 January 2019
  - Added OPN Si823H8BB-IM1.

### 10.5 Revision 0.33

- 04 December 2018
  - Separated Si825xx OPNs from this datasheet.
  - Labeled 2.5 kVrms and 3.75 kVrms products as "Available Now" and 5 kVrms as "Sampling Now".
  - Added Section 2.13 Driver Output Booster Function Description.
  - Added NB SOIC-16 package.

### 10.6 Revision 0.1

- 26 July 2017
  - Initial release.

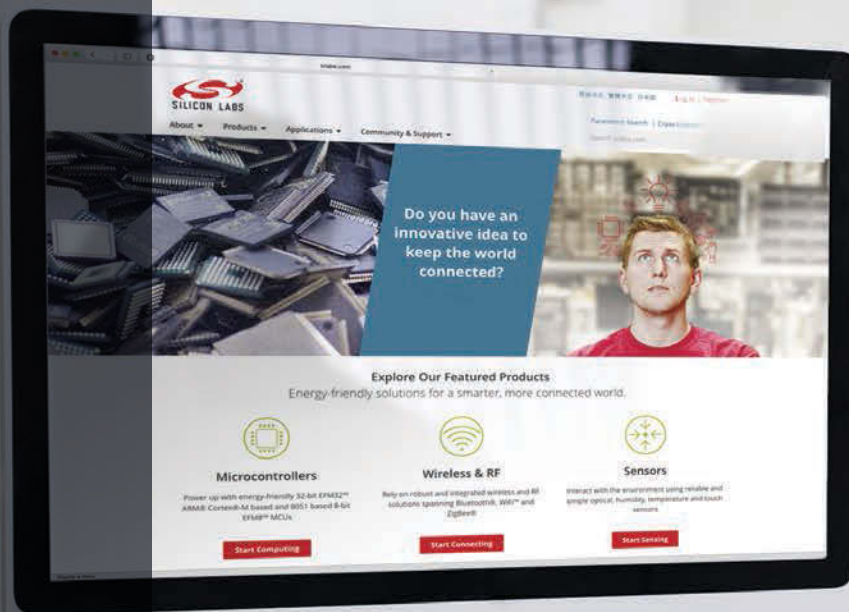

Smart.  
Connected.  
Energy-Friendly.



**Products**  
[www.silabs.com/products](http://www.silabs.com/products)

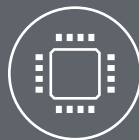

**Quality**  
[www.silabs.com/quality](http://www.silabs.com/quality)



**Support and Community**  
[community.silabs.com](http://community.silabs.com)

**Disclaimer**

Silicon Labs intends to provide customers with the latest, accurate, and in-depth documentation of all peripherals and modules available for system and software implementers using or intending to use the Silicon Labs products. Characterization data, available modules and peripherals, memory sizes and memory addresses refer to each specific device, and "Typical" parameters provided can and do vary in different applications. Application examples described herein are for illustrative purposes only. Silicon Labs reserves the right to make changes without further notice to the product information, specifications, and descriptions herein, and does not give warranties as to the accuracy or completeness of the included information. Without prior notification, Silicon Labs may update product firmware during the manufacturing process for security or reliability reasons. Such changes will not alter the specifications or the performance of the product. Silicon Labs shall have no liability for the consequences of use of the information supplied in this document. This document does not imply or expressly grant any license to design or fabricate any integrated circuits. The products are not designed or authorized to be used within any FDA Class III devices, applications for which FDA premarket approval is required, or Life Support Systems without the specific written consent of Silicon Labs. A "Life Support System" is any product or system intended to support or sustain life and/or health, which, if it fails, can be reasonably expected to result in significant personal injury or death. Silicon Labs products are not designed or authorized for military applications. Silicon Labs products shall under no circumstances be used in weapons of mass destruction including (but not limited to) nuclear, biological or chemical weapons, or missiles capable of delivering such weapons. Silicon Labs disclaims all express and implied warranties and shall not be responsible or liable for any injuries or damages related to use of a Silicon Labs product in such unauthorized applications.

**Trademark Information**

Silicon Laboratories Inc.®, Silicon Laboratories®, Silicon Labs®, SiLabs® and the Silicon Labs logo®, Bluegiga®, Bluegiga Logo®, ClockBuilder®, CMEMS®, DSPLL®, EFM®, EFM32®, EFR®, Ember®, Energy Micro, Energy Micro logo and combinations thereof, "the world's most energy friendly microcontrollers", Ember®, EZLink®, EZRadio®, EZRadioPRO®, Gecko®, Gecko OS, Gecko OS Studio, ISOModem®, Precision32®, ProSLIC®, Simplicity Studio®, SiPHY®, Telegesis, the Telegesis Logo®, USBXpress®, Zentri, the Zentri logo and Zentri DMS, Z-Wave®, and others are trademarks or registered trademarks of Silicon Labs. ARM, CORTEX, Cortex-M3 and THUMB are trademarks or registered trademarks of ARM Holdings. Keil is a registered trademark of ARM Limited. Wi-Fi is a registered trademark of the Wi-Fi Alliance. All other products or brand names mentioned herein are trademarks of their respective holders.



Silicon Laboratories Inc.  
400 West Cesar Chavez  
Austin, TX 78701  
USA

<http://www.silabs.com>