



Si53350/58/54/52 Data Sheet

10/8/4/2-Output Clock Buffer

The Si5335x universal and pin-selectable format devices are the industry's highest performance and lowest power automotive grade fanout buffers. The devices are offered in 10, 8, 4, and 2-output options, supporting both differential and single-ended output formats. These devices feature typical 120 fs additive phase jitter characteristics, operating over a frequency range of 10-250 MHz. Built-in LDOs deliver high PSNR performance and reduce the need for external components, simplifying low-jitter clock distribution in noisy environments.

The Si5335x family are available in both pin selectable input/output format versions as well as fully customizable versions where input/output formats and input hardware pins can be defined using ClockBuilder Pro to match exact system requirements. Using ClockBuilder Pro, users can define the signal format on each output individually, enable a 2:1 input mux, define input/output voltage translation. In addition to those features, an LOS monitor of input clocks can be enabled.

Applications:

- Infotainment
- ADAS
- Radar Sensors
- Automated Driving Processing Unit
- Networking Gateways

KEY FEATURES

- 10, 8, 4, 2-output ordering options
- Loss of signal (LOS) monitors for loss of input clock
- AEC-Q100 qualified
- AEC-Q006 qualified
- Automotive grade 2: -40 to +105 °C
- 10 - 250 MHz frequency range
- Fully customizable configurations using ClockBuilder Pro
- Excellent additive jitter performance
 - 120 fs RMS, 156.25 MHz
- Hardware control pins for Output Enable
- Optional dual input capability with MUX
- 1.8–3.3 V power supply
- Pb-free, RoHS-6 compliant

Table of Contents

1. Features List	4
2. Ordering Guide	5
3. Functional Description	6
3.1 Functional Block Diagrams	6
3.1.1 Si53352A-D01AM Functional Block Diagram	6
3.1.2 Si53354A-D01AM Functional Block Diagram	6
3.1.3 Si53358A-D01AM Functional Block Diagram	7
3.1.4 Si53350A-D01AM Functional Block Diagram	8
3.1.5 Si53352BDxxxxx-AM Functional Block Diagram	8
3.1.6 Si53354BDxxxxx-AM Functional Block Diagram	9
3.1.7 Si53358BDxxxxx-AM Functional Block Diagram	9
3.1.8 Si53350BDxxxxx-AM Functional Block Diagram	10
3.2 Output Signal Formats	11
3.2.1 Differential Output Terminations	12
3.2.2 LVCMOS Output Terminations	14
3.2.3 LVCMOS Output Signal Swing	15
3.2.4 LVCMOS Output Polarity	15
3.2.5 Termination for HCSL Outputs	15
3.3 Output Enable/Disable	15
3.4 Universal Hardware Pins (Si53352BDxxxxx-AM, Si53354BDxxxxx-AM, Si53358BDxxxxx-AM, and Si53350BDxxxxx-AM)	15
4. Power Supply Filtering Recommendations	17
5. Electrical Specifications	18
6. Pin Descriptions	25
6.1 Si53350A-D01AM and Si53350BD12748-AM Pin Descriptions (48-QFN)	25
6.2 Si53350BDxxxxx-AM Pin Descriptions (48-QFN)	29
6.3 Si53358A-D01AM and Si53352BD12749-AM Pin Descriptions (40-QFN)	33
6.4 Si53358BDxxxxx-AM Pin Descriptions (40-QFN)	36
6.5 Si53354A-D01AM and Si53354BD12750-AM Pin Descriptions (40-QFN)	39
6.6 Si53354BDxxxxx-AM Pin Descriptions (40-QFN)	42
6.7 Si53352A-D01AM and Si53352BD12751-AM Pin Descriptions (32-QFN)	45
6.8 Si53352BDxxxxx-AM Pin Descriptions (32-QFN)	48
7. Package Outline	51
7.1 7x7 mm 48-QFN Package Diagram	51
7.2 6x6 mm 40-QFN Package Diagram	53
7.3 5x5 mm 32-QFN Package Diagram	54
8. PCB Land Pattern	56
8.1 48-QFN Land Pattern	56

8.2 40-QFN Land Pattern.57

8.3 32-QFN Land Pattern.59

9. Top Marking. 61

10. Document Change List 62

1. Features List

- 10, 8, 4, 2-output ordering options
- Loss of signal (LOS) monitors for loss of input clock
- AEC-Q100 qualified
- AEC-Q006 qualified
- Automotive grade 2: -40 to +105 °C
- 10 - 250 MHz frequency range
- Customization option using ClockBuilder Pro
 - Individual output format level programmability
- Excellent additive jitter performance
 - 120 fs RMS, 156.25 MHz
- Individual hardware control pins for Output Enable
- Optional dual input capability with MUX
- 1.8–3.3 V power supply
- Pb-free, RoHS-6 compliant

2. Ordering Guide

Input/Output Format Configuration	Number of Inputs	Number of Outputs	Part Number ¹	Package Type	Temperature
Pin-Selectable	1	2	Si53352A-D01AM	32-pin QFN	-40 °C to +105 °C, Automotive Grade 2
	2	4	Si53354A-D01AM	40-pin QFN	
	2	8	Si53358A-D01AM	40-pin QFN	
	2	10	Si53350A-D01AM	48-pin QFN	
	1	2	Si53358BD12751-AM ²	32-pin QFN	
	2	4	Si53358BD12750-AM ²	40-pin QFN	
	2	8	Si53358BD12749-AM ²	40-pin QFN	
	2	10	Si53350BD12748-AM ²	48-pin QFN	
User-Defined (ClockBuilder Pro)	1	2	Si53352BD-xxxxx-AM ³	32-pin QFN	
	2	4	Si53354BD-xxxxx-AM ³	40-pin QFN	
	2	8	Si53358BD-xxxxx-AM ³	40-pin QFN	
	2	10	Si53350BD-xxxxx-AM ³	48-pin QFN	

Note:

1. For tape and reel, add "R" to the end of the orderable part number.
2. These devices support complementary LVCMOS output format, please see section 3.2 for more details.
3. For user-defined devices, the "xxxxx" suffix is generated by ClockBuilder Pro after a configuration file is created.

3. Functional Description

3.1 Functional Block Diagrams

3.1.1 Si53352A-D01AM Functional Block Diagram

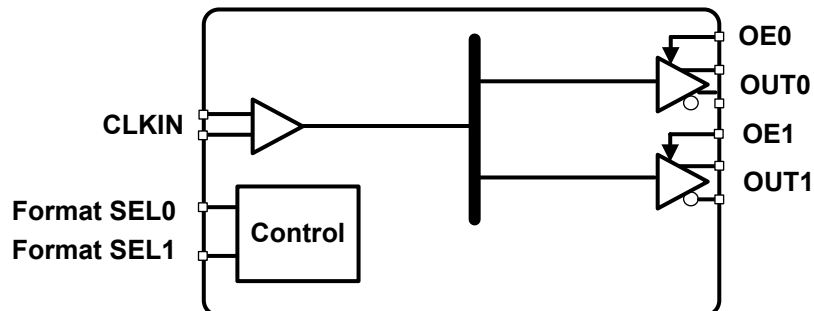

Figure 3.1. Si53352A-D01AM Functional Block Diagram

3.1.2 Si53354A-D01AM Functional Block Diagram

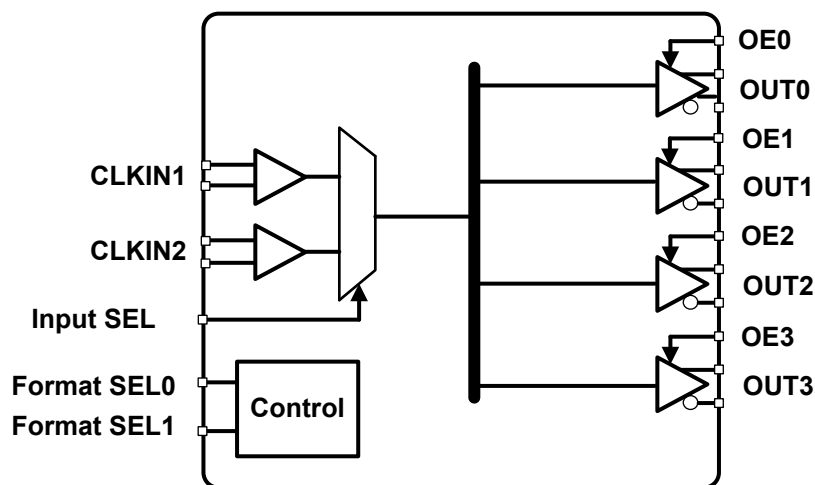

Figure 3.2. Si53354A-D01AM Functional Block Diagram

3.1.3 Si53358A-D01AM Functional Block Diagram

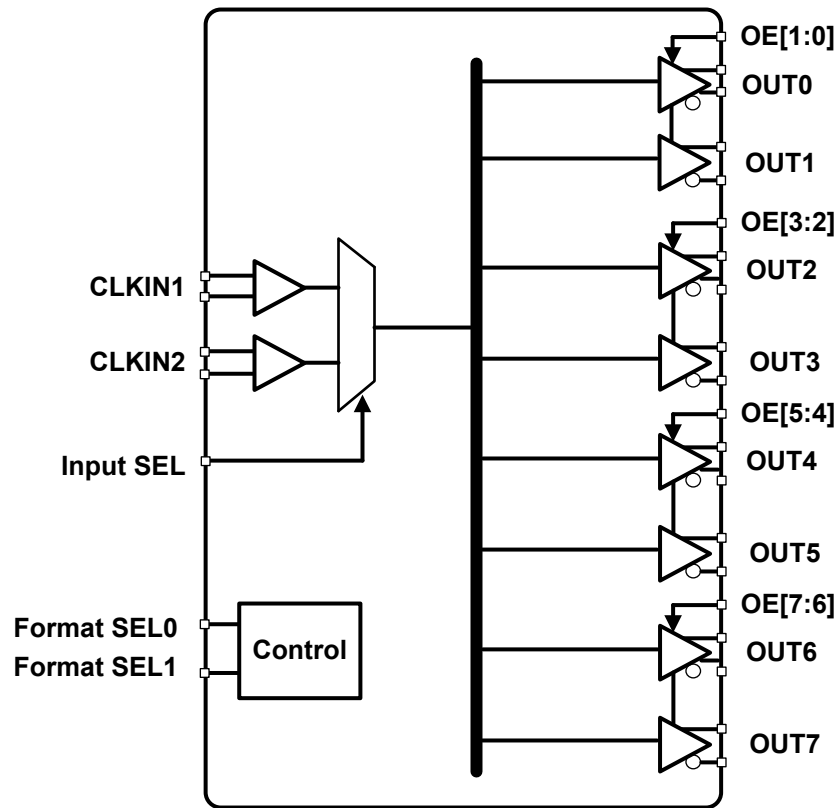

Figure 3.3. Si53358A-D01AM Functional Block Diagram

3.1.4 Si53350A-D01AM Functional Block Diagram

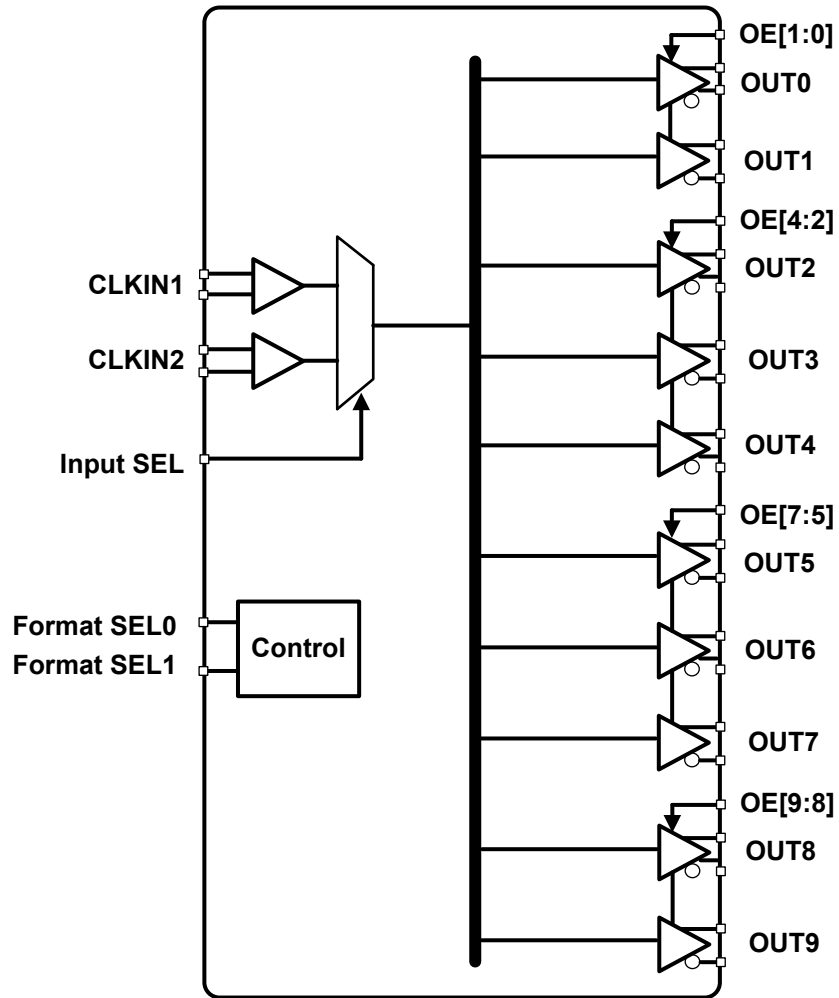

Figure 3.4. Si53350A-D01AM Functional Block Diagram

3.1.5 Si53352BDxxxx-AM Functional Block Diagram

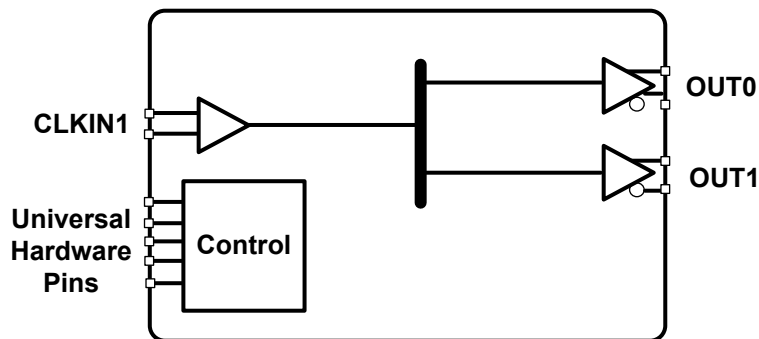

Figure 3.5. Si53352BDxxxx-AM Functional Block Diagram

3.1.6 Si53354BDxxxx-AM Functional Block Diagram

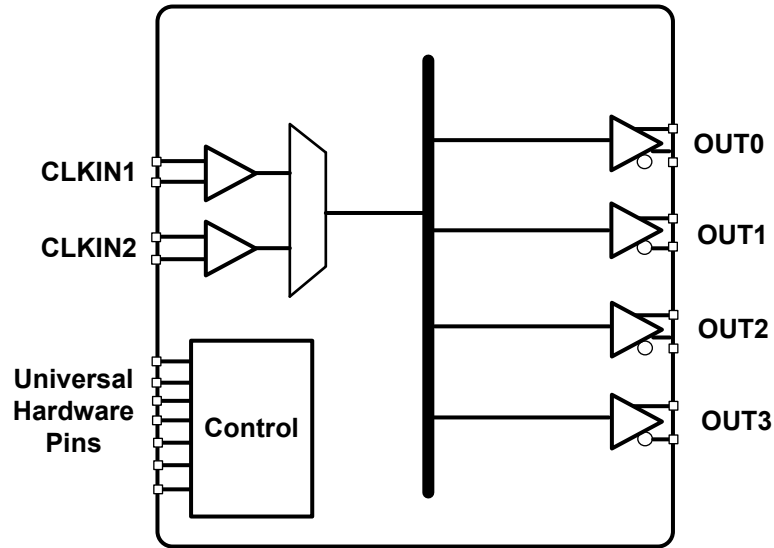

Figure 3.6. Si53354BDxxxx-AM Functional Block Diagram

3.1.7 Si53358BDxxxx-AM Functional Block Diagram

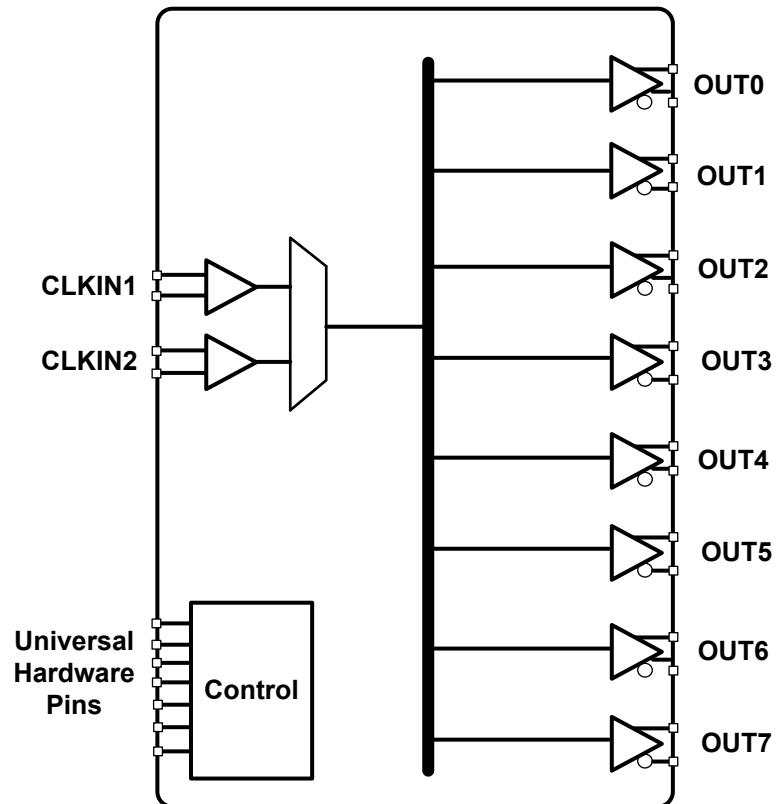

Figure 3.7. Si53358BDxxxx-AM Functional Block Diagram

3.1.8 Si53350BDxxxxx-AM Functional Block Diagram

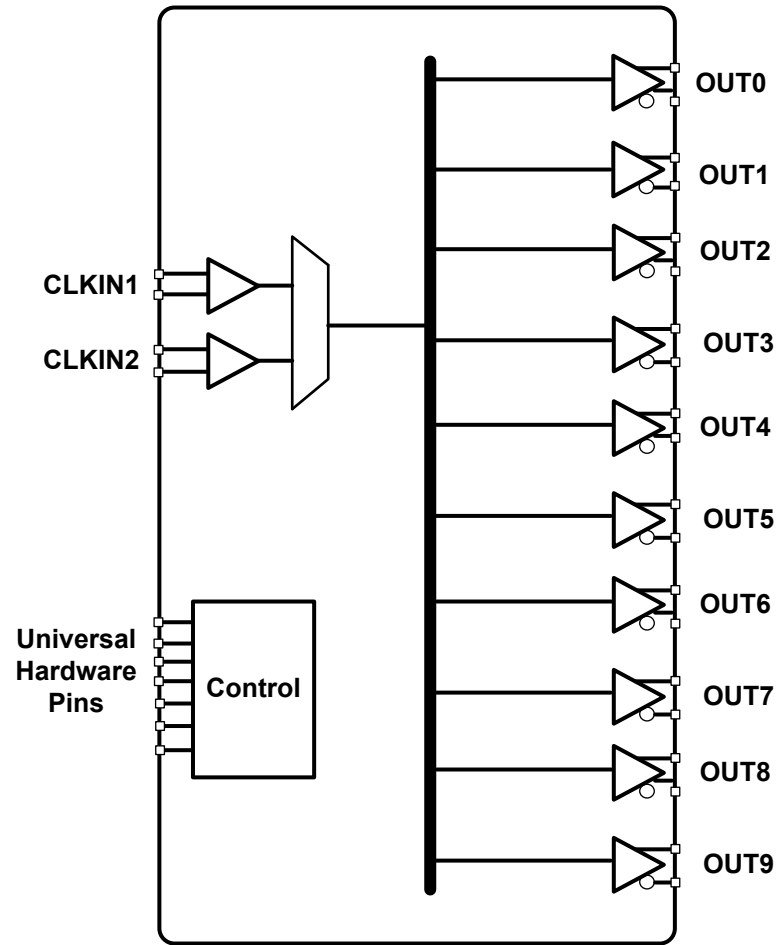

Figure 3.8. Si53350BDxxxxxx-AM Functional Block Diagram

3.2 Output Signal Formats

The differential output swing and common mode voltage are compatible with a wide variety of signal formats including HCSL, LVDS, and LVPECL. In addition to supporting differential signals, the Si5335x devices support LVCMOS in-phase output drivers as well as complementary LVCMOS output drivers. User-defined customization is available using ClockBuilder Pro, each individual output driver can be set to any single-ended or differential output format to exactly match system requirements without using external level translation circuits.

Si53352A-D01AM, Si53354A-D01AM, and Si53358A-D01AM signal formats can be set using the pre-defined hardware input pins as follows:

Format_SEL1	Format_SEL0	Input Format	Output Format	Valid VDDO Voltages
0	0	LVCMOS	LVCMOS (in-phase, dual outputs)	1.8V – 3.3V
0	1	Differential	LVPECL	2.5V or 3.3V
1	0		LVDS	2.5V or 3.3V
1	1		HCSL (100 Ω)	1.8V – 3.3V

Using Si53352A-D01AM, Si53354A-D01AM, and Si53358A-D01AM in Format_SEL[1:0]=00 mode (LVCMOS in-phase, dual outputs) is not recommended for new designs. Silicon Labs has performed extensive system level EMI/EMC testing to CISPR25 Class-4 and Class-5 specifications using both LVCMOS (in-phase dual outputs) and complementary LVCMOS output drivers. Results show that generating single-ended clocks using complementary LVCMOS output drivers have significantly lower impact on system EMI/EMC, therefore Silicon Labs recommends the use of complementary LVCMOS drivers for all single-ended clocks. A complete overview of the testing and recommended design guidelines is summarized in [AN1237](#). The Si5335x automotive buffer products are customizable using [ClockBuilder Pro](#), which provides the option of selecting complementary LVCMOS output drivers during configuration file development. For fixed function versions of Si5335x using complementary LVCMOS output drivers, Silicon Labs has created the following orderable part numbers, which are available and in production:

Orderable Part Number	Number of Outputs	Input Format	Output Format	Valid VDDO Voltages
Si53352BD12751-AM	2	LVCMOS	Complementary LVCMOS	1.8V – 3.3V
Si53354BD12750-AM	4	LVCMOS	Complementary LVCMOS	1.8V – 3.3V
Si53358BD12749-AM	8	LVCMOS	Complementary LVCMOS	1.8V – 3.3V
Si53350BD12748-AM	10	LVCMOS	Complementary LVCMOS	1.8V – 3.3V

Note:

1. Format_SEL1 and Format_SEL0 are unused for these part numbers, connect those pins to ground.

Pinout diagrams and descriptions can be found in the data sheet addendum for the devices noted above by typing in the orderable part number in the “Look Up or Customize an Oscillator or Clock” field at <https://www.silabs.com/timing/lookup-customize>.

3.2.1 Differential Output Terminations

LVDS Driver Termination

For a general LVDS interface, the recommended value for the differential termination impedance (Z_T) is between $90\ \Omega$ and $132\ \Omega$. Select the actual value to match the differential impedance (Z_0) of the transmission line. A typical point-to-point LVDS design uses a $100\ \Omega$ parallel resistor at the receiver and a $100\ \Omega$ differential transmission-line environment. To avoid any transmission-line reflection issues, surface mount the components and place them as close to the receiver as possible. The standard LVDS termination schematic as shown in [Figure 3.9 on page 12](#) can be used with either type of output structure. [Figure 3.10 on page 12](#), which can also be used with both output types, is an optional termination with center tap capacitance to help filter common mode noise. The capacitor value should be approximately 0.01 to $0.1\ \mu\text{F}$. If using a non-standard termination, contact Silicon Labs to confirm if the output structure is current source or voltage source type. In addition, since these outputs are LVDS compatible, the input receiver's amplitude and common-mode input range should be verified for compatibility with the output.

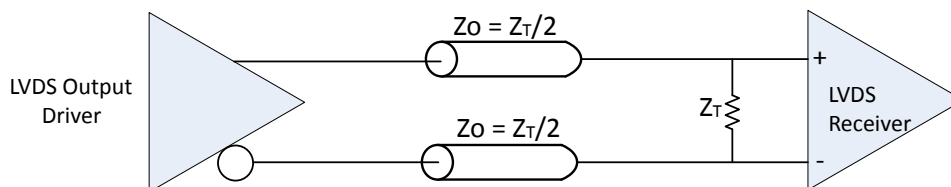

Figure 3.9. Standard LVDS Termination

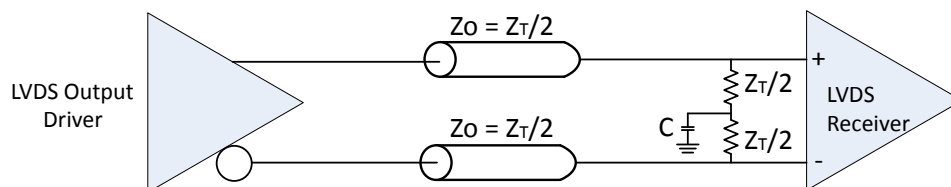

Figure 3.10. Optional LVDS Termination

Termination for 3.3 V LVPECL Outputs

The clock layout topology shown below is a typical termination for LVPECL outputs. The two different layouts mentioned are recommended only as guidelines. The differential outputs generate LVPECL compatible outputs. Therefore, terminating resistors (DC current path to ground) or current sources must be used for functionality. These outputs are designed to drive $50\ \Omega$ transmission lines. Use matched impedance techniques to maximize operating frequency and minimize signal distortion. [Figure 3.11 on page 13](#) and [Figure 3.12 on page 13](#) show two different layouts. Other suitable clock layouts may exist, but it is recommended that the board designers simulate to guarantee compatibility across all printed circuit and clock component process variations.

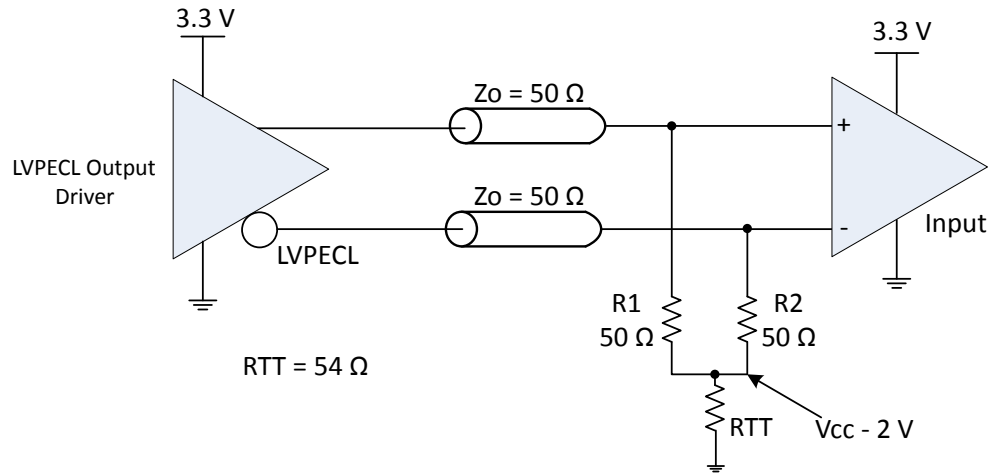

Figure 3.11. 3.3 V LVPECL Output Termination, Option 1

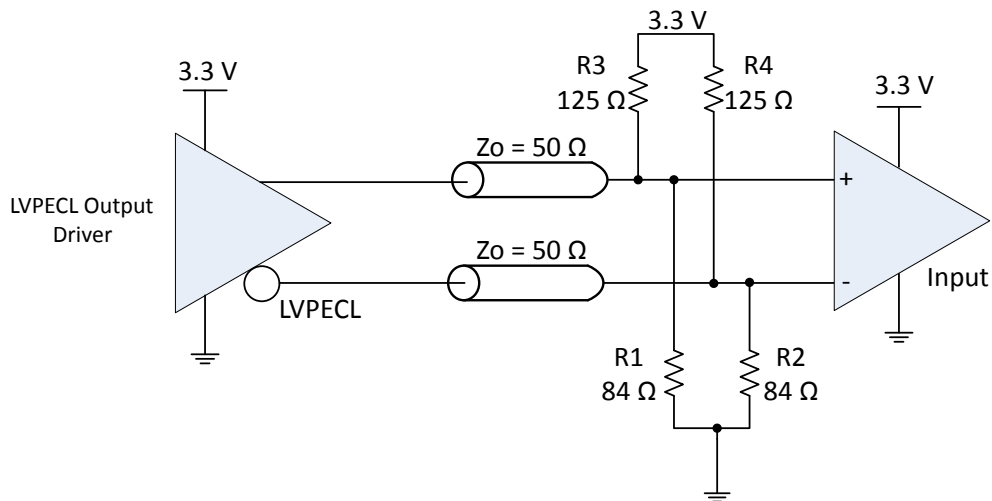

Figure 3.12. 3.3 V LVPECL Output Termination, Option 2

Termination for 2.5 V LVPECL Outputs

Figure 3.13 on page 14 and Figure 3.14 on page 14 show examples of termination for the 2.5 V LVPECL driver option. These terminations are equivalent to terminating 50 Ω to $V_{DDO} - 2\text{ V}$. For $V_{DDO} = 2.5\text{ V}$, the $V_{DDO} - 2\text{ V}$ is very close to ground level. The R3 in Figure 3.14 on page 14 can be optionally eliminated using the termination shown in Figure 3.13 on page 14.

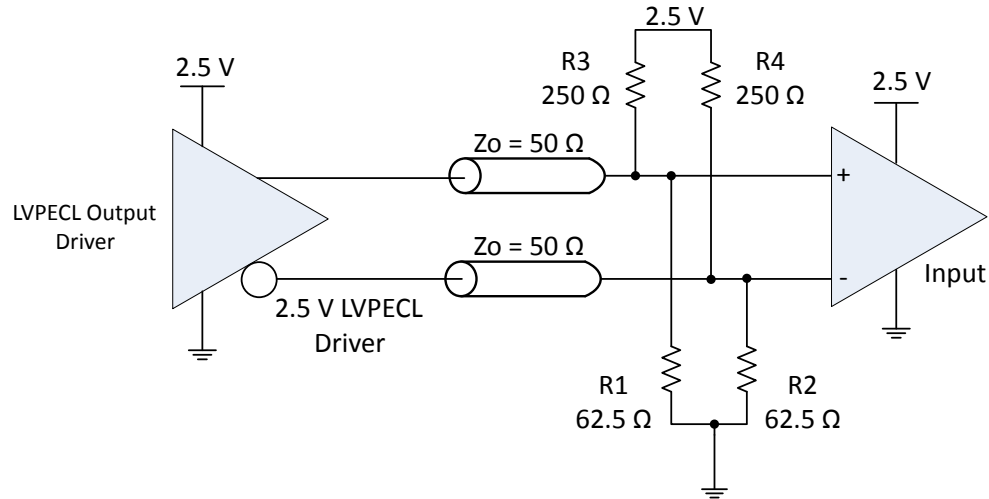

Figure 3.13. 2.5 V LVPECL Termination Example, Option 1

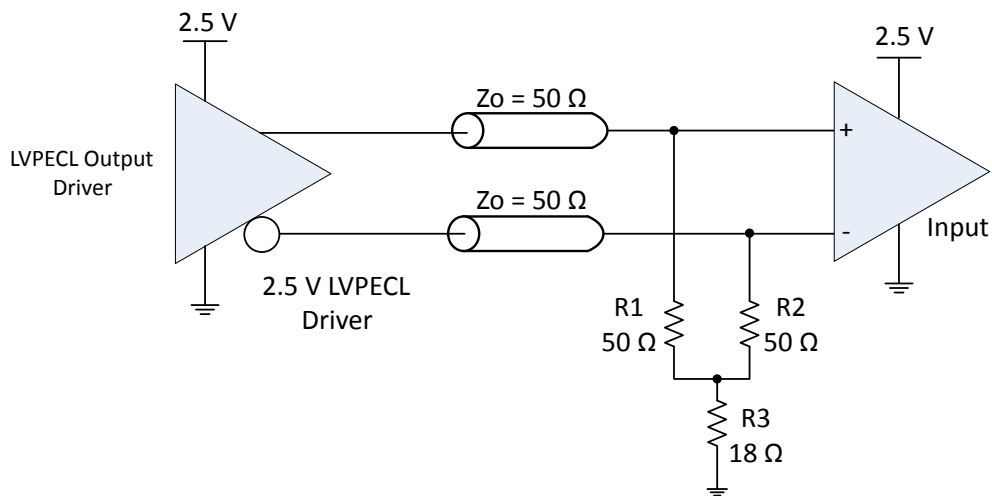

Figure 3.14. 2.5 V LVPECL Termination Example, Option 2

3.2.2 LVCMOS Output Terminations

LVCMOS outputs can be dc-coupled, as shown in the figure below.

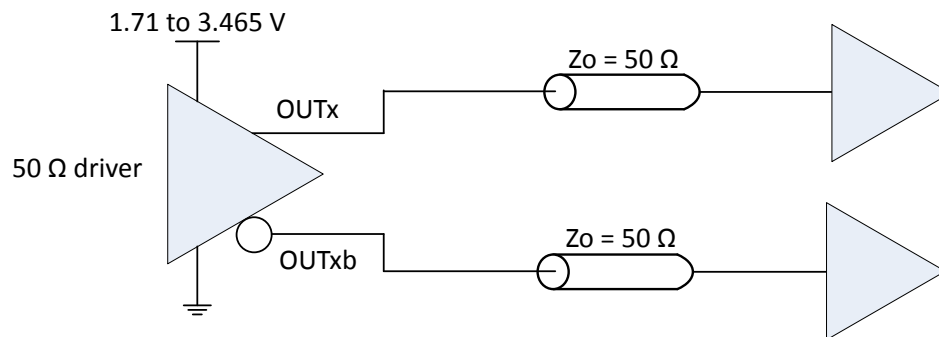

Figure 3.15. LVCMOS Output Termination Example, Option 1

3.2.3 LVCMOS Output Signal Swing

The signal swing (V_{OL}/V_{OH}) of the LVCMOS output drivers is set by the voltage on the VDDO pin for the respective bank.

3.2.4 LVCMOS Output Polarity

When a driver is configured as an LVCMOS output, it generates a clock signal on both pins (OUTx and OUTxb). By default, the clock on the OUTxb pin is generated in phase with the clock on the OUTx pin, unless complementary LVCMOS is explicitly selected.

3.2.5 Termination for HCSL Outputs

The Si5335x HCSL driver features integrated termination resistors to simplify interfacing to an HCSL receiver.

Si53352A-D01AM, Si53354A-D01AM, Si53358A-D01AM, and Si53350A-D01AM have pre-defined feature HCSL drivers set to match 100 Ω impedance and do not require any external termination.

Si53352BDxxxx-AM, Si53354BDxxxx-AM, Si53358BDxxxx-AM, and Si53350ADxxxx-AM have output feature programmable HCSL output drivers that can be set to match either 100 Ω or 85 Ω impedance in ClockBuilder Pro.

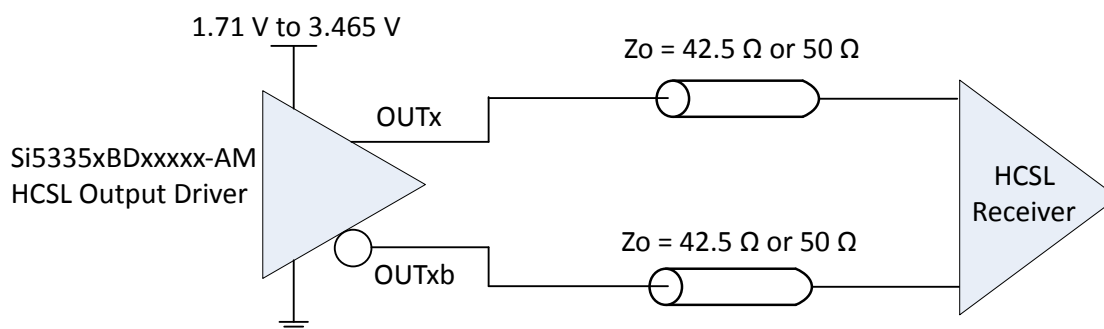

Figure 3.16. HCSL Internal Termination Mode

3.3 Output Enable/Disable

Output enable hardware pins provide a convenient method of disabling or enabling the output drivers. When the output enable pin is held high all designated outputs will be disabled. When held low, the designated outputs will be enabled.

Si53352A-D01AM, Si53354A-D01AM, Si53358A-D01AM, Si53350A-D01AM, Si53350BD12751-AM, Si53350BD12750-AM, Si53350BD12749-AM, and Si53350BD12748-AM have pre-defined output enable pins. Upon de-assertion of an OE pin, the corresponding output will be disabled within 2-6 clock cycles. Asserting an OE pin from disable to enable will take <20 μ s for the output to have a clean clock. Output enabled/disabled for LVCMOS are done in pairs. Each differential buffer True and Compliment output can generate an LVCMOS clock and the OE pin associated with the True and Compliment output buffer will control the respective LVCMOS pair.

Users can opt to define universal hardware pins on Si53352BDxxxx-AM, Si53354BDxxxx-AM, Si53358BDxxxx-AM, and Si53350ADxxxx-AM as output enable for any output, or any combination of outputs. See Section 3.4 for more details.

3.4 Universal Hardware Pins (Si53352BDxxxx-AM, Si53354BDxxxx-AM, Si53358BDxxxx-AM, and Si53350BDxxxx-AM)

Universal hardware input pins are user-configurable control input pins that can have one or more of the functions listed below assigned to them using ClockBuilder Pro.

Universal hardware pins can be utilized for the following functions:

Description	Type	Function
OE	Input	Output enable for one or more outputs.
Input SEL	Input	Selects between input sources, if 2 input clocks are defined.
LOS	Output	Loss of signal monitor

Output Enable

A universal hardware input pin can be defined to control output enable of a differential output, a bank of differential outputs, or as a global output enable pin controlling all outputs. Upon de-assertion of an OE pin, the corresponding output will be disabled within 2-6 clock cycles. Asserting an OE pin from disable to enable will take <20 μ s for the output to have a clean clock.

Input SEL

A universal hardware input pin can be defined to set the input source clock between the input clocks, if two input clock sources are defined. Upon switching the input clock source, the output will not be glitch free. It is intended for the user to set this pin to a known state before the system is powered up or have the receiver address any unintended output signals when switching to a different input source clock.

Loss of Signal (LOS)

LOS is a feature that can be implemented during configuration file development using ClockBuilder Pro on a customized device. The LOS indicator is used to check for the presence of an input reference source (crystal or clock). Users can choose either active high or active low logic when the LOS pin is defined. LOS will assert when the reference source frequency drops below the minimum input frequency (F_{in}) specifications noted in [Table 5.3 Clock Input Specifications on page 19](#).

For Active High:

Poll the LOS pin to check for the presence of the currently selected input clock. In the event that a reference source is not present, the associated LOS pin will assume a logic high (LOS = 1) state. When a reference source is present at the associated input clock pin, the LOS pin will assume a logic low (LOS = 0) state.

For Active Low:

Poll the LOS pin to check for the presence of the currently selected input clock. In the event that a reference source is not present, the associated LOS pin will assume a logic low (LOS = 0) state. When a reference source is present at the associated input clock pin, the LOS pin will assume a logic high (LOS = 1) state.

4. Power Supply Filtering Recommendations

The Si5335x features internal LDOs on each power supply pin, providing excellent power supply noise rejection. As a guideline, each power supply pin should use a parallel combination of a 1 μf and a 0.1 μF bypass capacitor placed as close to the supply pin as possible.

5. Electrical Specifications

Table 5.1. Recommended Operating Conditions
 $(V_{DD} = V_{DDA} = V_{DD_DIG} = 1.8\text{ V to }3.3\text{ V }+5\%/-5\%, V_{DDO} = 1.8\text{ V } \pm 5\%, 2.5\text{ V } \pm 5\%, \text{ or } 3.3\text{ V } \pm 5\%, T_A = -40\text{ to }105\text{ }^\circ\text{C})$

Parameter	Symbol	Test Condition	Min	Typ	Max	Units
Ambient Temperature	T_A		-40	25	105	$^\circ\text{C}$
Junction Temperature	T_{JMAX}		—	—	125	$^\circ\text{C}$
Core Supply Voltage	$V_{DDA}, V_{DD_DIG}, V_{DD}$		1.71	—	3.46	V
Output Driver Supply Voltage	V_{DDO}		1.71	—	3.46	V

Note:

1. All minimum and maximum specifications are guaranteed and apply across the recommended operating conditions. Typical values apply at nominal supply voltages and an operating temperature of 25 $^\circ\text{C}$ unless otherwise noted.

Table 5.2. DC Characteristics
 $(V_{DD} = V_{DDA} = V_{DD_DIG} = 1.8\text{ V to }3.3\text{ V }+5\%/-5\%, V_{DDO} = 1.8\text{ V } \pm 5\%, 2.5\text{ V } \pm 5\%, \text{ or } 3.3\text{ V } \pm 5\%, T_A = -40\text{ to }105\text{ }^\circ\text{C})$

Parameter	Symbol	Test Condition	Min	Typ	Max	Units
Core Supply Current	I_{DD}		—	11	18	mA
Output Buffer Supply Current	I_{DDOx}	LVPECL Output ¹ @ 156.25 MHz	—	33	35	mA
		HCSL Output ¹ @ 100 MHz	—	20	22	mA
		LVDS Output ¹ @ 156.25 MHz	—	11	13	mA
		3.3 V VDDO LVCMOS ² output @ 170 MHz	—	16	19	mA
		2.5 V VDDO LVCMOS ² output @ 170 MHz	—	9	11	mA
		1.8 V VDDO LVCMOS ² output @ 170 MHz	—	7.5	8.5	mA
Total Power Dissipation	P_d	48-pin	—	400	1150	mW
		40-pin	—	260	670	mW
		32-pin	—	80	215	mW

Notes:

- Differential outputs terminated into a 100 Ω load.
- LVCMOS outputs measured into a 5 inch 50 Ω PCB trace with 4 pF load.

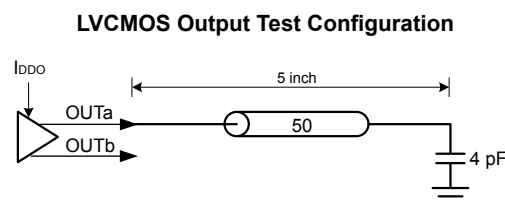
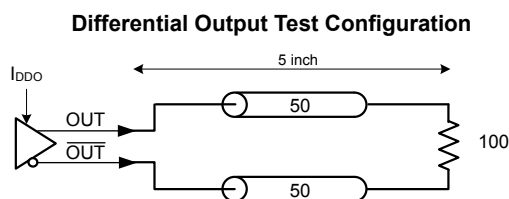

- Detailed power consumption for any configuration can be estimated using [ClockBuilderPro](#) when an evaluation board (EVB) is not available. All EVBs support detailed current measurements for any configuration.

Table 5.3. Clock Input Specifications(V_{DD} = V_{DDA} = V_{DD_DIG} = 1.8 V to 3.3 V +5%/-5%, V_{DDO} = 1.8 V ±5%, 2.5 V ±5%, or 3.3 V ±5%, T_A = -40 to 105 °C)

Parameter	Symbol	Test Condition	Min	Typ	Max	Units
Input Clock (AC-coupled Differential Input Clock on CLKIN_2/CLKIN_2# or CLKIN_3/CLKIN_3#)						
Frequency	F _{IN}	Differential	10	—	250	MHz
Voltage Swing	V _{PP_DIFF} ³	Differential AC-coupled < 250 MHz	0.5	—	1.8	V _{PP_diff}
Slew Rate	SR/SF	20-80%	0.75	—	—	V/ns
Duty Cycle	DC		40	—	60	%
Input Impedance	R _{IN}		10	—	—	kΩ
Input Capacitance	C _{IN}		2	3.5	6	pF
Input Clock (AC-coupled LVCMOS Input Clock on CLKIN_2 or CLKIN_3)						
Frequency	F _{IN}		10	—	170	MHz
Input High Voltage	V _{IH}		0.8 × V _{DD}	—	—	V
Input Low Voltage	V _{IL}		—	—	0.2 × V _{DD}	V
Slew Rate ^{1,2}	SR/SF	20-80%	0.75	—	—	V/ns
Duty Cycle	DC		40	—	60	%
Input Capacitance	C _{IN}		2	3.5	6	pF
Notes:						
1. Imposed for jitter performance.						
2. Rise and fall times can be estimated using the following simplified equation: $tr/tf_{80-20} = ((0.8 - 0.2) * V_{IN_Vpp_se}) / SR$.						
3. V _{PP_DIFF} = 2 × V _{PP_SINGLE-ENDED}						

Table 5.4. Control Pins(V_{DD} = V_{DDA} = V_{DD_DIG} = 1.8 V to 3.3 V +5%/-5%, or 3.3 V ±5%, T_A = -40 to 105 °C)

Parameter	Symbol	Test Condition	Min	Typ	Max	Units
Si5332 Control Input Pins (Universalx)						
Input Voltage	V _{IL}		-0.1	—	0.3 × V _{DD} ¹	V
	V _{IH}		0.7 × V _{DD} ¹	—	1.1 × V _{DD}	V
Input Capacitance	C _{IN}		—	—	4	pF
Pull-up/down Resistance	R _{IN}		—	50	—	kΩ
Note:						
1. V _{DD} indicates all core voltages V _{DD_DIG} , V _{DDA} , and V _{DD_XTAL} which are required to all be using same nominal voltage.						

Table 5.5. Differential Clock Output Specifications(V_{DD} = V_{DDA} = V_{DD_DIG} = 1.8 V to 3.3 V +5%/-5%, V_{DDO} = 1.8 V ±5%, 2.5 V ±5%, or 3.3 V ±5%, T_A = -40 to 105 °C)

Parameter	Symbol	Test Condition		Min	Typ	Max	Units
Output-Output Skew	T _{SK}	Within the same bank		—	—	30	ps
		Across banks		—	—	80	ps
Output Voltage Swing	V _{SEPP}	LVPECL		0.6	0.75	0.85	V _{PP}
		LVDS	1.8/2.5/3.3 V	0.3	0.375	0.45	V _{PP}
		HCSL		0.7	0.8	0.9	V _{PP}
Common Mode Voltage	V _{CM}	LVPECL		—	V _{DDO} -1.4	—	V
		LVDS	2.5/3.3 V	1.125	1.2	1.275	V
		LVDS	1.8 V	0.75	0.8	0.85	V
		HCSL		0.35	0.4	0.45	V
HCSL Edge Rate	Edgr	Notes 2, 4, 6		1	—	4.5	V/ns
HCSL Delta Tr	D _{tr}	Notes 4, 5, 10		—	—	155	ps
HCSL Delta Tf	D _{tf}	Notes 4, 5, 10		—	—	155	ps
HCSL Vcross Abs	V _{xa}	Notes 1, 3, 4, 5		250	—	550	mV
HCSL Delta Vcross	D _{vcrs}	Notes 4, 5, 9		—	—	140	mV
HCSL Vovs	V _{ovs}	Notes 4, 5, 8		—	—	V _{HIGH} +300	mV
HCSL Vuds	V _{uds}	Notes 4, 5, 9		—	—	V _{LOW} -300	mV
HCSL Vrng	V _{rng}	Notes 4, 5		V _{HIGH} -200	—	V _{LOW} +200	mV
Rise and Fall Times (20% to 80%)	t _R /t _F	LVDS (fast mode)	3.3 V or 2.5 V	150	200	350	ps
		LVDS (slow mode)	3.3 V or 2.5 V	350	530	620	ps
			1.8 V	150	225	350	ps
Rise and Fall Times (20% to 80%)	t _R /t _F	LVPECL		150	—	320	ps
		HCSL		—	—	420	ps

Parameter	Symbol	Test Condition	Min	Typ	Max	Units
Notes:						
1. Measured at crossing point where the instantaneous voltage value of the rising edge of CLK equals the falling edge of CLK#.						
2. Measure taken from differential waveform on a component test board. The edge (slew) rate is measured from -150 mV to +150 mV on the differential waveform . Scope is set to average because the scope sample clock is making most of the dynamic wiggles along the clock edge Only valid for Rising clock and Falling Clock#. Signal must be monotonic through the Vol to Voh region for Trise and Tfall.						
3. This measurement refers to the total variation from the lowest crossing point to the highest, regardless of which edge is crossing.						
4. Applies to a 2 pf load with both internal or external 50 Ω or 42.5 Ω Rp.						
5. Measurement taken from Single Ended waveform.						
6. Measurement taken on differential waveform.						
7. Overshoot is defined as the absolute value of the maximum voltage.						
8. Undershoot is defined as the absolute value of the minimum voltage.						
9. ΔVcross is defined as the total variation of all crossing voltages of Rising CLOCK and Falling CLOCK#. This is the maximum allowed variance in Vcross for any particular system.						
10. Measured with oscilloscope, averaging off, using min max statistics. Variation is the delta between min and max.						
11. LVDS swing levels for 50 Ω transmission lines.						
12. Max frequency is 250 MHz.						

Table 5.6. LVCMOS Clock Output Specifications

($V_{DD} = V_{DDA} = V_{DD_DIG} = 1.8\text{ V to }3.3\text{ V } +5\%/-5\%$, $V_{DDO} = 1.8\text{ V } \pm 5\%$, $2.5\text{ V } \pm 5\%$, or $3.3\text{ V } \pm 5\%$, $T_A = -40\text{ to }105\text{ }^\circ\text{C}$)

Parameter	Symbol	Test Condition	Min	Typ	Max	Units
Frequency	fout	1.8-3.3 V CMOS	5	—	170	MHz
		1.5 V CMOS	5	—	133.33	MHz
Rise/Fall Time, 3.3 V (20-80%)	t _R /t _F	50 Ω impedance, 5" trace, CL = 4 pf	—	0.5	0.8	ns
Rise/Fall Time, 2.5 V (20-80%)	t _R /t _F	50 Ω impedance, 5" trace CL = 4 pf	—	0.6	0.95	ns
Rise/Fall Time, 1.8 V (20-80%)	t _R /t _F	50 Ω impedance, 5" trace CL = 4 pf	—	0.75	1.3	ns
Rise/Fall Time, 1.5 V (20-80%)	t _R /t _F	50 Ω impedance, 5" trace CL = 4 pf	—	0.9	1.3	ns
CMOS Output Resistance (Single Strength)		3.3 V	—	46	—	Ω
		2.5 V	—	48	—	Ω
		1.8 V	—	53	—	Ω
		1.5 V	—	58	—	Ω
CMOS Output Voltage	V _{OH}	−4 mA load	V _{DDO} -0.3	—	—	V
	V _{OL}	4 mA load	—	—	0.3	V
Duty Cycle	DC	XO and PLL mode	45	—	55	%

Table 5.7. Performance Characteristics(V_{DD} = V_{DDA} = V_{DD_DIG} = 1.8 V to 3.3 V +5%/-5%, V_{DDO} = 1.8 V ±5%, 2.5 V ±5%, or 3.3 V ±5%, T_A = -40 to 105 °C)

Parameter	Symbol	Test Condition	Min	Typ	Max	Units
Power Ramp	t _{VDD}	0 V to V _{DDmin}	0.1	—	10	ms
Clock Stabilization from Power-up	t _{STABLE}	Time for clock outputs to appear after POR	—	15	25	ms

Table 5.8. Additive Jitter Performance Specifications(V_{DD} = V_{DDA} = V_{DD_DIG} = 1.8 V to 3.3 V +5%/-5%, V_{DDO} = 1.8 V ±5%, 2.5 V ±5%, or 3.3 V ±5%, T_A = -40 to 105 °C)

Parameter	Symbol	Test Condition	Typ	Max	Units
Additive Phase Jitter		156.25 MHz, 12 kHz-20 MHz ¹ , LVDS (slow mode)	130 (LVDS slow)	170	fs RMS
		156.25 MHz, 12 kHz-20 MHz, LVDS (fast mode)	120	150	fs RMS
		156.25 MHz, 12 kHz-20 MHz, LVPECL ¹	110	140	fs RMS
		156.25 MHz, 12 kHz-20 MHz, HCSL ¹	120	150	fs RMS
PCIe Gen3/4 Additive Phase Jitter		100 MHz HCSL input/outputs Includes PLL BW 2–4 MHz, CDR = 10 MHz ^{2, 3, 4, 5}	54	69	fs RMS
PCIe Gen5 Additive Phase Jitter		100 MHz HCSL input/outputs Includes PLL BW 500 kHz - 1.8 MHz, CDR = 20 MHz ^{2, 3, 4, 5}	21	27	fs RMS

Note:

1. Measured with differential input on CLKIN_2, bypassing the PLL to any output.
2. Silicon Labs PCIe Clock Jitter Tool is used to obtain measurements for additive phase jitter. Additive Phase Jitter = sqrt(output jitter² - input jitter²). Input used is 100 MHz from Si5340.
3. Measurements on 100 MHz output use the template file in the PCIe Clock Jitter Tool.
4. For complete PCIe specifications, visit www.pcisig.com.
5. Input clock slew rate of 3.0 V/ns used for jitter measurements.

Table 5.9. Thermal Characteristics

Parameter	Symbol	Test Condition ¹	Value	Units
Si53350 – 48 QFN				
Thermal Resistance, Junction to Ambient	θ_{JA}	Still Air	12 ²	°C/W
		Air Flow 1 m/s	9.7 ²	
		Air Flow 2 m/s	8.7 ²	
Thermal Resistance, Junction to Case	θ_{JC}		2.2 ²	
Thermal Resistance, Junction to Board	θ_{JB}		3.6	
	ψ_{JB}		3.2 ²	
Thermal Resistance, Junction to Top Center	ψ_{JT}		0.4 ²	
Si53258 – 40 QFN				
Thermal Resistance, Junction to Ambient	θ_{JA}	Still Air	23.1 ¹	°C/W
		Air Flow 1 m/s	17.5 ¹	
		Air Flow 2 m/s	16.5 ¹	
Thermal Resistance, Junction to Case	θ_{JC}		13.4 ¹	
Thermal Resistance, Junction to Board	θ_{JB}		8.7 ¹	
	ψ_{JB}		8.4 ¹	
Thermal Resistance, Junction to Top Center	ψ_{JT}		0.3 ¹	
Si53254 — 32 QFN				
Thermal Resistance, Junction to Ambient	θ_{JA}	Still Air	28.4 ¹	°C/W
		Air Flow 1 m/s	24 ¹	
		Air Flow 2 m/s	23 ¹	
Thermal Resistance, Junction to Case	θ_{JC}		15.9 ¹	
Thermal Resistance, Junction to Board	θ_{JB}		11.5 ¹	
	ψ_{JB}		11.2 ¹	
Thermal Resistance, Junction to Top Center	ψ_{JT}		0.4 ¹	
Note:				
1. Based on JEDEC standard 4-layer PCB.				
2. Based on Si53350-D01-AM-QFN48-EVB (PCB dimensions: 9"x9", PCB thickness: 0.062", number of PCB layers: 8).				

Table 5.10. Absolute Maximum Ratings^{1,2,3}

Parameter	Symbol	Test Condition	Value	Units
Storage Temperature Range	T_{STG}		-55 to +150	°C
DC Supply Voltage	V_{DD}		-0.5 to 3.8	V
	V_{DDA}		-0.5 to 3.8	V
	V_{DDO}		-0.5 to 3.8	V
Input Voltage Range	V_I		-0.3 to 1.3	V
Latch-up Tolerance	LU		JESD78 Compliant	
ESD Tolerance	HBM	100 pF, 1.5 kΩ	2.0	kV
	CDM		500	V
Junction Temperature	T_{JCT}		-55 to 125	°C
Soldering Temperature	T_{PEAK}		260	°C
Soldering Temperature Time at T_{PEAK}	T_P		20 to 40	sec

Notes:

1. Permanent device damage may occur if the absolute maximum ratings are exceeded. Functional operation should be restricted to the conditions as specified in the operational sections of this data sheet. Exposure to absolute maximum rating conditions for extended periods may affect device reliability.
2. For more packaging information, go to www.silabs.com/support/quality/pages/RoHSInformation.aspx.
3. The device is compliant with JEDEC J-STD-020.

6. Pin Descriptions

6.1 Si53350A-D01AM and Si53350BD12748-AM Pin Descriptions (48-QFN)

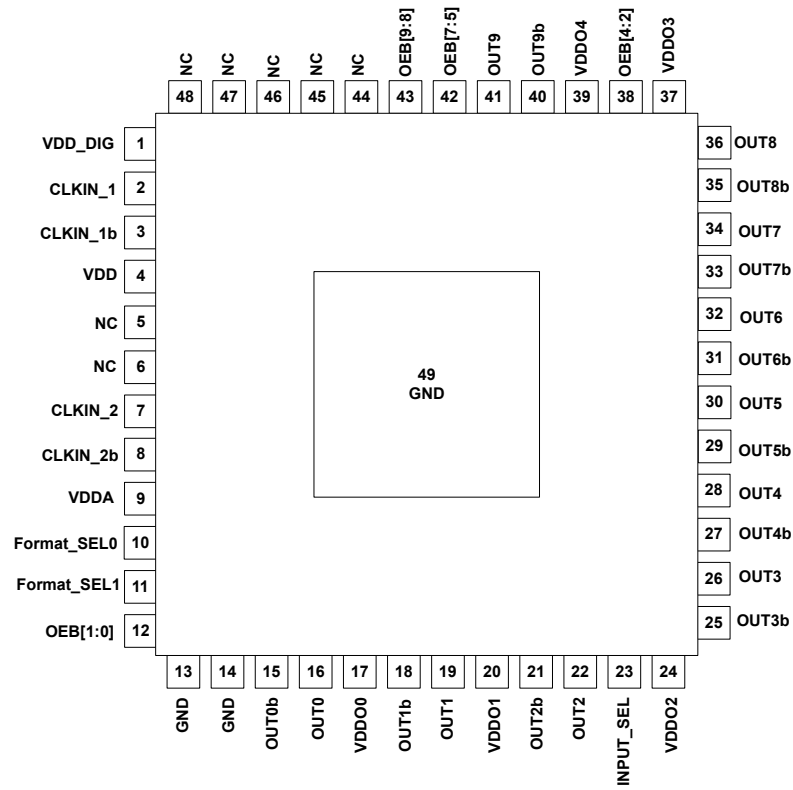

Notes:
 1. Internal 100 kohm pull-down.

Figure 6.1. Si53350A-D01AM and Si53350BD12748-AM (48-QFN)

Table 6.1. Si53350A-D01AM and Si53350BD12748-AM Pin Descriptions (48-QFN)

Pin Number	Pin Name	Pin Type	Function
1	VDD_DIG	P	Voltage supply for digital functions. Connect to 1.8–3.3 V. Part of internal core VDD voltage. Must be connected to same voltage as VDDA and VDD.
2	CLKIN_1	I	Clock input 1. These pins accept both differential and single-ended clock signals. Refer to Section 3.4 Universal Hardware Input Pins - Input_SEL for input termination options. These pins are high-impedance and must be terminated externally. If both the CLKIN_1 and CLKIN_1b inputs are unused and powered down, then both inputs can be left floating. ClockBuilder Pro will power down an input that is set as "Unused".
3	CLKIN_1b	I	
4	VDD	P	Voltage supply. Connect to 1.8–3.3 V. Part of internal core VDD voltage. Must be connected to same voltage as VDDA and VDD_DIG.
5	NC	—	Do not connect these pins to anything.
6	NC	—	
7	CLKIN_2	I	Clock input 2. These pins accept both differential and single-ended clock signals. Refer to Section 3.4 Universal Hardware Input Pins - Input_SEL for input termination options. These pins are high-impedance and must be terminated externally. If both the CLKIN_2 and CLKIN_2b inputs are unused and powered down, then both inputs can be left floating.
8	CLKIN_2b	I	
9	VDDA	P	Core Supply Voltage. Connect to 1.8–3.3 V. Must be connected to same voltage as VDD_DIG and VDD.
10	Format_SEL0	I	Output clock format selection pin. Used in conjunction with Pin 19. Reference Section 3.2 Output Signal Formats . If using Si53350BD12748-AM, do not connect these pins to anything.
11	Format_SEL1	I	
12	OEB[1:0]	I	Output Enable for OUT0 and OUT1 0 = outputs enabled 1 = outputs disabled
13	GND	P	Device GND
14	GND	P	
15	OUT0b	O	Output Clock 0
16	OUT0	O	These output clocks support a programmable signal swing and common mode voltage. Termination recommendations are provided in Section 3.2 Output Signal Formats . Unused outputs should be left unconnected.
17	VDDO0	P	Supply Voltage (1.8–3.3 V, or 1.5 V for CMOS only) for OUT0 Leave VDDOx pins of unused output drivers unconnected. An alternate option is to connect the VDDOx pin to a power supply and disable the output driver to minimize current consumption.
18	OUT1b	O	Output Clock
19	OUT1	O	These output clocks support a programmable signal swing and common mode voltage. Termination recommendations are provided in Section 3.2 Output Signal Formats . Unused outputs should be left unconnected.
20	VDDO1	P	Supply Voltage (1.8–3.3 V, or 1.5 V for CMOS only) for OUT1 and OUT2 Leave VDDOx pins of unused output drivers unconnected. An alternate option is to connect the VDDOx pin to a power supply and disable the output driver to minimize current consumption.

Pin Number	Pin Name	Pin Type	Function
21	OUT2b	O	Output Clock
22	OUT2	O	These output clocks support a programmable signal swing and common mode voltage. Termination recommendations are provided in Section 3.2 Output Signal Formats . Unused outputs should be left unconnected.
23	Input_SEL	I	Input clock selection pin. 0 = CLKIN_1/CLKIN_1b 1 = CLKIN_2/CLKIN_2b
24	VDDO2	P	Supply Voltage (1.8–3.3 V, or 1.5 V for CMOS only) for OUT3, OUT4, and OUT5 Leave VDDOx pins of unused output drivers unconnected. An alternate option is to connect the VDDOx pin to a power supply and disable the output driver to minimize current consumption.
25	OUT3b	O	Output Clock
26	OUT3	O	These output clocks support a programmable signal swing and common mode voltage. Termination recommendations are provided in Section 3.2 Output Signal Formats . Unused outputs should be left unconnected.
27	OUT4b	O	Output Clock
28	OUT4	O	Desired output signal format is defined by IN/OUT_SEL0 and IN/OUT_SEL1. Termination recommendations are provided in Section 3.2 Output Signal Formats . Unused outputs should be left unconnected
29	OUT5b	O	Output Clock
30	OUT5	O	These output clocks support a programmable signal swing and common mode voltage. Termination recommendations are provided in Section 3.2 Output Signal Formats . Unused outputs should be left unconnected.
31	OUT6b	O	Output Clock
32	OUT6	O	These output clocks support a programmable signal swing and common mode voltage. Termination recommendations are provided in Section 3.2 Output Signal Formats . Unused outputs should be left unconnected.
33	OUT7b	O	Output Clock
34	OUT7	O	These output clocks support a programmable signal swing and common mode voltage. Termination recommendations are provided in Section 3.2 Output Signal Formats . Unused outputs should be left unconnected.
35	OUT8b	O	Output Clock
36	OUT8	O	These output clocks support a programmable signal swing and common mode voltage. Termination recommendations are provided in Section 3.2 Output Signal Formats . Unused outputs should be left unconnected.
37	VDDO3	P	Supply Voltage (1.8–3.3 V, or 1.5 V for CMOS only) for OUT6, OUT7, and OUT8 Leave VDDOx pins of unused output drivers unconnected. An alternate option is to connect the VDDOx pin to a power supply and disable the output driver to minimize current consumption.
38	OEB[4:2]	I	Output Enable for OUT2, OUT3, and OUT4 0 = outputs enabled 1 = outputs disabled

Pin Number	Pin Name	Pin Type	Function
39	VDDO4	P	Supply Voltage (1.8–3.3 V, or 1.5 V for CMOS only) for OUT9 Leave VDDOx pins of unused output drivers unconnected. An alternate option is to connect the VDDOx pin to a power supply and disable the output driver to minimize current consumption.
40	OUT9b	O	Output Clock
41	OUT9	O	These output clocks support a programmable signal swing and common mode voltage. Termination recommendations are provided in Section 3.2 Output Signal Formats . Unused outputs should be left unconnected.
42	OEB[7:5]	I	Output enable for OUT5, OUT6, and OUT7. 0 = outputs enabled 1 = outputs disabled
43	OEB[9:8]	I	Output enable for OUT8 and OUT9. 0 = outputs enabled 1 = outputs disabled
44	NC	–	Do not connect these pins to anything.
45	NC	–	
46	NC	–	
47	NC	–	
48	NC	–	
49	Ground	GND	Ground Pad This pad provides electrical and thermal connection to ground and must be connected for proper operation.

6.2 Si53350BDxxxxx-AM Pin Descriptions (48-QFN)

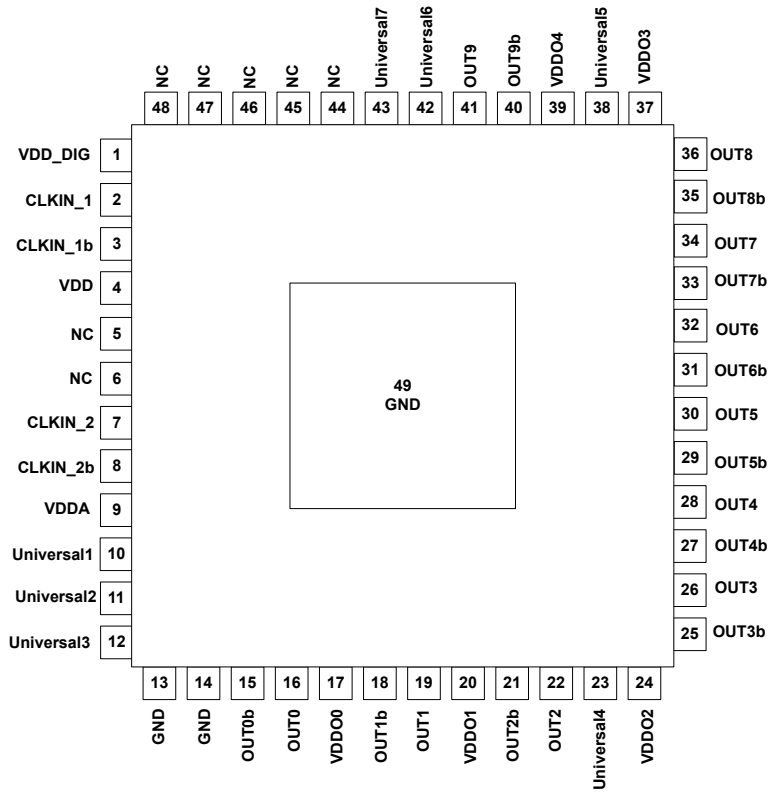

Notes:
 1. Internal 100 kohm pull-down.

Figure 6.2. Si53350BDxxxxx-AM 48-QFN

Table 6.2. Si53350BDxxxx-AM Pin Descriptions (48-QFN)

Pin Number	Pin Name	Pin Type	Function
1	VDD_DIG	P	Voltage supply for digital functions. Connect to 1.8–3.3 V. Part of internal core VDD voltage. Must be connected to same voltage as VDDA and VDD.
2	CLKIN_1	I	Clock input 1. These pins accept both differential and single-ended clock signals. Refer to Section 3.4 Universal Hardware Input Pins - Input_SEL for input termination options. These pins are high-impedance and must be terminated externally. If both the CLKIN_1 and CLKIN_1b inputs are unused and powered down, then both inputs can be left floating. ClockBuilder Pro will power down an input that is set as "Unused".
3	CLKIN_1b	I	
4	VDD	P	Voltage supply. Connect to 1.8–3.3 V. Part of internal core VDD voltage. Must be connected to same voltage as VDDA and VDD_DIG.
5	NC	—	Do not connect these pins to anything.
6	NC	—	
7	CLKIN_2	I	Clock input 2. These pins accept both differential and single-ended clock signals. Refer to Section 3.4 Universal Hardware Input Pins - Input_SEL for input termination options. These pins are high-impedance and must be terminated externally. If both the CLKIN_2 and CLKIN_2b inputs are unused and powered down, then both inputs can be left floating.
8	CLKIN_2b	I	
9	VDDA	P	Core Supply Voltage. Connect to 1.8–3.3 V. Must be connected to same voltage as VDD_DIG.
10	Universal1	I	Universal HW Input pin. This hardware input pin is user definable through ClockBuilder Pro. Refer to Section 3.4 Universal Hardware Input Pins for a list of definitions that hardware input pins can be used for.
11	Universal2	I	Universal HW Input pin. This hardware input pin is user definable through ClockBuilder Pro. Refer to Section 3.4 Universal Hardware Input Pins for a list of definitions that hardware input pins can be used for.
12	Universal3	I	Universal HW Input pin. This hardware input pin is user definable through ClockBuilder Pro. Refer to Section 3.4 Universal Hardware Input Pins for a list of definitions that hardware input pins can be used for.
13	GND	P	Connect these pins to Ground.
14	GND	P	
15	OUT0b	O	Output Clock
16	OUT0	O	These output clocks support a programmable signal swing and common mode voltage. Termination recommendations are provided in Section 3.2 Output Signal Formats . Unused outputs should be left unconnected.
17	VDDO0	P	Supply Voltage (1.8–3.3 V, or 1.5 V for CMOS only) for OUT0 Leave VDDOx pins of unused output drivers unconnected. An alternate option is to connect the VDDOx pin to a power supply and disable the output driver to minimize current consumption.
18	OUT1b	O	Output Clock
19	OUT1	O	These output clocks support a programmable signal swing and common mode voltage. Termination recommendations are provided in Section 3.2 Output Signal Formats . Unused outputs should be left unconnected.

Pin Number	Pin Name	Pin Type	Function
20	VDDO1	P	Supply Voltage (1.8–3.3 V, or 1.5 V for CMOS only) for OUT1 and OUT2 Leave VDDOx pins of unused output drivers unconnected. An alternate option is to connect the VDDOx pin to a power supply and disable the output driver to minimize current consumption.
21	OUT2b	O	Output Clock
22	OUT2	O	These output clocks support a programmable signal swing and common mode voltage. Termination recommendations are provided in Section 3.2 Output Signal Formats . Unused outputs should be left unconnected
23	Universal4	I	Universal HW Input pin. This hardware input pin is user definable through ClockBuilder Pro. Refer to Section 3.4 Universal Hardware Input Pins for a list of definitions that hardware input pins can be used for.
24	VDDO2	P	Supply Voltage (1.8–3.3 V, or 1.5 V for CMOS only) for OUT3, OUT4, and OUT5 Leave VDDOx pins of unused output drivers unconnected. An alternate option is to connect the VDDOx pin to a power supply and disable the output driver to minimize current consumption.
25	OUT3b	O	Output Clock
26	OUT3	O	These output clocks support a programmable signal swing and common mode voltage. Termination recommendations are provided in Section 3.2 Output Signal Formats . Unused outputs should be left unconnected.
27	OUT4b	O	Output Clock
28	OUT4	O	These output clocks support a programmable signal swing and common mode voltage. Termination recommendations are provided in Section 3.2 Output Signal Formats . Unused outputs should be left unconnected.
29	OUT5b	O	Output Clock
30	OUT5	O	These output clocks support a programmable signal swing and common mode voltage. Termination recommendations are provided in Section 3.2 Output Signal Formats . Unused outputs should be left unconnected.
31	OUT6b	O	Output Clock
32	OUT6	O	These output clocks support a programmable signal swing and common mode voltage. Termination recommendations are provided in Section 3.2 Output Signal Formats . Unused outputs should be left unconnected.
33	OUT7b	O	Output Clock
34	OUT7	O	These output clocks support a programmable signal swing and common mode voltage. Termination recommendations are provided in Section 3.2 Output Signal Formats . Unused outputs should be left unconnected.
35	OUT8b	O	Output Clock
36	OUT8	O	These output clocks support a programmable signal swing and common mode voltage. Termination recommendations are provided in Section 3.2 Output Signal Formats . Unused outputs should be left unconnected.
37	VDDO3	P	Supply Voltage (1.8–3.3 V, or 1.5 V for CMOS only) for OUT6, OUT7, and OUT8 Leave VDDOx pins of unused output drivers unconnected. An alternate option is to connect the VDDOx pin to a power supply and disable the output driver to minimize current consumption.
38	Universal5	I	Universal HW Input pin. This hardware input pin is user definable through ClockBuilder Pro. Refer to Section 3.4 Universal Hardware Input Pins for a list of definitions that hardware input pins can be used for.

Pin Number	Pin Name	Pin Type	Function
39	VDDO4	P	Supply Voltage (1.8–3.3 V, or 1.5 V for CMOS only) for OUT9 Leave VDDOx pins of unused output drivers unconnected. An alternate option is to connect the VDDOx pin to a power supply and disable the output driver to minimize current consumption.
40	OUT9b	O	Output Clock
41	OUT9	O	These output clocks support a programmable signal swing and common mode voltage. Termination recommendations are provided in Section 3.2 Output Signal Formats . Unused outputs should be left unconnected.
42	Universal6	I	Universal HW Input pin. This hardware input pin is user definable through ClockBuilder Pro. Refer to Section 3.4 Universal Hardware Input Pins for a list of definitions that hardware input pins can be used for.
43	Universal7	I	Universal HW Input pin. This hardware input pin is user definable through ClockBuilder Pro. Refer to Section 3.4 Universal Hardware Input Pins for a list of definitions that hardware input pins can be used for.
44	NC	–	Do not connect these pins to anything.
45	NC	–	
46	NC	–	
47	NC	–	
48	NC	–	
49	Ground	GND	Ground Pad This pad provides electrical and thermal connection to ground and must be connected for proper operation.

6.3 Si53358A-D01AM and Si53352BD12749-AM Pin Descriptions (40-QFN)

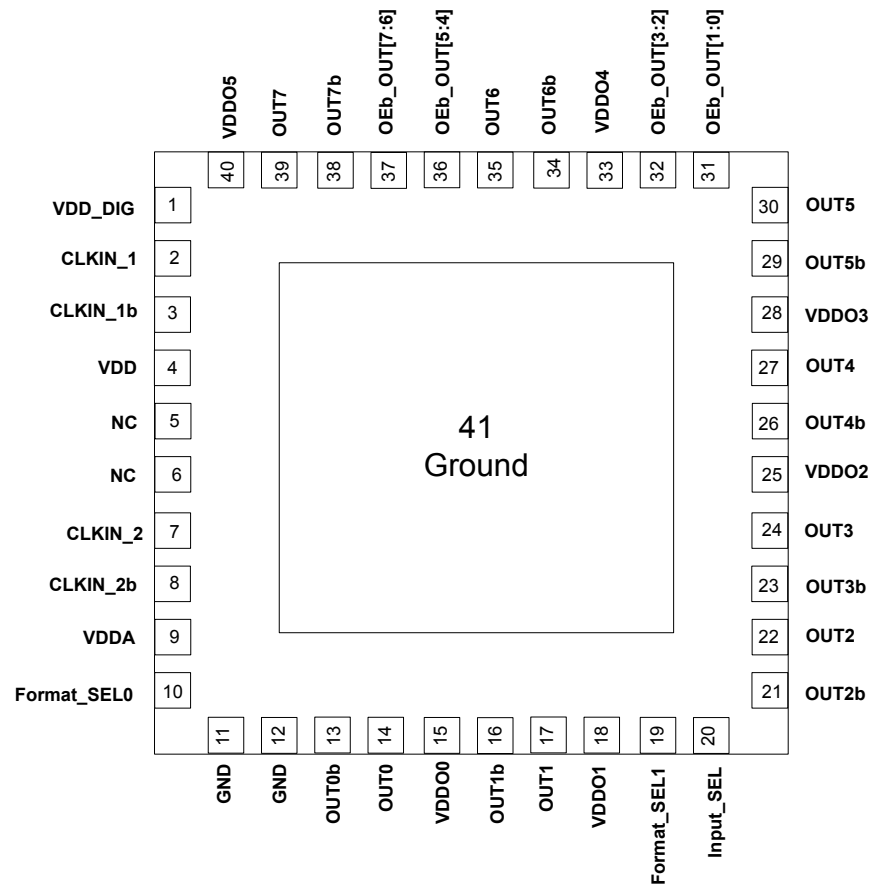

Figure 6.3. Si53358A-D01AM and Si53352BD12749-AM (40-QFN)

Table 6.3. Si53358A-D01AM and Si53352BD12749-AM Pin Descriptions (40-QFN)

Pin Number	Pin Name	Pin Type	Function
1	VDD_DIG	P	Voltage supply for digital functions. Connect to 1.8–3.3 V. Part of internal core VDD voltage. Must be connected to same voltage as VDDA and VDD.
2	CLKIN_1	I	Clock input 1. These pins accept both differential and single-ended clock signals. Refer to Section 3.4 Universal Hardware Input Pins - Input_SEL for input termination options. These pins are high-impedance and must be terminated externally. If both the CLKIN_1 and CLKIN_1b inputs are unused and powered down, then both inputs can be left floating. ClockBuilder Pro will power down an input that is set as "Unused".
3	CLKIN_1b	I	
4	VDD	P	Voltage supply. Connect to 1.8–3.3 V. Part of internal core VDD voltage. Must be connected to same voltage as VDDA and VDD_DIG.
5	NC	—	Do not connect these pins to anything.
6	NC	—	
7	CLKIN_2	I	Clock input 2. These pins accept both differential and single-ended clock signals. Refer to Section 3.4 Universal Hardware Input Pins - Input_SEL for input termination options. These pins are high-impedance and must be terminated externally. If both the CLKIN_2 and CLKIN_2b inputs are unused and powered down, then both inputs can be left floating.
8	CLKIN_2b	I	
9	VDDA	P	Core Supply Voltage. Connect to 1.8–3.3 V. Must be connected to same voltage as VDD_DIG and VDD.
10	Format_SEL0	I	Output clock format selection pin. Used in conjunction with Pin 19. Reference Section 3.2 Output Signal Formats . If using Si53350BD12749-AM, do not connect this pin to anything.
11	GND	P	Connect these pins to ground.
12	GND	P	
13	OUT0b	O	Output Clock
14	OUT0	O	These output clocks support a programmable signal swing and common mode voltage. Termination recommendations are provided in Section 3.2 Output Signal Formats . Unused outputs should be left unconnected
15	VDDO0	P	Supply Voltage (1.8–3.3 V) for OUT0 Leave VDDOx pins of unused output drivers unconnected. An alternate option is to connect the VDDOx pin to a power supply and disable the output driver to minimize current consumption.
16	OUT1b	O	Output Clock
17	OUT1	O	These output clocks support a programmable signal swing and common mode voltage. Termination recommendations are provided in Section 3.2 Output Signal Formats . Unused outputs should be left unconnected
18	VDDO1	P	Supply Voltage (1.8–3.3 V) for OUT1 Leave VDDOx pins of unused output drivers unconnected. An alternate option is to connect the VDDOx pin to a power supply and disable the output driver to minimize current consumption.
19	Format_SEL1	I	Output clock format selection pin. Used in conjunction with Pin 10. Reference Section 3.2 Output Signal Formats . If using Si53350BD12749-AM, do not connect this pin to anything.

Pin Number	Pin Name	Pin Type	Function
20	Input_SEL	I	Input clock selection pin. 0 = CLKIN_1/CLKIN_1b 1 = CLKIN_2/CLKIN_2b
21	OUT2b	O	Output Clock
22	OUT2	O	These output clocks support a programmable signal swing and common mode voltage. Termination recommendations are provided in Section 3.2 Output Signal Formats . Unused outputs should be left unconnected
23	OUT3b	O	Output Clock
24	OUT3	O	These output clocks support a programmable signal swing and common mode voltage. Termination recommendations are provided in Section 3.2 Output Signal Formats . Unused outputs should be left unconnected
25	VDDO2	P	Supply Voltage (1.8–3.3 V) for OUT2 and OUT3 Leave VDDOx pins of unused output drivers unconnected. An alternate option is to connect the VDDOx pin to a power supply and disable the output driver to minimize current consumption.
26	OUT4b	O	Output Clock
27	OUT4	O	These output clocks support a programmable signal swing and common mode voltage. Termination recommendations are provided in Section 3.2 Output Signal Formats . Unused outputs should be left unconnected
28	VDDO3	P	Supply Voltage (1.8–3.3 V) for OUT4 and OUT5 Leave VDDOx pins of unused output drivers unconnected. An alternate option is to connect the VDDOx pin to a power supply and disable the output driver to minimize current consumption.
29	OUT5b	O	Output Clock
30	OUT5	O	These output clocks support a programmable signal swing and common mode voltage. Termination recommendations are provided in Section 3.2 Output Signal Formats . Unused outputs should be left unconnected
31	OEB_OUT[1:0]	I	Output Enable for OUT0 and OUT1 0 = outputs enabled 1 = outputs disabled
32	OEB_OUT[3:2]	I	Output Enable for OUT2 and OUT3 0 = outputs enabled 1 = outputs disabled
33	VDDO4	P	Supply Voltage (1.8–3.3 V) for OUT6 Leave VDDOx pins of unused output drivers unconnected. An alternate option is to connect the VDDOx pin to a power supply and disable the output driver to minimize current consumption.
34	OUT6b	O	Output Clock
35	OUT6	O	These output clocks support a programmable signal swing and common mode voltage. Termination recommendations are provided in Section 3.2 Output Signal Formats . Unused outputs should be left unconnected

Pin Number	Pin Name	Pin Type	Function
36	OEb_OUT[5:4]	I	Output Enable for OUT4 and OUT5 0 = outputs enabled 1 = outputs disabled
37	OEb_OUT[7:6]	I	Output Enable for OUT6 and OUT7 0 = outputs enabled 1 = outputs disabled
38	OUT7b	O	Output Clock These output clocks support a programmable signal swing and common mode voltage. Termination recommendations are provided in Section 3.2 Output Signal Formats . Unused outputs should be left unconnected
39	OUT7	O	
40	VDDO5	P	Supply Voltage (1.8–3.3 V) for OUT7 Leave VDDOx pins of unused output drivers unconnected. An alternate option is to connect the VDDOx pin to a power supply and disable the output driver to minimize current consumption.
41	Ground	GND	Ground Pad This pad provides electrical and thermal connection to ground and must be connected for proper operation.

6.4 Si53358BDxxxx-AM Pin Descriptions (40-QFN)

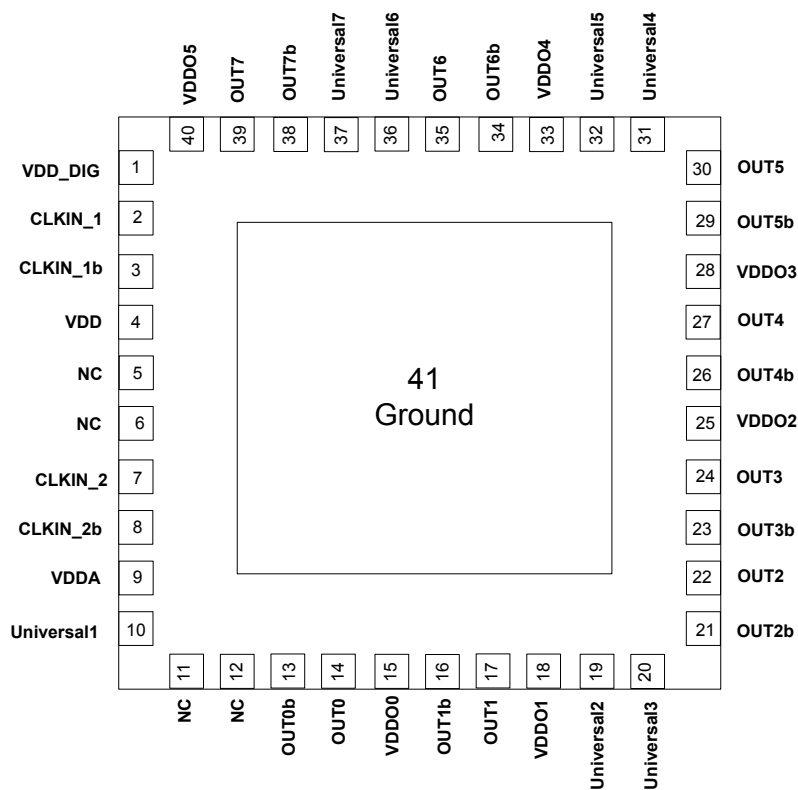

Figure 6.4. Si53358Bxxxx-AM 40-QFN

Table 6.4. Si53358BDxxxx-AM Pin Descriptions (40-QFN)

Pin Number	Pin Name	Pin Type	Function
1	VDD_DIG	P	Voltage supply for digital functions. Connect to 1.8–3.3 V. Part of internal core VDD voltage. Must be connected to same voltage as VDDA and VDD.
2	CLKIN_1	I	Clock input 1. These pins accept both differential and single-ended clock signals. Refer to Section 3.4 Universal Hardware Input Pins - Input_SEL for input termination options. These pins are high-impedance and must be terminated externally. If both the CLKIN_1 and CLKIN_1b inputs are unused and powered down, then both inputs can be left floating. ClockBuilder Pro will power down an input that is set as "Unused".
3	CLKIN_1b	I	
4	VDD	P	Voltage supply. Connect to 1.8–3.3 V. Part of internal core VDD voltage. Must be connected to same voltage as VDDA and VDD_DIG.
5	NC	—	Do not connect these pins to anything.
6	NC	—	
7	CLKIN_2	I	Clock input 2. These pins accept both differential and single-ended clock signals. Refer to Section 3.4 Universal Hardware Input Pins - Input_SEL for input termination options. These pins are high-impedance and must be terminated externally. If both the CLKIN_2 and CLKIN_2b inputs are unused and powered down, then both inputs can be left floating. ClockBuilder Pro will power down an input that is set as "Unused".
8	CLKIN_2b	I	
9	VDDA	P	Core Supply Voltage. Connect to 1.8–3.3 V. Must be connected to same voltage as VDD_DIG.
10	Universal1	I	Universal HW pin. This hardware pin is user definable through ClockBuilder Pro. Refer to Section 3.4 Universal Hardware Input Pins for a list of definitions that hardware pins can be used for.
11	GND	P	Connect these pins to ground.
12	GND	P	
13	OUT0b	O	Output Clock
14	OUT0	O	These output clocks support a programmable signal swing and common mode voltage. Termination recommendations are provided in Section 3.2 Output Signal Formats . Unused outputs should be left unconnected.
15	VDDO0	P	Supply Voltage (1.8–3.3 V) for OUT0 Leave VDDOx pins of unused output drivers unconnected. An alternate option is to connect the VDDOx pin to a power supply and disable the output driver to minimize current consumption.
16	OUT1b	O	Output Clock
17	OUT1	O	These output clocks support a programmable signal swing and common mode voltage. Termination recommendations are provided in Section 3.2 Output Signal Formats . Unused outputs should be left unconnected.
18	VDDO1	P	Supply Voltage (1.8–3.3 V) for OUT1 Leave VDDOx pins of unused output drivers unconnected. An alternate option is to connect the VDDOx pin to a power supply and disable the output driver to minimize current consumption.
19	Universal2	I	Universal HW pin. This hardware pin is user definable through ClockBuilder Pro. Refer to Section 3.4 Universal Hardware Input Pins for a list of definitions that hardware pins can be used for.

Pin Number	Pin Name	Pin Type	Function
20	Universal3	I	Universal HW pin. This hardware pin is user definable through ClockBuilder Pro. Refer to Section 3.4 Universal Hardware Input Pins for a list of definitions that hardware pins can be used for.
21	OUT2b	O	Output Clock These output clocks support a programmable signal swing and common mode voltage. Termination recommendations are provided in Section 3.2 Output Signal Formats . Unused outputs should be left unconnected.
22	OUT2	O	
23	OUT3b	O	Output Clock These output clocks support a programmable signal swing and common mode voltage. Termination recommendations are provided in Section 3.2 Output Signal Formats . Unused outputs should be left unconnected.
24	OUT3	O	
25	VDDO2	P	Supply Voltage (1.8–3.3 V) for OUT2 and OUT3 Leave VDDOx pins of unused output drivers unconnected. An alternate option is to connect the VDDOx pin to a power supply and disable the output driver to minimize current consumption.
26	OUT4b	O	Output Clock These output clocks support a programmable signal swing and common mode voltage. Termination recommendations are provided in Section 3.2 Output Signal Formats . Unused outputs should be left unconnected.
27	OUT4	O	
28	VDDO3	P	Supply Voltage (1.8–3.3 V) for OUT4 and OUT5 Leave VDDOx pins of unused output drivers unconnected. An alternate option is to connect the VDDOx pin to a power supply and disable the output driver to minimize current consumption.
29	OUT5b	O	Output Clock These output clocks support a programmable signal swing and common mode voltage. Termination recommendations are provided in Section 3.2 Output Signal Formats . Unused outputs should be left unconnected.
30	OUT5	O	
31	Universal4	I	Universal HW pin. This hardware pin is user definable through ClockBuilder Pro. Refer to Section 3.4 Universal Hardware Input Pins for a list of definitions that hardware pins can be used for.
32	Universal5	I	Universal HW pin. This hardware pin is user definable through ClockBuilder Pro. Refer to Section 3.4 Universal Hardware Input Pins for a list of definitions that hardware pins can be used for.
33	VDDO4	P	Supply Voltage (1.8–3.3 V) for OUT6 Leave VDDOx pins of unused output drivers unconnected. An alternate option is to connect the VDDOx pin to a power supply and disable the output driver to minimize current consumption.
34	OUT6b	O	Output Clock These output clocks support a programmable signal swing and common mode voltage. Termination recommendations are provided in Section 3.2 Output Signal Formats . Unused outputs should be left unconnected.
35	OUT6	O	
36	Universal6	I	Universal HW pin. This hardware pin is user definable through ClockBuilder Pro. Refer to Section 3.4 Universal Hardware Input Pins for a list of definitions that hardware pins can be used for.
37	Universal7	I	Universal HW pin. This hardware pin is user definable through ClockBuilder Pro. Refer to Section 3.4 Universal Hardware Input Pins for a list of definitions that hardware pins can be used for.

Pin Number	Pin Name	Pin Type	Function
38	OUT7b	O	Output Clock These output clocks support a programmable signal swing and common mode voltage. Termination recommendations are provided in Section 3.2 Output Signal Formats . Unused outputs should be left unconnected.
39	OUT7	O	
40	VDDO5	P	Supply Voltage (1.8–3.3 V) for OUT7 Leave VDDOx pins of unused output drivers unconnected. An alternate option is to connect the VDDOx pin to a power supply and disable the output driver to minimize current consumption.
41	Ground	GND	Ground Pad This pad provides electrical and thermal connection to ground and must be connected for proper operation.

6.5 Si53354A-D01AM and Si53354BD12750-AM Pin Descriptions (40-QFN)

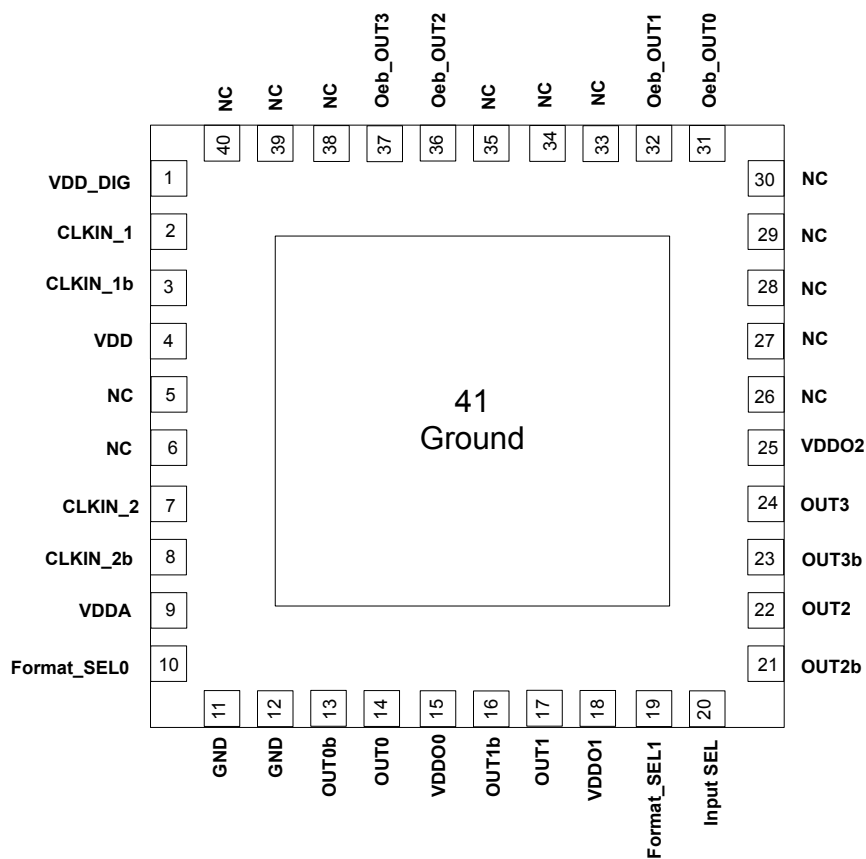

Figure 6.5. Si53354A-D01AM and Si53354BD12750-AM (40-QFN)

Table 6.5. Si53354A-D01AM and Si53354BD12750-AM Pin Descriptions (40-QFN)

Pin Number	Pin Name	Pin Type	Function
1	VDD_DIG	P	Voltage supply for digital functions. Connect to 1.8–3.3 V. Part of internal core VDD voltage. Must be connected to same voltage as VDDA and VDD.
2	CLKIN_1	I	Clock input 1. These pins accept both differential and single-ended clock signals. Refer to Section 3.4 Universal Hardware Input Pins - Input_SEL for input termination options. These pins are high-impedance and must be terminated externally. If both the CLKIN_1 and CLKIN_1b inputs are unused and powered down, then both inputs can be left floating. ClockBuilder Pro will power down an input that is set as "Unused".
3	CLKIN_1b	I	
4	VDD	P	Voltage supply. Connect to 1.8–3.3 V. Part of internal core VDD voltage. Must be connected to same voltage as VDDA and VDD_DIG.
5	NC	—	Do not connect these pins to anything.
6	NC	—	
7	CLKIN_2	I	Clock input 2. These pins accept both differential and single-ended clock signals. Refer to Section 3.4 Universal Hardware Input Pins - Input_SEL for input termination options. These pins are high-impedance and must be terminated externally. If both the CLKIN_2 and CLKIN_2b inputs are unused and powered down, then both inputs can be left floating. ClockBuilder Pro will power down an input that is set as "Unused".
8	CLKIN_2b	I	
9	VDDA	P	Core Supply Voltage. Connect to 1.8–3.3 V. Must be connected to same voltage as VDD_DIG and VDD.
10	Format_SEL0	I	Output clock format selection pin. Used in conjunction with Pin 19. Reference Section 3.2 Output Signal Formats . If using Si53350BD12750-AM, do not connect this pin to anything.
11	GND	P	Connect these pins to ground.
12	GND	P	
13	OUT0b	O	Output Clock
14	OUT0	O	These output clocks support a programmable signal swing and common mode voltage. Termination recommendations are provided in Section 3.2 Output Signal Formats . Unused outputs should be left unconnected.
15	VDDO0	P	Supply Voltage (1.8–3.3 V) for OUT0 Leave VDDOx pins of unused output drivers unconnected. An alternate option is to connect the VDDOx pin to a power supply and disable the output driver to minimize current consumption.
16	OUT1b	O	Output Clock
17	OUT1	O	These output clocks support a programmable signal swing and common mode voltage. Termination recommendations are provided in Section 3.2 Output Signal Formats . Unused outputs should be left unconnected.
18	VDDO1	P	Supply Voltage (1.8–3.3 V) for OUT1 Leave VDDOx pins of unused output drivers unconnected. An alternate option is to connect the VDDOx pin to a power supply and disable the output driver to minimize current consumption.
19	Format_SEL1	I	Output clock format selection pin. Used in conjunction with Pin 10. Reference Section 3.2 Output Signal Formats . If using Si53350BD12750-AM, do not connect this pin to anything.

Pin Number	Pin Name	Pin Type	Function
20	Input_SEL	I	Input clock selection pin. 0 = CLKIN_1/CLKIN_1b 1 = CLKIN_2/CLKIN_2b
21	OUT2b	O	Output Clock
22	OUT2	O	These output clocks support a programmable signal swing and common mode voltage. Termination recommendations are provided in Section 3.2 Output Signal Formats . Unused outputs should be left unconnected.
23	OUT3b	O	Output Clock
24	OUT3	O	These output clocks support a programmable signal swing and common mode voltage. Termination recommendations are provided in Section 3.2 Output Signal Formats . Unused outputs should be left unconnected.
25	VDDO2	P	Supply Voltage (1.8–3.3 V) for OUT2 and OUT3 Leave VDDOx pins of unused output drivers unconnected. An alternate option is to connect the VDDOx pin to a power supply and disable the output driver to minimize current consumption.
26	NC	—	Do not connect these pins to anything.
27	NC	—	
28	NC	—	
29	NC	—	Do not connect these pins to anything.
30	NC	—	
31	OEb_OUT0	I	Output enable for OUT0 0 = output enabled 1 = output disabled
32	OEb_OUT1	I	Output enable for OUT1 0 = output enabled 1 = output disabled
33	NC	—	Do not connect these pins to anything.
34	NC	—	
35	NC	—	
36	OEb_OUT2	I	Output enable for OUT2 0 = output enabled 1 = output disabled
37	OEb_OUT3	I	Output enable for OUT3 0 = output enabled 1 = output disabled
38	NC	—	Do not connect these pins to anything.
39	NC	—	
40	NC	—	Do not connect these pins to anything.

Pin Number	Pin Name	Pin Type	Function
41	Ground	GND	Ground Pad This pad provides electrical and thermal connection to ground and must be connected for proper operation.

6.6 Si53354BDxxxxx-AM Pin Descriptions (40-QFN)

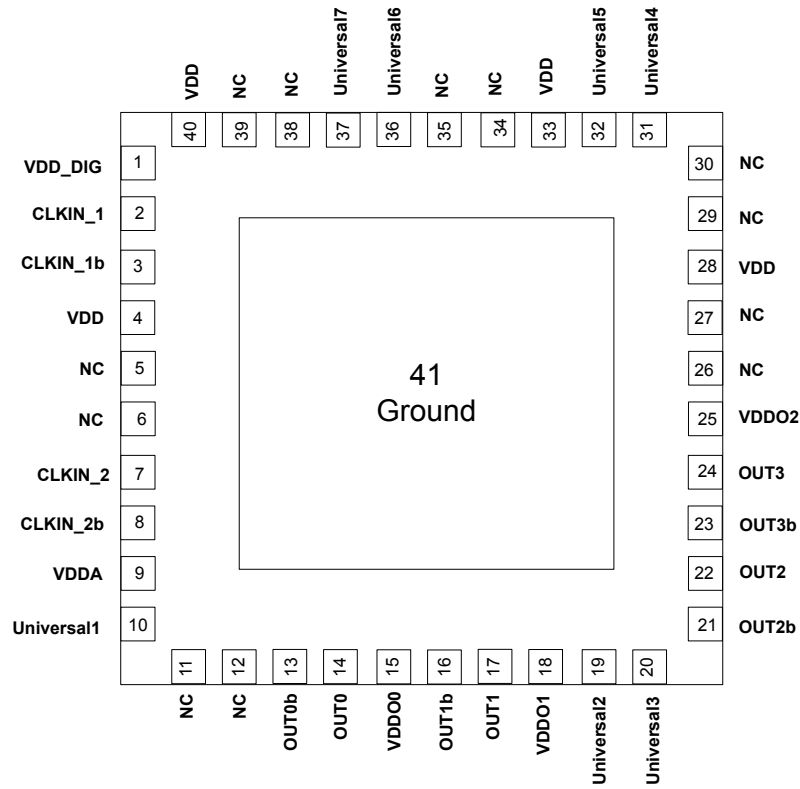

Figure 6.6. Si53354BDxxxxx-AM 40-QFN

Table 6.6. Si53354BDxxxx-AM Pin Descriptions (40-QFN)

Pin Number	Pin Name	Pin Type	Function
1	VDD_DIG	P	Voltage supply for digital functions. Connect to 1.8–3.3 V. Part of internal core VDD voltage. Must be connected to same voltage as VDDA and VDD.
2	CLKIN_1	I	Clock input 1. These pins accept both differential and single-ended clock signals. Refer to Section 3.4 Universal Hardware Input Pins - Input_SEL for input termination options. These pins are high-impedance and must be terminated externally. If both the CLKIN_1 and CLKIN_1b inputs are unused and powered down, then both inputs can be left floating. ClockBuilder Pro will power down an input that is set as "Unused".
3	CLKIN_1b	I	
4	VDD	P	Voltage supply. Connect to 1.8–3.3 V. Part of internal core VDD voltage. Must be connected to same voltage as VDDA and VDD_DIG.
5	NC	—	Do not connect these pins to anything.
6	NC	—	
7	CLKIN_2	I	Clock input 2. These pins accept both differential and single-ended clock signals. Refer to Section 3.4 Universal Hardware Input Pins - Input_SEL for input termination options. These pins are high-impedance and must be terminated externally. If both the CLKIN_2 and CLKIN_2b inputs are unused and powered down, then both inputs can be left floating. ClockBuilder Pro will power down an input that is set as "Unused".
8	CLKIN_2b	I	
9	VDDA	P	Core Supply Voltage. Connect to 1.8–3.3 V. Must be connected to same voltage as VDD_DIG.
10	Universal1	I	Universal HW pin. This hardware pin is user definable through ClockBuilder Pro. Refer to Section 3.4 Universal Hardware Input Pins for a list of definitions that hardware pins can be used for.
11	GND	P	Connect these pins to ground.
12	GND	P	
13	OUT0b	O	Output Clock
14	OUT0	O	These output clocks support a programmable signal swing and common mode voltage. Termination recommendations are provided in Section 3.2 Output Signal Formats . Unused outputs should be left unconnected.
15	VDDO0	P	Supply Voltage (1.8–3.3 V) for OUT0 Leave VDDOx pins of unused output drivers unconnected. An alternate option is to connect the VDDOx pin to a power supply and disable the output driver to minimize current consumption.
16	OUT1b	O	Output Clock
17	OUT1	O	These output clocks support a programmable signal swing and common mode voltage. Termination recommendations are provided in Section 3.2 Output Signal Formats . Unused outputs should be left unconnected.
18	VDDO1	P	Supply Voltage (1.8–3.3 V) for OUT1 Leave VDDOx pins of unused output drivers unconnected. An alternate option is to connect the VDDOx pin to a power supply and disable the output driver to minimize current consumption.
19	Universal2	I	Universal HW pin. This hardware pin is user definable through ClockBuilder Pro. Refer to Section 3.4 Universal Hardware Input Pins for a list of definitions that hardware pins can be used for.

Pin Number	Pin Name	Pin Type	Function
20	Universal3	I	Universal HW pin. This hardware pin is user definable through ClockBuilder Pro. Refer to Section 3.4 Universal Hardware Input Pins for a list of definitions that hardware pins can be used for.
21	OUT2b	O	Output Clock These output clocks support a programmable signal swing and common mode voltage. Termination recommendations are provided in Section 3.2 Output Signal Formats . Unused outputs should be left unconnected.
22	OUT2	O	
23	OUT3b	O	Output Clock These output clocks support a programmable signal swing and common mode voltage. Termination recommendations are provided in Section 3.2 Output Signal Formats . Unused outputs should be left unconnected.
24	OUT3	O	
25	VDDO2	P	Supply Voltage (1.8–3.3 V) for OUT2 and OUT3 Leave VDDOx pins of unused output drivers unconnected. An alternate option is to connect the VDDOx pin to a power supply and disable the output driver to minimize current consumption.
26	NC	—	Do not connect these pins to anything.
27	NC	—	
28	NC	—	
29	NC	—	
30	NC	—	
31	Universal4	I	Universal HW pin. This hardware pin is user definable through ClockBuilder Pro. Refer to Section 3.4 Universal Hardware Input Pins for a list of definitions that hardware pins can be used for.
32	Universal5	I	Universal HW pin. This hardware pin is user definable through ClockBuilder Pro. Refer to Section 3.4 Universal Hardware Input Pins for a list of definitions that hardware pins can be used for.
33	NC	—	Do not connect these pins to anything.
34	NC	—	
35	NC	—	
36	Universal6	I	Universal HW pin. This hardware pin is user definable through ClockBuilder Pro. Refer to Section 3.4 Universal Hardware Input Pins for a list of definitions that hardware pins can be used for.
37	Universal7	I	Universal HW pin. This hardware pin is user definable through ClockBuilder Pro. Refer to Section 3.4 Universal Hardware Input Pins for a list of definitions that hardware pins can be used for.
38	NC	—	Do not connect these pins to anything.
39	NC	—	
40	NC	—	
41	Ground	GND	Ground Pad This pad provides electrical and thermal connection to ground and must be connected for proper operation.

6.7 Si53352A-D01AM and Si53352BD12751-AM Pin Descriptions (32-QFN)

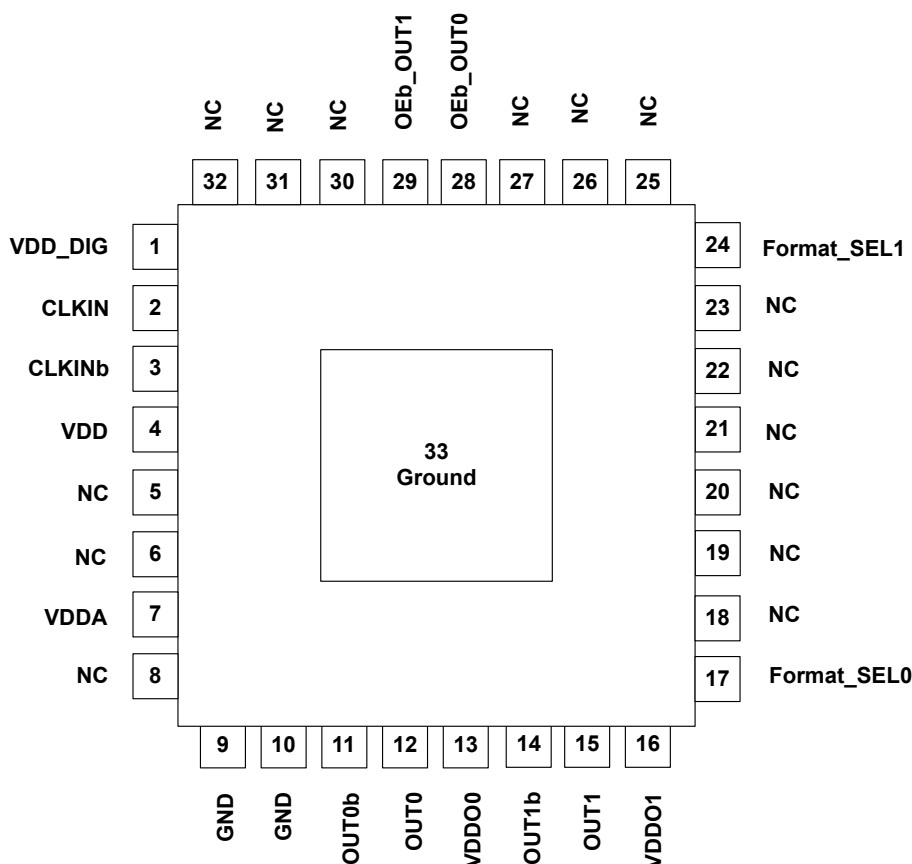

Figure 6.7. Si53352A-D01AM and Si53352BD12751-AM (32-QFN)

Table 6.7. Si53352A-D01AM and Si53352BD12751-AM Pin Descriptions (32-QFN)

Pin Number	Pin Name	Pin Type	Function
1	VDD_DIG	P	Voltage supply for digital functions. Connect to 1.8–3.3 V. Part of internal core VDD voltage. Must be connected to same voltage as VDDA.
2	CLKIN	I	Clock input. These pins accept both differential and single-ended clock signals. Refer to Section 3.4 Universal Hardware Input Pins - Input_SEL for input termination options. These pins are high-impedance and must be terminated externally. If both the CLKIN_1 and CLKIN_1b inputs are unused and powered down, then both inputs can be left floating. ClockBuilder Pro will power down an input that is set as "Unused".
3	CLKINb	I	
4	VDD	P	Voltage supply. Connect to 1.8–3.3 V. Part of internal core VDD voltage. Must be connected to same voltage as VDDA and VDD_DIG.
5	NC	—	Do not connect these pins to anything.
6	NC	—	
7	VDDA	P	Core Supply Voltage. Connect to 1.8–3.3 V. Must be connected to same voltage as VDD_DIG and VDD.
8	NC	—	Do not connect this pin to anything.
9	GND	P	Connect these pins to ground.
10	GND	P	

Pin Number	Pin Name	Pin Type	Function
11	OUT0b	O	Output Clock
12	OUT0	O	These output clocks support a programmable signal swing and common mode voltage. Termination recommendations are provided in Section 3.2 Output Signal Formats . Unused outputs should be left unconnected
13	VDDO0	P	Supply Voltage (1.8–3.3 V) for OUT0 Leave VDDOx pins of unused output drivers unconnected. An alternate option is to connect the VDDOx pin to a power supply and disable the output driver to minimize current consumption.
14	OUT1b	O	Output Clock
15	OUT1	O	These output clocks support a programmable signal swing and common mode voltage. Termination recommendations are provided in Section 3.2 Output Signal Formats . Unused outputs should be left unconnected
16	VDDO1	P	Supply Voltage (1.8–3.3 V) for OUT1 Leave VDDOx pins of unused output drivers unconnected. An alternate option is to connect the VDDOx pin to a power supply and disable the output driver to minimize current consumption.
17	Format_SEL0	I	Output clock format selection pin. Used in conjunction with Pin 17. Reference Section 3.2 Output Signal Formats . If using Si53350BD12751-AM, do not connect this pin to anything.
18	NC	—	Do not connect these pins to anything.
19	NC	—	
20	NC	—	
21	NC	—	
22	NC	—	
23	NC	—	
24	Format_SEL1	I	Output clock format selection pin. Used in conjunction with Pin 8. Reference Section 3.2 Output Signal Formats . If using Si53350BD12751-AM, do not connect this pin to anything.
25	NC	—	Do not connect these pins to anything.
26	NC	—	
27	NC	—	
28	OEb_OUT0	I	Output enable for OUT0 0 = output enabled 1 = output disabled
29	OEb_OUT1	I	Output enable for OUT1 0 = output enabled 1 = output disabled
30	NC	—	Do not connect these pins to anything.
31	NC	—	
32	NC	—	

Pin Number	Pin Name	Pin Type	Function
33	Ground	GND	Ground Pad This pad provides electrical and thermal connection to ground and must be connected for proper operation.

6.8 Si53352BDxxxx-AM Pin Descriptions (32-QFN)

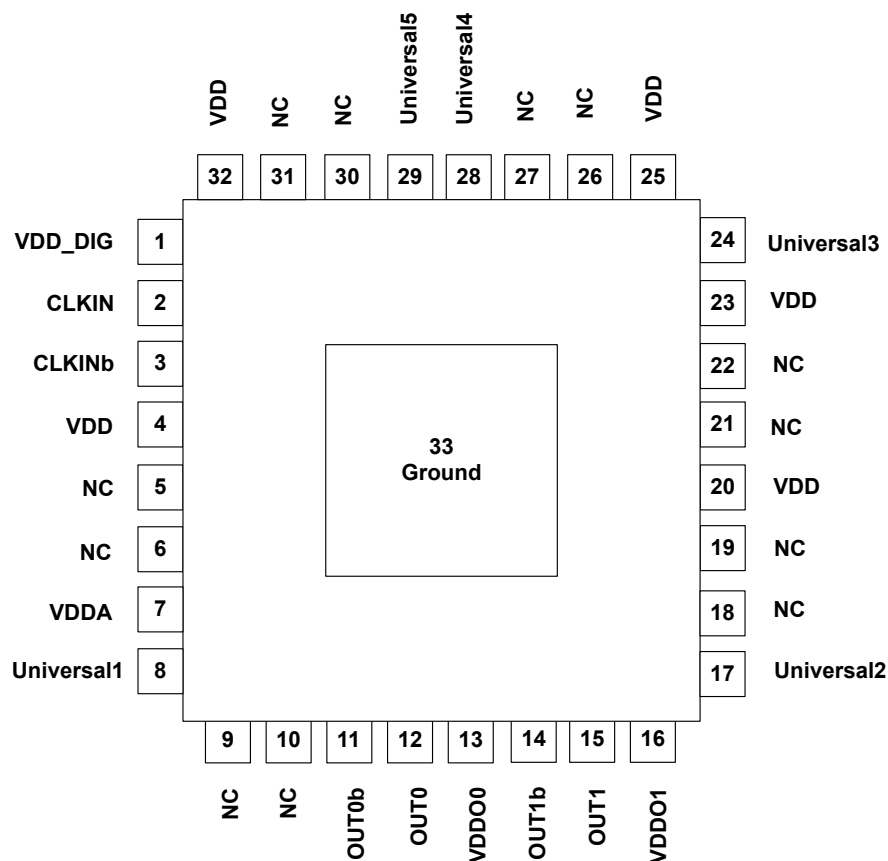

Figure 6.8. Si53352A-Dxxxx-AM 32-QFN

Table 6.8. Si53352BDxxxx-AM Pin Descriptions, (32-QFN)

Pin Number	Pin Name	Pin Type	Function
1	VDD_DIG	P	Voltage supply for digital functions. Connect to 1.8–3.3 V. Part of internal core VDD voltage. Must be connected to same voltage as VDDA.
2	CLKIN	I	Clock input. These pins accept both differential and single-ended clock signals. Refer to Section 3.4 Universal Hardware Input Pins - Input_SEL for input termination options. These pins are high-impedance and must be terminated externally. If both the CLKIN_1 and CLKIN_1b inputs are unused and powered down, then both inputs can be left floating. ClockBuilder Pro will power down an input that is set as "Unused".
3	CLKINb	I	
4	VDD	P	Voltage supply. Connect to 1.8–3.3 V. Part of internal core VDD voltage. Must be connected to same voltage as VDDA and VDD_DIG.
5	NC	—	Do not connect these pins to anything.
6	NC	—	
7	VDDA	P	Core Supply Voltage. Connect to 1.8–3.3 V. Must be connected to same voltage as VDD_DIG and VDD.
8	Universal1	I	Universal HW pin. This hardware pin is user definable through ClockBuilder Pro. Refer to Section 3.4 Universal Hardware Input Pins for a list of definitions that hardware pins can be used for.

Pin Number	Pin Name	Pin Type	Function
9	GND	P	Connect these pins to ground.
10	GND	P	
11	OUT0b	O	Output Clock
12	OUT0	O	These output clocks support a programmable signal swing and common mode voltage. Termination recommendations are provided in Section 3.2 Output Signal Formats . Unused outputs should be left unconnected.
13	VDDO0	P	Supply Voltage (1.8–3.3 V) for OUT0 Leave VDDOx pins of unused output drivers unconnected. An alternate option is to connect the VDDOx pin to a power supply and disable the output driver to minimize current consumption.
14	OUT1b	O	Output Clock
15	OUT1	O	These output clocks support a programmable signal swing and common mode voltage. Termination recommendations are provided in Section 3.2 Output Signal Formats . Unused outputs should be left unconnected.
16	VDDO1	P	Supply Voltage (1.8–3.3 V) for OUT1 Leave VDDOx pins of unused output drivers unconnected. An alternate option is to connect the VDDOx pin to a power supply and disable the output driver to minimize current consumption.
17	Universal2	I	Universal HW pin. This hardware pin is user definable through ClockBuilder Pro. Refer to Section 3.4 Universal Hardware Input Pins for a list of definitions that hardware pins can be used for.
18	NC	—	Do not connect these pins to anything.
19	NC	—	
20	NC	—	
21	NC	—	
22	NC	—	
23	NC	—	
24	Universal3	I	Universal HW pin. This hardware pin is user definable through ClockBuilder Pro. Refer to Section 3.4 Universal Hardware Input Pins for a list of definitions that hardware pins can be used for.
25	NC	—	Do not connect these pins to anything.
26	NC	—	
27	NC	—	
28	Universal4	I	Universal HW pin. This hardware pin is user definable through ClockBuilder Pro. Refer to Section 3.4 Universal Hardware Input Pins for a list of definitions that hardware pins can be used for.
29	Universal5	I	Universal HW pin. This hardware pin is user definable through ClockBuilder Pro. Refer to Section 3.4 Universal Hardware Input Pins for a list of definitions that hardware pins can be used for.
30	NC	—	Do not connect these pins to anything.
31	NC	—	
32	NC	—	

Pin Number	Pin Name	Pin Type	Function
33	Ground	GND	Ground Pad This pad provides electrical and thermal connection to ground and must be connected for proper operation.

7. Package Outline

7.1 7x7 mm 48-QFN Package Diagram

The figure below illustrates the package details for 48-QFN. The table below lists the values for the dimensions shown in the illustration.

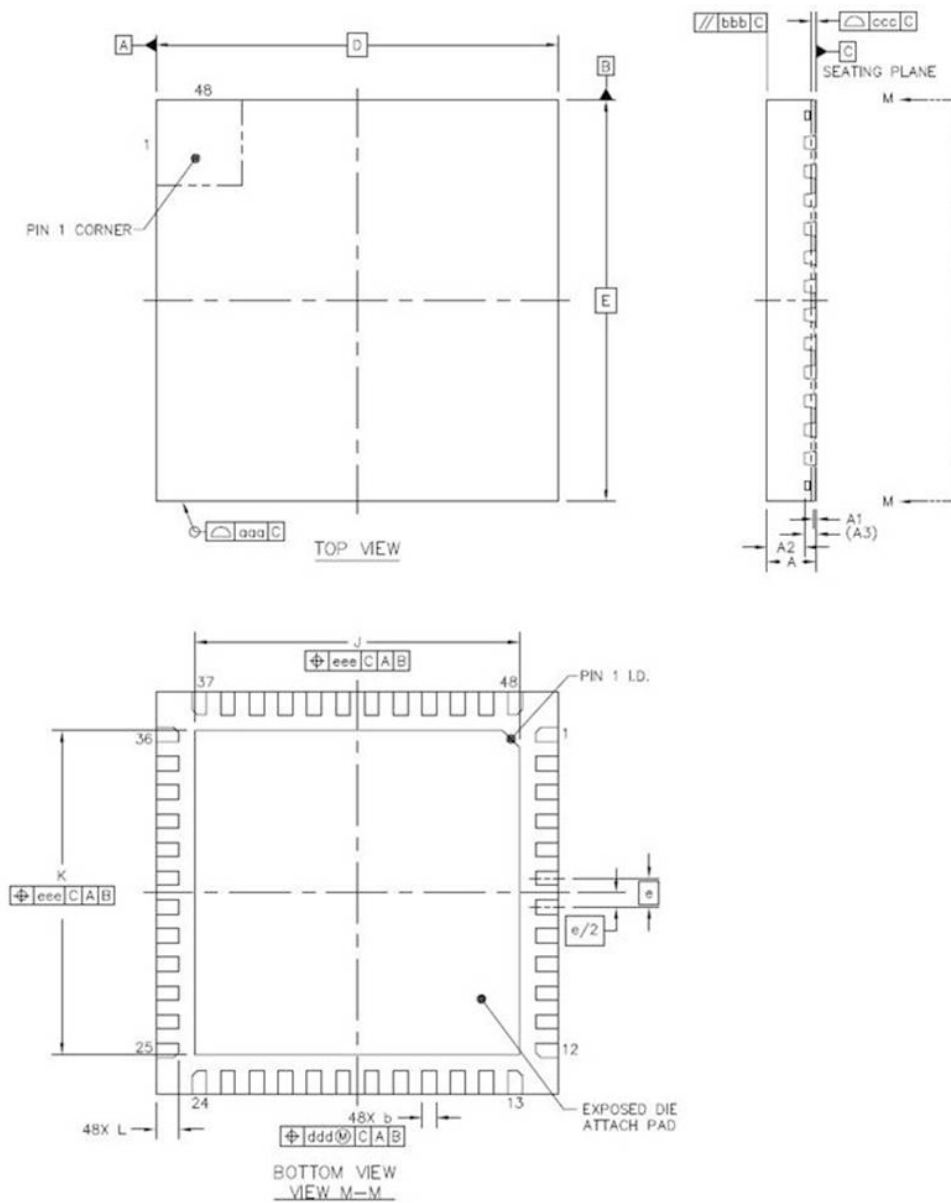

Figure 7.1. 48-Pin Quad Flat No-Lead (QFN)

Table 7.1. Package Dimensions

Dimension	Min	Nom	Max
A	0.80	0.85	0.90
A1	00	0.035	0.05
A2	--	0.65	0.67
A3	0.203 REF		
b	0.20	0.25	0.30
D	7 BSC		

Dimension	Min	Nom	Max
E	7 BSC		
e	0.5 BSC		
J	5.55	5.65	5.75
K	5.55	5.65	5.75
L	0.35	0.40	0.45
aaa	0.10		
bbb	0.10		
ccc	0.08		
ddd	0.10		
eee	0.10		

Notes:

1. All dimensions shown are in millimeters (mm) unless otherwise noted.
2. Dimensions and Tolerances per ANSI Y14.5M-1994.
3. This drawing conforms to the JEDEC Solid State Outline MO-220, Variation VLLD-5
4. Recommended card re-flow profile is per the JEDEC/IPC J-STD-020 specification for Small Body Components.

7.2 6x6 mm 40-QFN Package Diagram

The figure below illustrates the package details for 40-QFN. The table below lists the values for the dimensions shown in the illustration.

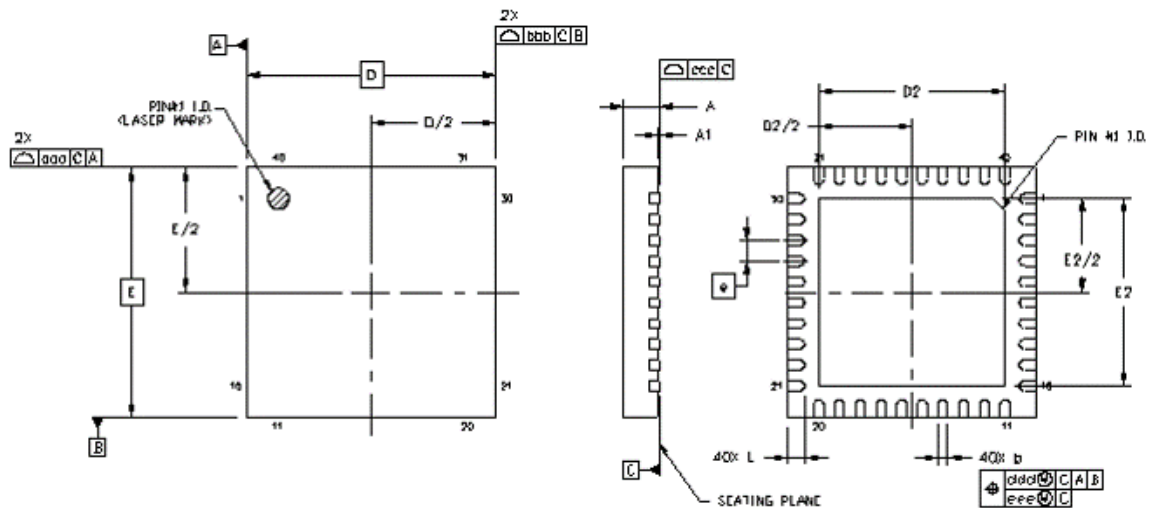

Figure 7.2. 40-Pin Quad Flat No-Lead (QFN)

Table 7.2. Package Dimensions

Dimension	Min	Nom	Max
A	0.80	0.85	0.90
A1	0.00	0.02	0.05
b	0.18	0.25	0.30
D	6.00 BSC		
D2	4.35	4.50	4.65
e	0.50 BSC		
E	6.00 BSC		
E2	4.35	4.50	4.65
L	0.30	0.40	0.50
aaa	—	—	0.15
bbb	—	—	0.15
ccc	—	—	0.08
ddd	—	—	0.10
eee	—	—	0.05

Notes:

1. All dimensions shown are in millimeters (mm) unless otherwise noted.
2. Dimensions and Tolerances per ANSI Y14.5M-1994.
3. This drawing conforms to the JEDEC Solid State Outline MO-220.
4. Recommended card re-flow profile is per the JEDEC/IPC J-STD-020 specification for Small Body Components.

7.3 5x5 mm 32-QFN Package Diagram

The figure below illustrates the package details for 32-QFN option. The table below lists the values for the dimensions shown in the illustration.

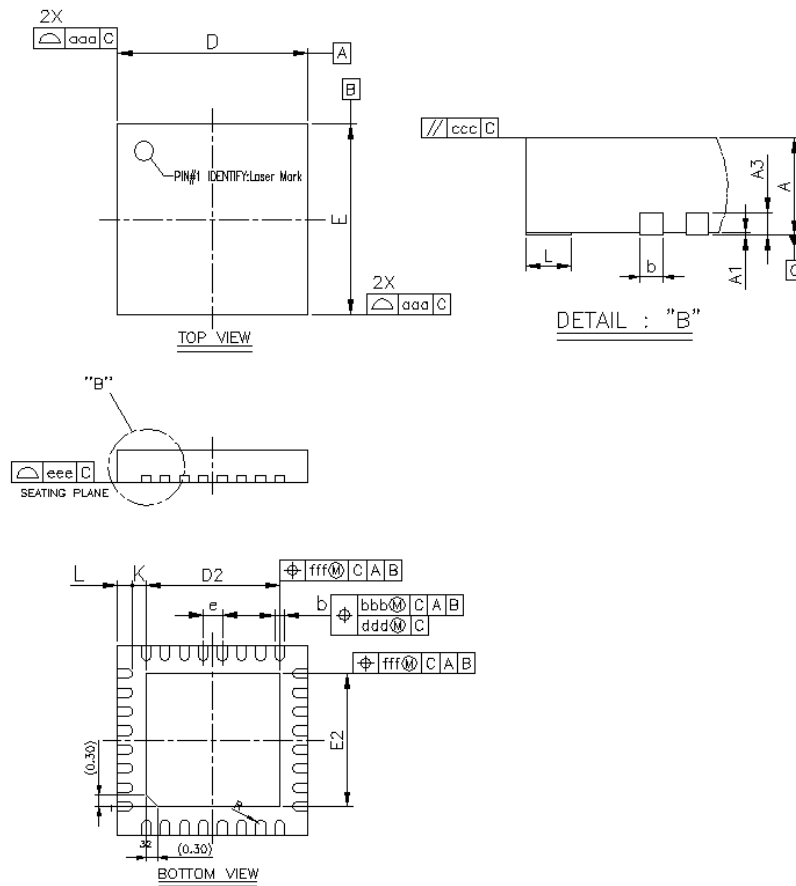

Figure 7.3. 32-Pin Quad Flat No-Lead (QFN)

Table 7.3. Package Dimensions

Dimension	MIN	NOM	MAX
A	0.80	0.85	0.90
A1	0.00	0.02	0.05
A3	0.20 REF		
b	0.18	0.25	0.30
D/E	4.90	5.00	5.10
D2/E2	3.40	3.50	3.60
e	0.50 BSC		
L	0.30	0.40	0.50
K	0.20	---	---
R	0.09	---	0.14
aaa	0.15		
bbb	0.10		
ccc	0.10		

Dimension	MIN	NOM	MAX
ddd		0.05	
eee		0.08	
fff		0.10	

Notes:

1. All dimensions shown are in millimeters (mm) unless otherwise noted.
2. Dimensions and Tolerances per ANSI Y14.5M-1994.
3. This drawing conforms to the JEDEC Solid State Outline MO-220, Variation VKKD-4.
4. Recommended card re-flow profile is per the JEDEC/IPC J-STD-020 specification for Small Body Components.

8. PCB Land Pattern

8.1 48-QFN Land Pattern

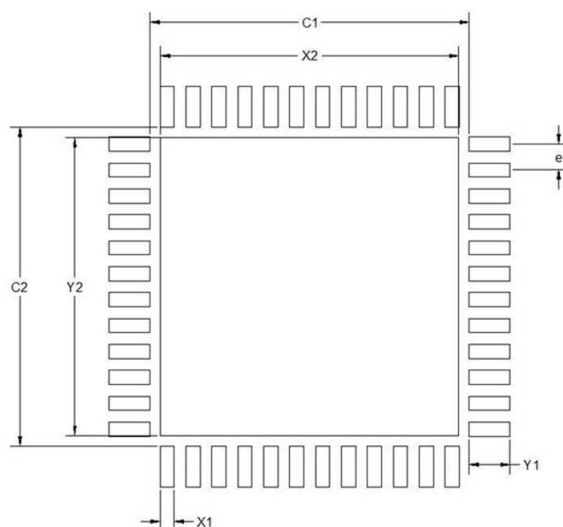

Figure 8.1. 48-QFN Land Pattern

Table 8.1. PCB Land Pattern Dimensions

Dimension	MIN	TYP	MAX
C1	6.05	6.15	6.25
C2	6.05	6.15	6.25
e	0.50 BSC		
X1	0.17	0.25	0.37
Y1	0.69	0.8	0.89
X2	5.65	5.75	5.85
Y2	5.65	5.75	5.85

Notes:

General

1. All dimensions shown are in millimeters (mm) unless otherwise noted.
2. This Land Pattern Design is based on the IPC-7351 guidelines.

Solder Mask Design

1. All metal pads are to be non-solder mask defined (NSMD). Clearance between the solder mask and the metal pad is to be 60 μm minimum, all the way around the pad.

Stencil Design

1. A stainless steel, laser-cut and electro-polished stencil with trapezoidal walls should be used to assure good solder paste release.
2. The stencil thickness should be 0.125 mm (5 mils).
3. The ratio of stencil aperture to land pad size can be 1:1 for all perimeter pads.
4. The stencil aperture to center land pad size recommendation is 70% paste coverage.

Card Assembly

1. A No-Clean, Type-3 solder paste is recommended.
2. The recommended card re-flow profile is per the JEDEC/IPC J-STD-020 specification for Small Body Components.

8.2 40-QFN Land Pattern

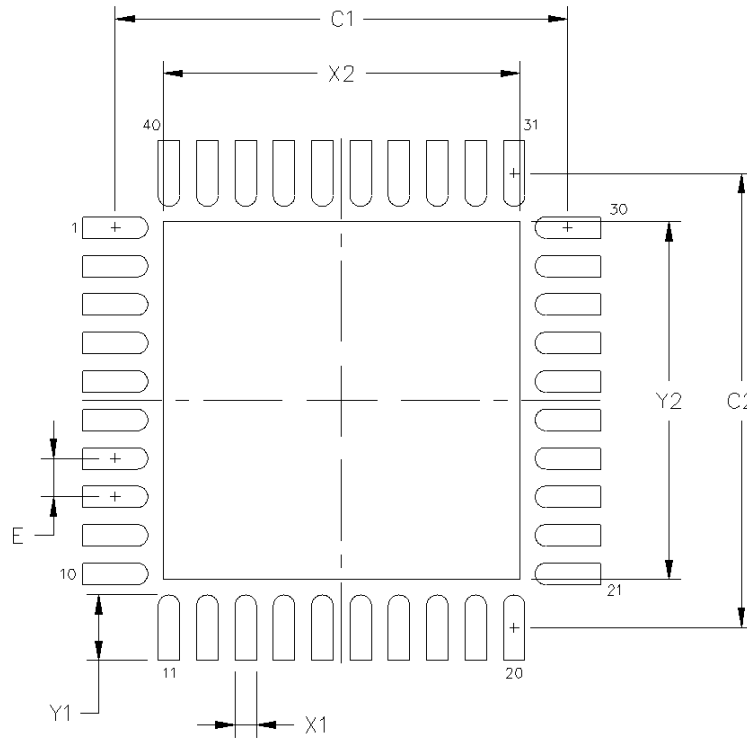

Figure 8.2. 40-QFN Land Pattern

Table 8.2. PCB Land Pattern Dimensions

Dimension	mm
C1	5.90
C2	5.90
e	0.50 BSC
X1	0.30
Y1	0.85
X2	4.65
Y2	4.65

Dimension	mm
<p>Notes:</p> <p>General</p> <ol style="list-style-type: none">1. All dimensions shown are in millimeters (mm) unless otherwise noted.2. This Land Pattern Design is based on the IPC-7351 guidelines. <p>Solder Mask Design</p> <ol style="list-style-type: none">1. All metal pads are to be non-solder mask defined (NSMD). Clearance between the solder mask and the metal pad is to be 60 μm minimum, all the way around the pad. <p>Stencil Design</p> <ol style="list-style-type: none">1. A stainless steel, laser-cut and electro-polished stencil with trapezoidal walls should be used to assure good solder paste release.2. The stencil thickness should be 0.125 mm (5 mils).3. The stencil aperture to center land pad size recommendation is 70% paste coverage.4. A 3\times3 array of 0.85 mm square openings on a 1.00 mm pitch can be used for the center ground pad. <p>Card Assembly</p> <ol style="list-style-type: none">1. A No-Clean, Type-3 solder paste is recommended.2. The recommended card re-flow profile is per the JEDEC/IPC J-STD-020 specification for Small Body Components.	

8.3 32-QFN Land Pattern

The figure below illustrates the PCB land pattern details for 32-QFN package. The table below lists the values for the dimensions shown in the illustration.

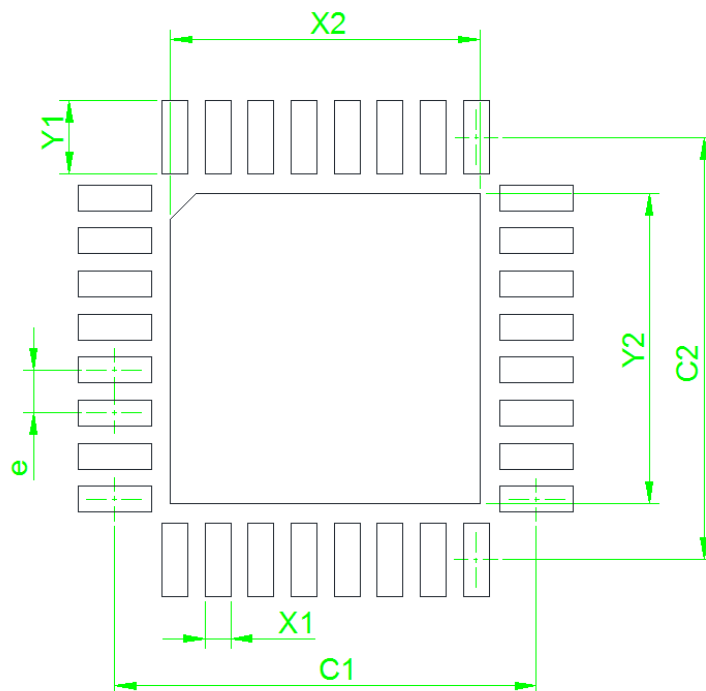

Figure 8.3. 32-QFN Land Pattern

Table 8.3. PCB Land Pattern Dimensions

Dimension	mm
C1	4.90
C2	4.90
e	0.50 BSC
X1	0.30
Y1	0.85
X2	3.60
Y2	3.60

Dimension	mm
<p>Notes:</p> <p>General</p> <ol style="list-style-type: none">1. All dimensions shown are in millimeters (mm) unless otherwise noted.2. This Land Pattern Design is based on the IPC-7351 guidelines. <p>Solder Mask Design</p> <ol style="list-style-type: none">1. All metal pads are to be non-solder mask defined (NSMD). Clearance between the solder mask and the metal pad is to be 60 μm minimum, all the way around the pad. <p>Stencil Design</p> <ol style="list-style-type: none">1. A stainless steel, laser-cut and electro-polished stencil with trapezoidal walls should be used to assure good solder paste release.2. The stencil thickness should be 0.125 mm (5 mils).3. The stencil aperture to center land pad size recommendation is 70% paste coverage.4. A 3\times3 array of 0.85 mm square openings on a 1.00 mm pitch can be used for the center ground pad. <p>Card Assembly</p> <ol style="list-style-type: none">1. A No-Clean, Type-3 solder paste is recommended.2. The recommended card re-flow profile is per the JEDEC/IPC J-STD-020 specification for Small Body Components.	

9. Top Marking

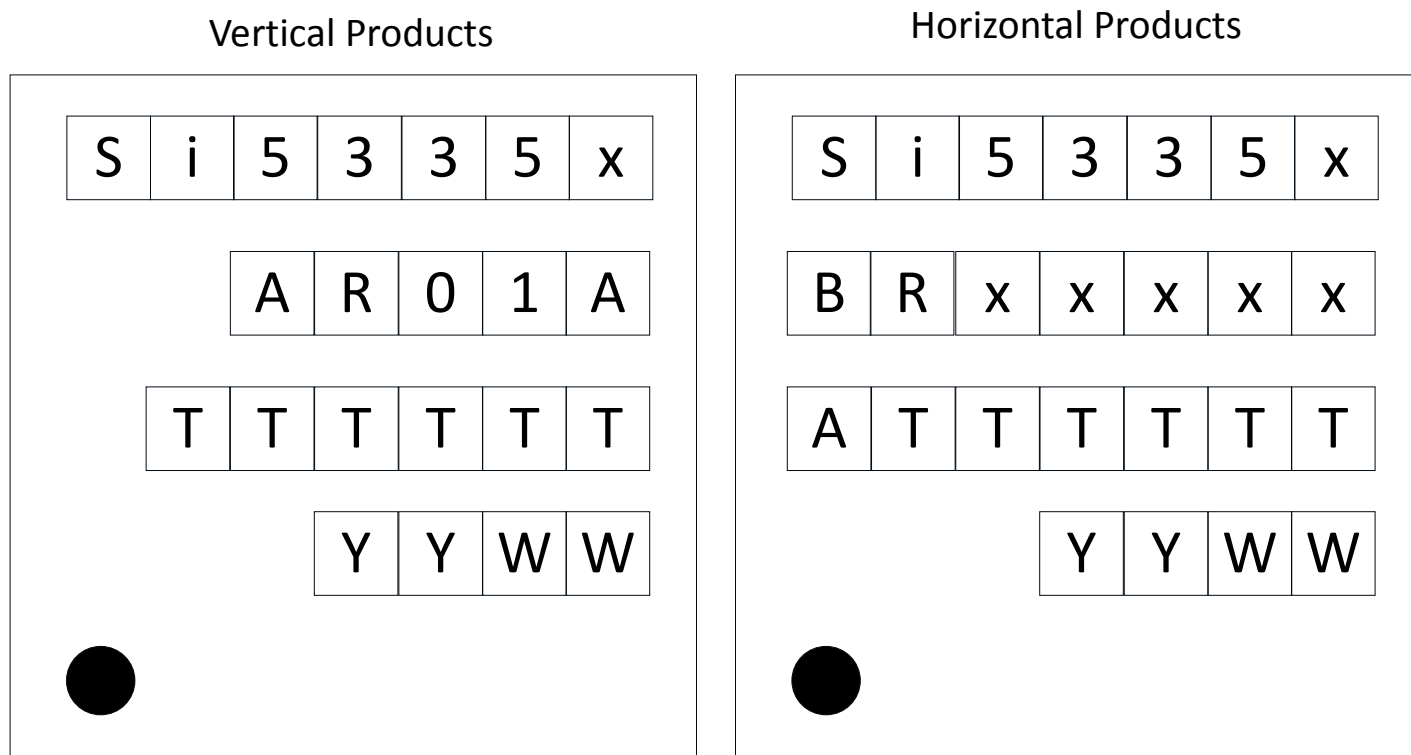

Figure 9.1. Top Marking

Table 9.1. Top Marking Explanation

Line	Characters	Description
1	Si53350 Si53358 Si53354 Si53352	Base part number
2	AR01A	A = Product grade R = Product revision (see Ordering Guide for current revision) 01 = Device ID A = Automotive temperature range (-40 °C to +105 °C) and Package (QFN)
	BDxxxx	B = Product grade R = Product revision (see Ordering Guide for current revision) XXXXX = Customer specific NVM sequence number. NVM code assigned for custom, factory pre-programmed devices using ClockBuilder Pro.
3	TTTTTT	Manufacturing trace code
	ATTTTTT	AM = Automotive temperature range (-40 °C to +105 °C) and Package (QFN) TTTTTT = Manufacturing trace code
4	YYWW	Year (YY) and work week (WW) of package assembly

10. Document Change List

Revision 1.1

March 2021

- Corrected Pin 8 and Pin10 descriptions in [Table 6.7 Si53352A-D01AM and Si53352BD12751-AM Pin Descriptions \(32-QFN\) on page 45](#) to match the pinout diagram in [Figure 6.7 Si53352A-D01AM and Si53352BD12751-AM \(32-QFN\) on page 45](#).

Revision 1.0

January 2021

- Added 10-output devices in 48-QFN.
- Updated "Inputx" pin descriptions to "Universalx".
- Added AEC-Q100 qualified.
- Added note not recommending use of LVCMOS in-phase, dual output drivers.
- Added orderable part numbers supporting complementary LVCMOS output drivers.
- Switched Format_SEL1 and Format_SEL0 columns on the table in [Section 3.2](#).

Revision 0.7

September 2019

- Initial release.

ClockBuilder Pro

One-click access to Timing tools, documentation, software, source code libraries & more. Available for Windows and iOS (CBGo only).

www.silabs.com/CBPro



IoT Portfolio
www.silabs.com/timing



SW/HW
www.silabs.com/CBPro

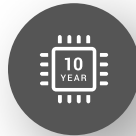

Quality
www.silabs.com/quality



Support & Community
www.silabs.com/community

Disclaimer

Silicon Labs intends to provide customers with the latest, accurate, and in-depth documentation of all peripherals and modules available for system and software implementers using or intending to use the Silicon Labs products. Characterization data, available modules and peripherals, memory sizes and memory addresses refer to each specific device, and "Typical" parameters provided can and do vary in different applications. Application examples described herein are for illustrative purposes only. Silicon Labs reserves the right to make changes without further notice to the product information, specifications, and descriptions herein, and does not give warranties as to the accuracy or completeness of the included information. Without prior notification, Silicon Labs may update product firmware during the manufacturing process for security or reliability reasons. Such changes will not alter the specifications or the performance of the product. Silicon Labs shall have no liability for the consequences of use of the information supplied in this document. This document does not imply or expressly grant any license to design or fabricate any integrated circuits. The products are not designed or authorized to be used within any FDA Class III devices, applications for which FDA premarket approval is required or Life Support Systems without the specific written consent of Silicon Labs. A "Life Support System" is any product or system intended to support or sustain life and/or health, which, if it fails, can be reasonably expected to result in significant personal injury or death. Silicon Labs products are not designed or authorized for military applications. Silicon Labs products shall under no circumstances be used in weapons of mass destruction including (but not limited to) nuclear, biological or chemical weapons, or missiles capable of delivering such weapons. Silicon Labs disclaims all express and implied warranties and shall not be responsible or liable for any injuries or damages related to use of a Silicon Labs product in such unauthorized applications.

Note: This content may contain offensive terminology that is now obsolete. Silicon Labs is replacing these terms with inclusive language wherever possible. For more information, visit www.silabs.com/about-us/inclusive-lexicon-project

Trademark Information

Silicon Laboratories Inc., Silicon Laboratories®, Silicon Labs®, SiLabs® and the Silicon Labs logo®, Bluegiga®, Bluegiga Logo®, Clockbuilder®, CMEMS®, DSPLL®, EFM®, EFM32®, EFR®, Ember®, Energy Micro, Energy Micro logo and combinations thereof, "the world's most energy friendly microcontrollers", Ember®, EZLink®, EZRadio®, EZRadioPRO®, Gecko®, Gecko OS, Gecko OS Studio, ISOModem®, Precision32®, ProSLIC®, Simplicity Studio®, SiPHY®, Telegesis, the Telegesis Logo®, USBXpress®, Zentri, the Zentri logo and Zentri DMS, Z-Wave®, and others are trademarks or registered trademarks of Silicon Labs. ARM, CORTEX, Cortex-M3 and THUMB are trademarks or registered trademarks of ARM Holdings. Keil is a registered trademark of ARM Limited. Wi-Fi is a registered trademark of the Wi-Fi Alliance. All other products or brand names mentioned herein are trademarks of their respective holders.



Silicon Laboratories Inc.
400 West Cesar Chavez
Austin, TX 78701
USA

www.silabs.com