

PCI-EXPRESS GEN 1, GEN 2, & GEN 3 FANOUT BUFFER

Features

- PCI-Express Gen 1, Gen 2, and Gen 3 compliant
- Low power push-pull type differential output buffers
- Integrated resistors on differential clocks
- Dedicated output enable pin for each buffered clocks
- Six PCI-Express Gen 1, Gen 2 & Gen 3 buffered clocks
- 100 to 210 MHz clock input range
- I²C support with readback capabilities
- Spread aware for maximum electromagnetic interference (EMI) reduction
- Industrial temperature: -40 to 85 °C
- 3.3 V power supply
- 32-pin QFN package

Applications

- Network attached storage
- Multi-function printers
- Wireless access point
- Routers

Description

The Si53156 is a spread aware PCIe clock buffer that can source six PCIe clocks simultaneously. The device has six hardware output enable control inputs for enabling the respective differential outputs on the fly while powered on along with output enable control through I²C communication. In addition to the hardware control pins, I²C programmability is also available to promptly achieve optimum clock signal integrity through skew and edge rate control on true, compliment, or both differential outputs as well as amplitude control.

Functional Block Diagram

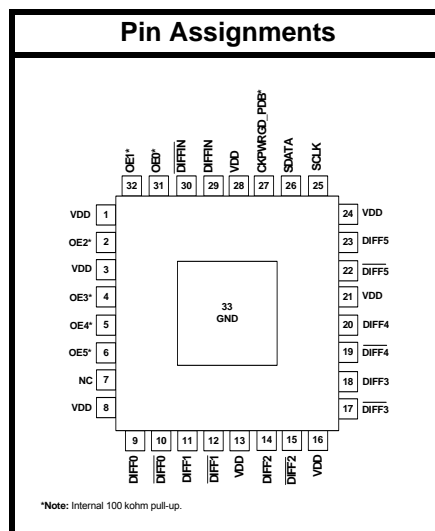
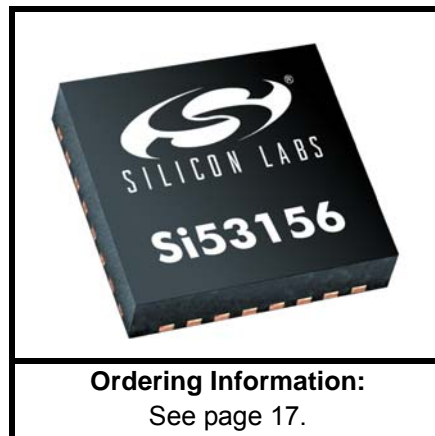
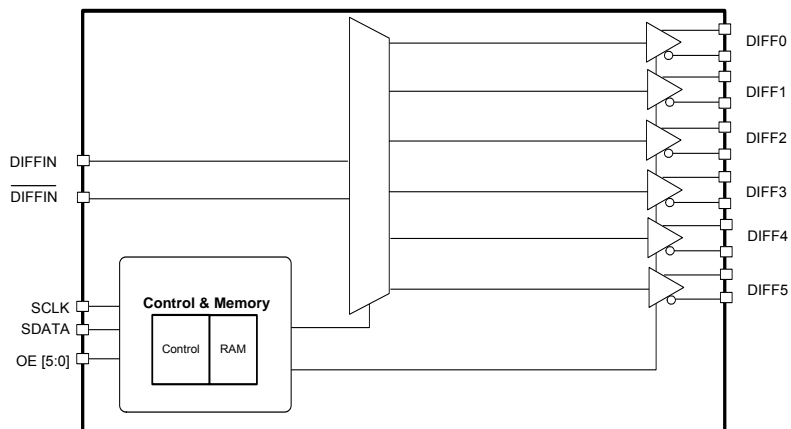

Patents pending

TABLE OF CONTENTS

<u>Section</u>	<u>Page</u>
1. Electrical Specifications	4
2. Functional Description	7
2.1. OE Clarification	7
2.2. OE Assertion	7
2.3. OE Deassertion	7
3. Test and Measurement Setup	8
4. Control Registers	10
4.1. Serial Data Interface	10
4.2. Data Protocol	10
5. Pin Descriptions: 32-Pin QFN	15
6. Ordering Guide	17
7. Package Outline	18
Contact Information	20

1. Electrical Specifications

Table 1. DC Electrical Specifications

Parameter	Symbol	Test Condition	Min	Typ	Max	Unit
3.3 V Operating Voltage	VDD core	3.3 ± 5%	3.135	—	3.465	V
3.3 V Input High Voltage	V _{IH}	Control input pins	2.0	—	V _{DD} + 0.3	V
3.3 V Input Low Voltage	V _{IL}	Control input pins	V _{SS} - 0.3	—	0.8	V
Input High Voltage	V _{IHI2C}	SDATA, SCLK	2.2	—	—	V
Input Low Voltage	V _{ILI2C}	SDATA, SCLK	—	—	1.0	V
Input High Leakage Current	I _{IH}	Except internal pull-down resistors, 0 < V _{IN} < V _{DD}	—	—	5	μA
Input Low Leakage Current	I _{IL}	Except internal pull-up resistors, 0 < V _{IN} < V _{DD}	-5	—	—	μA
High-impedance Output Current	I _{OZ}		-10	—	10	μA
Input Pin Capacitance	C _{IN}		1.5	—	5	pF
Output Pin Capacitance	C _{OUT}		—	—	6	pF
Pin Inductance	L _{IN}		—	—	7	nH
Power Down Current	I _{DD_PD}		—	—	1	mA
Dynamic Supply Current in Fanout Mode	I _{DD_3.3V}	Differential clocks with 5" traces and 2 pF load, frequency at 100 MHz	—	—	45	mA

Table 2. AC Electrical Specifications

Parameter	Symbol	Condition	Min	Typ	Max	Unit
DIFFIN at 0.7 V						
Average Period	T_{PERIOD}	Measured at crossing point V_{OX}	9.997 0	—	10.0533	ns
Absolute minimum clock periods	$T_{ABSMIN-IN}$	Measured at crossing point V_{OX}	9.872 0	—	—	ns
DIFFIN and \overline{DIFFIN} Rise and Fall Times	T_R/T_F	Single ended measurement: $V_{OL} = 0.175$ to $V_{OH} = 0.525$ V (Averaged)	0.6	—	4	V/ns
Differential Input High Voltage	V_{IH}		150	—	—	mV
Differential Input Low Voltage	V_{IL}		—	—	-150	mV
Crossing Point Voltage at 0.7 V Swing	V_{OX}	Single-ended measurement	250	—	550	mV
Vcross Variation over all edges	ΔV_{OX}	Single-ended measurement	—	—	140	mV
Differential Ringback Voltage	V_{RB}		-100	—	100	mV
Time before ringback allowed	T_{STABLE}		500	—	—	ps
Absolute maximum input voltage	V_{MAX}		—	—	1.15	V
Absolute minimum input voltage	V_{MIN}		-0.3	—	—	V
DIFFIN and \overline{DIFFIN} Duty Cycle	T_{DC}	Measured at crossing point V_{OX}	45	—	55	%
Rise/Fall Matching	T_{RFM}	Determined as a fraction of $2 \times (T_R - T_F)/(T_R + T_F)$	—	—	20	%
DIFF at 0.7 V						
DIFF Duty Cycle	T_{DC}	Measured at 0 V differential	45	—	55	%
DIFF Clock Skew	T_{SKEW}	Measured at 0 V differential	—	—	50	ps
Output PCIe Gen1 Additive REF-CLK Phase Jitter	RMS_{GEN1}	Includes PLL BW 8–16 MHz, $\zeta = 0.54$, $T_d=10$ ns, $F_{trk}=1.5$ MHz with BER=1E-12	0	—	10	ps
Output PCIe Gen2 Additive REF-CLK Phase Jitter	RMS_{GEN2}	Includes PLL BW 8–16 MHz, Jitter Peaking = 3 dB, $\zeta = 0.54$, $T_d=12$ ns, Low Band, $F < 1.5$ MHz	0	—	0.5	ps
Output PCIe Gen2 Additive REF-CLK Phase Jitter	RMS_{GEN2}	Includes PLL BW 8–16 MHz, Jitter Peaking = 3 dB, $\zeta = 0.54$, $T_d=12$ ns, High Band, 1.5 MHz $< F < Nyquist$	0	—	0.5	ps
Output PCIe Gen3 Additive REF-CLK Phase Jitter	RMS_{GEN3}	Includes PLL BW 2–4 MHz, CDR = 10 MHz)	0	—	0.10	ps

Table 2. AC Electrical Specifications (Continued)

Parameter	Symbol	Condition	Min	Typ	Max	Unit
Additive Cycle to Cycle Jitter	T_{CCJ}	In buffer mode. Measured at 0 V differential	—	—	50	ps
Long-term Accuracy	L_{ACC}	Measured at 0 V differential	—	—	100	ppm
Rising/Falling Slew rate	T_R / T_F	Measured differentially from ± 150 mV	2.5	—	8	V/ns
Crossing Point Voltage at 0.7 V Swing	V_{OX}		300	—	550	mV
Enable/Disable and Setup						
Clock Stabilization from Power-Up	T_{STABLE}		—	—	1.8	ms
Stopclock Set-up Time	T_{SS}		10.0	—	—	ns

Table 3. Absolute Maximum Conditions

Parameter	Symbol	Condition	Min	Typ	Max	Unit
Main Supply Voltage	$V_{DD_3.3V}$	Functional	—	—	4.6	V
Input Voltage	V_{IN}	Relative to V_{SS}	-0.5	—	4.6	V_{DC}
Temperature, Storage	T_S	Non-functional	-65	—	150	$^{\circ}C$
Industrial Temperature, Operating Ambient	T_A	Functional	-40	—	85	$^{\circ}C$
Commercial Temperature, Operating Ambient	T_A	Functional	0	—	85	$^{\circ}C$
Temperature, Junction	T_J	Functional	—	—	150	$^{\circ}C$
Dissipation, Junction to Case	θ_{JC}	JEDEC (JESD 51)	—	—	17	$^{\circ}C/W$
Dissipation, Junction to Ambient	θ_{JA}	JEDEC (JESD 51)	—	—	35	$^{\circ}C/W$
ESD Protection (Human Body Model)	ESD_{HBM}	JEDEC (JESD 22 - A114)	2000	—	—	V
Flammability Rating	UL-94	UL (Class)	V-0			
Moisture Sensitivity Level	MSL	JEDEC (J-STD-020)	1			
Note: Multiple Supplies: The voltage on any input or I/O pin cannot exceed the power pin during power-up. Power supply sequencing is not required.						

2. Functional Description

2.1. OE Clarification

The OE pins are active high inputs used to enable and disable the output clocks. To enable the output clock, the OE pin needs to be logic high and the I²C output enable bit needs to be logic high. There are two methods to disable the output clocks: the OE is pulled to a logic low, or the I²C enable bit is set to a logic low. The OE pins is required to be driven at all time and even though it has an internally 100 k Ω resistor.

2.2. OE Assertion

The OE signals are active high input used for synchronous stopping and starting the DIFF output clocks respectively while the rest of the clock generator continues to function. The assertion of the OE signal by making it logic high causes stopped respective DIFF output to resume normal operation. No short or stretched clock pulses are produced when the clock resumes. The maximum latency from the assertion to active outputs is no more than two to six output clock cycles.

2.3. OE Deassertion

When the OE pin is deasserted by making its logic low, the corresponding DIFF output is stopped cleanly, and the final output state is driven low.

3. Test and Measurement Setup

This diagram shows the test load configuration for the differential clock signals.

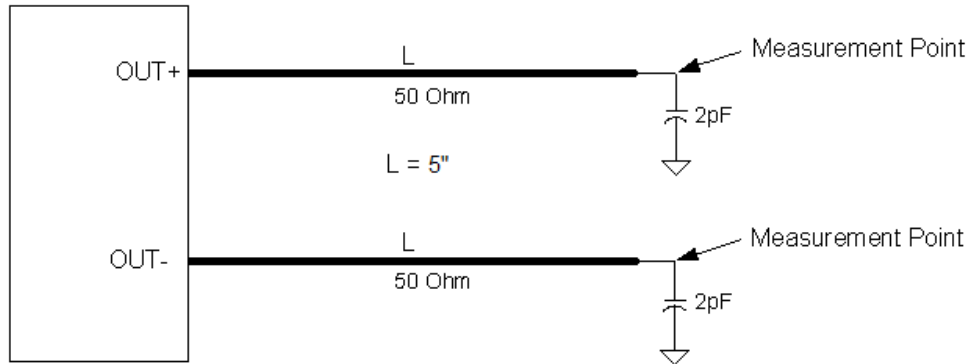

Figure 1. 0.7 V Differential Load Configuration

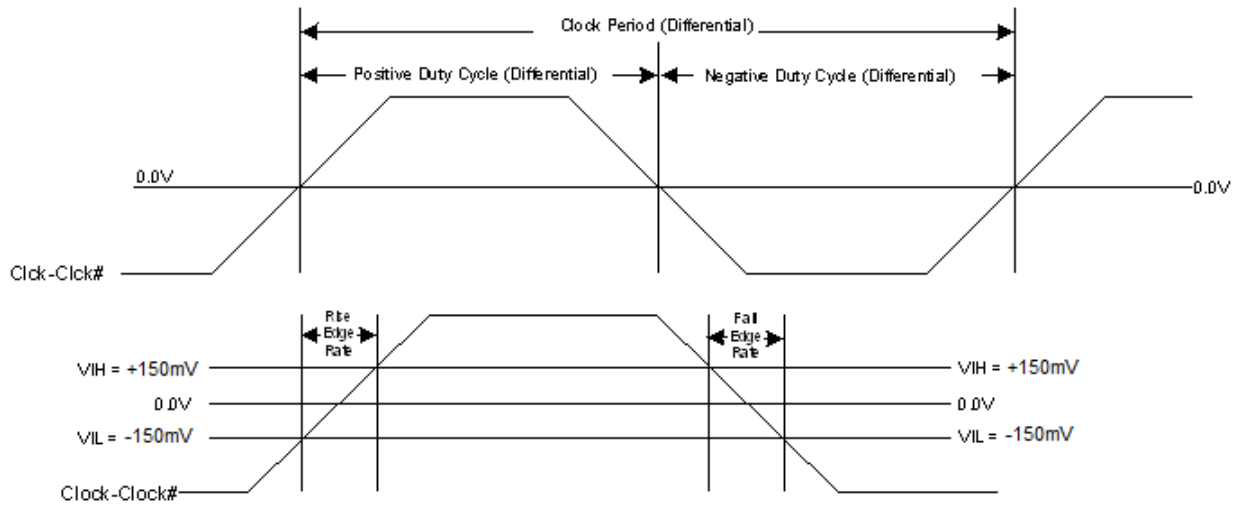

Figure 2. Differential Measurement for Differential Output Signals (for AC Parameters Measurement)

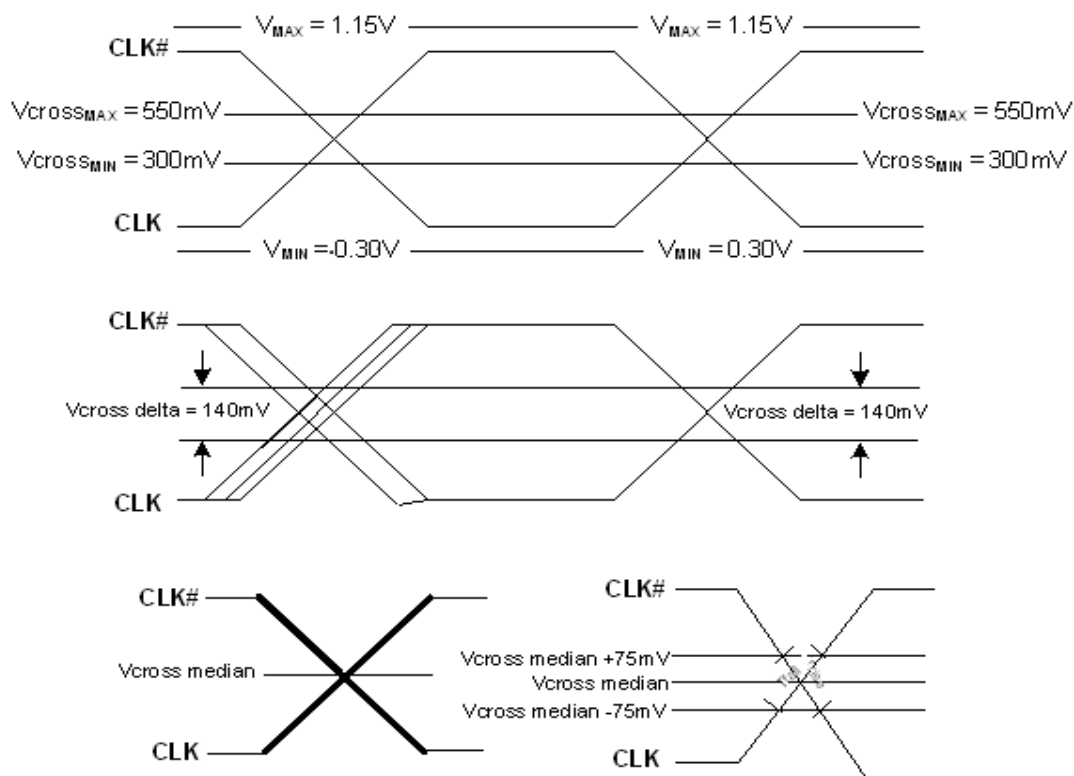

Figure 3. Single-Ended Measurement for Differential Output Signals (for AC Parameters Measurement)

4. Control Registers

4.1. Serial Data Interface

To enhance the flexibility and function of the clock synthesizer, a two-signal serial interface is provided. Through the Serial Data Interface, various device functions, such as individual clock output buffers are individually enabled or disabled. The registers associated with the Serial Data Interface initialize to their default setting at power-up. The use of this interface is optional. Clock device register changes are normally made at system initialization, if any are required. The interface cannot be used during system operation for power management functions.

4.2. Data Protocol

The clock driver serial protocol accepts byte write, byte read, block write, and block read operations from the controller. For block write/read operation, access the bytes in sequential order from lowest to highest (most significant bit first) with the ability to stop after any complete byte is transferred. For byte write and byte read operations, the system controller can access individually indexed bytes. The offset of the indexed byte is encoded in the command code described in Table 1 on page 4.

The block write and block read protocol is outlined in Table 4 on page 10 while Table 5 on page 11 outlines byte write and byte read protocol. The slave receiver address is 11010110 (D6h).

Table 4. Block Read and Block Write Protocol

Block Write Protocol		Block Read Protocol	
Bit	Description	Bit	Description
1	Start	1	Start
8:2	Slave address—7 bits	8:2	Slave address—7 bits
9	Write	9	Write
10	Acknowledge from slave	10	Acknowledge from slave
18:11	Command Code—8 bits	18:11	Command Code—8 bits
19	Acknowledge from slave	19	Acknowledge from slave
27:20	Byte Count—8 bits	20	Repeat start
28	Acknowledge from slave	27:21	Slave address—7 bits
36:29	Data byte 1—8 bits	28	Read = 1
37	Acknowledge from slave	29	Acknowledge from slave
45:38	Data byte 2—8 bits	37:30	Byte Count from slave—8 bits
46	Acknowledge from slave	38	Acknowledge
....	Data Byte/Slave Acknowledges	46:39	Data byte 1 from slave—8 bits
....	Data Byte N—8 bits	47	Acknowledge
....	Acknowledge from slave	55:48	Data byte 2 from slave—8 bits
....	Stop	56	Acknowledge
		Data bytes from slave/Acknowledge
		Data Byte N from slave—8 bits
		NOT Acknowledge
		Stop

Table 5. Byte Read and Byte Write Protocol

Byte Write Protocol		Byte Read Protocol	
Bit	Description	Bit	Description
1	Start	1	Start
8:2	Slave address–7 bits	8:2	Slave address–7 bits
9	Write	9	Write
10	Acknowledge from slave	10	Acknowledge from slave
18:11	Command Code–8 bits	18:11	Command Code–8 bits
19	Acknowledge from slave	19	Acknowledge from slave
27:20	Data byte–8 bits	20	Repeated start
28	Acknowledge from slave	27:21	Slave address–7 bits
29	Stop	28	Read
		29	Acknowledge from slave
		37:30	Data from slave–8 bits
		38	NOT Acknowledge
		39	Stop

Si53156

Control Register 0. Byte 0

Bit	D7	D6	D5	D4	D3	D2	D1	D0
Name								
Type	R/W	R/W	R/W	R/W	R/W	R/W	R/W	R/W

Reset settings = 00000000

Bit	Name	Function
7:0	Reserved	

Control Register 1. Byte 1

Bit	D7	D6	D5	D4	D3	D2	D1	D0
Name				DIFF0_OE		DIFF1_OE		DIFF2_OE
Type	R/W	R/W	R/W	R/W	R/W	R/W	R/W	R/W

Reset settings = 00010101

Bit	Name	Function
7:5	Reserved	
4	DIFF0_OE	Output Enable for DIFF0. 0: Output disabled. 1: Output Enabled.
3	Reserved	
2	DIFF1_OE	Output Enable for DIFF1. 0: Output disabled. 1: Output enabled.
1	Reserved	
0	DIFF2_OE	Output Enable for DIFF2. 0: Output disabled. 1: Output enabled.

Control Register 2. Byte 2

Bit	D7	D6	D5	D4	D3	D2	D1	D0
Name	DIFF3_OE	DIFF4_OE	DIFF5_OE					
Type	R/W	R/W	R/W	R/W	R/W	R/W	R/W	R/W

Reset settings = 11100000

Bit	Name	Function
7	DIFF3_OE	Output Enable for DIFF3. 0: Output disabled. 1: Output enabled.
6	DIFF4_OE	Output Enable for DIFF4. 0: Output disabled. 1: Output enabled.
5	DIFF5_OE	Output Enable for DIFF5. 0: Output disabled. 1: Output enabled.
4:0	Reserved	

Control Register 3. Byte 3

Bit	D7	D6	D5	D4	D3	D2	D1	D0
Name	Rev Code[3:0]				Vendor ID[3:0]			
Type	R/W	R/W	R/W	R/W	R/W	R/W	R/W	R/W

Reset settings = 00001000

Bit	Name	Function
7:4	Rev Code[3:0]	Program Revision Code.
3:0	Vendor ID[3:0]	Vendor Identification Code.

Control Register 4. Byte 4

Bit	D7	D6	D5	D4	D3	D2	D1	D0
Name	BC[7:0]							
Type	R/W	R/W	R/W	R/W	R/W	R/W	R/W	R/W

Reset settings = 00000110

Bit	Name	Function
7:0	BC[7:0]	Byte Count Register.

Control Register 5. Byte 5

Bit	D7	D6	D5	D4	D3	D2	D1	D0
Name	DIFF_Amp_Sel	DIFF_Amp_Cntl[2]	DIFF_Amp_Cntl[1]	DIFF_Amp_Cntl[0]				
Type	R/W	R/W	R/W	R/W	R/W	R/W	R/W	R/W

Reset settings = 11011000

Bit	Name	Function
7	DIFF_Amp_Sel	Amplitude Control for DIFF Differential Outputs. 0: Differential outputs with Default amplitude. 1: Differential outputs amplitude is set by Byte 5[6:4].
6	DIFF_Amp_Cntl[2]	DIFF Differential Outputs Amplitude Adjustment. 000: 300 mV 001: 400 mV 010: 500 mV 011: 600 mV 100: 700 mV 101: 800 mV 110: 900 mV 111: 1000 mV
5	DIFF_Amp_Cntl[1]	
4	DIFF_Amp_Cntl[0]	
3:0	Reserved	

5. Pin Descriptions: 32-Pin QFN

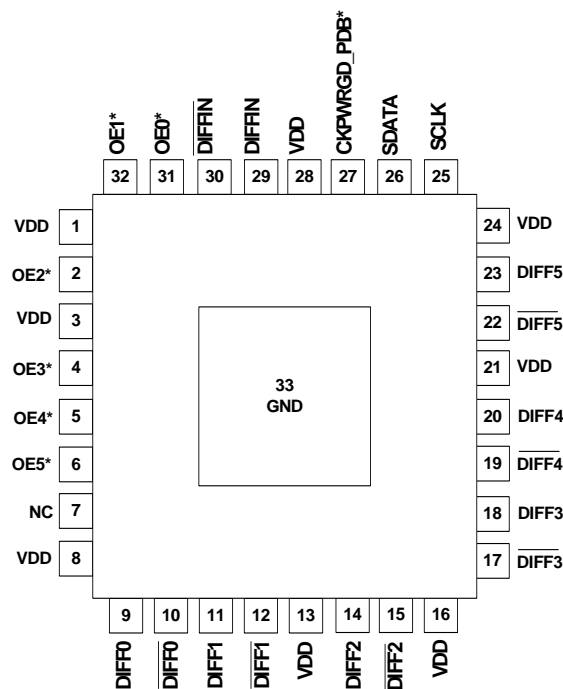

*Note: Internal 100 kohm pull-up.

Table 6. Si53156 32-Pin QFN Descriptions

Pin #	Name	Type	Description
1	VDD	PWR	3.3 V Power Supply
2	OE2	I,PU	3.3 V input to disable DIFF2 (internal 100 kΩ pull-up). Refer to Table 1 on page 4 for OE specifications.
3	VDD	PWR	3.3 V Power Supply
4	OE3	I,PU	3.3 V input to disable DIFF3 (internal 100 kΩ pull-up). Refer to Table 1 on page 4 for OE specifications.
5	OE4	I,PU	3.3 V input to disable DIFF4 (internal 100 kΩ pull-up). Refer to Table 1 on page 4 for OE specifications.
6	OE5	I,PU	3.3 V input to disable DIFF5 (internal 100 kΩ pull-up). Refer to Table 1 on page 4 for OE specifications.
7	NC	NC	No Connect
8	VDD	PWR	3.3 V Power Supply
9	DIFF0	O, DIF	0.7 V, 100 MHz differential clock
10	$\overline{\text{DIFF0}}$	O, DIF	0.7 V, 100 MHz differential clock
11	DIFF1	O, DIF	0.7 V, 100 MHz differential clock
12	$\overline{\text{DIFF1}}$	O, DIF	0.7 V, 100 MHz differential clock

Table 6. Si53156 32-Pin QFN Descriptions

Pin #	Name	Type	Description
13	VDD	PWR	3.3 V Power Supply
14	DIFF2	O, DIF	0.7 V, 100 MHz differential clock
15	$\overline{\text{DIFF2}}$	O, DIF	0.7 V, 100 MHz differential clock
16	VDD	PWR	3.3 V Power Supply
17	$\overline{\text{DIFF3}}$	O, DIF	0.7 V, 100 MHz differential clock
18	DIFF3	O, DIF	0.7 V, 100 MHz differential clock
19	$\overline{\text{DIFF4}}$	O, DIF	0.7 V, 100 MHz differential clock
20	DIFF4	O, DIF	0.7 V, 100 MHz differential clock
21	VDD	PWR	3.3 V Power Supply
22	$\overline{\text{DIFF5}}$	O, DIF	0.7 V, 100 MHz differential clock
23	DIFF5	O, DIF	0.7 V, 100 MHz differential clock
24	VDD	PWR	3.3 V Power Supply
25	SCLK	I	SMBus compatible SCLOCK
26	SDATA	I/O	SMBus compatible SDATA
27	CKPWRGD_PDB	I, PU	3.3 V LVTTTL input. This pin is a level sensitive strobe used to determine when latch inputs are valid and are ready to be sampled. A real-time active low input for asserting power down (PDB) and disabling all outputs (internal 100 k Ω pull-up).
28	VDD	PWR	3.3 V Power Supply
29	DIFFIN	I	0.7 V Differential True Input, typically 100 MHz. Input frequency range 100 to 210 MHz.
30	$\overline{\text{DIFFIN}}$	O	0.7 V Differential Complement Input, typically 100 MHz. Input frequency range 100 to 210 MHz.
31	OE0	I,PU	3.3 V input to disable DIFF0 (internal 100 k Ω pull-up). Refer to Table 1 on page 4 for OE specifications.
32	OE1	I,PU	3.3 V input to disable DIFF1 (internal 100 k Ω pull-up). Refer to Table 1 on page 4 for OE specifications.
33	GND	GND	Ground for bottom pad of the IC.

6. Ordering Guide

Part Number	Package Type	Temperature
Lead-free		
Si53156-A01AGM	32-pin QFN	Industrial, -40 to 85 °C
Si53156-A01AGMR	32-pin QFN—Tape and Reel	Industrial, -40 to 85 °C

7. Package Outline

Figure 4 illustrates the package details for the Si53156. Table 7 lists the values for the dimensions shown in the illustration.

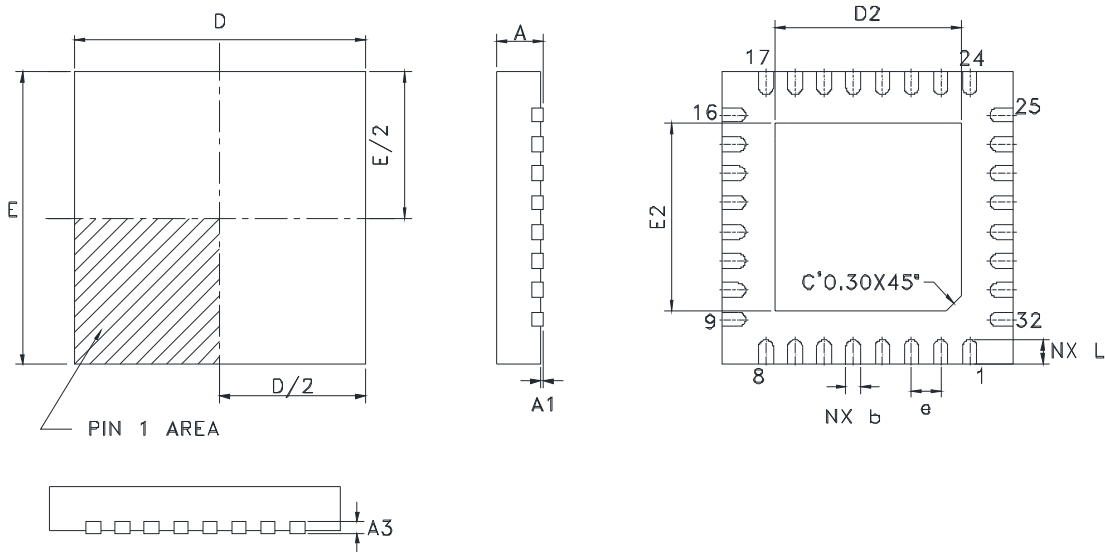

Figure 4. 32-Pin Quad Flat No Lead (QFN) Package

Table 7. Package Diagram Dimensions

Symbol	Millimeters		
	Min	Nom	Max
A	0.70	0.75	0.80
A1	0.00	0.02	0.05
A3	0.175	0.20	0.225
b	0.20	0.25	0.30
D	4.90	5.00	5.10
D2	3.15	3.20	3.25
e	0.50 BSC		
E	4.90	5.00	5.10
E2	3.15	3.20	3.25
L	0.30	0.40	0.50

Notes:

1. All dimensions shown are in millimeters (mm) unless otherwise noted.
2. Dimensioning and Tolerancing per ANSI Y14.5M-1994.
3. Recommended card reflow profile is per the JEDEC/IPC J-STD-020 specification for Small Body Components.
4. Coplanarity less than 0.08 mm.
5. Terminal #1 identifier and terminal numbering convention conform to JESD 95-1 SPP-012.

NOTES:

CONTACT INFORMATION

Silicon Laboratories Inc.

400 West Cesar Chavez
Austin, TX 78701
Tel: 1+(512) 416-8500
Fax: 1+(512) 416-9669
Toll Free: 1+(877) 444-3032

Please visit the Silicon Labs Technical Support web page:
<https://www.silabs.com/support/pages/contacttechnicalsupport.aspx>
and register to submit a technical support request.

The information in this document is believed to be accurate in all respects at the time of publication but is subject to change without notice. Silicon Laboratories assumes no responsibility for errors and omissions, and disclaims responsibility for any consequences resulting from the use of information included herein. Additionally, Silicon Laboratories assumes no responsibility for the functioning of undescribed features or parameters. Silicon Laboratories reserves the right to make changes without further notice. Silicon Laboratories makes no warranty, representation or guarantee regarding the suitability of its products for any particular purpose, nor does Silicon Laboratories assume any liability arising out of the application or use of any product or circuit, and specifically disclaims any and all liability, including without limitation consequential or incidental damages. Silicon Laboratories products are not designed, intended, or authorized for use in applications intended to support or sustain life, or for any other application in which the failure of the Silicon Laboratories product could create a situation where personal injury or death may occur. Should Buyer purchase or use Silicon Laboratories products for any such unintended or unauthorized application, Buyer shall indemnify and hold Silicon Laboratories harmless against all claims and damages.

Silicon Laboratories and Silicon Labs are trademarks of Silicon Laboratories Inc.
Other products or brandnames mentioned herein are trademarks or registered trademarks of their respective holders.