

PCI-EXPRESS GEN 1, GEN 2, & GEN 3 QUAD OUTPUT CLOCK GENERATOR

Features

- PCI-Express Gen 1, Gen 2 & Gen 3 compliant
- Supports Serial ATA (SATA) at 100 MHz
- Low power, differential outputs
- No termination resistors required
- Dedicated output enable hardware pins for each clock
- Dedicated hardware pin for spread spectrum control
- Four PCI-Express clocks
- 25 MHz crystal input or clock input
- Signal integrity tuning
- I²C support with readback capabilities
- Triangular spread spectrum profile for maximum electromagnetic interference (EMI) reduction
- Extended temperature -40 to 85 °C
- 3.3 V power supply
- 24-pin QFN package

Applications

- Network attached storage
- Multi-function printer
- Wireless access point
- Routers

Description

The Si52144 is a spread-spectrum enabled PCIe clock generator that can source four PCIe clocks. The device has four hardware output enable pins for enabling the outputs, and one hardware pin to control spread spectrum on PCIe clock outputs. In addition to the hardware control pins, I²C programmability is also available to dynamically control skew, edge rate and amplitude on the true, compliment, or both differential signals on the PCIe clock outputs. This control feature enables optimal signal integrity as well as optimal EMI signature on the PCIe clock outputs. Refer to AN636 for signal integrity and configurability.

Functional Block Diagram

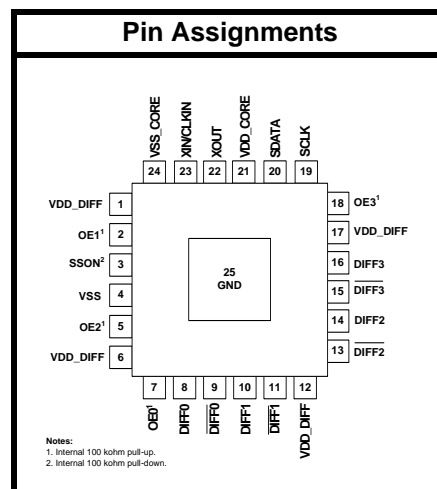
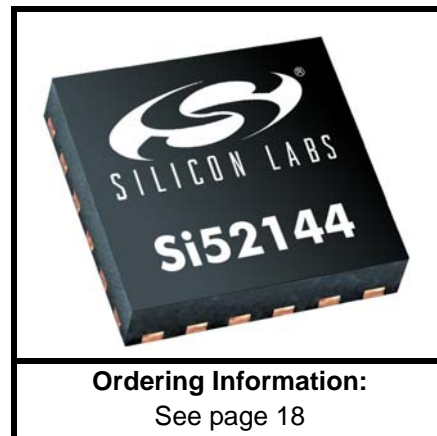
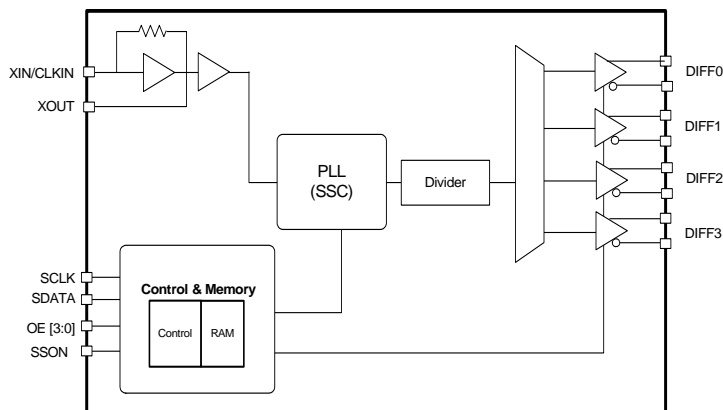

Patents pending

TABLE OF CONTENTS

<u>Section</u>	<u>Page</u>
1. Electrical Specifications	4
2. Functional Description	7
2.1. Crystal Recommendations	7
2.2. OE Pin Definition	8
2.3. OE Assertion	8
2.4. OE Deassertion	8
2.5. SSON Pin Definition	8
3. Test and Measurement Setup	9
4. Control Registers	11
4.1. I ² C Interface	11
4.2. Data Protocol	11
5. Pin Descriptions: 24-Pin QFN	16
6. Ordering Guide	18
7. Package Outline	19
Document Change List	20
Contact Information	22

1. Electrical Specifications

Table 1. DC Electrical Specifications

Parameter	Symbol	Test Condition	Min	Typ	Max	Unit
3.3 V Operating Voltage	VDD core	3.3 ±5%	3.135	3.3	3.465	V
3.3 V Input High Voltage	V _{IH}	Control input pins	2.0	—	V _{DD} + 0.3	V
3.3 V Input Low Voltage	V _{IL}	Control input pins	V _{SS} - 0.3	—	0.8	V
Input High Voltage	V _{IHI2C}	SDATA, SCLK	2.2	—	—	V
Input Low Voltage	V _{ILI2C}	SDATA, SCLK	—	—	1.0	V
Input High Leakage Current	I _{IH}	Except internal pull-down resistors, 0 < V _{IN} < V _{DD}	—	—	5	μA
Input Low Leakage Current	I _{IL}	Except internal pull-up resistors, 0 < V _{IN} < V _{DD}	-5	—	—	μA
High-impedance Output Current	I _{OZ}		-10	—	10	μA
Input Pin Capacitance	C _{IN}		1.5	—	5	pF
Output Pin Capacitance	C _{OUT}		—	—	6	pF
Pin Inductance	L _{IN}		—	—	7	nH
Dynamic Supply Current	I _{DD_3.3V}	All outputs enabled. Differential clocks with 5" traces and 2 pF load.	—	—	50	mA

Table 2. AC Electrical Specifications

Parameter	Symbol	Condition	Min	Typ	Max	Unit
Crystal						
Long-term Accuracy	L_{ACC}	Measured at $V_{DD}/2$ differential	—	—	250	ppm
Clock Input						
Duty Cycle	T_{DC}	Measured at $V_{DD}/2$	45	—	55	%
CLKIN Rising and Falling Slew Rate	T_R/T_F	Measured between $0.2 V_{DD}$ and $0.8 V_{DD}$	0.5	—	4.0	V/ns
Cycle to Cycle Jitter	T_{CCJ}	Measured at $V_{DD}/2$	—	—	250	ps
Long Term Jitter	T_{LTJ}	Measured at $V_{DD}/2$	—	—	350	ps
Input High Voltage	V_{IH}	XIN/CLKIN pin	2	—	$V_{DD}+0.3$	V
Input Low Voltage	V_{IL}	XIN/CLKIN pin	—	—	0.8	V
Input High Current	I_{IH}	XIN/CLKIN pin, $V_{IN} = V_{DD}$	—	—	35	uA
Input Low Current	I_{IL}	XIN/CLKIN pin, $0 < V_{IN} < 0.8$	-35	—	—	uA
DIFF at 0.7 V						
Duty Cycle	T_{DC}	Measured at 0 V differential	45	—	55	%
Any Clock Skew from the Earliest Bank to the Latest Bank	T_{SKEW}	Measured at 0 V differential	—	—	50	ps
Cycle to Cycle Jitter	T_{CCJ}	Measured at 0 V differential	—	35	50	ps
PCIe Gen 1 Pk-Pk Jitter	Pk-Pk	PCIe Gen 1	0	40	86	ps
PCIe Gen 2 Phase Jitter	RMS_{GEN2}	$10 \text{ kHz} < F < 1.5 \text{ MHz}$	0	2	3.0	ps
		$1.5 \text{ MHz} < F < \text{Nyquist Rate}$	0	2	3.1	ps
PCIe Gen 3 Phase Jitter	RMS_{GEN3}	Includes PLL BW 2–4 MHz (CDR = 10 MHz)	0	0.5	1.0	ps
Long Term Accuracy	L_{ACC}	Measured at 0 V differential	—	—	100	ppm
Rising/Falling Slew Rate	T_R/T_F	Measured differentially from $\pm 150 \text{ mV}$	1	—	8	V/ns
Voltage High	V_{HIGH}		—	—	1.15	V
Voltage Low	V_{LOW}		-0.3	—	—	V
Crossing Point Voltage at 0.7 V Swing	V_{OX}		300	—	550	mV
Spread Range	SPR	Down spread	—	-0.5	—	%
Modulation Frequency	F_{MOD}		30	31.5	33	kHz
Enable/Disable and Setup						
Clock Stabilization from Power-up	T_{STABLE}		—	—	1.8	ms
Stopclock Set-up Time	T_{SS}		10.0	—	—	ns
Note: Visit www.pcisig.com for complete PCIe specifications.						

Table 3. Absolute Maximum Conditions

Parameter	Symbol	Condition	Min	Typ	Max	Unit
Main Supply Voltage	$V_{DD_3.3V}$	Functional	—	—	4.6	V
Input Voltage	V_{IN}	Relative to V_{SS}	-0.5	—	4.6	V_{DC}
Temperature, Storage	T_S	Non-functional	-65	—	150	°C
Temperature, Operating Ambient	T_A	Functional	-40	—	85	°C
Temperature, Junction	T_J	Functional	—	—	150	°C
Dissipation, Junction to Case	θ_{JC}	JEDEC (JESD 51)	—	—	35	°C/W
Dissipation, Junction to Ambient	θ_{JA}	JEDEC (JESD 51)	—	—	37	°C/W
ESD Protection (Human Body Model)	ESD_{HBM}	JEDEC (JESD 22-A114)	2000	—	—	V
Flammability Rating	UL-94	UL (Class)	V-0			
Moisture Sensitivity Level	MSL	JEDEC (J-STD-020)	2			
Note: While using multiple power supplies, the voltage on any input or I/O pin cannot exceed the power pin during power-up. Power supply sequencing is not required.						

2. Functional Description

2.1. Crystal Recommendations

The clock device requires a parallel resonance crystal.

Table 4. Crystal Recommendations

Frequency (Fund)	Cut	Loading	Load Cap	Shunt Cap (max)	Motional (max)	Tolerance (max)	Stability (max)	Aging (max)
25 MHz	AT	Parallel	12–15 pF	5 pF	0.016 pF	35 ppm	30 ppm	5 ppm

2.1.1. Crystal Loading

Crystal loading is critical for ppm accuracy. In order to achieve low/zero ppm error, use the calculations in “2.1.2. Calculating Load Capacitors” to estimate the appropriate capacitive loading (CL).

Figure 1 shows a typical crystal configuration using the two trim capacitors. It is important that the trim capacitors are in series with the crystal.

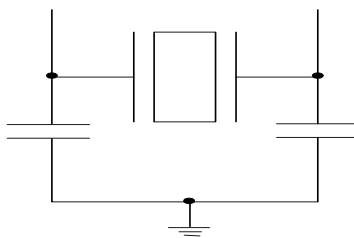

Figure 1. Crystal Capacitive Clarification

2.1.2. Calculating Load Capacitors

In addition to the standard external trim capacitors, consider the trace capacitance and pin capacitance to calculate the crystal loading correctly. Again, the capacitance on each side is in series with the crystal. The total capacitance on both side is twice the specified crystal load capacitance (CL). Trim capacitors are calculated to provide equal capacitive loading on both sides.

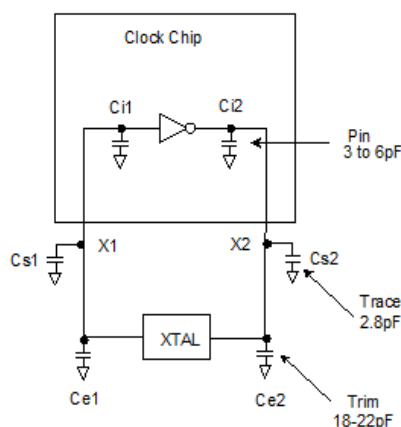

Figure 2. Crystal Loading Example

Use the following formulas to calculate the trim capacitor values for Ce1 and Ce2.

Load Capacitance (each side)

$$C_e = 2 \times CL - (C_s + C_i)$$

Total Capacitance (as seen by the crystal)

$$CL_e = \frac{1}{\left(\frac{1}{C_{e1} + C_{s1} + C_{i1}} + \frac{1}{C_{e2} + C_{s2} + C_{i2}} \right)}$$

- CL: Crystal load capacitance
- CL_e: Actual loading seen by crystal using standard value trim capacitors
- C_e: External trim capacitors
- C_s: Stray capacitance (terraced)
- C_i: Internal capacitance (lead frame, bond wires, etc.)

2.2. OE Pin Definition

The OE pins are active high inputs used to enable and disable the output clocks. To enable the output clock, the OE pin needs to be logic high and the I²C output enable bit needs to be logic high. There are two methods to disable the output clocks: the OE is pulled to a logic low, or the I²C enable bit is set to a logic low. The OE pins is required to be driven at all time and even though it has an internally 100 kΩ resistor.

2.3. OE Assertion

The OE signals are active high input used for synchronous stopping and starting the DIFF output clocks respectively while the rest of the clock generator continues to function. The assertion of the OE signal by making it logic high causes stopped respective DIFF output to resume normal operation. No short or stretched clock pulses are produced when the clock resumes. The maximum latency from the assertion to active outputs is no more than two to six output clock cycles.

2.4. OE Deassertion

When the OE pin is deasserted by making its logic low, the corresponding DIFF output is stopped cleanly, and the final output state is driven low.

2.5. SSON Pin Definition

SSON is an active input used to enable –0.5% spread on all DIFF outputs. When sampled high, –0.5% spread is enabled on all DIFF outputs. When sampled low, the DIFF output frequencies are non-spread.

3. Test and Measurement Setup

This diagram shows the test load configuration for the differential clock signals.

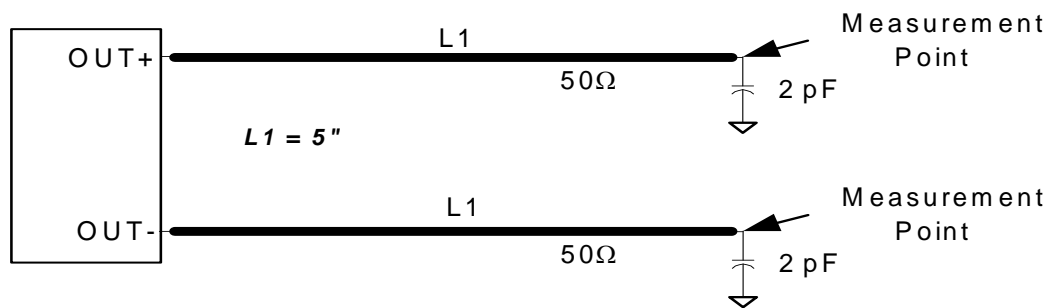

Figure 3. 0.7 V Differential Load Configuration

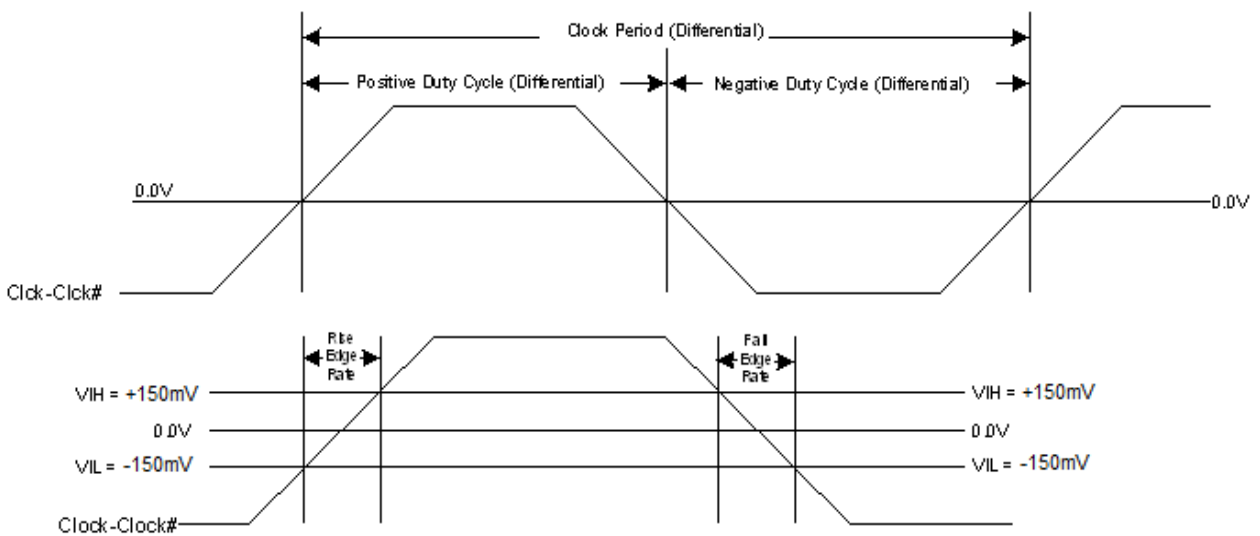

Figure 4. Differential Measurement for Differential Output Signals (for AC Parameters Measurement)

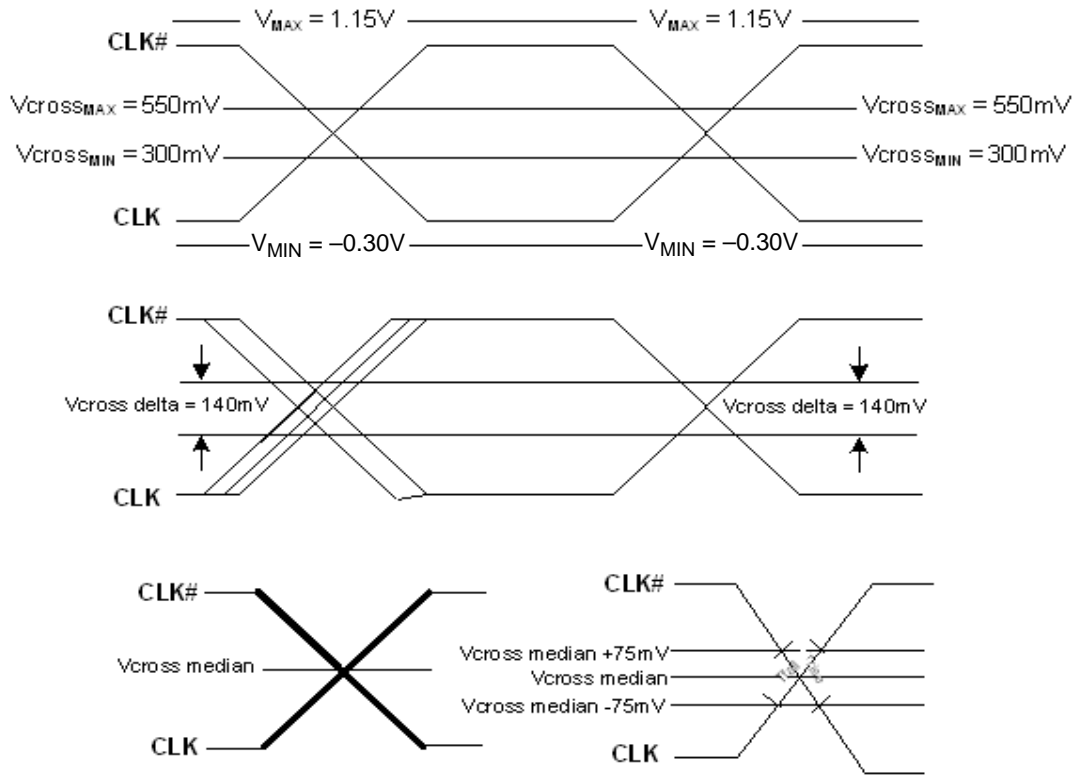

Figure 5. Single-Ended Measurement for Differential Output Signals (for AC Parameters Measurement)

4. Control Registers

4.1. I²C Interface

To enhance the flexibility and function of the clock synthesizer, an I²C interface is provided. Through the Serial Data Interface, various device functions, such as individual clock output buffers are individually enabled or disabled. The registers associated with the I²C Interface initialize to their default setting at power-up. The use of this interface is optional. Clock device register changes are normally made at system initialization, if any are required. Power management functions can only be programmed in program mode and not in normal operation modes.

4.2. Data Protocol

The clock driver I²C protocol accepts byte write, byte read, block write, and block read operations from the controller. For block write/read operation, access the bytes in sequential order from lowest to highest (most significant bit first) with the ability to stop after any complete byte is transferred. For byte write and byte read operations, the system controller can access individually indexed bytes.

The block write and block read protocol is outlined in Table 5 while Table 6 outlines byte write and byte read protocol. The slave receiver address is 11010110 (D6h).

Table 5. Block Read and Block Write Protocol

Block Write Protocol		Block Read Protocol	
Bit	Description	Bit	Description
1	Start	1	Start
8:2	Slave address—7 bits	8:2	Slave address—7 bits
9	Write	9	Write
10	Acknowledge from slave	10	Acknowledge from slave
18:11	Command Code—8 bits	18:11	Command Code—8 bits
19	Acknowledge from slave	19	Acknowledge from slave
27:20	Byte Count—8 bits	20	Repeat start
28	Acknowledge from slave	27:21	Slave address—7 bits
36:29	Data byte 1—8 bits	28	Read = 1
37	Acknowledge from slave	29	Acknowledge from slave
45:38	Data byte 2—8 bits	37:30	Byte Count from slave—8 bits
46	Acknowledge from slave	38	Acknowledge
....	Data Byte/Slave Acknowledges	46:39	Data byte 1 from slave—8 bits
....	Data Byte N—8 bits	47	Acknowledge
....	Acknowledge from slave	55:48	Data byte 2 from slave—8 bits
....	Stop	56	Acknowledge
		Data bytes from slave/Acknowledge
		Data Byte N from slave—8 bits
		NOT Acknowledge
		Stop

Table 6. Byte Read and Byte Write Protocol

Byte Write Protocol		Byte Read Protocol	
Bit	Description	Bit	Description
1	Start	1	Start
8:2	Slave address–7 bits	8:2	Slave address–7 bits
9	Write	9	Write
10	Acknowledge from slave	10	Acknowledge from slave
18:11	Command Code–8 bits	18:11	Command Code–8 bits
19	Acknowledge from slave	19	Acknowledge from slave
27:20	Data byte–8 bits	20	Repeated start
28	Acknowledge from slave	27:21	Slave address–7 bits
29	Stop	28	Read
		29	Acknowledge from slave
		37:30	Data from slave–8 bits
		38	NOT Acknowledge
		39	Stop

Control Register 0. Byte 0

Bit	D7	D6	D5	D4	D3	D2	D1	D0
Name								
Type	R/W	R/W	R/W	R/W	R/W	R/W	R/W	R/W

Reset settings = 00000000

Bit	Name	Function
7:0	Reserved	

Register 1. Byte 1

Bit	D7	D6	D5	D4	D3	D2	D1	D0
Name						DIFF0_OE		DIFF1_OE
Type	R/W	R/W	R/W	R/W	R/W	R/W	R/W	R/W

Reset settings = 00000101

Bit	Name	Function
7:3	Reserved	
2	DIFF0_OE	Output Enable for DIFF0. 0: Output disabled. 1: Output enabled.
1	Reserved	
0	DIFF1_OE	Output Enable for DIFF1. 0: Output disabled. 1: Output enabled.

Si52144

Register 2. Byte 2

Bit	D7	D6	D5	D4	D3	D2	D1	D0
Name	DIFF2_OE	DIFF3_OE						
Type	R/W	R/W	R/W	R/W	R/W	R/W	R/W	R/W

Reset settings = 11000000

Bit	Name	Function
7	DIFF2_OE	Output Enable for DIFF2. 0: Output disabled. 1: Output enabled.
6	DIFF3_OE	Output Enable for DIFF3. 0: Output disabled. 1: Output enabled.
5:0	Reserved	

Register 3. Byte 3

Bit	D7	D6	D5	D4	D3	D2	D1	D0
Name	Rev Code[3:0]				Vendor ID[3:0]			
Type	R/W	R/W	R/W	R/W	R/W	R/W	R/W	R/W

Reset settings = 00001000

Bit	Name	Function
7:4	Rev Code[3:0]	Program Revision Code.
3:0	Vendor ID[3:0]	Vendor Identification Code.

Register 4. Byte 4

Bit	D7	D6	D5	D4	D3	D2	D1	D0
Name	BC[7:0]							
Type	R/W	R/W	R/W	R/W	R/W	R/W	R/W	R/W

Reset settings = 00000110

Bit	Name	Function
7:0	BC[7:0]	Byte Count Register.

Control Register 5. Byte 5

Bit	D7	D6	D5	D4	D3	D2	D1	D0
Name	DIFF_Amp_Sel	DIFF_Amp_Cntl[2]	DIFF_Amp_Cntl[1]	DIFF_Amp_Cntl[0]				
Type	R/W	R/W	R/W	R/W	R/W	R/W	R/W	R/W

Reset settings = 11011000

Bit	Name	Function
7	DIFF_Amp_Sel	Amplitude Control for DIFF Differential Outputs. 0: Differential outputs with Default amplitude. 1: Differential outputs amplitude is set by Byte 5[6:4].
6	DIFF_Amp_Cntl[2]	DIFF Differential Outputs Amplitude Adjustment. 000: 300 mV 001: 400 mV 010: 500 mV 011: 600 mV 100: 700 mV 101: 800 mV 110: 900 mV 111: 1000 mV
5	DIFF_Amp_Cntl[1]	
4	DIFF_Amp_Cntl[0]	
3:0	Reserved	

5. Pin Descriptions: 24-Pin QFN

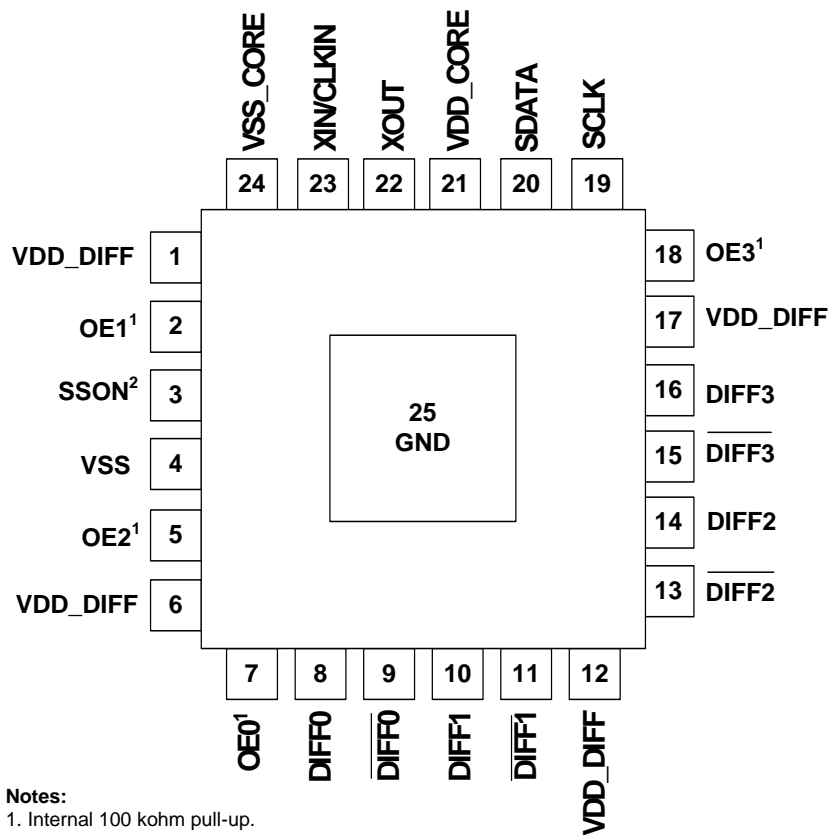

Table 7. Si52144 24-Pin QFN Descriptions

Pin #	Name	Type	Description
1	VDD_DIFF	PWR	3.3 V power supply.
2	OE1	I,PU	Active high input pin to enable or disable DIFF1 clock (internal 100 kΩ pull-down).
3	SSON	I,PD	3.3 V input for Spread Control (internal 100 kΩ pull-down).
4	VSS	GND	Ground.
5	OE2	I,PU	Active high input pin to enable or disable DIFF2 clock (internal 100 kΩ pull-down).
6	VDD_DIFF	PWR	3.3 V power supply.
7	OE0	I,PU	Active high input pin to enable or disable DIFF0 clock (internal 100 kΩ pull-down).
8	DIFF0	O, DIF	0.7 V, 100 MHz differential clock.
9	$\overline{\text{DIFF0}}$	O, DIF	0.7 V, 100 MHz differential clock.
10	DIFF1	O, DIF	0.7 V, 100 MHz differential clock.

Table 7. Si52144 24-Pin QFN Descriptions

Pin #	Name	Type	Description
11	$\overline{\text{DIFF1}}$	O, DIF	0.7 V, 100 MHz differential clock.
12	VDD_DIFF	PWR	3.3 V power supply.
13	$\overline{\text{DIFF2}}$	O, DIF	0.7 V, 100 MHz differential clock.
14	DIFF2	O, DIF	0.7 V, 100 MHz differential clock.
15	$\overline{\text{DIFF3}}$	O, DIF	0.7 V, 100 MHz differential clock.
16	DIFF3	O, DIF	0.7 V, 100 MHz differential clock.
17	VDD_DIFF	PWR	3.3 V power supply.
18	OE3	I,PU	Active high input pin to enable or disable DIFF3 clock (internal 100 k Ω pull-down).
19	SCLK	I	I ² C SCLOCK.
20	SDATA	I/O	I ² C SDATA.
21	VDD_CORE	PWR	3.3 V power supply.
22	XOUT	O	25.00 MHz crystal output, Float XOUT if using only CLKIN (clock input).
23	XIN/CLKIN	I	25.00 MHz crystal input or 3.3 V, 25 MHz clock Input.
24	VSS_CORE	GND	Ground.
25	GND	GND	Ground for bottom pad of the IC.

Si52144

6. Ordering Guide

Part Number	Package Type	Temperature
Lead-free		
Si52144-A01AGM	24-pin QFN	Extended, -40 to 85 °C
Si52144-A01AGMR	24-pin QFN—Tape and Reel	Extended, -40 to 85 °C

DOCUMENT CHANGE LIST

Revision 0.1 to Revision 1.0

- Updated Features on page 1.
- Updated Description on page 1.
- Updated Table 1 on page 4.
- Updated Table 2 on page 5.
- Updated Section 2.1 on page 7.
- Updated Section 2.1.1 on page 7.
- Updated Section 4.1 on page 11.
- Updated Section 4.2 on page 11.
- Updated Pin Descriptions on page 16.

NOTES:

CONTACT INFORMATION

Silicon Laboratories Inc.

400 West Cesar Chavez
Austin, TX 78701
Tel: 1+(512) 416-8500
Fax: 1+(512) 416-9669
Toll Free: 1+(877) 444-3032

Please visit the Silicon Labs Technical Support web page:
<https://www.silabs.com/support/pages/contacttechnicalsupport.aspx>
and register to submit a technical support request.

The information in this document is believed to be accurate in all respects at the time of publication but is subject to change without notice. Silicon Laboratories assumes no responsibility for errors and omissions, and disclaims responsibility for any consequences resulting from the use of information included herein. Additionally, Silicon Laboratories assumes no responsibility for the functioning of undescribed features or parameters. Silicon Laboratories reserves the right to make changes without further notice. Silicon Laboratories makes no warranty, representation or guarantee regarding the suitability of its products for any particular purpose, nor does Silicon Laboratories assume any liability arising out of the application or use of any product or circuit, and specifically disclaims any and all liability, including without limitation consequential or incidental damages. Silicon Laboratories products are not designed, intended, or authorized for use in applications intended to support or sustain life, or for any other application in which the failure of the Silicon Laboratories product could create a situation where personal injury or death may occur. Should Buyer purchase or use Silicon Laboratories products for any such unintended or unauthorized application, Buyer shall indemnify and hold Silicon Laboratories harmless against all claims and damages.

Silicon Laboratories and Silicon Labs are trademarks of Silicon Laboratories Inc.
Other products or brandnames mentioned herein are trademarks or registered trademarks of their respective holders.