Si4731 DEMO BOARD USER'S GUIDE

1. Features

- Worldwide FM band support, 76–108 MHz
- Worldwide AM band support, 520–1710 kHz
- Auto seek/auto scan
- 48 FM and 48 AM station presets
- FM Radio Data Services (RDS) decoding (Pi Pty Ps RT CT AF displays)
- Automatic set time/date function via RDS
- Automatic Alternative Frequency (AF) switching
- Automatic AM channel spacing detection
- Single battery operation down to 0.9 V or three battery operation
- Adjustable parameters include
 - Tuning spacing
 - Seek SNR/RSSI thresholds
 - Soft mute SNR/RSSI thresholds
 - Channel filters
 - Stereo and mono blend thresholds
 - Band limits
 - De-emphasis (50 or 75 μ s)
 - AM channel spacing detection threshold
- Stereo/mono indicator
- Volume control with mute function
- AM/FM band and signal quality indicator display
- Battery voltage indicator
- Calendar display
- 3x4 matrix keypad interface
- Direct input of station frequencies

2. Overview

The Silicon Laboratories Si4731-DEMO board provides a complete portable AM/FM radio design with numerous enhanced features that demonstrate the capabilities of the Silicon Laboratories AM/FM and MCU product families. The Si4731-DEMO comes in a 3x3 mm 20-pin QFN package and is layout compatible with the entire Silicon Labs Si47xx radio family of FM receivers, transmitters, and transceivers. The host MCU is a Silicon Laboratories C8051F930 with internal oscillator and built-in DC-DC converter. A 79 x 101 dot matrix LCD provides the flexibility to display a variety of system information including RDS. The demo board can work with either one AA battery using the dc-dc converter of the C8051F930 MCU or three AAA batteries.

Si4731-DEMO

3. Description

Figure 1 and Figure 2 shows the physical layout of the board with key components indicated.

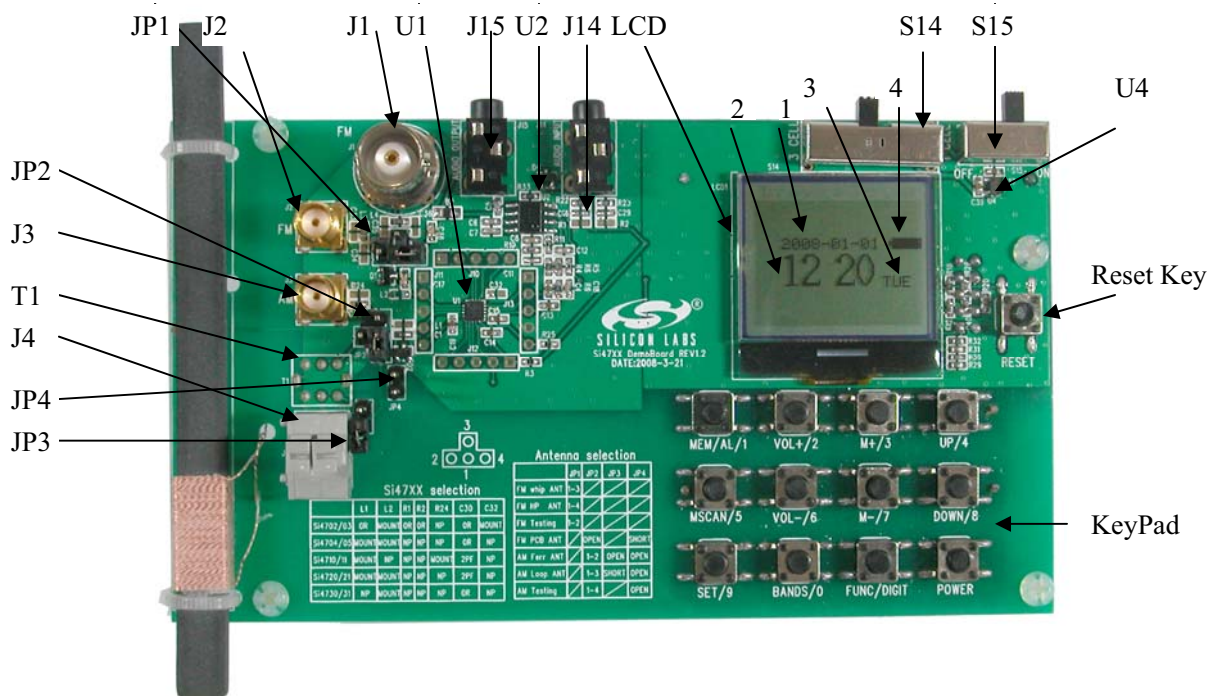

Figure 1. Si4731-DEMO Board Top Side in Calendar Mode

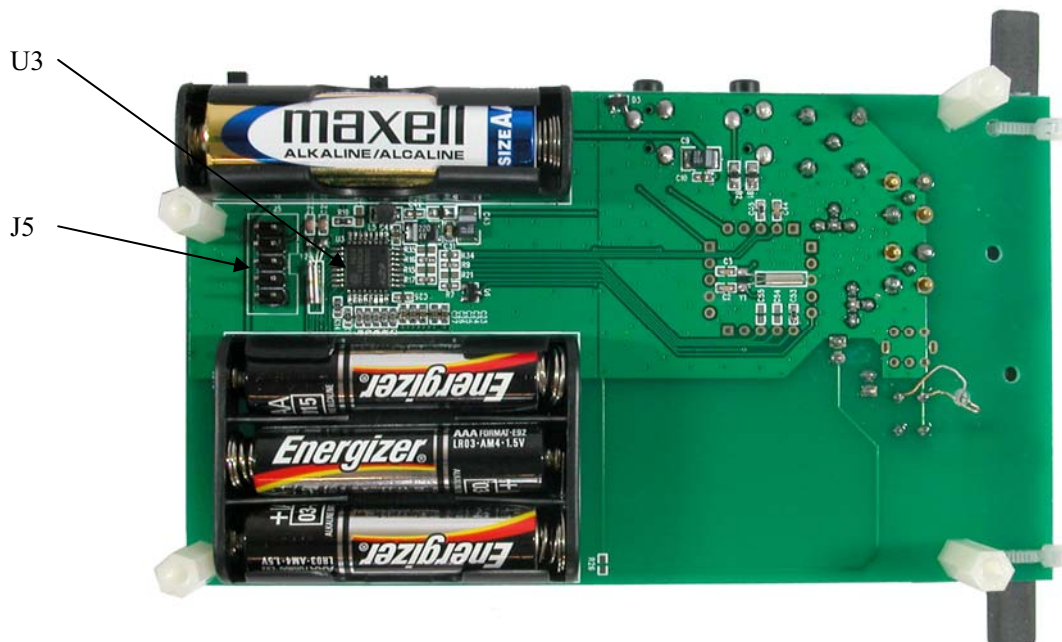

Figure 2. Si4731-DEMO Board Bottom Side

Power:

S14: 3 cell / 1 cell selection

S15: Power on / off

Audio connectors:

J14: Audio input (unused)

J15: Audio headphone output

Antenna selections:

J1: FM whip antenna connector

J2: FM SMA connector for FM conductive testing

J3: AM SMA connector for AM conductive testing

J4: AM air loop antenna wire connector

J5: JTAG connector

T1: Transformer for AM air loop operation (not shown)

JP1: FM antenna input selection

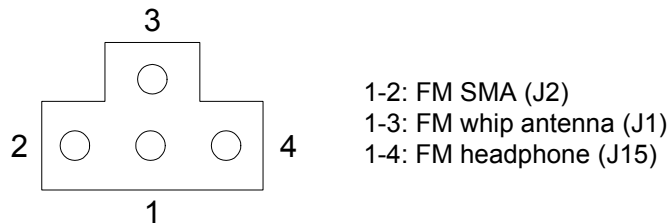

JP2: AM signal input selection

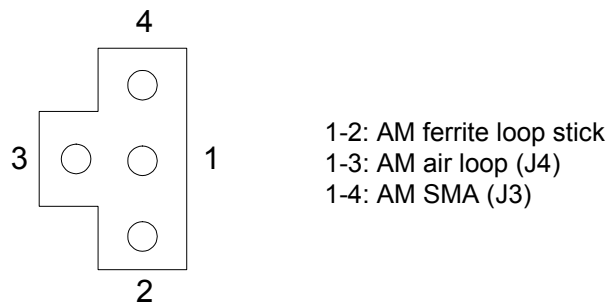

JP3: AM antenna type selection

Open: AM ferrite loop stick antenna

Short: AM air loop antenna

JP4: FM PCB antenna selection

Short: Embedded PCB trace as FM short antenna for Si4704/05/1x/2x

Open: No PCB short antenna

Main components:

LCD: 79x101 dot matrix LCD

U1: Silicon Laboratories Si4731 AM/FM/RDS tuner

U2: Audio amplifier

U3: Silicon Laboratories C8051F930 MCU

U4: LDO

Control interface:

Reset Key: Reset button

KeyPad: 3x4 matrix buttons for human interface

Si4731-DEMO

4. Operation

This section describes the operating modes of the Si4731-DEMO board. The board provides two major modes of operation: Calendar and AM/FM radio.

4.1. Calendar Mode

Upon power on, the board automatically enters the Calendar Mode and displays the following information:

- Year-month-day
- Hour-minute
- Day of the week
- Battery voltage

The demo board display in Calendar Mode is illustrated in Figure 1.

In Calendar Mode, the SET/9 key is used to enter the setup menu. The M+/3 and M-/7 keys are used to select different adjustable items (hour, minutes, year, day, month). The UP/4 and DOWN/8 keys are used to set the value for each selected item.

The Calendar Mode date and time can also be set automatically with RDS Current Time (CT) information from a broadcast radio station as described in the following section.

4.2. AM/FM Radio Mode

From Calendar Mode, the POWER button is used to enter AM/FM Radio Mode which displays the following information:

1. Signal SNR indicator
2. Signal RSSI indicator
3. Band frequency indicator
4. Battery voltage indicator
5. Band frequency unit indicator
6. Stereo/mono indicator
7. Volume indicator
8. Band indicator
9. RDS information

The demo board display in AM/FM Radio Mode is illustrated in Figure 3 and Figure 4:

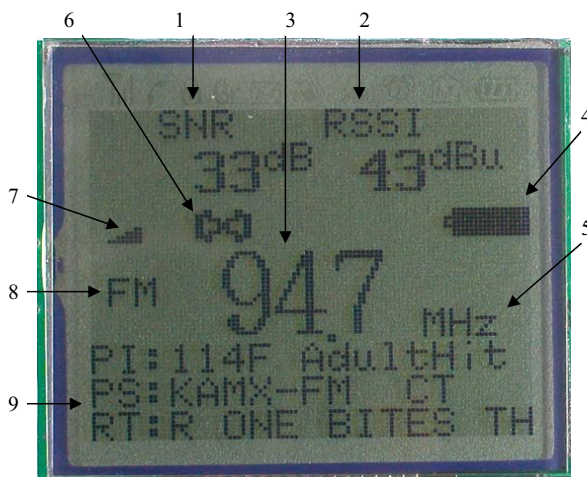

Figure 3. LCD Display in FM Radio Mode

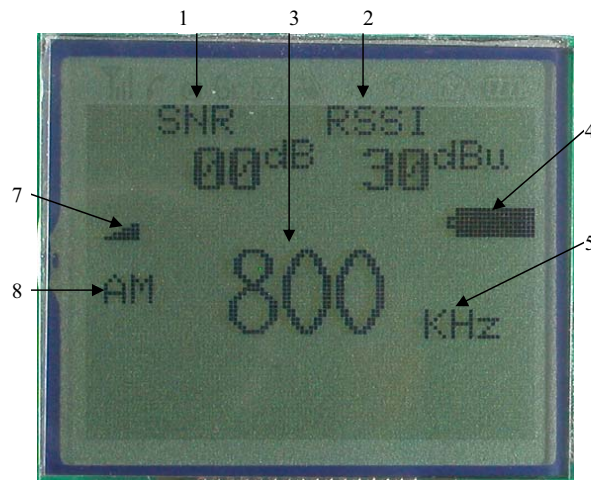

Figure 4. LCD Display in AM Radio Mode

4.2.1. Band Selection

In Radio Mode, the BANDS/0 key is used to switch between the AM and FM bands.

4.2.2. Time/Date Auto Set

Many radio stations broadcast RDS data including clock/time CT information. The AM/FM demo board can capture this information to automatically set the time and date. In FM Mode, when RDS CT information is received, the CT indicator will be displayed. The MEM/AL/1 button can be used to update the calendar date and time with the CT information. CT information is not available on all radio stations and is normally sent only once per minute.

4.2.3. Alternative Frequency (AF) Switching

The AM/FM demo board monitors RDS for alternate frequency (AF) information. When RDS alternative frequency information is received, the AF indicator will be displayed. If the signal quality of the currently tuned station degrades, the radio will automatically change to one of the alternative frequency stations.

4.2.4. Tune/Seek

In Radio Mode, pressing the UP/4 or DOWN/8 button for less than 0.5 s will tune the frequency by the preset step size. Holding the button for longer than 0.5 s but less than 3 s will perform a station seek.

4.2.5. Scan

In Radio Mode, the MSCAN/5 button is used to scan for all valid stations in the selected band and will automatically save them into preset selections. After a scan operation, the M+/3 and M-/7 keys will cycle through the preset station list. Scan operation can be aborted by pressing MSCAN/5 again, or by pressing the UP/4 or DOWN/8 key.

4.2.6. Parameter Settings

In Radio Mode, the SET/9 key is used to select the parameter setup menu as illustrated in Figure 5 and Figure 6. The M+/3 or M-/7 keys will cycle through the available items in the menu. The UP/4 or DOWN/8 keys are used to set the desired value for each item. Select "Yes" under "Factory Def" to go back to the factory default settings for all items.

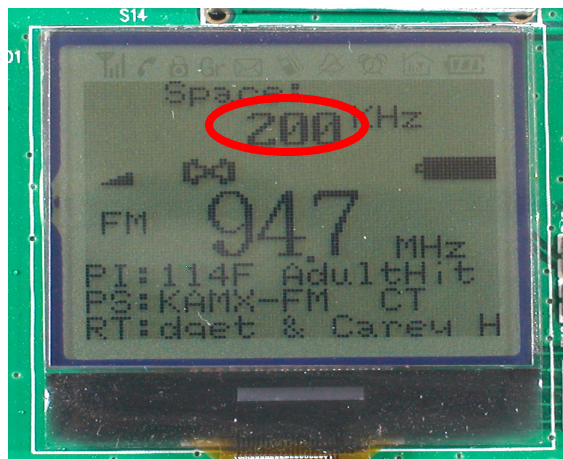

Figure 5. LCD Display in FM Setup Menu

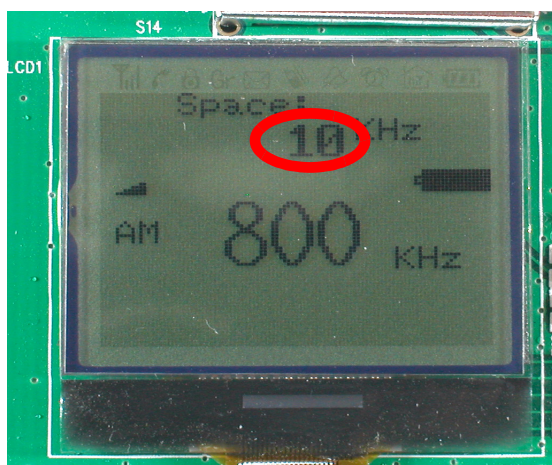

Figure 6. LCD Display in AM Setup Menu

4.2.7. Digit Keys

In Radio Mode, the FUNC/DIGIT key is used to switch the keypad to digital input mode. A “Dig” indicator is displayed in this mode and all keys marked with a digit are used to input a channel frequency. A frequency is considered valid if it lies within the band limits. If a non-valid frequency is entered, the closest band limit will be entered and displayed.

4.2.8. Volume

The VOL+/2 or VOL-/6 keys are used to adjust the volume up or down. The board audio output will be muted when volume is at the lowest setting.

4.2.9. AM Channel Spacing Auto Set

In AM Mode, the MEM/AL/1 key will automatically detect and set the channel spacing to either 9 or 10 kHz. The detection criterion determines which channel spacing results in more valid stations during a band scan. The number for the detection threshold is adjustable as described in Table 2. This operation can be aborted by pressing the MEM/AL/1 key again.

5. Human interface

There are 12 keys for controlling the demo board as shown in Figure 7:

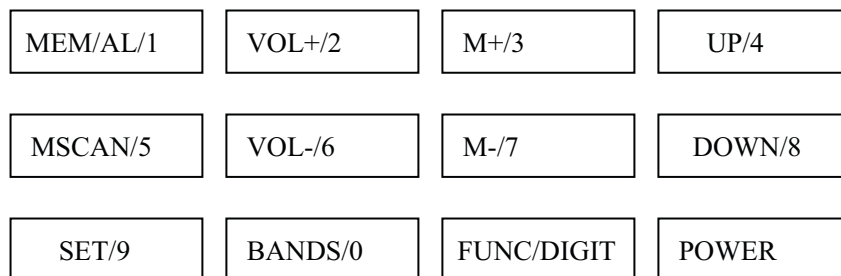

Figure 7. Human Interface Keys

Each key can have a different function under each operating condition:

- **Calendar/Powerdown Mode:** Radio function is disabled. LCD displays Calendar. Buttons can be used to set time, etc.
- **Radio AM/FM Mode:** Tuner IC works in powerup mode (FM or AM). Radio function is enabled. LCD displays the radio station parameters. Buttons are used to adjust radio settings.
- **Digital Input Mode:** Tuner IC works in powerup mode (FM or AM). Radio function is enabled. LCD displays the radio station parameters. The buttons are used for direct digit input of station frequencies.

The functions of the buttons are summarized in Table 1:

Table 1. Key Function Description

Button/Mode		Calendar Mode Tuner Off	Radio AM/FM Mode Tuner On
MEM/AL/1		None	FM Mode: Used to adjust calendar using received RDS CT. AM Mode: Used to automatically detect and set the channel spacing.
POWER		Enable radio	Disable radio function and enter calendar mode. (Radio parameters will be saved to Flash).
SET		Enter calendar setup menu	Enter radio setup menu. (Parameter list in Table 2)
BANDS		None	Change between FM and AM band.
UP/ DOWN	Hold Time < 0.5 s	In setup menu, change the current calendar item by one step.	In setup menu, change the current parameter by one step. In radio mode, tune up or down by one step.
	0.5 s < Hold Time < 3 s		Perform a station seek.
	Hold Time > 3 s	Fast parameter setting	Fast parameter setting.
MSCAN		None	Scan for all valid stations and save them to presets.

Note: Combination keying is entered and exited from Radio Mode by pressing and holding the SET key then pressing the BANDS key. A combination of the SET and the MSCAN keys will cycle through the available display items.

Si4731-DEMO

Table 1. Key Function Description (Continued)

Button/Mode	Calendar Mode Tuner Off	Radio AM/FM Mode Tuner On
M+ / M-	In setup menu, select next calendar item.	In setup menu, select next adjustable item. In radio mode, tune to the next preset station.
Vol+ / Vol-	None	< 3 s Increase or decrease volume 1 step.
		> 3 s Quickly increase or decrease volume.
FUNC/DIGIT	None	Shift the keyboard between normal function and digital input mode.
Combination keying	None	A: Radio IC version B: Firmware version C: Varactor reading D: AGC status
Note: Combination keying is entered and exited from Radio Mode by pressing and holding the SET key then pressing the BANDS key. A combination of the SET and the MSCAN keys will cycle through the available display items.		

The FM and AM radio parameters which can be configured from setup menu are listed below in Table 2.

Table 2. Radio Configuration Parameters

FM Parameter	AM Parameter
Spacing: 50/100/200 kHz Default: 100 kHz	Spacing: 1/9/10 kHz Default: 9 kHz
RSSI Seek: 0–127 dBμV Default: 20 dBμV	RSSI Seek: (0–63 dBμV Default: 25 dBμV
SNR Seek: 0–127 dB Default: 03 dB	SNR Seek: 0–63 dB Default: 05 dB
Pre-emphasis: 50 or 75 μs Default: 75 μs	Pre-emphasis: 00 disable, 50 μs Default: 00
Band High Threshold: Max 108 MHz Default: 107.90 MHz	Band High Threshold: Max 1710 kHz Default: 1710 kHz
Band Low Threshold: min 76 MHz Default: 87.50 MHz	Band Low Threshold: min 520 kHz Default: 522 kHz
Channel Filter: 00/40/60/80/100 kHz Default: 00 (Auto)	Channel Filter: 1/2/3/4/6 kHz Default: 2 kHz
RClock: 0: AFC disable 32763~32773 Default: 32768	RClock: 0 AFC disable 32763~32773 Default: 32768
Smute Rate: 0–255 Default: 64	Smute Rate: 0–255 Default: 64
Smute SNR: 0–15 dB Default: 4 dB	Smute SNR: 0–63 dB Default: 10 dB
Smute Attenuation: (0–31 dB) Default: 16 dB	Smute Attenuation: 0–63 dB Default: 16 dB

Table 2. Radio Configuration Parameters (Continued)

Blend Mono: 0–127 dB μ V Default: 30 dB μ V	Smute Slop: 1–5 Default: 2
Blend Stereo: 0–127 dBuV Default: 49dBuV	Set Factory Default: on/off Default:off
AGC Override: on/off Default: off	AM Channel Spacing Detection Threshold: 1,2,3,4,5,6 Default = 2
AGC Index: 0–26 Default : 0	
Set Factory Default: on/off Default:off	
RDS/RBDS Default: RBDS	

Si4731-DEMO

6. Bill of Materials

- C8051F930 MCU with 64 kB Flash program memory, 4 kB RAM, and built-in dc-dc converter
- AM/FM receiver IC Si4731 with external 32768 Hz crystal oscillator support
- ST7588T LCD driver IC
- LM4910 Audio amplifier IC
- See Table 3 for details.

Table 3. Si4731 Demo Board Bill of Materials

Item	Qty	Reference	Description	Value
1	3	C1, C16, C29	CAP,SM,0603,X7R	0.47 μ F
2	2	C4, C13	CAP,SM,0603,X7R	4.7 μ F
3	8	C15, C23-28, C41	CAP,SM,0603,X7R	1 μ F
4	6	C10, C14, C19, C37, C39-40	CAP,SM,0603,X7R	0.1 μ F
5	4	C2, C3, C21-22	CAP,SM,0603,X7R	22 pF
6	2	C8, C12	CAP,SM,0603,X7R	220 pF
7	2	C11, C18	CAP,SM,0603,X7R	820 pF
8	3	C5-7	CAP,SM,0603,X7R	100 pF
9	4	C17, C38, C44, C46	CAP,SM,0603,X7R	1 nF
10	8	C32-36, C54-C55, C43	CAP,SM,0603,X7R	NP
11	3	C30, C45, C53	RES,SM,0603	0R
12	1	C9	CAP,SM,1210,tantalum	100 μ F/6.3 V
13	1	C31	CAP,SM,1210,tantalum	220 μ F/4 V
14	4	R1-2, R3, R25	RES,SM,0603	0R
15	11	R7, R27, R29-32, R34, R36-39	RES,SM,0603	10 kW
16	2	R5, R11	RES,SM,0603	12 kW
17	4	R20, R22-23, R28	RES,SM,0603	1 kW
18	2	R4, R6	RES,SM,0603	5k6
19	2	R8, R10	RES,SM,0603	6k8
20	3	R9, R16-17	RES,SM,0603	2 kW
21	2	R18-19	RES,SM,0603	100R
22	5	R15, R21, R24, R26, R35	RES,SM,0603	NP
23	1	R12	RES,SM,0603	4k7
24	3	R13-14, R33	RES,SM,0603	100k
25	4	B1-4	FERRITE BEAD,SM,0805	2k5/100M
26	1	L1	IND,SM,0603	120 nH
27	1	L2	IND,SM,0603	270 nH
28	2	L3-4	RES,SM,0603	0R
29	1	U1	Si47xx, MLP20-3MM	Si47xx

Table 3. Si4731 Demo Board Bill of Materials (Continued)

30	1	U2	LM4910,SOP8	LM4910MA
31	1	U4	REGULATOR,SOT23	XC62FP3002MR
32	1	U3	C8051F920/30-GQ,LQFP32	C8051F920/30-GQ
33	1	D1	DIODE,SM,ESD,SOT23	BAV99
34	2	D2-4	DIODE,SM,ESD,SOT23	CM1214-01ST/SO
35	1	Q1	TRANSISTOR NPN SOT23	2N3904
36	1	T1	MW AIR LOOP ANTENNA TRANS-FORMER	SLMWTF01
37	1	J5	CONN,TH,2X10,HDR	
38	1	J4	Wire holder	
39	2	Y1-2	Crystal	32.768 kHz
40	2	J14-15	Stereo earphone jack	3.5 mm
41	2	JP3-4	CONN,TH,1X2,HDR	CONN,TH,1X2,HDR
42	2	JP1-2	CONN,TH,1X4,HDR	CONN,TH,1X4,HDR
43	4	J10-13	CONN,TH,1X5,HDR	CONN,TH,1X5,HDR
44	1	J1	BNC_VERTICAL	BNC for whip
45	2	J2-3	SMA_VERTICAL	SMA for FM/AM
46	1	S14	SLIDE SWITCH With 3 Double Pole Double Throw Switches inside	
47	1	S15	Single Pole Double Throw Switch	
48	13	S1-13	Button Switch	
49	1	LCD1	LCD	101*79 dots
50	1	ANT2	MW ferrite antenna	220 μ H
51	1	ANT3	MW loop antenna	10-20 μ H
52	1	BAT2	Battery BOX ,AAA*3 SIZE	
53	1	BAT1	Battery BOX ,AA SIZE	
DC-DC Power Block Circuit Part List				
54	1	L5	IND,SM,1008	0.68 μ H
55	1	C42	CAP,SM,0603,X7R	4.7 μ F

Si4731-DEMO

7. Schematics

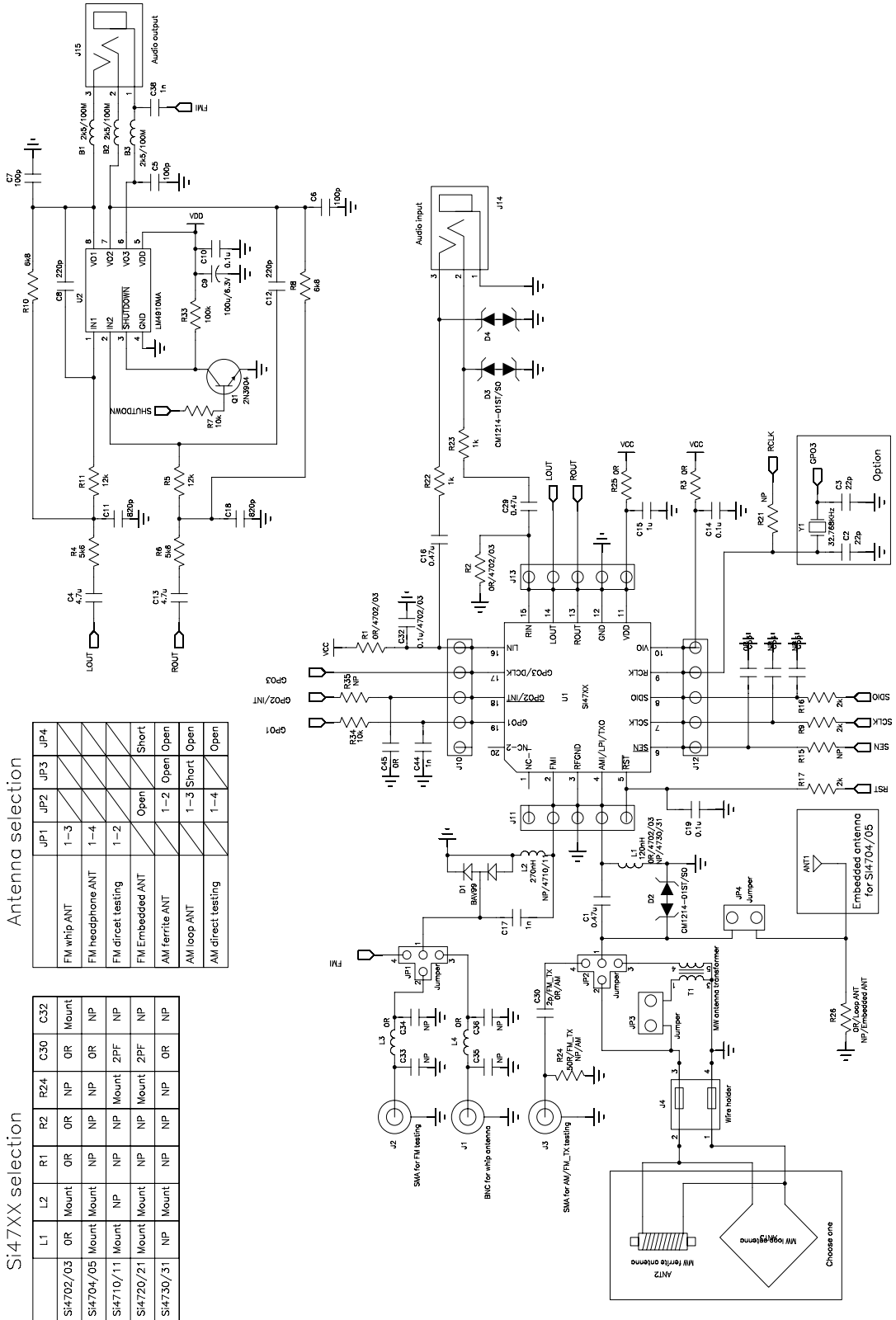

Antenna selection

	JP1	JP2	JP3	JP4
FM whip ANT	1-3			
FM headphone ANT	1-4			
FM direct testing	1-2			Short
FM Embedded ANT		Open		Open
AM ferrite ANT		1-2	Open	Open
AM loop ANT		1-3	Short	Open
AM direct testing		1-4		Open

Si47XX selection

	L1	L2	R1	R2	R24	C30	C32
Si4702/03	OR	Mount	OR	OR	NP	OR	Mount
Si4704/05	Mount	Mount	NP	NP	NP	OR	NP
Si4710/11	Mount	NP	NP	NP	Mount	2PF	NP
Si4720/21	Mount	Mount	NP	NP	Mount	2PF	NP
Si4730/31	NP	Mount	NP	NP	NP	OR	NP

Figure 8. Si4731-DEMO Board Schematic—Radio and Audio Portions

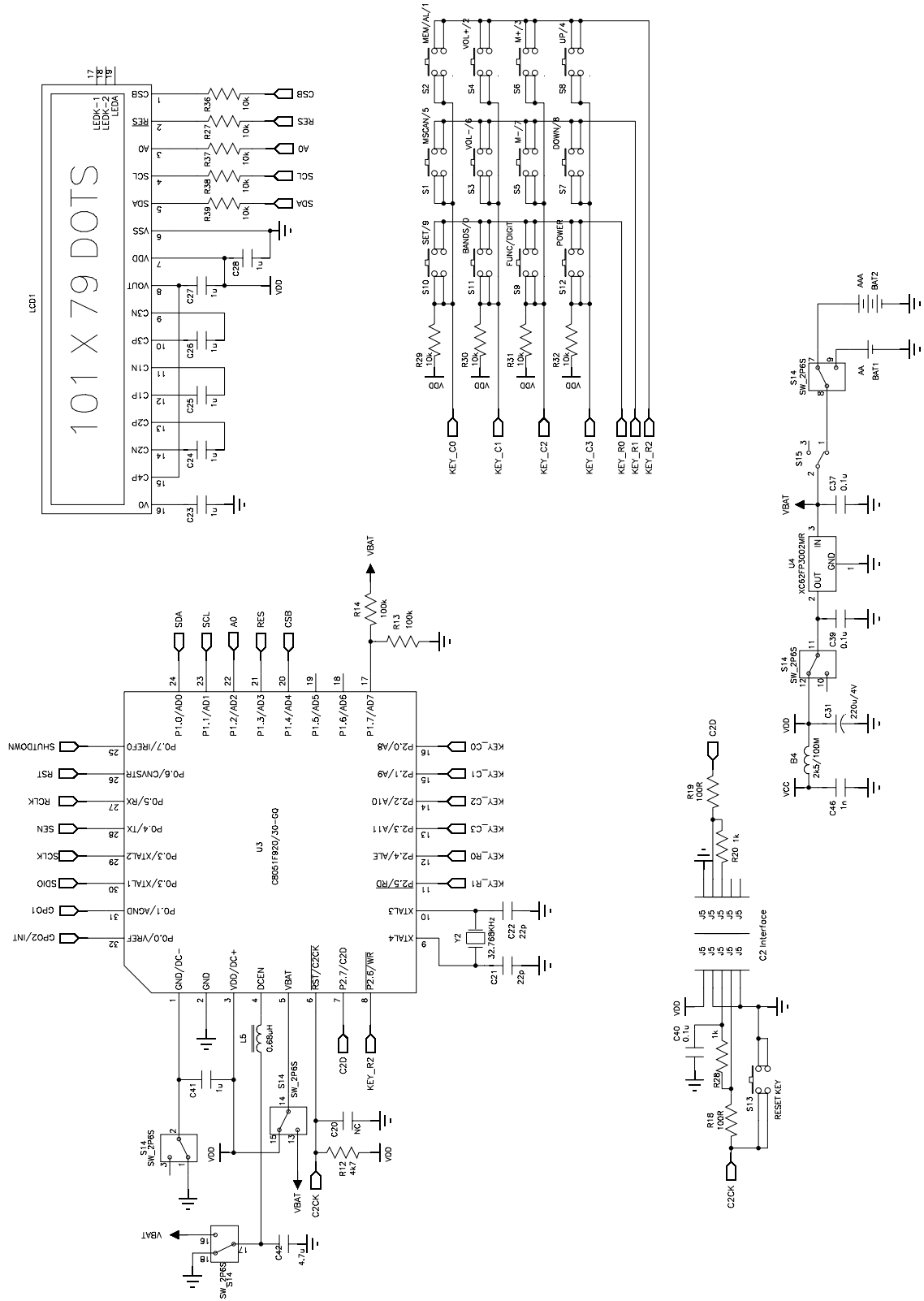

Figure 9. Si4731-DEMO Board Schematic—MCU Portion

Si4731-DEMO

CONTACT INFORMATION

Silicon Laboratories Inc.
400 West Cesar Chavez
Austin, TX 78701
Tel: 1+(512) 416-8500
Fax: 1+(512) 416-9669
Toll Free: 1+(877) 444-3032
Email: FMinfo@silabs.com
Internet: www.silabs.com

The information in this document is believed to be accurate in all respects at the time of publication but is subject to change without notice. Silicon Laboratories assumes no responsibility for errors and omissions, and disclaims responsibility for any consequences resulting from the use of information included herein. Additionally, Silicon Laboratories assumes no responsibility for the functioning of undescribed features or parameters. Silicon Laboratories reserves the right to make changes without further notice. Silicon Laboratories makes no warranty, representation or guarantee regarding the suitability of its products for any particular purpose, nor does Silicon Laboratories assume any liability arising out of the application or use of any product or circuit, and specifically disclaims any and all liability, including without limitation consequential or incidental damages. Silicon Laboratories products are not designed, intended, or authorized for use in applications intended to support or sustain life, or for any other application in which the failure of the Silicon Laboratories product could create a situation where personal injury or death may occur. Should Buyer purchase or use Silicon Laboratories products for any such unintended or unauthorized application, Buyer shall indemnify and hold Silicon Laboratories harmless against all claims and damages.

Silicon Laboratories and Silicon Labs are trademarks of Silicon Laboratories Inc.

Other products or brandnames mentioned herein are trademarks or registered trademarks of their respective holders.