

SI-3000KD Series Surface-Mount, Low Current Consumption, Low Dropout Voltage

Features

- Compact surface-mount package (TO263-5)
- Output current: 1.0A
- Low dropout voltage: $V_{DIF} \leq 0.6V$ (at $I_o = 1.0A$)
- Low circuit current consumption: $I_q \leq 350 \mu A$ (600 μA for SI-3010KD, SI-3050KD)
- Low circuit current at output OFF: $I_q (OFF) \leq 1 \mu A$
- Built-in overcurrent, thermal protection circuits
- Compatible with low ESR capacitors (SI-3012KD and SI-3033KD)

Absolute Maximum Ratings

(T_a=25°C)

Parameter	Symbol	Ratings		Unit
		SI-3012KD/3033KD	SI-3010KD/3050KD	
DC Input Voltage	V _{IN}	17	35 ^{*1}	V
DC Output Current	I _o	1.0		A
Power Dissipation	P _D ^{*2}	3		W
Junction Temperature	T _j	-30 to +125		°C
Storage Temperature	T _{stg}	-30 to +125		°C
Thermal Resistance (Junction to Ambient Air)	θ _{j-a}	33.3		°C/W
Thermal Resistance (Junction to Case)	θ _{j-c}	3		°C/W

*1: A built-in input-overvoltage-protection circuit shuts down the output voltage at the Input Overvoltage Shutdown Voltage of the electrical characteristics.

*2: When mounted on glass-epoxy board of 1600mm² (copper laminate area 100%).

Applications

- Secondary stabilized power supply (local power supply)

Electrical Characteristics 1 (Low Input Voltage type compatible with low ESR output capacitor) (T_a=25°C, V_C=2V, unless otherwise specified)

Parameter	Symbol	Ratings						Unit
		SI-3012KD (Variable type)			SI-3033KD			
		min.	typ.	max.	min.	typ.	max.	
Input Voltage	V _{IN}	2.4 ^{*3}		*4	*3		*4	V
Output Voltage (Reference Voltage for SI-3012KD)	V _O (V _{ADJ})	1.24	1.28	1.32	3.234	3.300	3.366	V
Line Regulation	ΔV _{OLINE}	V _{IN} =3.3V, I _o =10mA			V _{IN} =5V, I _o =10mA			mV
	Conditions	V _{IN} =3.3 to 8V, I _o =10mA (V _O =2.5V)			V _{IN} =5 to 10V, I _o =10mA			
Load Regulation	ΔV _{OLOAD}				15			mV
	Conditions	V _{IN} =3.3V, I _o =0 to 1A (V _O =2.5V)			V _{IN} =5V, I _o =0 to 1A			
Dropout Voltage	V _{DIF}	0.4			0.4			V
	Conditions	I _o =0.5A (V _O =2.5V)			I _o =0.5A			
	Conditions	I _o =1A (V _O =2.5V)			I _o =1A			
Quiescent Circuit Current	I _q	350			350			μA
	Conditions	V _{IN} =3.3V, I _o =0A, V _C =2V, R ₂ =2.4kΩ			V _{IN} =5V, I _o =0A, V _C =2V			
Circuit Current at Output OFF	I _q (OFF)	1			1			μA
	Conditions	V _{IN} =3.3V, V _C =0V			V _{IN} =5V, V _C =0V			
Temperature Coefficient of Output Voltage	ΔV _O /ΔT _a	±0.3			±0.3			mV/°C
	Conditions	T _j =0 to 100°C (V _O =2.5V)			T _j =0 to 100°C			
Ripple Rejection	R _{REJ}	55			55			dB
	Conditions	V _{IN} =3.3V, f=100 to 120Hz, I _o =0.1A (V _O =2.5V)			V _{IN} =5V, f=100 to 120Hz, I _o =0.1A			
Overcurrent Protection Starting Current ^{*1}	I _{S1}	1.1			1.1			A
	Conditions	V _{IN} =3.3V			V _{IN} =5V			
V _C Terminal	Control Voltage (Output ON) ^{*2}	2			2			V
	Control Voltage (Output OFF)			0.8			0.8	V
	Control Current (Output ON)			40			40	μA
	Conditions	V _C =2V			V _C =2V			
Control Current (Output OFF)	I _C , I _L	-5	0		-5	0		μA
	Conditions	V _C =0V			V _C =0V			

*1: I_{S1} is specified at the 5% drop point of output voltage V_O under the condition of Output Voltage parameter.

*2: Output is OFF when the output control terminal (V_C terminal) is open. Each input level is equivalent to LS-TTL level. Therefore, the device can be driven directly by LS-TTLs.

*3: Refer to the Dropout Voltage parameter.

*4: V_{IN} (max) and I_o (max) are restricted by the relation P_D = (V_{IN} - V_O) × I_o. Please calculate these values referring to the Copper laminate area vs. Power dissipation data.

Electrical Characteristics 2 (High Input Voltage Type)

Parameter	Symbol	Ratings						Unit
		SI-3010KD (Variable type)			SI-3050KD			
		min.	typ.	max.	min.	typ.	max.	
Input Voltage	V _{IN}	2.4 ^{*1}		27 ^{*5}	^{*1}			V
Output Voltage (Reference Voltage V _{ADJ} for SI-3010KD)	V _O (V _{ADJ})	0.98	1.00	1.02	4.90	5.00	5.10	V
	Conditions	V _{IN} =7V, I _O =10mA			V _{IN} =7V, I _O =10mA			
Line Regulation	ΔV _{OLINE}			30			30	mV
	Conditions	V _{IN} =6 to 11V, I _O =10mA (V _O =5V)			V _{IN} =6 to 11V, I _O =10mA			
Load Regulation	ΔV _{OLOAD}			75			75	mV
	Conditions	V _{IN} =7V, I _O =0 to 1A (V _O =5V)			V _{IN} =7V, I _O =0 to 1A			
Dropout Voltage	V _{DIF}			0.3			0.3	V
	Conditions	I _O =0.5A (V _O =5V)			I _O =0.5A			
	Conditions	I _O =1A (V _O =5V)			I _O =1A			
Quiescent Circuit Current	I _q			600			600	μA
	Conditions	V _{IN} =7V, I _O =0A, V _C =2V R ₂ =10kΩ			V _{IN} =7V, I _O =0A, V _C =2V			
Circuit Current at Output OFF	I _q (OFF)			1			1	μA
	Conditions	V _{IN} =7V, V _C =0V			V _{IN} =7V, V _C =0V			
Temperature Coefficient of Output Voltage	ΔV _O /ΔT _a		±0.5			±0.5		mV/°C
	Conditions	T _j =0 to 100°C (V _O =5V)			T _j =0 to 100°C			
Ripple Rejection	R _{REJ}		75			75		dB
	Conditions	V _{IN} =7V, f=100 to 120Hz, I _O =0.1A (V _O =5V)			V _{IN} =7V, f=100 to 120Hz, I _O =0.1A			
Overcurrent Protection Starting Current ^{*2}	I _{S1}	1.1			1.1			A
	Conditions	V _{IN} =7V			V _{IN} =7V			
V _C Terminal	Control Voltage (Output ON) ^{*3}	V _C , IH	2.0		2.0			V
	Control Voltage (Output OFF) ^{*3}	V _C , IL					0.8	V
	Control Current (Output ON)	I _C , IH			40		40	μA
	Control Current (Output OFF)	I _C , IL	-5	0		-5	0	μA
		Conditions	V _C =2V			V _C =2V		
	Conditions	V _C =0V			V _C =0V			
Input Overvoltage Shutdown Voltage	V _{OVP}	33			26			V
	Conditions	I _O =10mA			I _O =10mA			

*1: Refer to the Dropout Voltage parameter.

*2: I_{S1} is specified at the 5% drop point of output voltage V_O under the condition of Output Voltage parameter.

*3: Output is OFF when the output control terminal (V_C terminal) is open. Each input level is equivalent to LS-TTL level. Therefore, the device can be driven directly by LS-TTLs.

*4: SI-3010KD, SI-3050KD, cannot be used in the following applications because the built-in foldback-type overcurrent protection may cause errors during start-up stage.

(1) Constant current load (2) Positive and negative power supply (3) Series-connected power supply (4) V_O adjustment by raising ground voltage

*5: V_{IN} (max) and I_O (max) are restricted by the relation P_D = (V_{IN} - V_O) × I_O. Please calculate these values referring to the Copper laminate area vs. Power dissipation data as shown hereinafter.

External Dimensions (TO263-5)

(unit : mm)

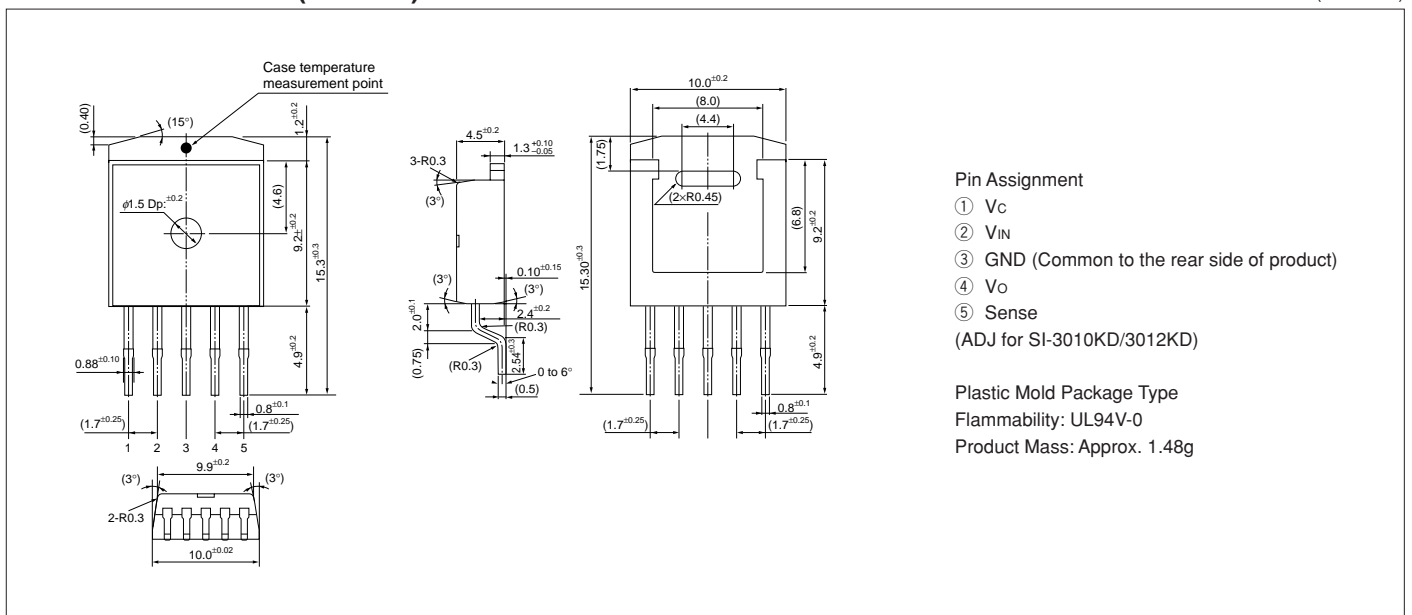

■Block Diagram

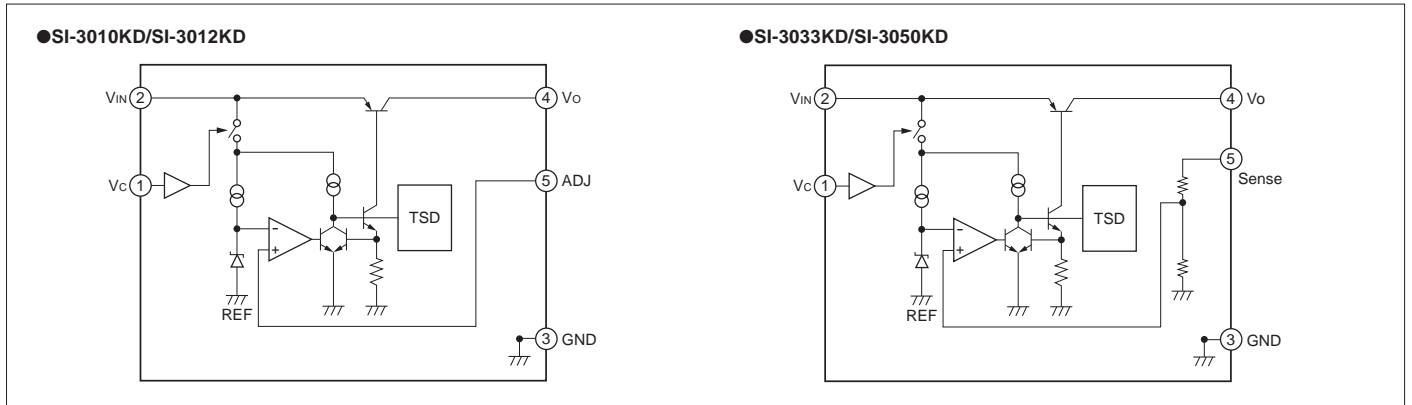

■Typical Connection Diagram

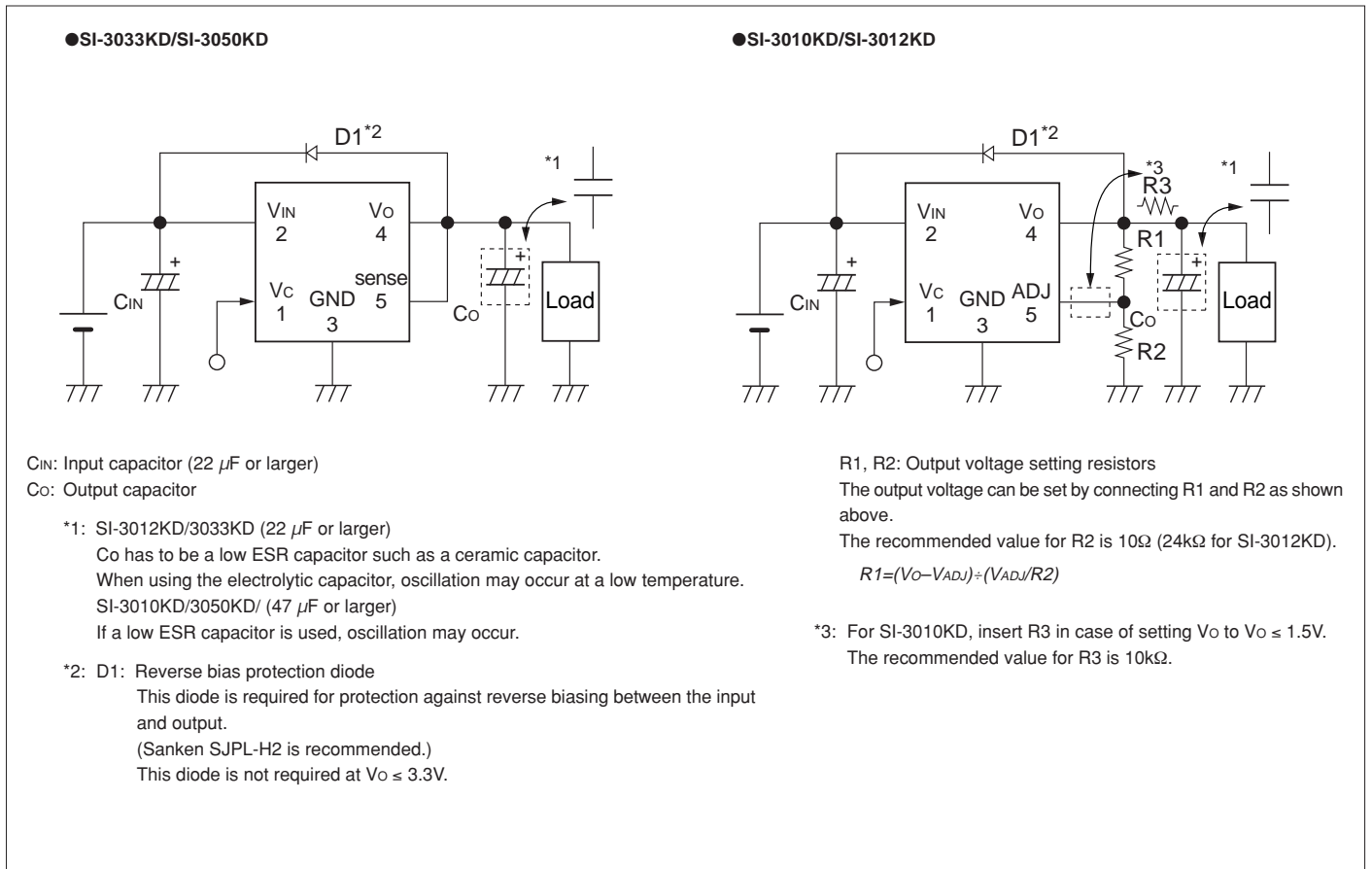

■Reference Data

