

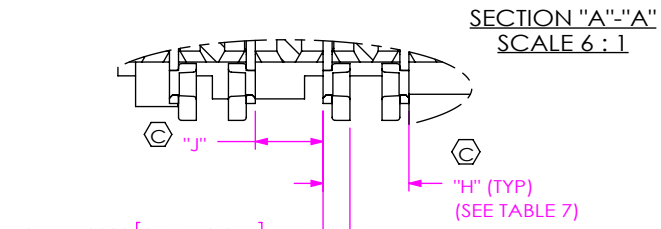

NEW-SUB-C-209-XX.X-X-X

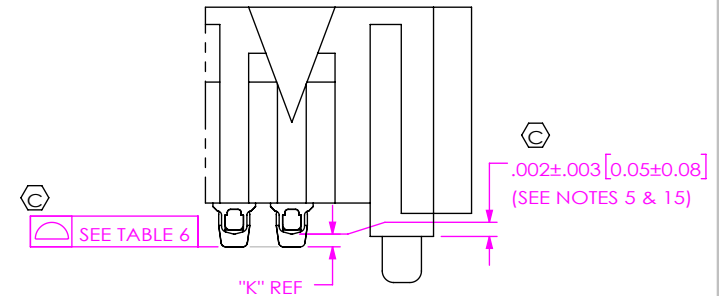
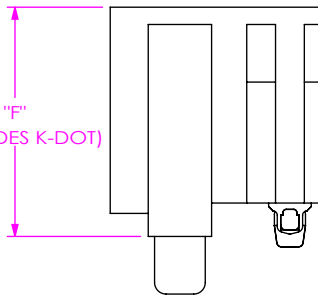
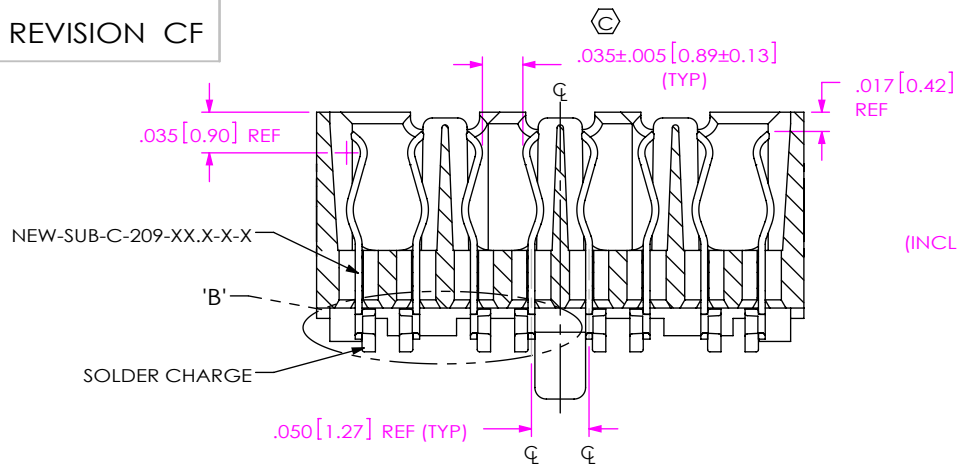
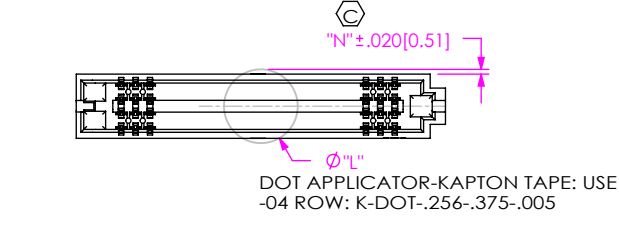
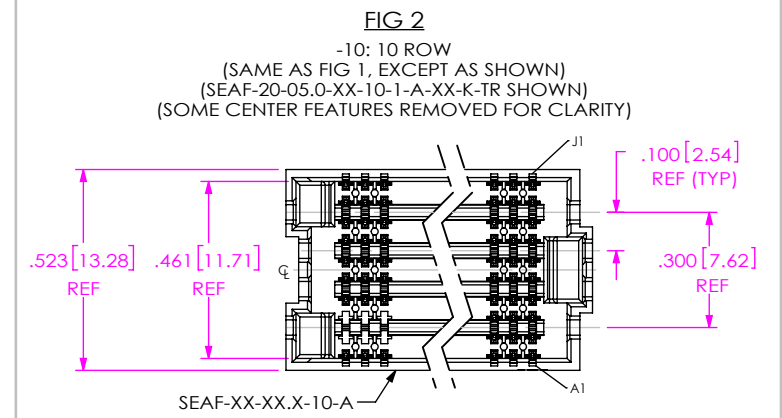

**TABLE 6**

POSITION	COPLANARITY
-10 TO -30	.006 [0.15]
-40	.009 [0.23]
-50	.009 [0.23]

**TABLE 7**

LEAD STYLE	"H"	"J"	"K"
-05.0	.0530 - .0590 [1.346] - [1.499]	.0410 - .0470 [1.041] - [1.194]	.011 [0.28]
-06.0	.0530 - .0620 [1.346] - [1.575]	.0380 - .0470 [.965] - [1.194]	.011 [0.28]
-06.5	.0530 - .0645 [1.346] - [1.638]	.0355 - .0470 [.902] - [1.194]	.011 [0.28]
-07.5	.0530 - .0645 [1.346] - [1.638]	.0355 - .0470 [.902] - [1.194]	.011 [0.28]



**TABLE 8**

ROWS	"M"										"N"
	"L"	10 POS	15 POS	19 POS	20 POS	25 POS	30 POS	40 POS	50 POS	"N"	
-04	.256 [6.50]	.254 [6.44]	.379 [9.62]	.479 [12.16]	.504 [12.79]	.629 [15.97]	.754 [19.14]	1.004 [25.49]	1.254 [31.84]	.017 [.43]	
-05, -06	.256 [6.50]	.254 [6.44]	.379 [9.62]	.479 [12.16]	.504 [12.79]	.629 [15.97]	.754 [19.14]	1.004 [25.49]	1.254 [31.84]	.034 [.86]	
-08	.325 [8.25]	.219 [5.57]	.344 [8.74]	.444 [11.28]	.469 [11.92]	.594 [15.09]	.719 [18.27]	.969 [24.62]	1.219 [30.97]	.049 [1.24]	
-10	.404 [10.25]	.180 [4.57]	.305 [7.74]	.405 [10.28]	.430 [10.92]	.555 [14.09]	.680 [17.27]	.930 [23.62]	1.180 [29.97]	.060 [1.52]	
-14	.404 [10.25]	N/A	N/A	N/A	N/A	N/A	N/A	.930 [23.62]	N/A	.160 [4.05]	

-04 ROW ONLY  
(SAME AS FIG 3, EXCEPT AS SHOWN)

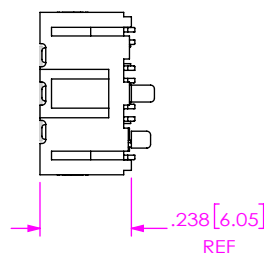
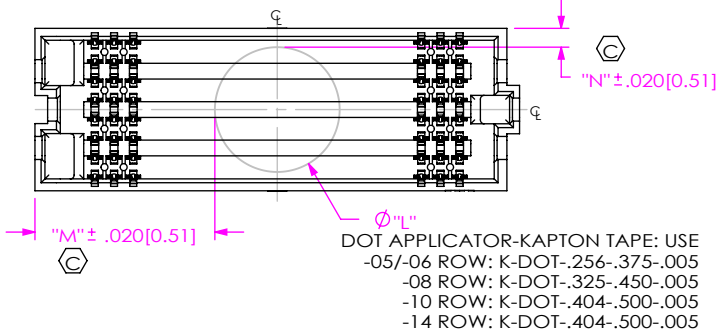

**FIG 3**  
-K: POLYIMIDE PAD  
(SEAF-20-06.0-XX-08-1-A-XX-K-TR SHOWN)  
(SAME AS FIG. 1, EXCEPT AS SHOWN)  
(SOME CENTER FEATURES REMOVED FOR CLARITY)

**PROPRIETARY NOTE**  
THIS DOCUMENT CONTAINS CONFIDENTIAL AND PROPRIETARY INFORMATION AND ALL DESIGN, MANUFACTURING, REPRODUCTION, USE, PATENT RIGHTS AND SALES RIGHTS ARE EXPRESSLY RESERVED BY SAMTEC, INC. THIS DOCUMENT SHALL NOT BE DISCLOSED, IN WHOLE OR PART, TO ANY UNAUTHORIZED PERSON OR ENTITY NOR REPRODUCED, TRANSFERRED OR INCORPORATED IN ANY OTHER PROJECT IN ANY MANNER WITHOUT THE EXPRESS WRITTEN CONSENT OF SAMTEC, INC.

DO NOT SCALE DRAWING  
SHEET SCALE: 2:1

**samtec**  
520 PARK EAST BLVD, NEW ALBANY, IN 47150  
PHONE: 812-944-6733 FAX: 812-948-5047  
e-Mail info@SAMTEC.com code 55322

DESCRIPTION:  
.050 PITCH SOCKET ARRAY ASSEMBLY  
DWG. NO.  
**SEAF-XX-XX.X-XX-XX-X-A-XX-K-XR**  
BY: BRATCHER 05/27/2004 SHEET 2 OF 5

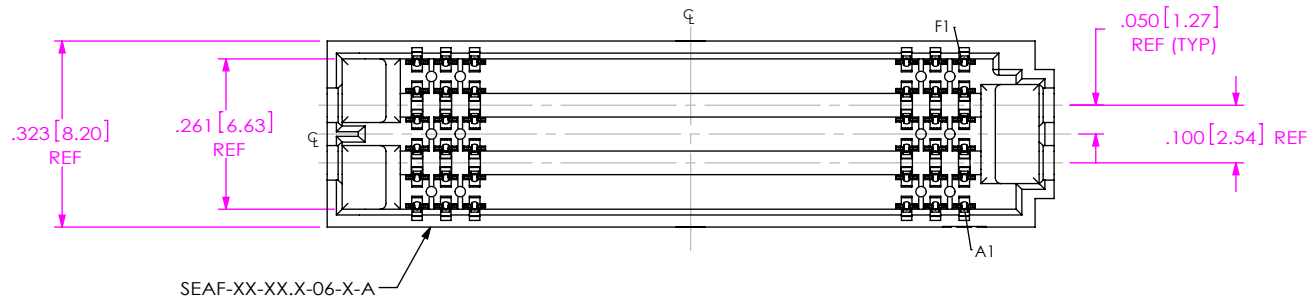

**FIG 4**  
 -06: 6 ROW  
 (SAME AS FIG 1, EXCEPT AS SHOWN)  
 (SEAF-20-05.0-XX-06-1-A-XX-K-TR SHOWN)  
 (SOME CENTER FEATURES REMOVED FOR CLARITY)

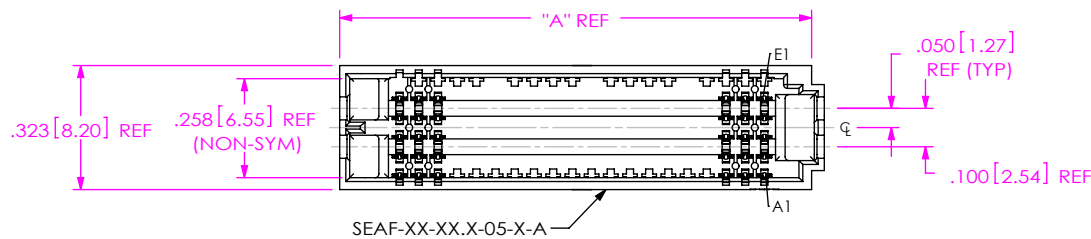

SEAF-XX-XX.X-05-X-A

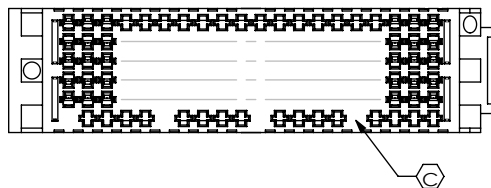
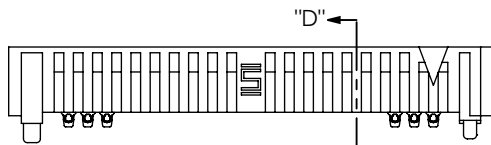

**FIG 5**  
 -05: 5 ROW  
 (SAME AS FIG 4, EXCEPT AS SHOWN)  
 (SEAF-20-05.0-XX-05-1-A-XX-K-TR SHOWN)  
 (SOME CENTER FEATURES REMOVED FOR CLARITY)

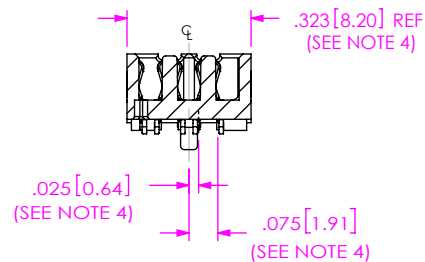

SECTION "D"-"D"

**PROPRIETARY NOTE**  
 THIS DOCUMENT CONTAINS CONFIDENTIAL AND PROPRIETARY INFORMATION AND ALL DESIGN, MANUFACTURING, REPRODUCTION, USE, PATENT RIGHTS AND SALES RIGHTS ARE EXPRESSLY RESERVED BY SAMTEC, INC. THIS DOCUMENT SHALL NOT BE DISCLOSED, IN WHOLE OR PART, TO ANY UNAUTHORIZED PERSON OR ENTITY NOR REPRODUCED, TRANSFERRED OR INCORPORATED IN ANY OTHER PROJECT IN ANY MANNER WITHOUT THE EXPRESS WRITTEN CONSENT OF SAMTEC, INC.

DO NOT SCALE DRAWING

SHEET SCALE: 1:0.333333



520 PARK EAST BLVD, NEW ALBANY, IN 47150  
 PHONE: 812-944-6733 FAX: 812-948-5047  
 e-Mail info@SAMTEC.com code 55322

DESCRIPTION:  
 .050 PITCH SOCKET ARRAY ASSEMBLY  
 DWG. NO.  
**SEAF-XX-XX.X-XX-XX-X-A-XX-K-XR**

BY: BRATCHER 05/27/2004 SHEET 3 OF 5

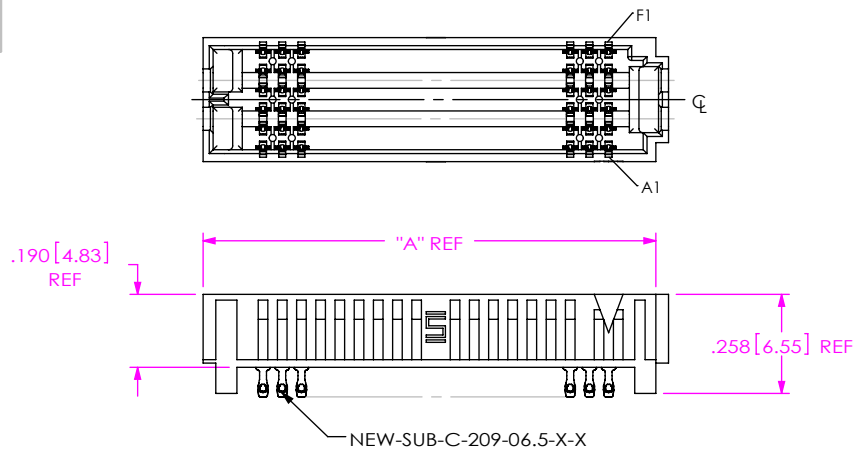

**FIG 7**  
06 ROW x 19 POS  
(ONLY AVAILABLE -06.5 LEADSTYLE & -06 ROW)  
(SEAF-20-06.5-XX-06-1-XX-K-TR SHOWN)  
(SAME AS FIGS 1 & 4 EXCEPT AS SHOWN)  
(SOME CENTER FEATURES REMOVED FOR CLARITY)

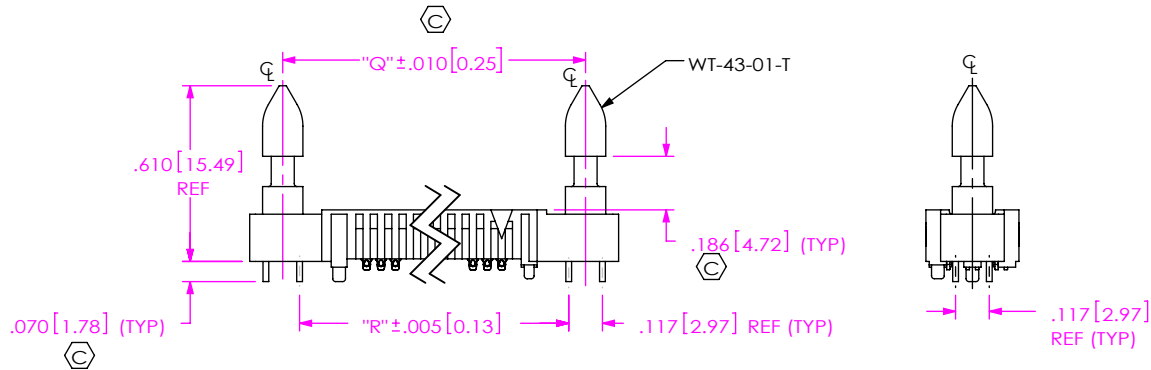
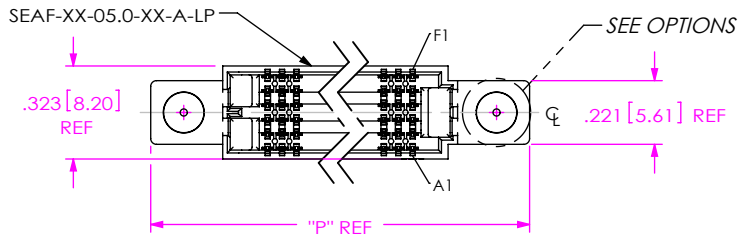

**FIG 8**  
-LP OPTION  
(SEAF-20-05.0-XX-06-1-A-LP-K-TR SHOWN)  
(SOME CENTER FEATURES REMOVED FOR CLARITY)  
(SAME AS FIG 1 EXCEPT AS SHOWN)  
(-LP OPTION REQUIRED FOR SEAC MATE ONLY)  
(ONLY AVAILABLE WITH -05.0 LEAD STYLE -04, -06, -08 & -10 ROW)

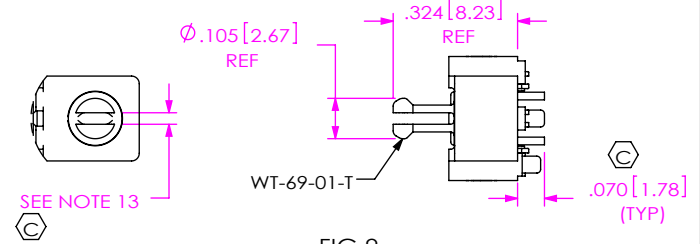

**FIG 9**  
-RP OPTION  
(SEAF-20-05.0-XX-06-1-A-RP-K-TR SHOWN)  
(SOME CENTER FEATURES REMOVED FOR CLARITY)  
(SAME AS FIG 7 EXCEPT AS SHOWN)  
(-RP OPTION VALID FOR SEAR MATE ONLY)  
(ONLY AVAILABLE WITH -05.0 LEAD STYLE 6, 8 & 10 ROW)

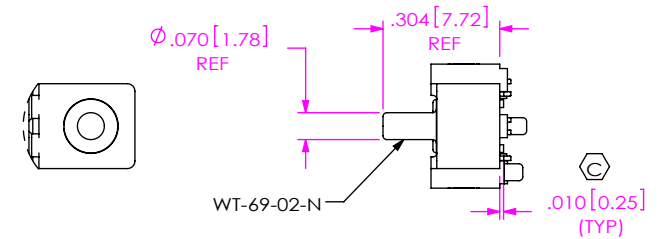

**FIG 10**  
-PP OPTION  
(SEAF-20-05.0-XX-06-1-A-PP-K-TR SHOWN)  
(SOME CENTER FEATURES REMOVED FOR CLARITY)  
(SAME AS FIG 8 EXCEPT AS SHOWN)  
(-PP OPTION VALID FOR SEAR MATE ONLY)  
(ONLY AVAILABLE WITH -05.0 LEAD STYLE 6, 8 & 10 ROW)

**TABLE 9**

No OF POS.	"P"	"Q"	"R"
-10	1.262 [32.05]	1.033 [26.24]	.9160 [23.266]
-15	1.512 [38.40]	1.283 [32.59]	1.1660 [29.616]
-19	1.712 [43.48]	1.483 [37.67]	1.3660 [34.696]
-20	1.762 [44.75]	1.533 [38.94]	1.4160 [35.966]
-25	2.012 [51.10]	1.783 [45.29]	1.6660 [42.316]
-30	2.262 [57.45]	2.033 [51.64]	1.9160 [48.666]
-40	2.762 [70.15]	2.533 [64.34]	2.4160 [61.366]
-50	3.262 [82.85]	3.033 [77.04]	2.9160 [74.066]

**PROPRIETARY NOTE**

THIS DOCUMENT CONTAINS CONFIDENTIAL AND PROPRIETARY INFORMATION AND ALL DESIGN, MANUFACTURING, REPRODUCTION, USE, PATENT RIGHTS AND SALES RIGHTS ARE EXPRESSLY RESERVED BY SAMTEC, INC. THIS DOCUMENT SHALL NOT BE DISCLOSED, IN WHOLE OR PART, TO ANY UNAUTHORIZED PERSON OR ENTITY NOR REPRODUCED, TRANSFERRED OR INCORPORATED IN ANY OTHER PROJECT IN ANY MANNER WITHOUT THE EXPRESS WRITTEN CONSENT OF SAMTEC, INC.

DO NOT SCALE DRAWING

SHEET SCALE: 1:0.333333



520 PARK EAST BLVD, NEW ALBANY, IN 47150  
PHONE: 812-944-6733 FAX: 812-948-5047  
e-Mail info@SAMTEC.com code 55322

DESCRIPTION:  
.050 PITCH SOCKET ARRAY ASSEMBLY

DWG. NO.  
**SEAF-XX-XX.X-XX-XX-X-A-XX-K-XR**

BY: BRATCHER 05/27/2004 SHEET 4 OF 5

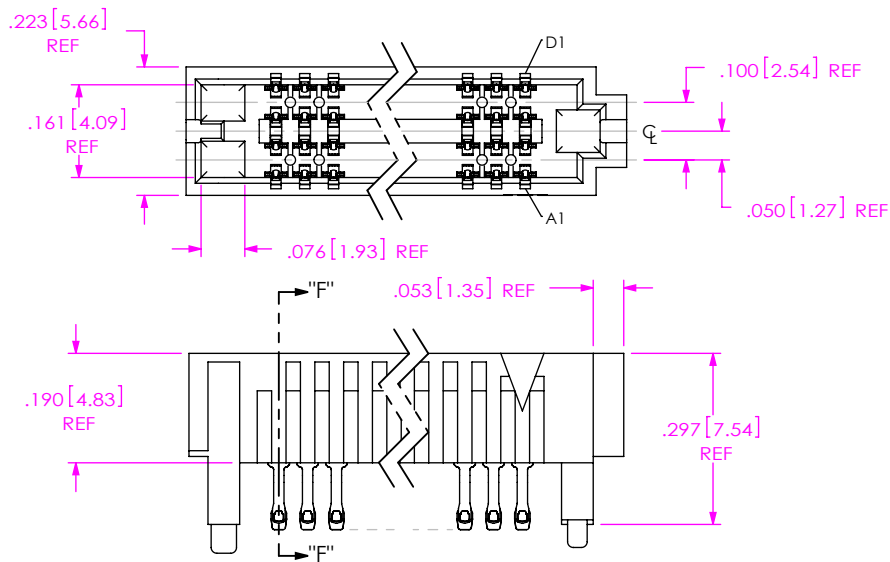

**FIG 11**  
 -04: 4 ROW  
 (SEAF-30-07.5-XX-04-1-A-XX-K-TR SHOWN)  
 (SOME CENTER FEATURES REMOVED FOR CLARITY)  
 (SAME AS FIG 1 EXCEPT AS SHOWN)

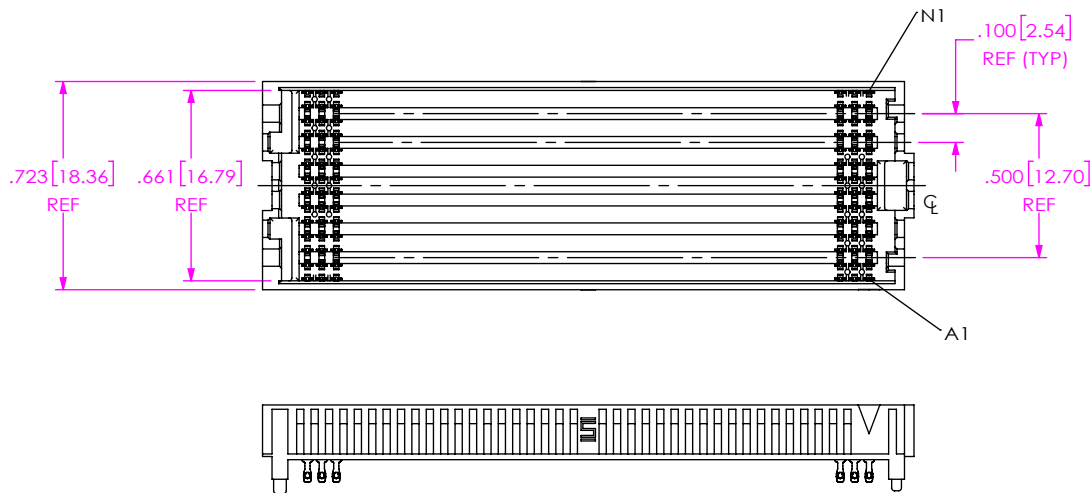

**FIG 12**  
 -14: 14 ROW  
 (SEAF-40-06.5-XX-14-1-A-XX-K-TR SHOWN)  
 (SOME CENTER FEATURES REMOVED FOR CLARITY)  
 (SAME AS FIG 1 EXCEPT AS SHOWN)

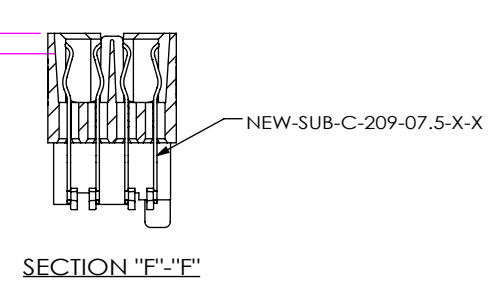

**SECTION "F"- "F"**

**PROPRIETARY NOTE**  
 THIS DOCUMENT CONTAINS CONFIDENTIAL AND PROPRIETARY INFORMATION AND ALL DESIGN, MANUFACTURING, REPRODUCTION, USE, PATENT RIGHTS AND SALES RIGHTS ARE EXPRESSLY RESERVED BY SAMTEC, INC. THIS DOCUMENT SHALL NOT BE DISCLOSED, IN WHOLE OR PART, TO ANY UNAUTHORIZED PERSON OR ENTITY NOR REPRODUCED, TRANSFERRED OR INCORPORATED IN ANY OTHER PROJECT IN ANY MANNER WITHOUT THE EXPRESS WRITTEN CONSENT OF SAMTEC, INC.

DO NOT SCALE DRAWING

SHEET SCALE: 1:0.333333



520 PARK EAST BLVD, NEW ALBANY, IN 47150  
 PHONE: 812-944-6733 FAX: 812-948-5047  
 e-Mail info@SAMTEC.com code 55322

DESCRIPTION:  
 .050 PITCH SOCKET ARRAY ASSEMBLY

DWG. NO.  
**SEAF-XX-XX.X-XX-XX-X-A-XX-K-XR**

BY: BRATCHER 05/27/2004 SHEET 5 OF 5