

2x20A or 1x40A High Performance Dual Channel Brushed DC Motor Controller with USB and CAN Interface



Fitting into a very compact 73x73mm enclosure, Roboteq's SDC21xx controller is designed to convert commands received from an RC radio, Analog Joystick, wireless modem, PC (via RS232 or USB) or microcomputer into high voltage and high current output for driving one or two DC motors. A CAN bus interface allows up to 127 controllers to communicate at up to 1Mbit/s on a single twisted pair.

The controller features a high-performance 32-bit microcomputer and quadrature encoder inputs to perform advanced motion control algorithms in Open Loop or Close Loop (Speed or Position) modes. The SDC21xx features several Analog, Pulse and Digital I/Os which can be remapped as command or feedback inputs, limit switches, or many other functions.

For mobile robotic applications, the controller's two motor channels can either be operated independently or mixed to set the direction and rotation of a vehicle by coordinating the motion of each motor. Numerous safety features are incorporated into the controller to ensure reliable and safe operation. The controller's operation can be extensively automated and customized by utilizing user generated Basic Language programs. The controller can be reprogrammed in the field with the latest features by downloading new operating software from Roboteq.

Applications

- Industrial Automation
- Tracking, Pan & Tilt systems
- Small to mid-size Terrestrial and Underwater Robotic Vehicles
- Automatic Guided Vehicles (AGV)
- Automated machines
- Telepresence Systems
- Animatronics

Features List

- USB, RS232, 0-5V Analog, or Pulse (RC radio) command modes
- CAN bus interface up to 1Mbit/s
- Auto switch between USB, RS232 (12V levels or non-inverted TTL levels), CAN, Analog, or Pulse based on user-defined priority
- Built-in, high-current power drivers for two brushed DC motors at up to 20A output per channel
- Available in single channel version up to 40A
- Full forward and reverse control on each channel. Four quadrant operation. Supports regeneration
- Built-in programming language for automation and customization
- Operates from a single power source
- Programmable current limit for each channel up to 2x20A or 1x40A for protecting controller, motors, wiring and battery
- Up to six Analog Inputs for use as command and/or feedback
- Up to six Pulse Length, Duty Cycle or Frequency Inputs for use as command and/or feedback
- Up to six Digital Inputs for use as Deadman Switch, Limit Switch, Emergency stop or user inputs
- Dual Quadrature Encoder inputs with 32-bit counters
- Two general purpose 24V, 1A output for brake release or accessories
- Selectable min/max, center and deadband in Pulse and Analog modes
- Selectable exponentiation factors for each command inputs
- Trigger action if Analog, Pulse or Encoder capture are outside user selectable range (soft limit switches)
- Open loop or closed loop speed control operation

- Closed loop position control with analog or pulse/frequency feedback
- Precise speed and position control when Encoder feedback is used
- PID control loop with separate gains for each channel
- Optional Mixed control (sum and difference) for tank-like steering
- Configurable Data Logging of operating parameters on RS232 Output for telemetry or analysis
- Built-in Battery Voltage and Temperature sensors
- Power Control header for turning On or Off the controller from external microcomputer or switch
- No consumption by output stage when motors stopped
- Regulated 5V output for powering Encoders, RC radio, RF Modem or microcomputer
- Separate Programmable acceleration and deceleration for each motor
- Separate Programmable maximum forward and reverse power
- Support for CANopen and two simplified CAN protocols
- Direct connection to multi-channel 2.4GHz RC satellite receiver
- Ultra-efficient 10 mOhm ON resistance MOSFETs
- Stall detection and selectable triggered action if Amps is outside user-selected range
- Overvoltage and Undervoltage protection
- Programmable Watchdog for automatic motor shutdown in case of command loss
- Overtemperature protection
- Diagnostic LED indicators
- Efficient heat sinking using conduction bottom plate. Operates without a fan in most applications
- Power wiring via terminal strip wires up to AWG12
- 2.76" (70mm) L, 2.76" W (70mm), 0.78" (20mm) H
- -40° to +85° C operating environment
- 4.2oz (120g)
- Easy configuration, tuning and monitoring using provided PC utility
- Field upgradeable software for installing latest features via the Internet

Orderable Product References

TABLE 1.

Reference	Number of Channels	Amps/Channel	Volts	Ethernet	Resolver	USB
SDC2130	2	20	30	No	No	Yes
SDC2160	2	20	60	No	No	Yes
SDC2130S	1	40	30	No	No	Yes
SDC2160S	1	40	60	No	No	Yes

Important Safety Disclaimer

Dangerous uncontrolled motor runaway conditions can occur for a number of reasons, including, but not limited to: command or feedback wiring failure, configuration error, faulty firmware, errors in user script or user program, or controller hardware failure.

The user must assume that such failures can occur and must make their system safe in all conditions. Roboteq will not be liable in case of damage or injury as a result of product misuse or failure.

Power Wires Identifications and Connection

Power connections are made through a six position screw terminal.

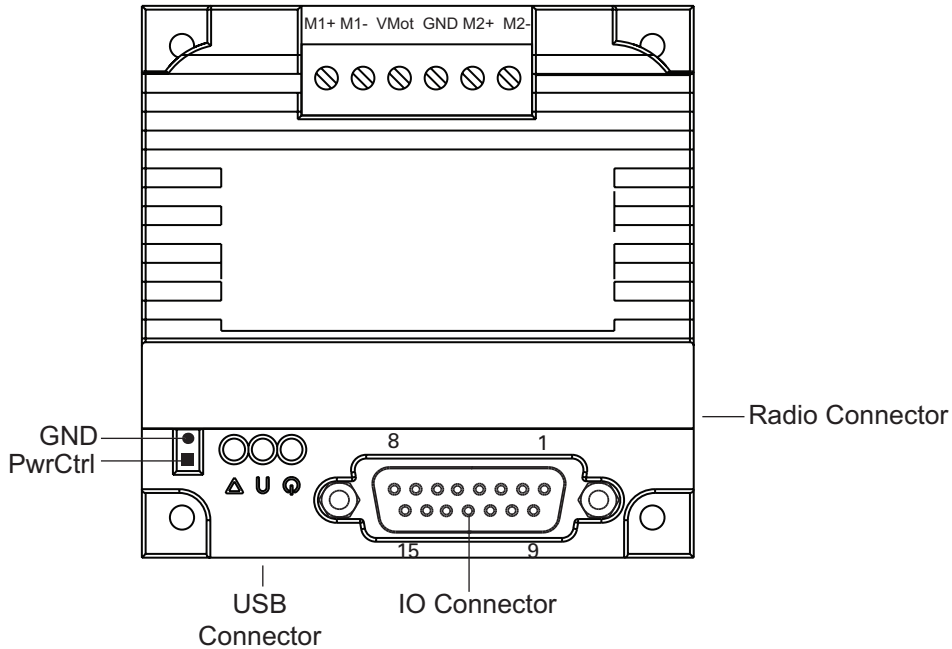

FIGURE 1. Controller Top View Layout

Figure 2, below, shows how to wire the dual-channel controller and how to turn power On and Off.

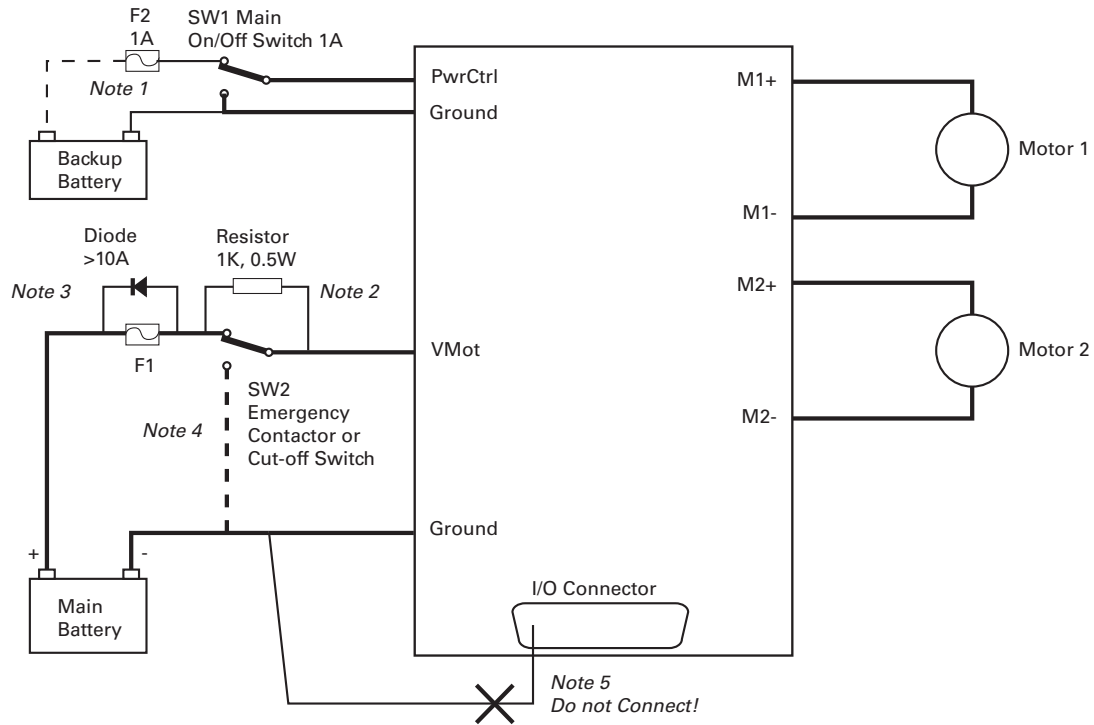

FIGURE 2. Powering the Controller. Thick lines identify **MANDATORY** connections

Important Warning

Carefully follow the wiring instructions provided in the Power Connection section of the User Manual. The information on this datasheet is only a summary.

Mandatory Connections

It is imperative that the controller is connected, as shown in Figure 2, above, in order to ensure a safe and trouble-free operation. All connections shown as thick black lines are mandatory. The controller must be powered On/Off using switch SW1 on the Power Control Header.

Emergency Switch or Contactor

The battery must be connected in permanence to the controller's VMot power via an input emergency switch or contactor SW2 as additional safety measure. The user must be able to deactivate the switch or contactor at any time, independently of the controller state.

Electrostatic Discharge Protection

In accordance with IEC 61000-6-4, Roboteq Motor Controllers are designed to withstand ESD up to 4kV touch and 8kV air gap. This protection is implemented without any additional external connections required.

Some specifications, such as EN12895, require a higher level of protection. To maximize ESD protection, up to 8kV touch and 15kV air gap, you may connect the metallic heatsink of the controller to your battery negative terminal. [See App Note 062918 for example connections.](#)

Precautions and Optional Connections

- Note 1: An optional backup battery to ensure motor operation with weak or discharged battery.
- Note 2: Use precharge 1K Resistor to prevent switch arcing.
- Note 3: Insert a high-current diode to ensure a return path to the battery during regeneration in case the fuse is blown.
- Note 4: Users have the option to ground the VMot terminal when the controller is Off. It is recommended that users do this if there is any concern that the motors could be made to spin and generate voltage in excess of 10V.
- Note 5: Beware not to create a path from the ground pins on the I/O connector and the battery's minus terminal.

Use of Safety Contactor for Critical Applications

An external safety contactor must be used in any application where damage to property or injury to person can occur because of uncontrolled motor operation resulting from failure in the controller's power output stage.

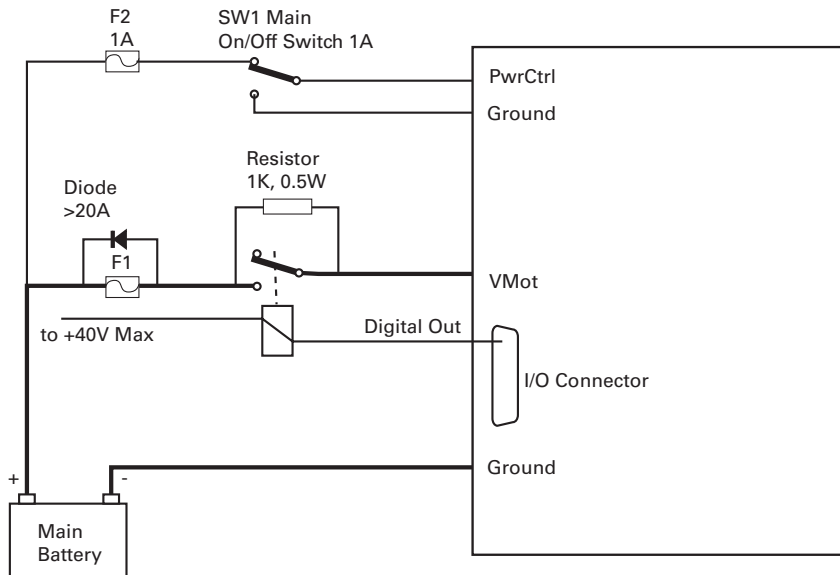

FIGURE 3. Contactor Wiring Diagram

The contactor coil must be connected to a digital output configured to activate when “No MOSFET Failure”. The controller will automatically deactivate the coil if the output is expected to be off and battery current of 500mA or more is measured for more than 0.5s. This circuit will not protect against other sources of failure such as those described in the “Important Safety Disclaimer” on Page 3.

Single Channel Wiring

The single channel version of the controller (SDC2130S and SDC2160S) require that the output be parallel and that the load be wired, as shown in Figure 4, below.

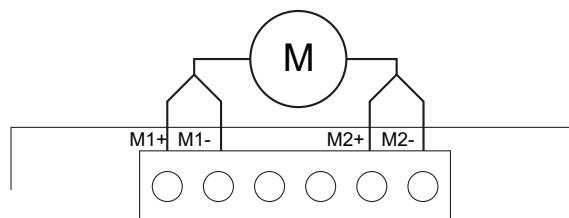

FIGURE 4. SDC2130S and SDC2160S Wiring Diagram

Important Warning

This wiring in Figure 4 is only possible on controllers fitted with the Single Channel version of the firmware. Dual channel controllers will be damaged if wired as single channel. Verify that the PC utility identifies the controller as SDC2130S or SDC2160S before applying power to the load.

Controller Mounting

During motor operation, the controller will generate heat that must be dissipated. The published amps rating can only be fully achieved if adequate cooling is provided. Good conduction cooling can be achieved by mounting the controller to a metallic surface, such as the chassis, cabinet, etc.

Sensor and Commands Connection

Connection to RC Radio, Microcomputer, Joystick and other low current sensors and actuators is done via the 15 connector located in front of the board. The functions of many pins vary depending on user configuration. Pin assignments can be found in Table 2, below.

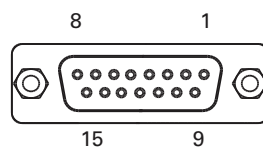

FIGURE 5. Connector Pin Locations

TABLE 2.

Connector Pin	Power	Dout	Com	RC	Ana	Dinput	Enc	Default Config
1		DOUT1						Unused
9		DOUT2						Unused
2			TxOut					RS232Tx Data
10				RC5	ANA5 (1)(2)	DIN5	ENC2A	Unused
3			RxIn					RS232Rx Data
11				RC4	ANA4	DIN4		Unused
4				RC1	ANA1 (1)(2)	DIN1	ENC1A	RCRadio1
12				RC3	ANA3	DIN3		Unused
5	GND							
13	GND							
6			CANL (3)					
14	5VOut							
7			CANH (3)					
15				RC6(1)	ANA6 (2)	DIN6	ENC2B	Unused
8				RC2	ANA2	DIN2	ENC1B	RCRadio2

Note 1: RC6, ANA5 and ANA6 present on hardware version 2.0
 Note 2: On hardware version 1, ANA1 is on Pin 10
 Note 3: On hardware version 1, CAN is only available on SDC21xxN

Pin Assignment Changes Between v1.x and v2.x

V2.x of the SDC21xx has six Analog inputs instead of four. Analog Input 1 has been moved from Pin 10 to Pin 4. If backwards compatibility is required, contact Roboteq for instruction on restoring the Version 1 pinout.

Default I/O Configuration

The SDC 21xx controller can be configured so that practically any Digital, Analog and RC pin can be used for any purpose. The controller's factory default configuration provides an assignment that is suitable for most applications. Figure 6, below, shows how to wire the controller to two analog potentiometers, an RC radio, and the RS232 port. It also shows how to connect the two outputs to motor brake solenoids. You may omit any connection that is not required in your application. The controller automatically arbitrates the command priorities depending on the presence of a valid command signal in the following order: 1-RS232, 2-RC Pulse, 3-None. If needed, use the Roborun+ PC Utility to change the pin assignments and the command priority order.

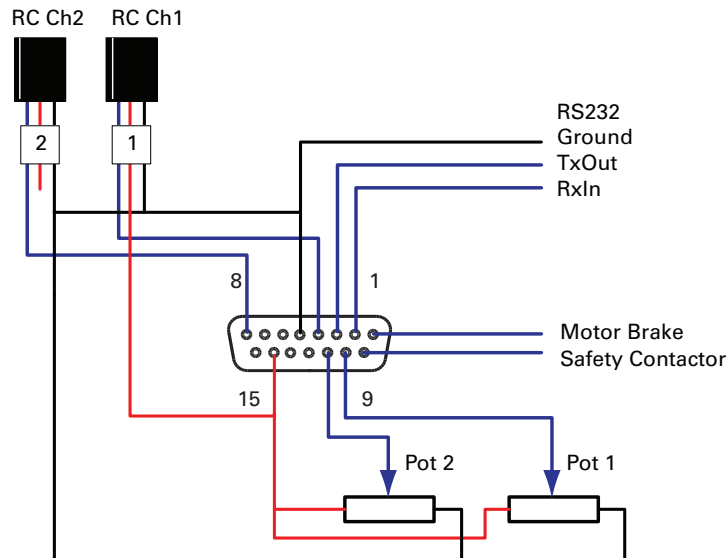

FIGURE 6. Factory Default Pin Assignments

Enabling Analog Commands

For safety reasons, the Analog command mode is disabled by default. To enable the Analog mode, use the PC utility and set Analog in Command Priority 2 or 3 (leave Serial as priority 1). Note that by default the additional securities are enabled and will prevent the motor from starting unless the potentiometer is centered, or if the voltage is below 0.25V or above 4.75V. The drawing shows suggested assignment of Pot 1 to ANA5 (ANA1 on v1.x) and Pot 2 to ANA4. Use the PC utility to enable and assign analog inputs.

CAN Bus Operation

The controller can interface with a standard CAN Bus network using 4 possible protocols: Standard CANOpen, and three simplified proprietary schemes (MiniCAN, RawCAN and RoboCAN. Please refer to the User Manual for details. On hardware version 1.x, CAN is only available on SDC21xx.

USB communication

Use USB only for configuration, monitoring and troubleshooting. USB is not a reliable communication method when used in a electrically noisy environments and communication will not always recover after it is lost without unplugging and replugging the connector, or restarting the controller. Always prefer RS232 communication when interfacing to a computer.

Serial Communication

The controller has a full RS232 compatible serial interface. On v2.x, the serial port can easily be connected to devices with TTL serial using a simple resistor and diodes circuit. See user manual for details.

Satellite Receiver Connection

A 3-pin plug is provided for direct connection to a SP9545 miniature receiver.

Status LED Flashing Patterns

The controller is equipped with three LEDs. After the controller is powered on, the Power LED will turn on, indicating that the controller is On. The Status LED will be flashing at a two second interval. The flashing pattern provides operating or exception status information.



-  Communication LED
-  Power LED
-  Status LED

FIGURE 7. LED Identifications



FIGURE 8. Normal Operation Flashing Patterns

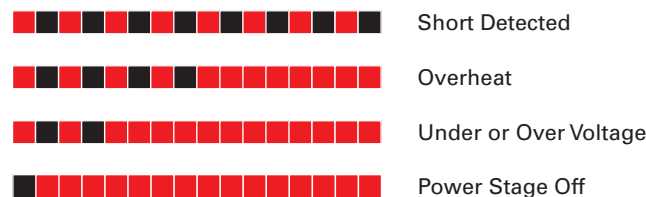

FIGURE 9. Exception or Fault Flashing Patterns

Additional status information may be obtained by monitoring the controller with the PC utility.
 Note: Red/Green LED is only in hardware Version 2.0 and newer. Version 1.0 uses monochrome LED.

The communication LED gives status information on the CAN and USB.

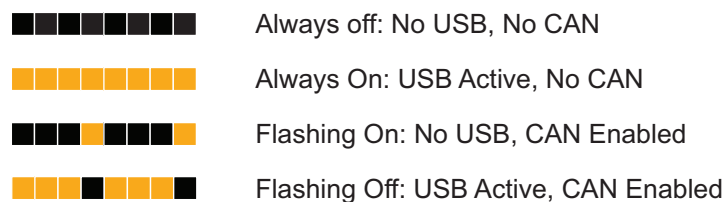

Figure 10. Communication LED

Secure Connection to AMP FASTON™ Tabs

Power Motor and Battery connections are made via standard 250mils (6.35mm) AMP FASTON™ Tabs. FASTON connectors provide a high current and very secure connection, proven over decades of use in the automotive industry. For maximum current handling, use connectors for AWG10 wires recognizable by their yellow plastic insulator.

FASTON connectors have an extremely tight fit and will not come off on their own. It is recommended, nevertheless, that the wiring is made so that the cables are never pulling the connector outward.

Frequent disconnects and reconnects will eventually loosen the connector’s grip on the tab. If frequent disconnection is required, consider using Positive Lock connectors from TE Connectivity or their equivalent. These connectors have a spring loaded tab latch pin that will lock into the hole of the male tab.

Amps Sensors

The controller has built in sensor to measure the battery amps for each channel. Motor Amps are calculated. Motor Amps precision decreases at PWM levels below 20%. Motor Amps are not measured and reported as 0 when the PWM output is at 0%.

Electrical Specifications

Absolute Maximum Values

The values in the table below should never be exceeded. Permanent damage to the controller may result.

TABLE 3.

Parameter	Measure point	Models	Min	Typical	Max	Units
Battery Leads Voltage	Ground to VMot	SDC2130	10		40	Volts
		SDC2160	10		62	Volts
Reverse Voltage on Battery Leads	Ground to VMot	All	-1			Volts
Motor Leads Voltage	Ground to M1+, M1-, M2+, M2-	SDC2130			35	Volts
		SDC2160			62	Volts
Digital Output Voltage	Ground to Output pins	All			40	Volts
Analog and Digital Inputs Voltage	Ground to any signal pin on 25 & 9-pin connectors	All			30	Volts
RS232 I/O pins Voltage	External voltage applied to Rx/Tx pins	All			30	Volts
Board Temperature	Board		-40		85	°C
Humidity	Board				100 (3)	%
Note 1: Maximum regeneration voltage in normal operation. Never inject a DC voltage from a battery or other fixed source						
Note 2: Non-condensing						

Power Stage Electrical Specifications (at 25°C ambient)

TABLE 4.

Parameter	Measure point	Models	Min	Typical	Max	Units
Battery Leads Voltage	Ground to VMot	SDC2130(S)	10 (1)		35	Volts
		SDC2160(S)	10 (1)		62	Volts
Motor Leads Voltage	Ground to M1+, M1-, M2+, M2-	SDC2130(S)	0 (1)		35(2)	Volts
		SDC2160(S)	0 (1)		62(2)	Volts
Over Voltage protection range	Ground to VMot	SDC2130(S)	5	30 (4)	35	Volts
		SDC2160(S)	5	60 (4)	62(2)	Volts
Under Voltage protection range	Ground to VMot	SDC2130(S)	0	5 (4)	35	Volts
		SDC2160(S)	0	5 (4)	62	Volts
Idle Current Consumption	VMot or Pwr Ctrl wires	All	50	75 (5)	100	mA
ON Resistance (Excluding wire resistance)	VMot to M+, plus M- to Ground at 100% power. Per channel	SDC2130/60		20		mOhm
		SDC2130S/60S		10		mOhm
Max Current per channel for 30s	Ch1 or Ch2 Motor current	SDC2130/60			20	Amps
		SDC2130S/60S			40	Amps
Continuous Max Current per channel	Ch1 or Ch2 Motor current	SDC2130/60			15 (7)	Amps
		SDC2130S/60S			30 (7)	Amps
Current Limit range	Ch1 or Ch2 Motor current	SDC2130/60	1	15 (8)	20	Amps
		SDC2130S/60S	1	30 (8)	40	Amps
Stall Detection Amps range	Ch1 or Ch2 Motor current	SDC2130/60	1	15 (8)	20	Amps
		SDC2130S/60S	1	30 (8)	40	Amps
Stall Detection timeout range	Ch1 or Ch2 Motor current	All	1	500 (9)	65000	milliseconds
Motor Acceleration/Deceleration range	Ch1 or Ch2	All	100	500 (10)	65000	milliseconds

Note 1: Negative voltage will cause a large surge current. Protection fuse needed if battery polarity inversion is possible

Note 2: Maximum regeneration voltage in normal operation. Never inject a DC voltage from a battery or other fixed source

Note 3: Minimum voltage must be present on VMot or Power Control wire

Note 4: Factory default value. Adjustable in 0.1V increments

Note 5: Current consumption is lower when higher voltage is applied to the controller's VMot or PwrCtrl wires

Note 6: Max value is determined by current limit setting. Duration is estimated and is dependent on ambient temperature cooling condition

Note 7: Estimate. Limited by heatsink temperature. Current may be higher with better cooling

Note 8: Factory default value. Adjustable in 0.1A increments

Note 9: Factory default value. Time in ms that Stall current must be exceeded for detection

Note 10: Factory default value. Time in ms for power to go from 0 to 100%

Important Warning:

Be aware that regenerative braking can create high voltage at the controller's power inputs. Use the controller only with batteries. See user manual for special precautions when using a power supply.

Command, I/O and Sensor Signals Specifications

TABLE 5.

Parameter	Measure point	Min	Typical	Max	Units
Main 5V Output Voltage	Ground to 5V pins on	4.6	4.75	4.9	Volts
5V Output Current	5V pins on RJ45 and DSub15			100	mA
Digital Output Voltage	Ground to Output pins			30	Volts
Digital Output Current	Output pins, sink current			1	Amps
Output On resistance	Output pin to ground		0.75	1.5	Ohm
Output Short circuit threshold	Output pin	1.05	1.4	1.75	Amps
Input Impedances	AIN/DIN Input to Ground		53		kOhm
Digital Input 0 Level	Ground to Input pins	-1		1	Volts
Digital Input 1 Level	Ground to Input pins	3		30	Volts
Analog Input Range	Ground to Input pins	0		5.1	Volts
Analog Input Precision	Ground to Input pins		0.5		%
Analog Input Resolution	Ground to Input pins		1		mV
Encoder Frequency				500	kHz
Pulse durations	Pulse inputs	20000		10	us
Pulse repeat rate	Pulse inputs	50		250	Hz
Pulse Capture Resolution	Pulse inputs		1		us
Frequency Capture	Pulse inputs	100		1000	Hz
Encoder count	Internal	-2.147		2.147	10 ⁹ Counts
Encoder frequency	Encoder input pins			1M(1)(2)	Counts/s
Note1: Max 30Kcounts/s on dual channel v1.x.					
Note 2: Enabling Encoder disables pulse capture					

Operating & Timing Specifications

TABLE 6.

Parameter	Measure Point	Min	Typical	Max	Units
Command Latency	Command to output change	0	0.5	1	ms
PWM Frequency	Ch1, Ch2 outputs	10	18 (1)	20	kHz
Closed Loop update rate	Internal		1000		Hz
USB Rate	USB pins			12	MBits/s
RS232 baud rate	Rx &Tx pins	9600	115200 (2)	115200	Bits/s
RS232 Watchdog timeout	Rx pin	1 (3)		65000	ms
Note 1: May be adjusted with configuration program					
Note 2: 115200, 8-bit, no parity, 1 stop bit, no flow control					
Note 3: May be disabled with value 0					

Scripting

TABLE 7.

Parameter	Measure Point	Min	Typical	Max	Units
Scripting Flash Memory	Internal		32000 (1)		Bytes
Max Basic Language programs	Internal	2000		3000	Lines
Integer Variables	Internal		4096		Words (2)
Boolean Variables	Internal		8190		Symbols
Execution Speed	Internal	50 000	100 000		Lines/s
Note 1: 8192 in Version 1 hardware					
Note 2: 32-bit words					

Thermal Specifications

TABLE 8.

Parameter	Measure Point	Model	Min	Typical	Max	Units
Board Temperature	PCB	All	-40		85 (1)	°C
Thermal Protection range	PCB	All	70		80 (2)	°C
Thermal resistance	Power MOSFETs to heats sink	All			2	°C/W
Note 1: Thermal protection will protect the controller power						
Note 2: Max allowed power out starts lowering at minimum of range, down to 0 at max of range						

The SDC21xx uses a conduction plate at the bottom of the board for heat extraction. For best results, attach firmly with thermal compound paste against a metallic chassis so that heat transfers to the conduction plate to the chassis. If no metallic surface is available, mount the controller on spacers so that forced or natural air flow can go over the plate surface to remove heat.

Mechanical Specifications

TABLE 9.

Parameter	Measure Point	Min	Typ	Max	Units
Weight	Board		120 (4.2)		g (oz.)
Power Wire Gauge	Terminal strip			12	AWG

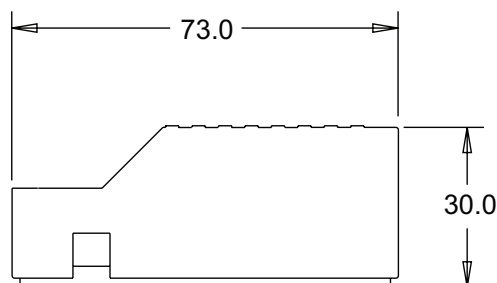

FIGURE 11. SDC21xx Front View and Dimensions

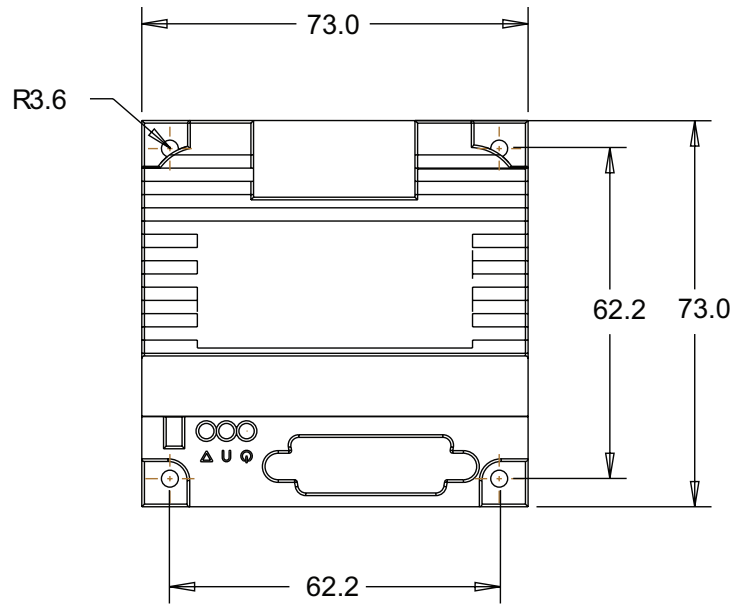

FIGURE 12. SDC21xx Top View and Dimensions