

SA4100

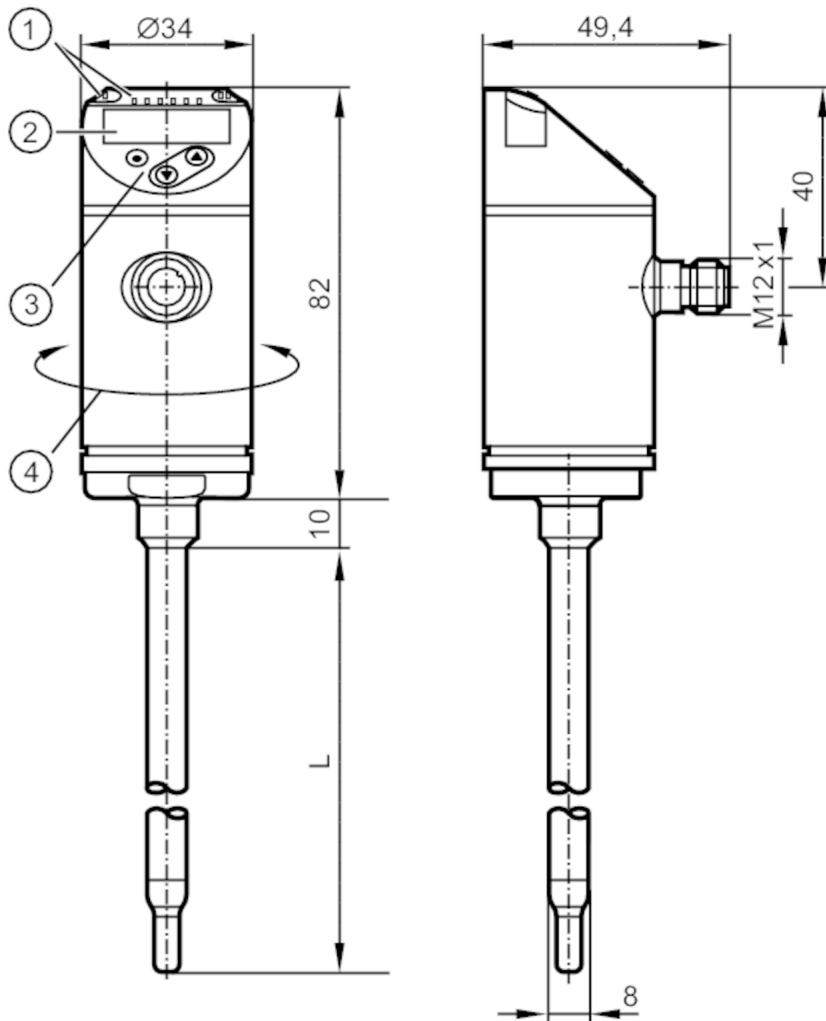

Flow sensor

SAEXXXBFRKG/US-100



- L 100 mm
- 1 LEDs Display unit / Switching status
- 2 alphanumeric display 4-digit red/green
- 3 Programming buttons
- 4 upper part of the housing can be rotated 345°

ACS CRN EC 1935/2004 FCM KTW/W270 Reg31

Product characteristics	
Number of inputs and outputs	Number of digital outputs: 2; Number of analog outputs: 1
Process connection	Diameter \varnothing 8 mm
Application	
System	gold-plated contacts
Media	water; glycol solutions; air; oils
Note on media	low-viscosity oils with viscosity: ≤ 40 mm ² /s (40 °C) high-viscosity oils with viscosity: > 40 mm ² /s (40 °C)
Medium temperature [°C]	-20...100
Pressure rating [bar]	50
Pressure rating [Mpa]	5
MAWP (for applications according to CRN) [bar]	50

SA4100



Flow sensor

SAEXXXBFRKG/US-100

Electrical data		
Operating voltage	[V]	18...30 DC
Current consumption	[mA]	< 100
Protection class		III
Reverse polarity protection		yes
Power-on delay time	[s]	10
Inputs / outputs		
Number of inputs and outputs		Number of digital outputs: 2; Number of analog outputs: 1
Outputs		
Total number of outputs		2
Output signal		switching signal; analog signal; frequency signal; IO-Link; (configurable)
Electrical design		PNP/NPN
Number of digital outputs		2
Output function		normally open / closed; (configurable)
Max. voltage drop switching output DC	[V]	2.5
Permanent current rating of switching output DC	[mA]	250
Number of analog outputs		1
Analog current output	[mA]	4...20; (scalable)
Max. load	[Ω]	350
Short-circuit protection		yes
Type of short-circuit protection		yes (non-latching)
Overload protection		yes
Frequency of the output	[Hz]	0...1000
Measuring/setting range		
Probe length L	[mm]	100
Operating mode		relative; absolutely liquid; absolutely gaseous; (absolute: reference measurement recommended)
Note on factory setting		Operating mode: relative
Liquids		
Setting range	[m/s]	0.04...6
Greatest sensitivity	[m/s]	0.04...3
Gases		
Setting range	[m/s]	0...200
Greatest sensitivity	[m/s]	2...100
Temperature monitoring		
Measuring range	[°C]	-20...100
Resolution	[°C]	0.2

SA4100



Flow sensor

SAEXXXBFRKG/US-100

Accuracy / deviations		
Flow monitoring		
Temperature drift [cm/s x 1/K]	0,003 m/s x 1/K (< 20 °C; > 70 °C)	
Max. temperature gradient of medium [K/min]	100	
Accuracy	± (7 % MW + 2 % MEW); (for relative mode in the range of maximum sensitivity under the following conditions:; water: 20...70 °C; inlet length: 1.5 m; DN25 (DIN 2448); mounting position according to instructions; Accuracy can differ for other media and mounting positions.)	
Repeatability	0,05 m/s; (water; Flow velocity: 0,05...3 m/s)	
Temperature monitoring		
Temperature drift	± 0,005 K/°C	
Accuracy [K]	± 0,3 / ± 1; (water; Flow velocity: 0,3...3 m/s / air; Flow velocity: > 10 m/s)	
Reaction times		
Flow monitoring		
Response time [s]	0.5; (T09; water; glycol: 0,8 s; air: 7 s; oil: 1,8 s; each T09)	
Temperature monitoring		
Dynamic response T05 / T09 [s]	1,5 (T09); (water; Flow velocity: 0,3...3 m/s)	
Software / programming		
Parameter setting options	hysteresis / window; normally open / closed; switching logic; current/frequency output; medium selection; Damping; Teach function; display can be rotated and switched off; standard unit of measurement; process value color	
Interfaces		
Communication interface	IO-Link	
Transmission type	COM2 (38,4 kBaud)	
IO-Link revision	1.1	
SDCI standard	IEC 61131-9	
Profiles	Smart Sensor: Process Data Variable; Device Identification, Device Diagnosis	
SIO mode	yes	
Required master port class	A	
Process data analogue	2	
Process data binary	2	
Min. process cycle time [ms]	3	
Supported DeviceIDs	Type of operation	DeviceID
	Factory setting / ModE = (REL)	533
	ModE = (LIQU)	540
	ModE = (GAS)	547
Operating conditions		
Ambient temperature [°C]	-40...80	
Storage temperature [°C]	-40...100	
Protection	IP 65; IP 67	

SA4100



Flow sensor

SAEXXXBFRKG/US-100

Tests / approvals		
EMC	DIN EN 60947-5-9	
Shock resistance	DIN EN 60068-2-27	50 g (11 ms)
Vibration resistance	DIN EN 60068-2-6	5 g (10...2000 Hz)
MTTF [years]		180
UL approval	UL approval number	I017
	File number UL	E174189

Mechanical data	
Weight [g]	298.5
Material	stainless steel (1.4404 / 316L); PBT-GF20; PBT-GF30
Materials (wetted parts)	stainless steel (1.4404 / 316L)
Process connection	Diameter Ø 8 mm

Displays / operating elements		
Display	Display unit	6 x LED, green (% , m/s, l/min, m ³ /h, °C, 10 ³)
	Switching status	2 x LED, yellow
	Measured values	alphanumeric display, red/green 4-digit

Remarks	
Remarks	MW = Measured value MEW = Final value of the measuring range
Pack quantity	1 pcs.

Electrical connection

Connector: 1 x M12; Contacts: gold-plated



SA4100



Flow sensor

SAEXXXBFRKG/US-100

Connection

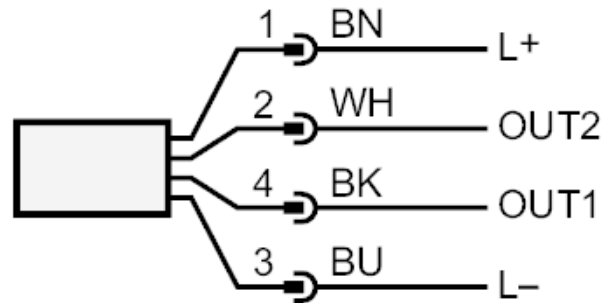

Colours to DIN EN 60947-5-2

OUT1:

- Switching output Volumetric flow quantity monitoring
- Frequency output Volumetric flow quantity monitoring
- IO-Link

OUT2:

- Switching output Volumetric flow quantity monitoring
- Switching output Temperature monitoring
- analog output Volumetric flow quantity monitoring
- analog output Temperature monitoring
- Frequency output Volumetric flow quantity monitoring
- Frequency output Temperature monitoring
- Input External Teach

Core colors :

- BK = black
- BN = brown
- BU = blue
- WH = white