

Switching Power Supply S82K

DIN-Rail Mount Power Supply with a Wide Power Range of 3 to 100 W

- Universal input voltage range.
- All models are UL 508 listed.
- Class 2 approved on all models below 100 W, except dual-output types.
- Undervoltage indicators on all models. 90-W and 100-W models have alarm and output indicators.
- PFC models meet EN61000-3-2 (limits for harmonic current emissions).
- Parallel operation capability (100 W).
- Finger-safe terminal block with cover according to VDE0106/P100.
- Approvals: UL, CSA, VDE, and CE.
- 3-year warranty.

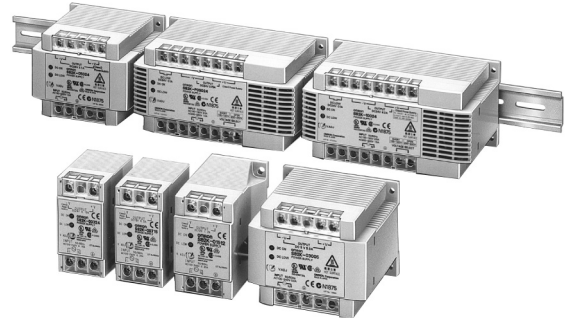

Ordering Information

■ SWITCHING POWER SUPPLIES

Stock Note: Shaded models are normally stocked.

Rated input voltage	Power ratings	Output voltage	Output current	Function configuration			Part number
				Output	Undervoltage alarm	PFC	
100 to 240 VAC	3 W	5 V	0.6 A	Single output	Indicator only	No	S82K-00305
		12 V	0.25 A				S82K-00312
		15 V	0.2 A				S82K-00315
		24 V	0.13 A				S82K-00324
	7.5 W	5 V	1.5 A	Dual output	Indicator only	No	S82K-00705
		12 V	0.6 A				S82K-00712
		15 V	0.5 A				S82K-00715
		24 V	0.3 A				S82K-00724
		+12 V/-12 V	0.3 A/0.2 A				S82K-00727
		+15 V/-15 V	0.2 A/0.2 A				S82K-00728
	15 W	5 V	2.5 A	Single output	Indicator only	No	S82K-01505
		12 V	1.2 A				S82K-01512
		24 V	0.6 A				S82K-01524

(This table continues on the next page.)

Ordering Information Table – continued from previous page

Rated input voltage	Power ratings	Output voltage	Output current	Function configuration			Part number
				Output	Undervoltage alarm	PFC	
100 to 240 VAC	30 W	5 V	5.0 A	Single output	Indicator only	No	S82K-03005
		12 V	2.5 A				S82K-03012
		24 V	1.3 A				S82K-03024
	50 W	24 V	2.1 A		S82K-05024		
120/240 VAC selectable	90 W	24 V	3.75 A	Indicator and output	Yes	No	S82K-P09024
							S82K-09024
	100 W	24V	4.2 A		Yes	S82K-P10024	
					No	S82K-10024	

■ MODEL NUMBER LEGEND

S82K -
 1 2 3 4

1. Power Factor Correction

None: No
 P: Yes

2. Power Ratings

003: 3 W
 007: 7.5 W
 015: 15 W
 030: 30 W
 050: 50 W
 090: 90 W
 100: 100 W

3. Output Voltage

05: +5 VDC
 12: +12 VDC
 15: +15 VDC
 24: +24 VDC
 27: Dual output +12/-12 VDC
 28: Dual output +15/-15 VDC

4. Undervoltage alarm indicator/output

<For 3- to 100-W models>
 None: Yes
 <For 240-W models>
 None: No
 T: Yes

■ ACCESSORIES (SOLD SEPARATELY)

Stock Note: Shaded models are normally stocked.

Noise Filter

Item	Applicable power supply	Part number
Noise filter	3- to 50-W models	S82Y-JF3-N
	90-W and 100-W models	S82Y-JF6-N

DIN Rail

Item	Length	Width	Part number
DIN-rail (See <i>Dimensions</i> section for details.)	0.5 m (1.64 ft)	7.3 mm (0.29 in)	PFP-50N
	1 m (3.28 ft)	7.3 mm (0.29 in)	PFP-100N
	1 m (3.28 ft)	16 mm (0.63 in)	PFP-100N2

Specifications

■ NON-PFC MODELS

Item	Single output		Dual outputs	Single output				
	3 W	7.5 W		7.5 W	15 W	30 W	50 W	90 W
Efficiency (typical)	60% to 80% (Varies depending on specifications.)							
Input								
Voltage (See Note 1.)	AC	100 to 240 V (85 to 264 V)					120 V (85 to 132 V)/ 240 V (170 to 264 V) Selectable	
	DC	90 to 350 V (See Note 2.)			Not possible			
Frequency	50/60 Hz (47 to 450 Hz)							
Current (See Note 3.)	100-V input	0.15 A max.	0.25 A max.		0.45 A max.	0.9 A max.	1.3 A max.	2.5 A max.
	200-V input				0.25 A max.	0.6 A max.	0.8 A max.	1.5 A max.
Leakage current (See Note 3.)	100-V input	0.5 mA max.						
	200-V input	1 mA max.						
Inrush current (See Note 3.)	100-V input	15 A max.			25 A max.			
	200-V input	30 A max.			50 A max.			
Noise filter	Yes							
Output (See Note 4.)								
Voltage adjustment range	±10% (V.ADJ)		Not possible (See Note 5.)	±10% (V.ADJ); -10% to 15% for S82K-03012/-03024/-05024				
Ripple (See Note 3.)	2% (p-p) max.							
Input variation influence	0.5 % max. (at 85 to 264 VAC, 100% load)						0.5 % max. (at 85 to 132 VAC/ 170 to 264 VAC input, 100% load)	
Load variation influence	1.5% max. (0 to 100% load)		+V: 1.5% max. -V: 3 % max. (0 to 100% load)	1.5% max. (0 to 100% load)		1.5% max. (10 to 100% load)		
Temperature variation influence (See Note 3.)	0.05%/°C max.							
Startup time	100 ms max. (up to 90% of output voltage at rated input and output)						200 ms max.	
Hold time (See Note 3.)	20 ms min.							

(This table continues on the next page.)

- Note: 1. Use with DC voltage input is beyond the conditions of approval or conformance to applicable safety standards.
 2. Use the 7.5-W single-output models under the load of 90% max. if the voltage range is between 90 and 110 VDC.
 3. Defined with a 100% load and the rated input voltage (100 or 200 VAC).
 4. The output specification is defined at the power supply output terminals.
 5. The settings for the output voltage must be within the following range:
 +V: ±1% of the rated value
 -V: ±5% of the rated value

Specifications Table – continued from previous page

Item	Single output		Dual outputs	Single output				
	3 W	7.5 W	7.5 W	15 W	30 W	50 W	90 W	100 W
Additional functions								
Overload protection	105% to 160% (105% to 250% for dual outputs model, 101% to 111% for 90-W model) of rated load current, automatic reset (See Note 6.)							
Overvoltage protection (See Note 7.)	No							
Undervoltage alarm indicator (DC LOW indicator)	Yes (color: red)							
Undervoltage alarm output (DC LOW output)	No						Yes	
Parallel operation	Not possible						Possible (2 units max.)	
Characteristics								
Ambient temperature	Operating	See the derating curve in the <i>Engineering Data</i> section (no condensation or icing)						
	Storage	-25°C to 65°C (-13°F to 149°F) with no condensation or icing						
Ambient humidity	Operating	25% to 85%						
	Storage	25% to 90%						
Dielectric strength	3,000 VAC at 50/60 Hz for 1 min (between all inputs and outputs) 2,000 VAC at 50/60 Hz for 1 min (between all inputs and GR terminal) 1,000 VAC at 50/60 Hz for 1 min (between all outputs and GR terminal) Alarm current: 10 mA (3- to 7.5-W models) 20 mA (15- to 100-W models) 25 mA (240-W models)							
Insulation resistance	100 MΩ min. at 500 VDC (between all outputs and all inputs/GR terminal)							
Vibration resistance	Malfunction: 10 to 55 Hz, 0.375-mm (0.15-mm for 240-W model) single amplitude for 2 hrs each in X, Y, and Z directions							
Shock resistance	Malfunction: 300 m/s ² , 3 times each in ±X, ±Y, and ±Z directions							
Screw tightening torque	0.74 N • m max. (See Note 8.)							
Output indicator	Yes (green)							
Electromagnetic interference (See Note 3.)	Conforms to FCC class B						Conforms to FCC class A	

(This table continues on the next page.)

- Note: 1. Use with DC voltage input is beyond the conditions of approval or conformance to applicable safety standards.
 2. Use the 7.5-W single-output models under the load of 90% max. if the voltage range is between 90 and 110 VDC.
 3. Defined with a 100% load and the rated input voltage (100 or 200 VAC).
 4. The output specification is defined at the power supply output terminals.
 5. The settings for the output voltage must be within the following range:
 +V: ±1% of the rated value
 -V: ±5% of the rated value
 6. When using the 7.5-W single-output models within the input voltage range between 90 and 110 VDC, the protection function will operate at a current of 95% to 160% of the rated load current. When using the 90-W model under the ambient temperature over 25°C, the protection function may operate at a current of 92% to 111% of the rated load current.
 7. Circuit-breaker type. To reset, turn the input power supply OFF, then after 1 min has elapsed, turn the input power supply ON again.
 8. Do not press down on the terminal block with a force exceeding 75 N while tightening the terminals.
 9. To ensure the emission ratings, a noise filter should be used on the output lines at the closest point.
 (3- to 50-W models: S82Y-JF3-N, 90-W and 100-W models: S82Y-JF6-N)
 10. To ensure the Emission Enclosure rating, a ferrite ring core should be used on all cables (for S82K-P24024).
 11. To meet Class 2 requirement with 100-W model, either a fuse or circuit breaker that is UL listed or CSA certified, and rated at 4.2 A max. should be used in the output of the power supply. Only then can the power supply output be considered as meeting Class 2.

Specifications Table – continued from previous page

Item	Single output		Dual outputs	Single output				
	3 W	7.5 W	7.5 W	15 W	30 W	50 W	90 W	100 W
Characteristics (continued)								
EMC (See Note 9.)	3-W to 100-W models	(EMI): EN50081-1 Emission Enclosure: EN55022 class B (equivalent to EN55011 class B) Emission AC Mains: EN55022 class B (equivalent to EN55011 class B) Emission Output Ports: EN55022 class A (with a recommended optional filter) (See Note 9.)						
	240-W models	(EMI): EN50081-2 Emission Enclosure: EN55011 class A (See Note 10.) Emission AC Mains: EN55011 class A (See Note 10.) Harmonic Current: EN61000-3-2 (only for S82K-P24024)						
	Common to all models	(EMS): EN50082-2 Immunity ESD: EN61000-4-2: 4-kV contact discharge (level 2) 8-kV air discharge (level 3) Immunity Burst: EN61000-4-4: 2-kV power-line (level 3) 2-kV output line (level 4) Immunity Surge: EN61000-4-5: between 2-kV lines (except for 240-W models) between 4-kV line and FG (except for 240-W models)						
Approved standards		UL508 (Listing)/1950; Class 2 Power Supply, CE; CSA C22.2 No.14/No.950; EN50178 (VDE0160), EN60950 (Conforms to VDE0106/P100)						
		* 100-W model must have a fuse in the output to be Class 2. (See Note 11.)						
Weight	150 g max.		260 g max.	380 g max.	400 g max.	600 g max.		

- Note: 1. Use with DC voltage input is beyond the conditions of approval or conformance to applicable safety standards.
 2. Use the 7.5-W single-output models under the load of 90% max. if the voltage range is between 90 and 110 VDC.
 3. Defined with a 100% load and the rated input voltage (100 or 200 VAC).
 4. The output specification is defined at the power supply output terminals.
 5. The settings for the output voltage must be within the following range:
 +V: ±1% of the rated value
 -V: ±5% of the rated value
 6. When using the 7.5-W single-output models within the input voltage range between 90 and 110 VDC, the protection function will operate at a current of 95% to 160% of the rated load current. When using the 90-W model under the ambient temperature over 25°C, the protection function may operate at a current of 92% to 111% of the rated load current.
 7. Circuit-breaker type. To reset, turn the input power supply OFF, then after 1 min has elapsed, turn the input power supply ON again.
 8. Do not press down on the terminal block with a force exceeding 75 N while tightening the terminals.
 9. To ensure the emission ratings, a noise filter should be used on the output lines at the closest point.
 (3- to 50-W models: S82Y-JF3-N, 90-W and 100-W models: S82Y-JF6-N)
 10. To ensure the Emission Enclosure rating, a ferrite ring core should be used on all cables (for S82K-P24024).
 11. To meet Class 2 requirement with 100-W model, either a fuse or circuit breaker that is UL listed or CSA certified, and rated at 4.2 A max. should be used in the output of the power supply. Only then can the power supply output be considered as meeting Class 2.

■ PFC MODELS (S82K-P□□□24)

Notes below this table apply to this page only.

Item		Single output	
Power Rating		90 W	100 W
Efficiency (typical)		60% to 80% (Varies depending on specifications.)	
Input			
Voltage		120 V (85 to 132 VAC)/240 V (170 to 264 VAC) Selectable	
Frequency		50/60 Hz (47 to 63 Hz)	
Current (See Note 1.)	100-V input	2.5 A max.	
	200-V input	1.0 A max.	
Power factor	100-V input	---	
	200-V input	0.7 min.	
Leakage current (See Note 1.)	100-V input	0.5 mA max.	
	200-V input	1 mA max.	
Inrush current (See Note 1.)	100-V input	25 A max.	
	200-V input	50 A max.	
Noise filter		Yes	
Output (See Note 2.)			
Voltage adjustment range		±10% (V.ADJ)	
Ripple (See Note 1.)		2% (p-p) max.	
Input variation influence		0.5% max. (at 85 to 132 VAC/170 to 264 VAC input, 100% load)	
Load variation influence		1.5% max. (0 to 100% load)	
Temperature variation		0.05%/°C max.	
Start up time		200 ms max.	
Hold time (See Note 1.)		20 ms min.	
Additional function			
Overload protection		101% to 111% of rated load current, inverted L drop, automatic reset (See Note 3.)	105% to 160% of rated load current, inverted L drop, automatic reset
Overvoltage protection		No	
Under voltage alarm indicator		Yes (color: red)	
Under voltage alarm output		Yes	
Parallel operation		Impossible	Possible (2 units max.) (See Note 4.)

(PFC specifications table continues on the next page.)

- Note: 1. Defined with a 100% load and the rated input voltage (100 or 200 VAC)
 2. The output specification is defined at the power supply output terminals.
 3. When the ambient temperature exceeds 25°C, the protection function may operate at a current of 92% to 111% of the rated load current.
 4. Parallel operation is set with the Parallel/Single Operation Selector Switch.
 5. MTBF minimum 135,000 hours – by calculating the failure rate of each component within the unit. Expected life 8 years – measuring the reliability of the unit.

Specifications Table PFC Models (S82K-P□□□24) – continued from previous page

Item	Single output	
Power Rating	90 W	100 W
Characteristics		
Ambient temperature	Operating	See the derating curve in the Engineering Data section (no condensation or icing)
	Storage	-25°C to 65°C (no condensation or icing)
Ambient humidity	Operating	25% to 85%
	Storage	25% to 90%
Dielectric strength	3,000 VAC at 50/60 Hz for 1 min. (between all inputs and outputs) 2,000 VAC at 50/60 Hz for 1 min. (between all inputs and GR terminal) 1,000 VAC at 50/60 Hz for 1 min. (between all outputs and GR terminal) Alarm current: 20 mA (90- and 100-W models) 25 mA (240-W models)	
Insulation resistance	100 MΩ min. at 500 VDC (between all outputs and all inputs/GR terminal)	
Vibration resistance	Malfunction: 10 to 55 Hz, 0.375-mm single amplitude for 2 hrs each in X, Y, and Z directions	
Shock resistance	Malfunction: 150 m/s ² , 3 times each in ±X, ±Y, and ±Z directions	
Screw tightening torque	0.74 N • m max. (See Note 2.)	
Output indicator	Yes (Green)	
Electromagnetic interference (See Note 1.)	Conforms to FCC class A	
EMC (See Notes 3, 4.)	<p><u>90-, 100-W Models</u> (EMI): EN50081-1 Harmonic Current: EN61000-3-2 (200 VAC input only) Emission Enclosure: EN55022 class B Emission AC Mains: EN55022 class B Emission Output Ports: EN55022 class A (with a recommended optional filter) (See Note 3.)</p> <p><u>240-W Model</u> (EMI): EN50081-2 Harmonic Current: EN61000-3-2 Emission Enclosure: EN55011 class A (See Note 4.) Emission AC Mains: EN55011 class A</p> <p><u>Common to All Models</u> (EMS): EN50082-2 Immunity ESD: EN61000-4-2: 4-kV contact discharge (level 2) 8-kV air discharge (level 3) Immunity Burst: EN61000-4-4: 2-kV power-line (level 3) 2-kV output line (level 4) Immunity Surge: EN61000-4-5: between 2-kV lines (except for 240-W models) between 4-kV line and FG (except for 240-W models)</p>	
Approved standards	UL508 (Listing)/1950 Class 2 (UL1310)/Class 2 (CSA C22.2 No. 950) (See Note 5.) CSA C22.2 No. 14/No. 950, EN50178 (VDE160), EN60950 Conforms to VDE0106/P100	
Weight	1,000 g max.	

(The notes below apply to this page only.)

- Note: 1. Defined with a 100% load and the rated input voltage (100 or 200 VAC)
 2. Do not press down on the terminal block with a force exceeding 75 N while tightening the terminals.
 3. To ensure the Emission Enclosure ratings, a noise filter should be used on the output lines at the closest point. (90- and 100-W models: S82Y-JF6-N)
 4. To ensure the Emission Enclosure rating, a ferrite ring core should be used on all cables.
 5. To meet Class-2 requirements with the 100-W model, either a fuse or circuit breaker that is UL listed or CSA certified, and rated at 4.2 A max. should be used in the output of the power supply. Only then can the power supply output be considered as meeting Class 2.

Mounting Position

The *derating curve* can be ensured for these two kinds of installations.

(A) Standard (Vertical) Installation

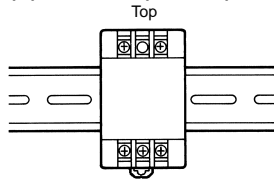

(B) Horizontal Installation

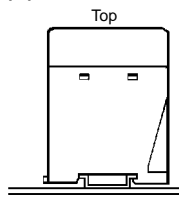

Note: Horizontal installation is not permitted for 240-W models.

OVERLOAD PROTECTION

The Power Supply is provided with an overload protection function that protects the load and the power supply from possible damage by overcurrent. When the output current rises above a set value (refer to the table below), the protection function is triggered, decreasing the output voltage. When the output current falls within the rated range, the overload protection function is automatically cleared.

	Single output		Dual outputs	Single output				
	3 W	7.5 W	7.5 W	15 W	30 W	50 W	90 W	100 W
Set value	105% to 160% of rated load current (See Note 1.)		105% to 250% of rated load current	105% to 160% of rated load current			101% to 111% of rated load current (See Notes 2 and 3.)	105% to 160% of rated load current (See Note 3.)
Operation	Inverted L drop type, automatic reset				Inverted L drop/intermittent operation type, automatic reset		Inverted L drop type, automatic reset	

- Note: 1. When using the 7.5-W single-output models within the input voltage range between 90 and 110 VDC, the overload protection function will operate at currents from 95% to 160% of the rated load current.
 2. When using the 90-W model at an ambient temperature exceeding 25°C, the overload protection function will operate at currents from 92% to 111% of the rated load current.
 3. When using the 100-W model with PFC in parallel operation, the overload protection function will operate at currents from 3.78 to 4.2 A.

3-/7.5-/15-/90-/100-W Models

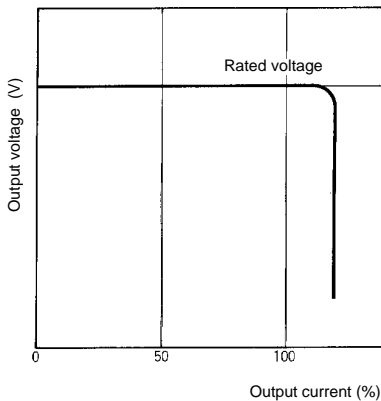

30-/50-W Models

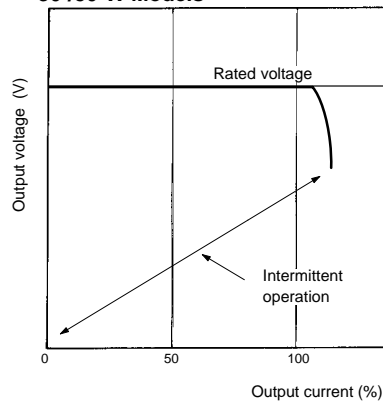

Note: Do not short-circuit the output terminals of the S82K or use the S82K with excessive output current for a long time, otherwise the internal circuitry of the S82K may be deteriorated or damaged.

When Using Dual Output (+/-) Models

The +V output detects the total output power (+V output and -V output) to trigger the short-circuit protection against overcurrent. This protection varies depending on the -V output state. The -V output independently triggers the short-circuit protection.

■ **OVERVOLTAGE PROTECTION (S82K-24024T ONLY)**

The Power Supply is provided with an overvoltage protection function that protects the load and the Power Supply from possible damage by overvoltage. When the output voltage rises above a set value, the protection function is triggered, shutting off the output voltage. If this occurs, reset the Power Supply by turning it off for 1 minute min. and then turning it on again.

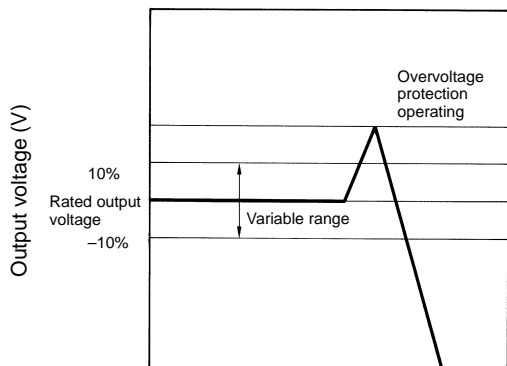

■ **INRUSH CURRENT, STARTUP TIME, HOLD TIME**

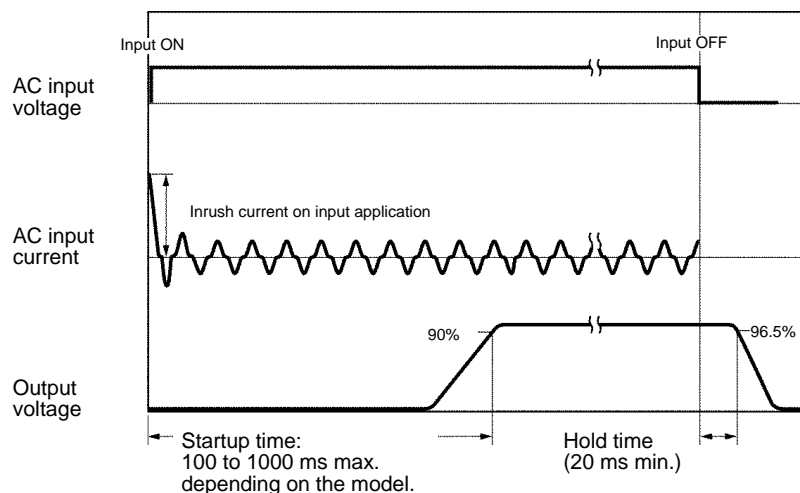

Operation

■ UNDERVOLTAGE ALARM INDICATOR AND OUTPUT FUNCTION (ALL MODELS)

If the output voltage at the output terminal drops to 75% to 90% of the rated voltage, the red indicator of the S82K (DC LOW indicator) will be lit. In the case of the 90-W and 100-W, a voltage drop alarm will be output via the relay available in the models (DC LOW output).

This function detects the voltage at the output terminal of the Power Supply. To check the precise output voltage, measure the voltage at the terminal of the load.

Indicator	Voltage	Operation of 90-W, 100-W output (DC LOW output) (See Note 2.)
Green: DC ON Red: DC LOW	If the voltage at the output terminal is more than 82% of the rated voltage and operation is normal, the green indicator will be lit and the red indicator will not be lit.	
Green: DC ON Red: DC LOW (See Note 1.)	If the voltage at the output terminal drops to below 82% of the rated voltage, the red indicator will be lit. (See Note 3.)	
Green: DC ON Red: DC LOW	If the voltage at the output terminal is 0 V, both the green and red indicators will not be lit.	

- Note: 1. The more the voltage at the output terminal drops, the darker both the green and red indicators will be.
 2. The relay contacts have a capacity of 0.1 A at 24 VDC.
 3. The red indicator will actually first light at a voltage between 75% and 90% of the rated voltage.

■ BLOCK DIAGRAMS

S82K-003□□ (3 W)

S82K-007□□ (7.5 W, Single Output)

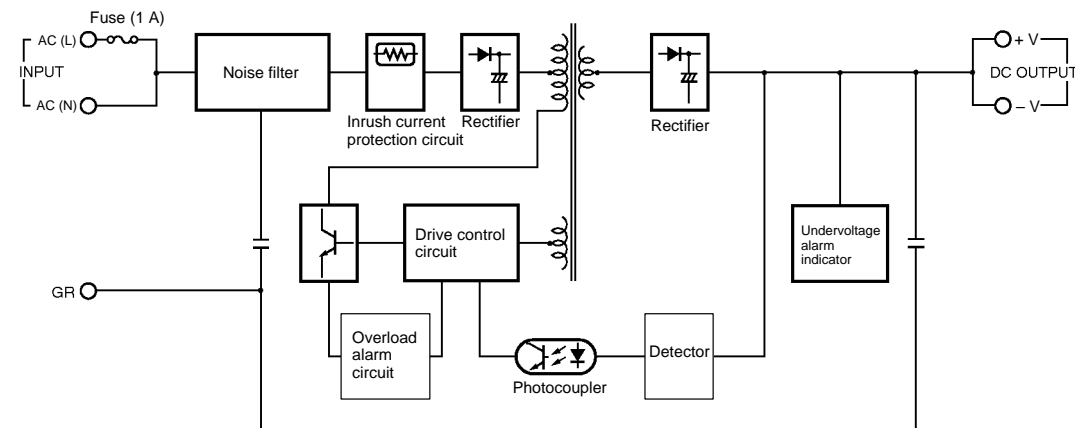

S82K-007□□ (7.5 W, Dual Outputs)

