

S3C2412X

**32-BIT CMOS
MICROCONTROLLER
Application Note
- Power Design Guide -**

Revision 1.0



ELECTRONICS

Important Notice

The information in this publication has been carefully checked and is believed to be entirely accurate at the time of publication. Samsung assumes no responsibility, however, for possible errors or omissions, or for any consequences resulting from the use of the information contained herein.

Samsung reserves the right to make changes in its products or product specifications with the intent to improve function or design at any time and without notice and is not required to update this documentation to reflect such changes.

This publication does not convey to a purchaser of semiconductor devices described herein any license under the patent rights of Samsung or others.

Samsung makes no warranty, representation, or guarantee regarding the suitability of its products for any particular purpose, nor does Samsung assume any liability arising out of the application or use of any product or circuit and specifically disclaims any and all liability, including without limitation any consequential or incidental damages.

SC32442A 32-Bit CMOS Microcontroller
Application Note, Revision 1
Publication Number: 41-S3-C2442A-082004

© 2004 Samsung Electronics

All rights reserved. No part of this publication may be reproduced, stored in a retrieval system, or transmitted in any form or by any means, electric or mechanical, by photocopying, recording, or otherwise, without the prior written consent of Samsung Electronics.

Samsung Electronics' microcontroller business has been awarded full ISO-14001 certification (BVQ1 Certificate No. 9330). All semiconductor products are designed and manufactured in accordance with the highest quality standards and objectives.

Samsung Electronics Co., Ltd.
San #24 Nongseo-Ri, Giheung- Eup
Yongin-City, Gyeonggi-Do, Korea
C.P.O. Box #37, Suwon 449-900
TEL: (82)-(031)-209-1490
FAX: (82) (331) 209-1909
Home-Page URL: [Http://www.samsungsemi.com/](http://www.samsungsemi.com/)
Printed in the Republic of Korea

"Typical" parameters can and do vary in different applications. All operating parameters, including "Typicals" must be validated for each customer application by the customer's technical experts.

Samsung products are not designed, intended, or authorized for use as components in systems intended for surgical implant into the body, for other applications intended to support or sustain life, or for any other application in which the failure of the Samsung product could create a situation where personal injury or death may occur.

Should the Buyer purchase or use a Samsung product for any such unintended or unauthorized application, the Buyer shall indemnify and hold Samsung and its officers, employees, subsidiaries, affiliates, and distributors harmless against all claims, costs, damages, expenses, and reasonable attorney fees arising out of, either directly or indirectly, any claim of personal injury or death that may be associated with such unintended or unauthorized use, even if such claim alleges that Samsung was negligent regarding the design or manufacture of said product.

Table of Contents

Chapter 1 Power Design Guide

<u>Overview</u>	2
<u>Recommended operating conditions</u>	3
<u>Power schematic decsign for dvs</u>	4
<u>DVS software operating guide</u>	7
<u>Power Consumption of DVS</u>	8

1. POWER DESIGN GUIDE

1-1. OVERVIEW

DVS(Dynamic Voltage Scaling) is useful to reduce power consumption in Idle mode & Stop mode.

The basic concept of DVS is to drop the Core and Internal voltage and reduce the power consumption when those blocks don't need to operate heavily.

There are two methods to reduce power consumption; one is drop the voltage while the internal blocks does not work or the system operates slowly. The other is lengthening the system clock speed to reduce power consumption.

DVS uses the two methods, voltage scaling and change clocking.

1-2. RECOMMENDED OPERATING CONDITIONS

Table 1-1 Recommended Operating Conditions

Parameter	Symbol	Min	Typ	Max	Unit
DC Supply Voltage for Alive Block:200MHz	VDDALIVE	1.15	1.25	1.35	V
DC Supply Voltage for Alive Block:266MHz	VDDALIVE	1.15	1.25	1.5	
DC Supply Voltage for internal	ARMCLK / HCLK				
	266 / 133 Mhz	VDDI VDDI_MPLL VDDI_UPLL	1.15	1.25	1.50
	200 / 100 Mhz	VDDI VDDI_MPLL VDDI_UPLL	1.15	1.25	1.35
	133 / 133 Mhz	VDDI VDDI_MPLL VDDI_UPLL	1.15	1.25	1.50
	100 / 100 Mhz	VDDI VDDI_MPLL VDDI_UPLL	1.15	1.25	1.50
	66 / 66 Mhz	VDDI VDDI_MPLL VDDI_UPLL	1.10	1.15	1.35
	50 / 50 Mhz	VDDI VDDI_MPLL VDDI_UPLL	1.10	1.15	1.35
DC Supply Voltage for ARM Core	ARMCLK / HCLK				
	266 / 133 Mhz	VDDI VDDI_MPLL VDDI_UPLL	1.30	1.40	1.50
	200 / 100 Mhz	VDDI VDDI_MPLL VDDI_UPLL	1.15	1.25	1.35
	133 / 133 Mhz	VDDI VDDI_MPLL VDDI_UPLL	1.15	1.25	1.35
	100 / 100 Mhz	VDDI VDDI_MPLL VDDI_UPLL	1.15	1.25	1.35
	66 / 66 Mhz	VDDI VDDI_MPLL VDDI_UPLL	1.10	1.15	1.35

Parameter	Symbol	Min	Typ	Max	Unit	
	50 / 50 Mhz	VDDI VDDI_MPLL VDDI_UPLL	1.10	1.15	1.35	
DC Supply Voltage for I/O Block	VDDOP1,2	2.3	2.5V / 2.8V / 3.3V	3.6		
DC Supply Voltage for I/O Block	VDDOP3,4	3.0	3.3V	3.6		
DC Supply Voltage for Memory Interface	VDDMOP	1.7	1.8V / 2.5V / 3.3V	3.6		
DC Supply Voltage for RTC	RTCVDD	2.5V	3.0V	3.6		
DC Supply Voltage for ADC	VDDA_ADC	3.3-5%	3.3 V	3.3+5%		
DC Input Voltage	VIN	3.0	3.3 V	3.6		
		2.3	2.5 V	2.7		
		1.7	1.8 V	1.9		
DC Output Voltage	VOUT	3.0	3.3 V	3.6		
		2.3	2.5 V	2.7		
		1.7	1.8 V	1.9		
Operating Temperature	TA	Extend ed	-20 to 70		°C	
		Industri al	-40 to 85		°C	

NOTES:

- VDDOP includes VDDOP1, VDDOP2, VDDOP3, VDDOP4
- VDDMOP includes VDDMOP1, VDDMOP2, VDDMOP3, VDDMOP4, VDDMOP5, VDDMOP6, VDDMOP7.
- DC input/output voltage is depend on the voltage of IO supply voltage corresponding IOs.
- Load Capacitance(CL) < 50pF. If max CL is changed, above operation conditions must be changed.

*; The specification especially related with VDDIARM is a preliminary. So, It can be changed.

1-3. POWER SCHEMATIC DESIGN FOR DVS

Applicable DVS power supply pins are VDDi(Internal block power) and VDDiarm(ARM926EJS power). To use DVS, the system power has to be supplied two variable voltages. One for normal operation, the other for lower level voltage (for DVS). The DVS High and Low voltage is as follows.

Table 1-2. DVS voltage level

DVS Pins	Voltage spec.	Normal operating voltage	DVS low voltage
VDDiarm VDDi/VDDmpl/VDDupll	266MHz: 1.4V(1.26V ~ 1.55V)	266MHz: 1.4V	1.15V

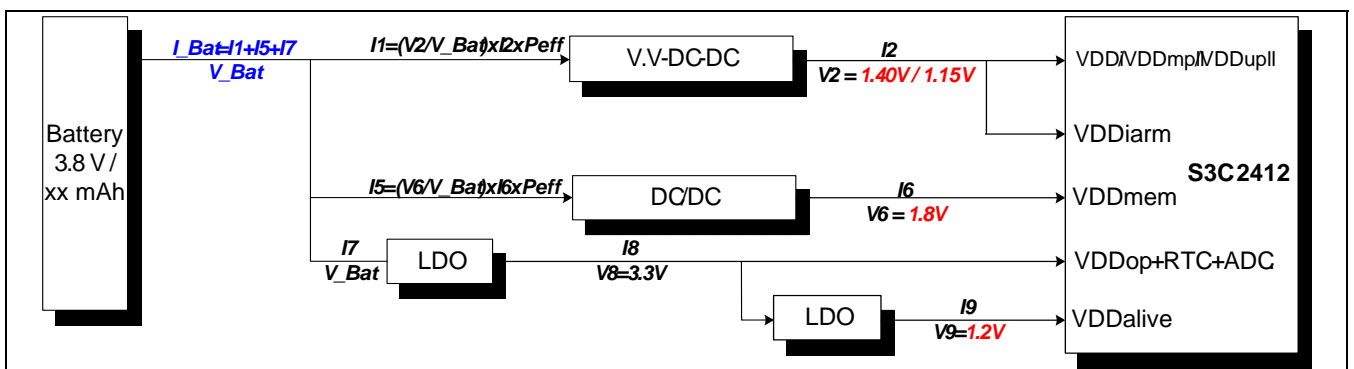

Figure 1-1. Power Scheme Diagram : 266MHz

Hardware Implementation of DVS

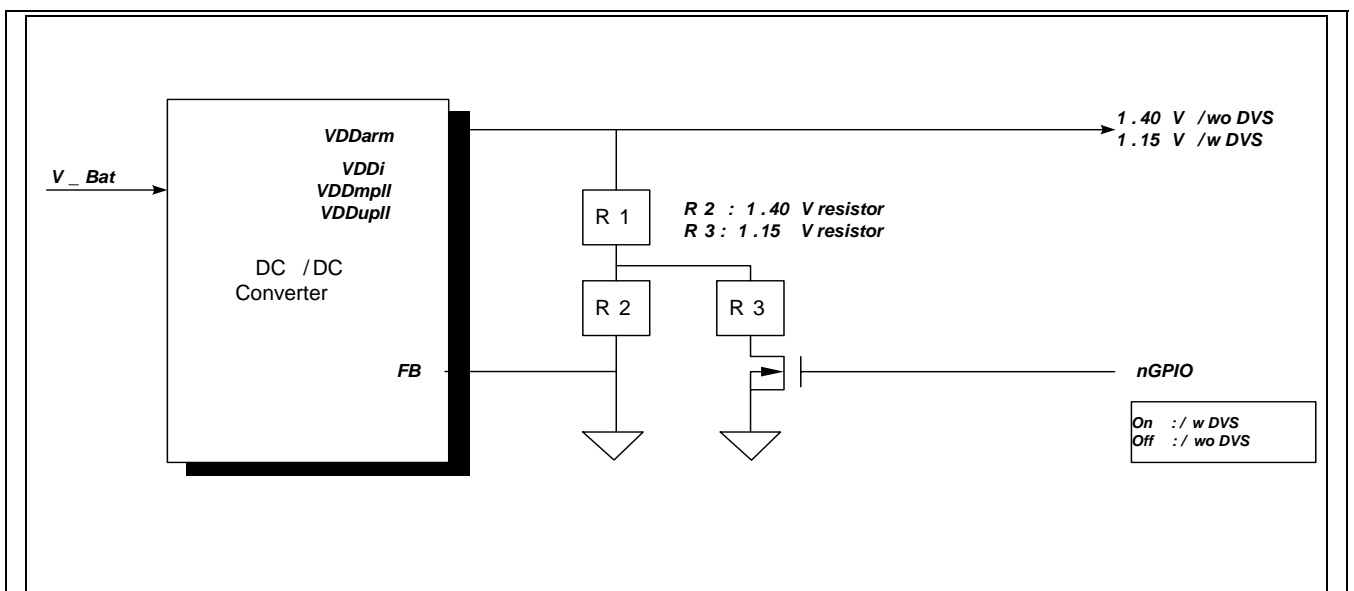

Figure 1-3. Power Scheme Diagram :266MHz

1-4. DVS SOFTWARE OPERATING GUIDE

Refer to DVS software application note

1-5. POWER CONSUMPTION OF DVS

Table 1-3 shows how much the power consumption will be reduced when using DVS for Linux.

Table 1-3. Core current Consumption

DVS Type	OS Idle State	Core Power [mW]	Difference Without→with
A	DVS Off	214.8	113.8mW(53%↓)
	DVS On	101.0	
AI	DVS Off	79.4	27.4mW(34.5%↓)
	DVS On	52	
B	DVS Off	214.8	154.3mW(71.8%↓)
	DVS On	60.5	

NOTE: Type AI is Type A with CPU Idle

Test condition:

- Core Voltage = VDDi = 1.4V, VDDiarm = 1.4V
(Voltage of VDDUPLL/VDDMPLL are same with Core Voltage).
- For DVS the Core voltage will be down to 1.15V
- (1) No threads ready to run on Linux 2.6.16.11
- (2) OS idle mode : FCLK:HCLK:PCLK = (266:133:66), (133:133:66) MHz for 266MHz in Type A
(266:133:66), (133:133:66) MHz for 266MHz in Type AI.
(266:133:66), (66:66:66) MHz for 266MHz. In Type B
- (3) Sample # : NZO75NN
OS timer scheduler: 10msec.