



S34ML01G2
S34ML02G2
S34ML04G2

1 Gb, 2 Gb, 4 Gb, 3 V, 4-bit ECC, SLC NAND Flash Memory for Embedded

Distinctive Characteristics

■ Density

- 1 Gbit / 2 Gbit / 4 Gbit

■ Architecture

- Input / Output Bus Width: 8-bits / 16-bits
- Page Size:
 - x8:
 - 1 Gbit: (2048 + 64) bytes; 64-byte spare area
 - 2 Gbit / 4 Gbit: (2048 + 128) bytes; 128-byte spare area
 - x16:
 - 1 Gbit: (1024 + 32) words; 32-word spare area
 - 2 Gbit / 4 Gbit (1024 + 64) words; 64-word spare area
- Block Size: 64 Pages
 - x8:
 - 1 Gbit: 128k + 4k bytes
 - 2 Gbit / 4 Gbit: 128k + 8k bytes
 - x16:
 - 1 Gbit: 64k + 2k words
 - 2 Gbit / 4 Gbit: 64k + 4k words
- Plane Size
 - x8
 - 1 Gbit: 1024 Blocks per Plane or (128M + 4M) bytes
 - 2 Gbit: 1024 Blocks per Plane or (128M + 8M) bytes
 - 4 Gbit: 2048 Blocks per Plane or (256M + 16M) bytes
 - x16:
 - 1 Gbit: 1024 Blocks per Plane or (64M + 2M) words
 - 2 Gbit: 1024 Blocks per Plane or (64M + 4M) words
 - 4 Gbit: 2048 Blocks per Plane or (128M + 8M) words

- Device Size

- 1 Gbit: 1 Plane per Device or 128 Mbyte
- 2 Gbit: 2 Planes per Device or 256 Mbyte
- 4 Gbit: 2 Planes per Device or 512 Mbyte

■ NAND Flash Interface

- Open NAND Flash Interface (ONFI) 1.0 compliant
- Address, Data, and Commands multiplexed

■ Supply Voltage

- 3.3V device: $V_{CC} = 2.7V \sim 3.6V$

■ Security

- One Time Programmable (OTP) area
- Serial number (unique ID) (Contact factory for support)
- Hardware program/erase disabled during power transition

■ Additional Features

- 2 Gb and 4 Gb parts support Multiplane Program and Erase commands
- Supports Copy Back Program
- 2 Gb and 4 Gb parts support Multiplane Copy Back Program
- Supports Read Cache

■ Electronic Signature

- Manufacturer ID: 01h

■ Operating Temperature

- Industrial: -40°C to 85°C
- Industrial Plus: -40°C to 105°C

Performance

■ Page Read / Program

- Random access: 25 μ s (Max) (**S34ML01G2**)
- Random access: 30 μ s (Max) (**S34ML02G2, S34ML04G2**)
- Sequential access: 25 ns (Min)
- Program time / Multiplane Program time: 300 μ s (Typ)

■ Block Erase (**S34ML01G2**)

- Block Erase time: 3 ms (Typ)

■ Block Erase / Multiplane Erase (**S34ML02G2, S34ML04G2**)

- Block Erase time: 3.5 ms (Typ)

■ Reliability

- 100,000 Program / Erase cycles (Typ)
(with 4-bit ECC per 528 bytes (x8) or 264 words (x16))
- 10 Year Data retention (Typ)
- Blocks zero and one are valid and will be valid for at least 1000 program-erase cycles with ECC

■ Package Options

- Lead Free and Low Halogen
- 48-Pin TSOP 12 x 20 x 1.2 mm
- 63-Ball BGA 9 x 11 x 1 mm
- 67-Ball BGA 8 x 6.5 x 1 mm (**S34ML01G2, S34ML02G2**)

Contents

Distinctive Characteristics	1	5.6 DC Characteristics	37
Performance	1	5.7 Pin Capacitance	37
1. General Description	3	5.8 Program / Erase Characteristics	38
1.1 Logic Diagram	4	6. Timing Diagrams	39
1.2 Connection Diagram	5	6.1 Command Latch Cycle	39
1.3 Pin Description	7	6.2 Address Latch Cycle	40
1.4 Block Diagram	8	6.3 Data Input Cycle Timing	40
1.5 Array Organization	9	6.4 Data Output Cycle Timing (CLE=L, WE#=H, ALE=L, WP#=H)	41
1.6 Addressing	11	6.5 Data Output Cycle Timing (EDO Type, CLE=L, WE#=H, ALE=L)	42
1.7 Mode Selection	14	6.6 Page Read Operation	42
2. Bus Operation	14	6.7 Page Read Operation (Interrupted by CE#)	43
2.1 Command Input	14	6.8 Page Read Operation Timing with CE# Don't Care	44
2.2 Address Input	14	6.9 Page Program Operation	44
2.3 Data Input	15	6.10 Page Program Operation Timing with CE# Don't Care	45
2.4 Data Output	15	6.11 Page Program Operation with Random Data Input	45
2.5 Write Protect	15	6.12 Random Data Output In a Page	46
2.6 Standby	15	6.13 Multiplane Page Program Operation — S34ML02G2 and S34ML04G2	46
3. Command Set	16	6.14 Block Erase Operation	47
3.1 Page Read	17	6.15 Multiplane Block Erase — S34ML02G2 and S34ML04G2	48
3.2 Page Program	17	6.16 Copy Back Read with Optional Data Readout	49
3.3 Multiplane Program — S34ML02G2 and S34ML04G2	18	6.17 Copy Back Program Operation With Random Data Input	49
3.4 Page Reprogram	18	6.18 Multiplane Copy Back Program — S34ML02G2 and S34ML04G2	50
3.5 Block Erase	20	6.19 Read Status Register Timing	51
3.6 Multiplane Block Erase — S34ML02G2 and S34ML04G2	20	6.20 Read Status Enhanced Timing	52
3.7 Copy Back Program	21	6.21 Reset Operation Timing	52
3.8 Read Status Register	22	6.22 Read Cache	53
3.9 Read Status Enhanced — S34ML02G2 and S34ML04G2	22	6.23 Cache Program	55
3.10 Read Status Register Field Definition	22	6.24 Multiplane Cache Program — S34ML02G2 and S34ML04G2	56
3.11 Reset	23	6.25 Read ID Operation Timing	58
3.12 Read Cache	23	6.26 Read ID2 Operation Timing	58
3.13 Cache Program	24	6.27 Read ONFI Signature Timing	59
3.14 Multiplane Cache Program — S34ML02G2 and S34ML04G2	25	6.28 Read Parameter Page Timing	59
3.15 Read ID	25	6.29 Read Unique ID Timing (Contact Factory)	60
3.16 Read ID2	28	6.30 OTP Entry Timing	60
3.17 Read ONFI Signature	28	6.31 Power On and Data Protection Timing	61
3.18 Read Parameter Page	29	6.32 WP# Handling	61
3.19 Read Unique ID (Contact Factory)	31	7. Physical Interface	62
3.20 One-Time Programmable (OTP) Entry	32	7.1 Physical Diagram	62
4. Signal Descriptions	32	8. System Interface	65
4.1 Data Protection and Power On / Off Sequence	32	9. Error Management	67
4.2 Ready/Busy	33	9.1 System Bad Block Replacement	67
4.3 Write Protect Operation	34	9.2 Bad Block Management	68
5. Electrical Characteristics	35	10. Ordering Information	69
5.1 Valid Blocks	35	11. Document History	70
5.2 Absolute Maximum Ratings	35		
5.3 Recommended Operating Conditions	35		
5.4 AC Test Conditions	35		
5.5 AC Characteristics	36		

1. General Description

The S34ML01G2, S34ML02G2, and S34ML04G2 series is offered with a 3.3V VCC power supply, and with x8 or x16 I/O interface. Its NAND cell provides the most cost-effective solution for the solid state mass storage market. The memory is divided into blocks that can be erased independently so it is possible to preserve valid data while old data is erased. The page size for x8 is (2048 + spare) bytes; for x16 (1024 + spare) words.

To extend the lifetime of NAND flash devices, the implementation of an ECC is mandatory.

The chip supports CE# don't care function. This function allows the direct download of the code from the NAND flash memory device by a microcontroller, since the CE# transitions do not stop the read operation.

The devices have a Read Cache feature that improves the read throughput for large files. During cache reading, the devices load the data in a cache register while the previous data is transferred to the I/O buffers to be read.

Like all other 2-kB page NAND flash devices, a program operation typically writes 2 kbytes (x8) or 1 kword (x16) in 300 μ s and an erase operation can typically be performed in 3 ms (S34ML01G2) on a 128-kB block (x8) or 64k-word block (x16). In addition, thanks to multiplane architecture, it is possible to program two pages at a time (one per plane) or to erase two blocks at a time (again, one per plane). The multiplane architecture allows program time to be reduced by 40% and erase time to be reduced by 50%.

In multiplane operations, data in the page can be read out at 25 ns cycle time per byte. The I/O pins serve as the ports for command and address input as well as data input/output. This interface allows a reduced pin count and easy migration towards different densities, without any rearrangement of the footprint.

Commands, Data, and Addresses are asynchronously introduced using CE#, WE#, ALE, and CLE control pins.

The on-chip Program/Erase Controller automates all read, program, and erase functions including pulse repetition, where required, and internal verification and margining of data. A WP# pin is available to provide hardware protection against program and erase operations.

The output pin R/B# (open drain buffer) signals the status of the device during each operation. It identifies if the program/erase/read controller is currently active. The use of an open-drain output allows the Ready/Busy pins from several memories to connect to a single pull-up resistor. In a system with multiple memories the R/B# pins can be connected all together to provide a global status signal.

The Reprogram function allows the optimization of defective block management — when a Page Program operation fails the data can be directly programmed in another page inside the same array section without the time consuming serial data insertion phase.

Multiplane Copy Back is also supported. Data read out after Copy Back Read (both for single and multiplane cases) is allowed.

In addition, Cache Program and Multiplane Cache Program operations improve the programming throughput by programming data using the cache register.

The devices provide two innovative features: Page Reprogram and Multiplane Page Reprogram. The Page Reprogram re-programs one page. Normally, this operation is performed after a failed Page Program operation. Similarly, the Multiplane Page Reprogram re-programs two pages in parallel, one per plane. The first page must be in the first plane while the second page must be in the second plane. The Multiplane Page Reprogram operation is performed after a failed Multiplane Page Program operation. The Page Reprogram and Multiplane Page Reprogram guarantee improved performance, since data insertion can be omitted during re-program operations.

The devices are available in the TSOP48 (12 x 20 mm) package and come with the following security features:

- OTP (one time programmable) area, which is a restricted access area where sensitive data/code can be stored permanently.
- Serial number (unique identifier), which allows the devices to be uniquely identified. Contact factory for support of this feature.

These security features are subject to an NDA (non-disclosure agreement) and are, therefore, not described in the data sheet. For more details about them, contact your nearest sales office.

Device	Density (bits)		Number of Planes	Number of Blocks per Plane
	Main	Spare		
S34ML01G2	128M x 8	4M x 8	1	1024
	64M x 16	2M x 16		
S34ML02G2	256M x 8	16M x 8	2	1024
	128M x 16	8M x 16		
S34ML04G2	512M x 8	32M x 8	2	2048
	256M x 16	16M x 16		

1.1 Logic Diagram

Figure 1.1 Logic Diagram

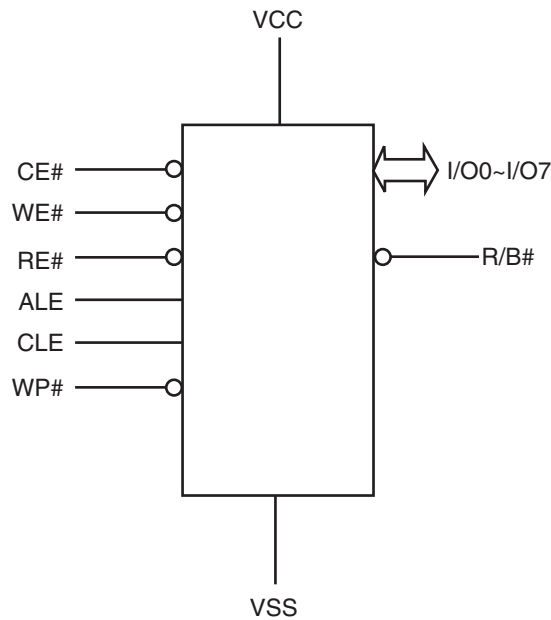
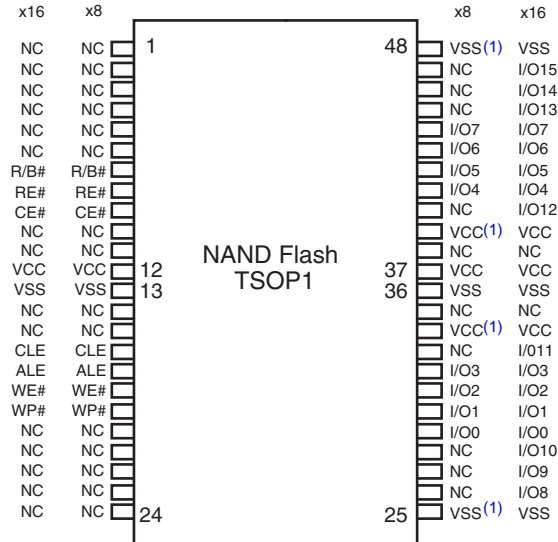

Table 1.1 Signal Names

I/O7 - I/O0 (x8)	Data Input / Outputs
I/O8 - I/O15 (x16)	
CLE	Command Latch Enable
ALE	Address Latch Enable
CE#	Chip Enable
RE#	Read Enable
WE#	Write Enable
WP#	Write Protect
R/B#	Read/Busy
VCC	Power Supply
VSS	Ground
NC	Not Connected

1.2 Connection Diagram

Figure 1.2 48-Pin TSOP1 Contact x8, x16 Device



Note:

1. These pins should be connected to power supply or ground (as designated) following the ONFI specification, however they might not be bonded internally.

Figure 1.3 63-BGA Contact, x8 Device (Balls Down, Top View)

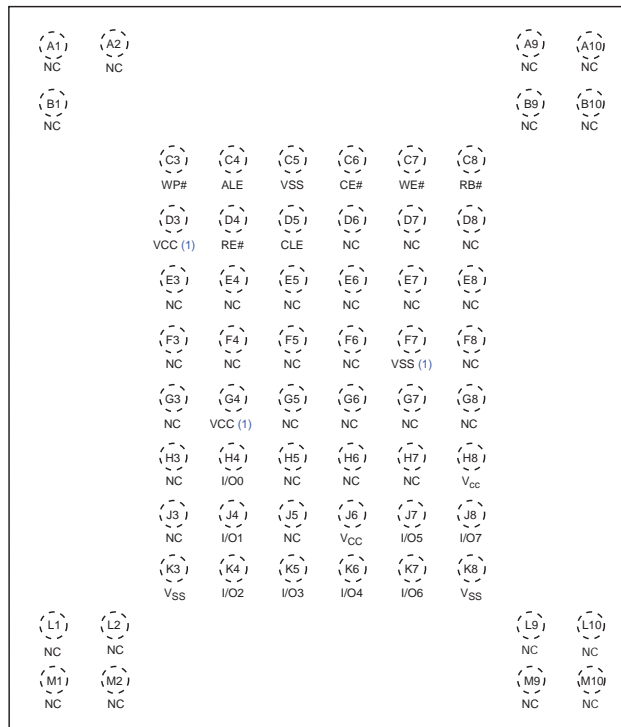

Note:

1. These pins should be connected to power supply or ground (as designated) following the ONFI specification, however they might not be bonded internally.

Figure 1.4 63-BGA Contact, x16 Device (Balls Down, Top View)

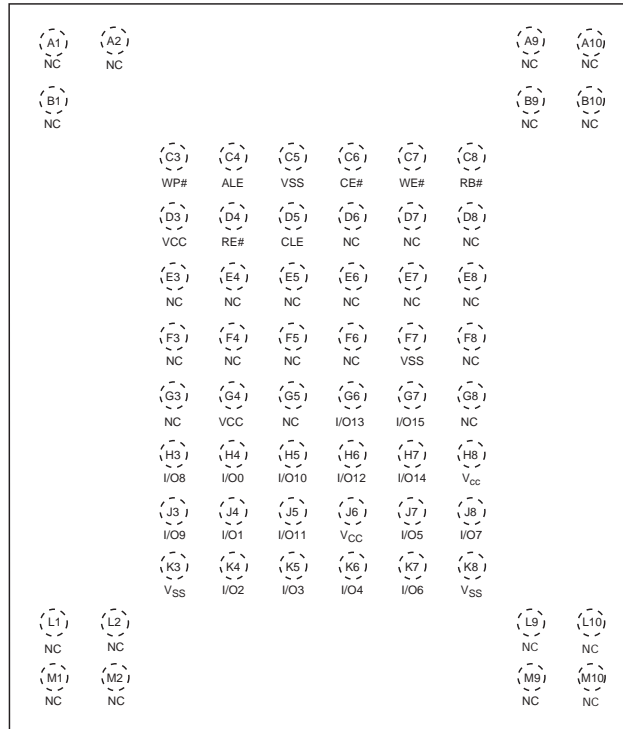
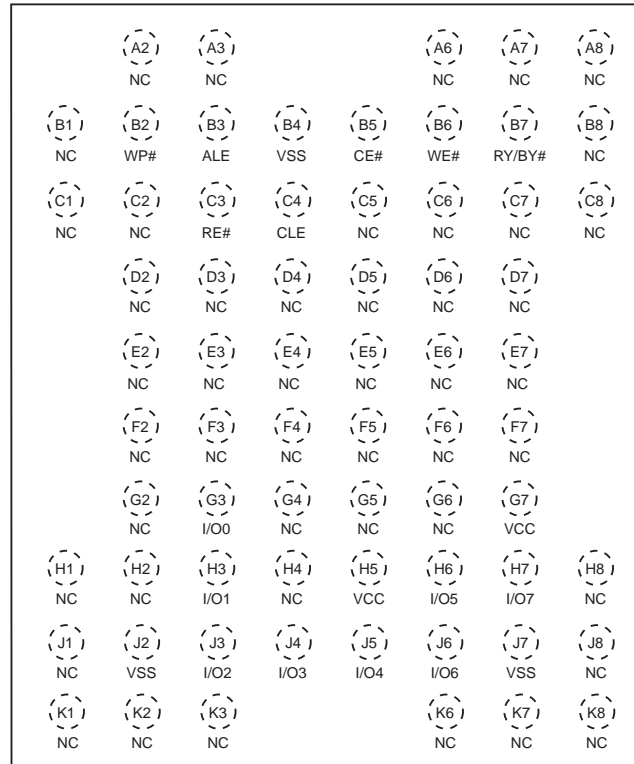

Figure 1.5 67-BGA Contact (Balls Down, Top View)



1.3 Pin Description

Table 1.2 Pin Description

Pin Name	Description
I/O0 - I/O7 (x8)	Inputs/Outputs. The I/O pins are used for command input, address input, data input, and data output. The I/O pins float to High-Z when the device is deselected or the outputs are disabled.
I/O8 - I/O15 (x16)	
CLE	Command Latch Enable. This input activates the latching of the I/O inputs inside the Command Register on the rising edge of Write Enable (WE#).
ALE	Address Latch Enable. This input activates the latching of the I/O inputs inside the Address Register on the rising edge of Write Enable (WE#).
CE#	Chip Enable. This input controls the selection of the device. When the device is not busy CE# low selects the memory.
WE#	Write Enable. This input latches Command, Address and Data. The I/O inputs are latched on the rising edge of WE#.
RE#	Read Enable. The RE# input is the serial data-out control, and when active drives the data onto the I/O bus. Data is valid t_{REA} after the falling edge of RE# which also increments the internal column address counter by one.
WP#	Write Protect. The WP# pin, when low, provides hardware protection against undesired data modification (program / erase).
R/B#	Ready Busy. The Ready/Busy output is an Open Drain pin that signals the state of the memory.
VCC	Supply Voltage. The VCC supplies the power for all the operations (Read, Program, Erase). An internal lock circuit prevents the insertion of Commands when VCC is less than VLKO.
VSS	Ground.
NC	Not Connected.

Notes:

1. A 0.1 μ F capacitor should be connected between the VCC Supply Voltage pin and the VSS Ground pin to decouple the current surges from the power supply. The PCB track widths must be sufficient to carry the currents required during program and erase operations.
2. An internal voltage detector disables all functions whenever VCC is below 1.8V to protect the device from any involuntary program/erase during power transitions.

1.4 Block Diagram

Figure 1.6 Functional Block Diagram

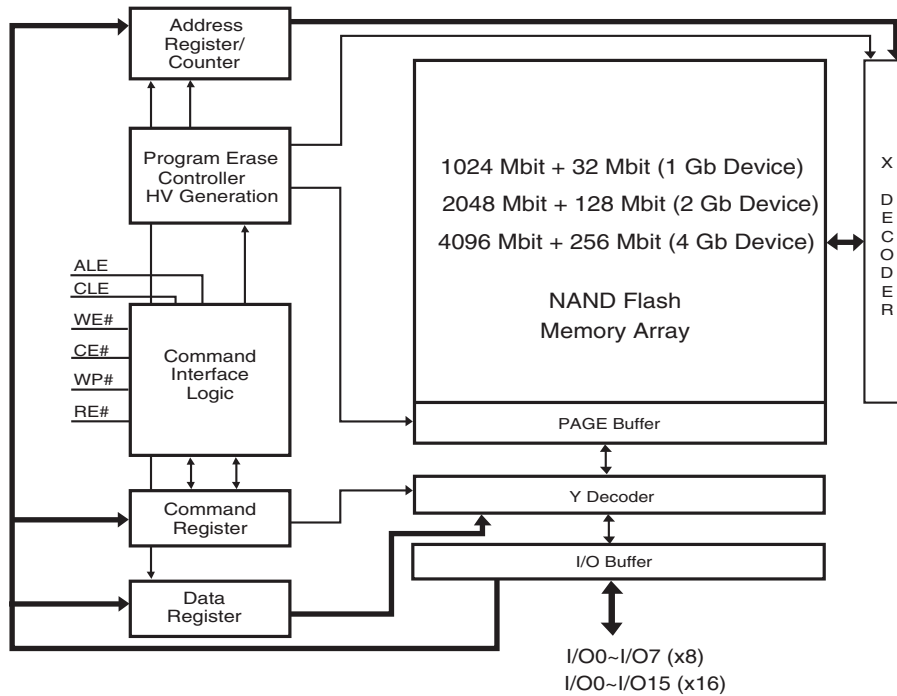

1.5 Array Organization

Figure 1.7 Array Organization — S34ML01G2 (x8)

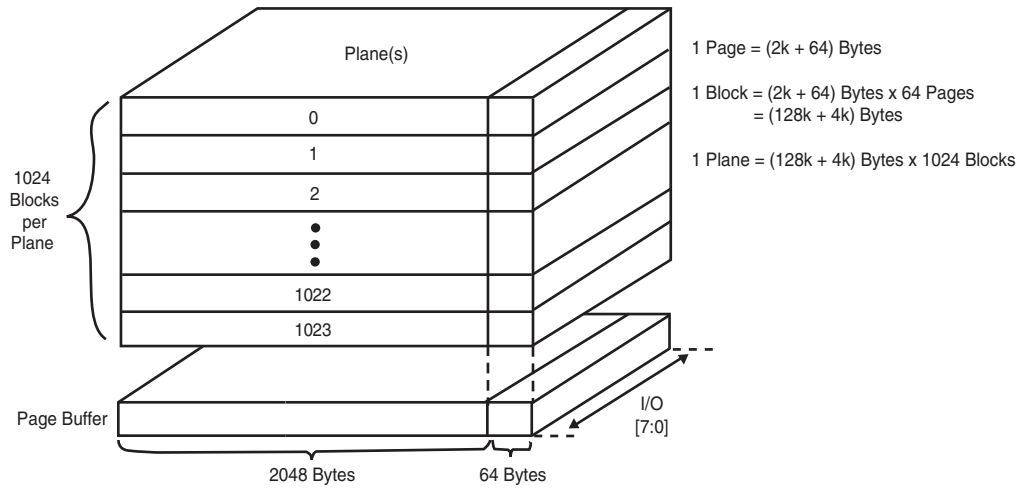

Array Organization (x8)

Figure 1.8 Array Organization — S34ML01G2 (x16)

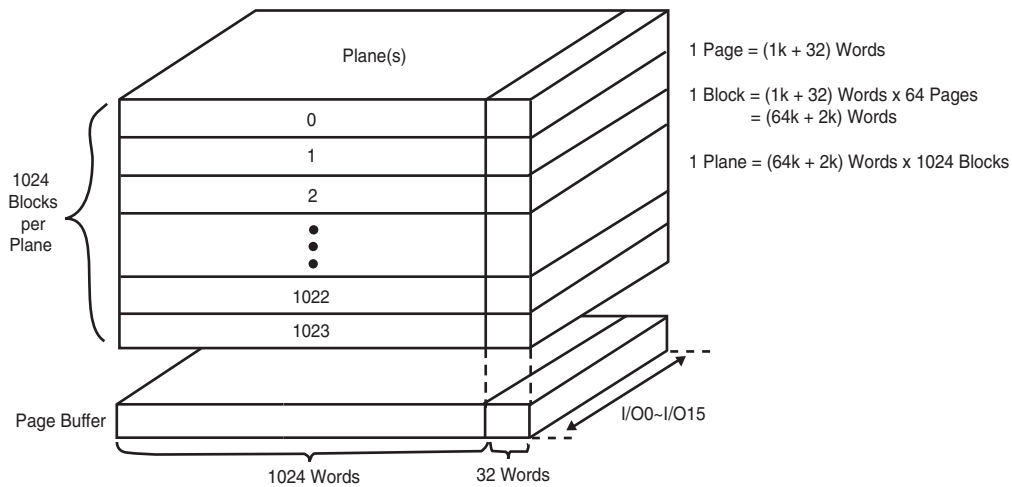

Array Organization (x16)

Figure 1.9 Array Organization — S34ML02G2 and S34ML04G2 (x8)

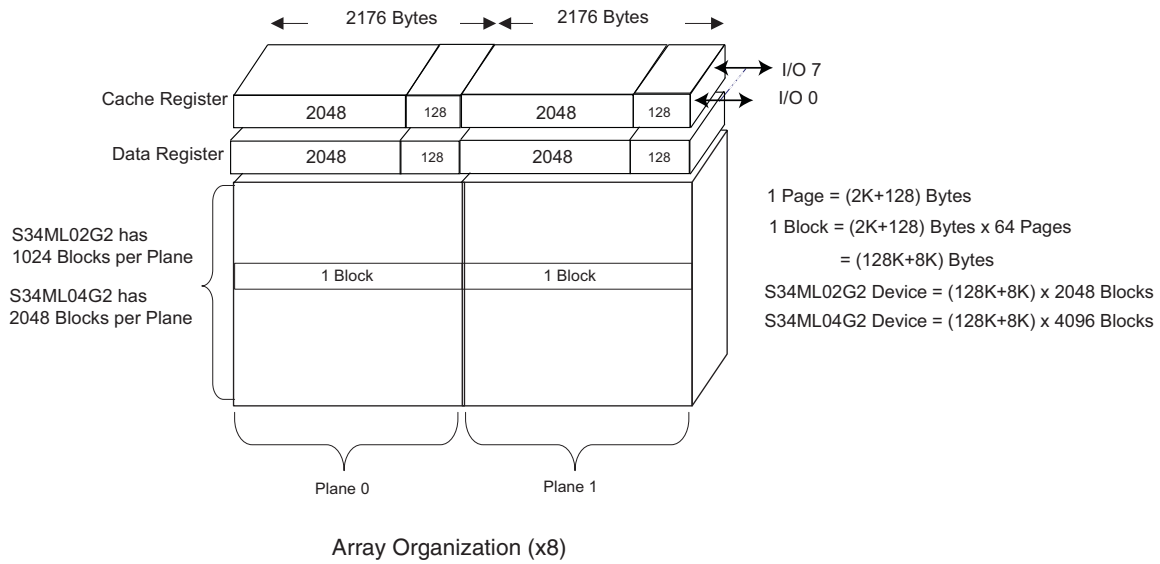
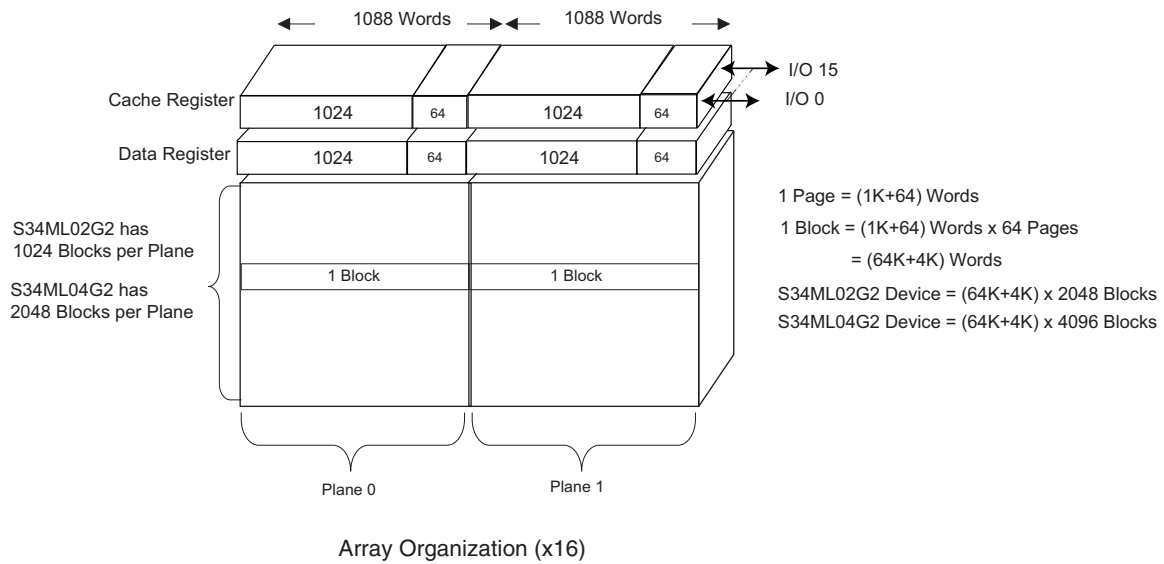

Figure 1.10 Array Organization — S34ML02G2 and S34ML04G2 (x16)



1.6 Addressing

1.6.1 S34ML01G2

Table 1.3 Address Cycle Map — 1 Gb Device

Bus Cycle	I/O [15:8] (5)	I/O0	I/O1	I/O2	I/O3	I/O4	I/O5	I/O6	I/O7
x8									
1st / Col. Add.1	—	A0 (CA0)	A1 (CA1)	A2 (CA2)	A3 (CA3)	A4 (CA4)	A5 (CA5)	A6 (CA6)	A7 (CA7)
2nd / Col. Add. 2	—	A8 (CA8)	A9 (CA9)	A10 (CA10)	A11 (CA11)	Low	Low	Low	Low
3rd / Row Add. 1	—	A12 (PA0)	A13 (PA1)	A14 (PA2)	A15 (PA3)	A16 (PA4)	A17 (PA5)	A18 (BA0)	A19 (BA1)
4th / Row Add. 2	—	A20 (BA2)	A21 (BA3)	A22 (BA4)	A23 (BA5)	A24 (BA6)	A25 (BA7)	A26 (BA8)	A27 (BA9)
x16									
1st / Col. Add.1	Low	A0 (CA0)	A1 (CA1)	A2 (CA2)	A3 (CA3)	A4 (CA4)	A5 (CA5)	A6 (CA6)	A7 (CA7)
2nd / Col. Add. 2	Low	A8 (CA8)	A9 (CA9)	A10 (CA10)	Low	Low	Low	Low	Low
3rd / Row Add. 1	Low	A11 (PA0)	A12 (PA1)	A13 (PA2)	A14 (PA3)	A15 (PA4)	A16 (PA5)	A17 (BA0)	A18 (BA1)
4th / Row Add. 2	Low	A19 (BA2)	A20 (BA3)	A21 (BA4)	A22 (BA5)	A23 (BA6)	A24 (BA7)	A25 (BA8)	A26 (BA9)

Notes:

1. CAx = Column Address bit.
2. PAx = Page Address bit.
3. BAx = Block Address bit.
4. Block address concatenated with page address = actual page address, also known as the row address.
5. I/O[15:8] are not used during the addressing sequence and should be driven Low.

For the x8 address bits, the following rules apply:

- A0 - A11: column address in the page
- A12 - A17: page address in the block
- A18 - A27: block address

For the x16 address bits, the following rules apply:

- A0 - A10: column address in the page
- A11 - A16: page address in the block
- A17 - A26: block address

1.6.2 S34ML02G2

Table 1.4 Address Cycle Map — 2 Gb Device

Bus Cycle	I/O [15:8] (6)	I/O0	I/O1	I/O2	I/O3	I/O4	I/O5	I/O6	I/O7
x8									
1st / Col. Add.1	—	A0 (CA0)	A1 (CA1)	A2 (CA2)	A3 (CA3)	A4 (CA4)	A5 (CA5)	A6 (CA6)	A7 (CA7)
2nd / Col. Add. 2	—	A8 (CA8)	A9 (CA9)	A10 (CA10)	A11 (CA11)	Low	Low	Low	Low
3rd / Row Add. 1	—	A12 (PA0)	A13 (PA1)	A14 (PA2)	A15 (PA3)	A16 (PA4)	A17 (PA5)	A18 (PLA0)	A19 (BA0)
4th / Row Add. 2	—	A20 (BA1)	A21 (BA2)	A22 (BA3)	A23 (BA4)	A24 (BA5)	A25 (BA6)	A26 (BA7)	A27 (BA8)
5th / Row Add. 3	—	A28 (BA9)	Low	Low	Low	Low	Low	Low	Low
x16									
1st / Col. Add.1	Low	A0 (CA0)	A1 (CA1)	A2 (CA2)	A3 (CA3)	A4 (CA4)	A5 (CA5)	A6 (CA6)	A7 (CA7)

Table 1.4 Address Cycle Map — 2 Gb Device

Bus Cycle	I/O [15:8] (6)	I/O0	I/O1	I/O2	I/O3	I/O4	I/O5	I/O6	I/O7
x8									
2nd / Col. Add. 2	Low	A8 (CA8)	A9 (CA9)	A10 (CA10)	Low	Low	Low	Low	Low
3rd / Row Add. 1	Low	A11 (PA0)	A12 (PA1)	A13 (PA2)	A14 (PA3)	A15 (PA4)	A16 (PA5)	A17 (PLA0)	A18 (BA0)
4th / Row Add. 2	Low	A19 (BA1)	A20 (BA2)	A21 (BA3)	A22 (BA4)	A23 (BA5)	A24 (BA6)	A25 (BA7)	A26 (BA8)
5th / Row Add. 3	Low	A27 (BA9)	Low	Low	Low	Low	Low	Low	Low

Notes:

1. CAx = Column Address bit.
2. PAx = Page Address bit.
3. PLA0 = Plane Address bit zero.
4. BAx = Block Address bit.
5. Block address concatenated with page address and plane address = actual page address, also known as the row address.
6. I/O[15:8] are not used during the addressing sequence and should be driven Low.

For the x8 address bits, the following rules apply:

- A0 - A11: column address in the page
- A12 - A17: page address in the block
- A18: plane address (for multiplane operations) / block address (for normal operations)
- A19 - A28: block address

For the x16 address bits, the following rules apply:

- A0 - A10: column address in the page
- A11 - A16: page address in the block
- A17: plane address (for multiplane operations) / block address (for normal operations)
- A18 - A27: block address

1.6.3 S34ML04G2

Table 1.5 Address Cycle Map — 4 Gb Device

Bus Cycle	I/O [15:8] (6)	I/O0	I/O1	I/O2	I/O3	I/O4	I/O5	I/O6	I/O7
x8									
1st / Col. Add.1	—	A0 (CA0)	A1 (CA1)	A2 (CA2)	A3 (CA3)	A4 (CA4)	A5 (CA5)	A6 (CA6)	A7 (CA7)
2nd / Col. Add. 2	—	A8 (CA8)	A9 (CA9)	A10 (CA10)	A11 (CA11)	Low	Low	Low	Low
3rd / Row Add. 1	—	A12 (PA0)	A13 (PA1)	A14 (PA2)	A15 (PA3)	A16 (PA4)	A17 (PA5)	A18 (PLA0)	A19 (BA0)
4th / Row Add. 2	—	A20 (BA1)	A21 (BA2)	A22 (BA3)	A23 (BA4)	A24 (BA5)	A25 (BA6)	A26 (BA7)	A27 (BA8)
5th / Row Add. 3	—	A28 (BA9)	A29 (BA10)	Low	Low	Low	Low	Low	Low
x16									
1st / Col. Add.1	Low	A0 (CA0)	A1 (CA1)	A2 (CA2)	A3 (CA3)	A4 (CA4)	A5 (CA5)	A6 (CA6)	A7 (CA7)
2nd / Col. Add. 2	Low	A8 (CA8)	A9 (CA9)	A10 (CA10)	Low	Low	Low	Low	Low
3rd / Row Add. 1	Low	A11 (PA0)	A12 (PA1)	A13 (PA2)	A14 (PA3)	A15 (PA4)	A16 (PA5)	A17 (PLA0)	A18 (BA0)
4th / Row Add. 2	Low	A19 (BA1)	A20 (BA2)	A21 (BA3)	A22 (BA4)	A23 (BA5)	A24 (BA6)	A25 (BA7)	A26 (BA8)
5th / Row Add. 3	Low	A27 (BA9)	A28 (BA10)	Low	Low	Low	Low	Low	Low

Notes:

1. *CAX* = Column Address bit.
2. *PAX* = Page Address bit.
3. *PLA0* = Plane Address bit zero.
4. *BAX* = Block Address bit.
5. Block address concatenated with page address and plane address = actual page address, also known as the row address.
6. *I/O[15:8]* are not used during the addressing sequence and should be driven Low.

For the x8 address bits, the following rules apply:

- A0 - A11: column address in the page
- A12 - A17: page address in the block
- A18: plane address (for multiplane operations) / block address (for normal operations)
- A19 - A29: block address

For the x16 address bits, the following rules apply:

- A0 - A10: column address in the page
- A11 - A16: page address in the block
- A17: plane address (for multiplane operations) / block address (for normal operations)
- A18 - A28: block address

1.7 Mode Selection

Table 1.6 Mode Selection

Mode		CLE	ALE	CE#	WE#	RE#	WP#
Read Mode	Command Input	High	Low	Low	Rising	High	X
	Address Input	Low	High	Low	Rising	High	X
Program or Erase Mode	Command Input	High	Low	Low	Rising	High	High
	Address Input	Low	High	Low	Rising	High	High
Data Input		Low	Low	Low	Rising	High	High
Data Output (on going)		Low	Low	Low	High	Falling	X
Data Output (suspended)		X	X	X	High	High	X
Busy Time in Read		X	X	X	High	High (3)	X
Busy Time in Program		X	X	X	X	X	High
Busy Time in Erase		X	X	X	X	X	High
Write Protect		X	X	X	X	X	Low
Stand By		X	X	High	X	X	0V / V _{CC} (2)

Notes:

1. X can be V_{IL} or V_{IH}. High = Logic level high, Low = Logic level low.
2. WP# should be biased to CMOS high or CMOS low for stand-by mode.
3. During Busy Time in Read, RE# must be held high to prevent unintended data out.

2. Bus Operation

There are six standard bus operations that control the device: Command Input, Address Input, Data Input, Data Output, Write Protect, and Standby. (See [Table 1.6](#).)

Typically glitches less than 5 ns on Chip Enable, Write Enable, and Read Enable are ignored by the memory and do not affect bus operations.

2.1 Command Input

The Command Input bus operation is used to give a command to the memory device. Commands are accepted with Chip Enable low, Command Latch Enable high, Address Latch Enable low, and Read Enable high and latched on the rising edge of Write Enable. Moreover, for commands that start a modify operation (program/erase) the Write Protect pin must be high. See [Figure 6.1 on page 39](#) and [Table 5.5 on page 36](#) for details of the timing requirements. Command codes are always applied on I/O7:0 regardless of the bus configuration (x8 or x16).

2.2 Address Input

The Address Input bus operation allows the insertion of the memory address. For the S34ML02G2 and S34ML04G2 devices, five write cycles are needed to input the addresses. For the S34ML01G2, four write cycles are needed to input the addresses. If necessary, a 5th dummy address cycle can be issued to S34ML01G2, which will be ignored by the NAND device without causing problems. Addresses are accepted with Chip Enable low, Address Latch Enable high, Command Latch Enable low, and Read Enable high and latched on the rising edge of Write Enable. Moreover, for commands that start a modify operation (program/erase) the Write Protect pin must be high. See [Figure 6.2 on page 40](#) and [Table 5.5 on page 36](#) for details of the timing requirements. Addresses are always applied on I/O7:0 regardless of the bus configuration (x8 or x16). Refer to [Table 1.3](#) through [Table 1.5 on page 12](#) for more detailed information.

2.3 Data Input

The Data Input bus operation allows the data to be programmed to be sent to the device. The data insertion is serial and timed by the Write Enable cycles. Data is accepted only with Chip Enable low, Address Latch Enable low, Command Latch Enable low, Read Enable high, and Write Protect high and latched on the rising edge of Write Enable. See [Figure 6.3 on page 41](#) and [Table 5.5 on page 36](#) for details of the timing requirements.

2.4 Data Output

The Data Output bus operation allows data to be read from the memory array and to check the Status Register content, and the ID data. Data can be serially shifted out by toggling the Read Enable pin with Chip Enable low, Write Enable high, Address Latch Enable low, and Command Latch Enable low. See [Figure 6.4 on page 41](#) and [Table 5.5 on page 36](#) for details of the timings requirements.

2.5 Write Protect

The Hardware Write Protection is activated when the Write Protect pin is low. In this condition, modify operations do not start and the content of the memory is not altered. The Write Protect pin is not latched by Write Enable to ensure the protection even during power up.

2.6 Standby

In Standby, the device is deselected, outputs are disabled, and power consumption is reduced.

3. Command Set

Table 3.1 Command Set

Command	1st Cycle	2nd Cycle	3rd Cycle	4th Cycle	Acceptable Command during Busy	Supported on S34ML01G2
Page Read	00h	30h			No	Yes
Page Program	80h	10h			No	Yes
Random Data Input	85h				No	Yes
Random Data Output	05h	E0h			No	Yes
Multiplane Program	80h	11h	81h	10h	No	No
ONFI Multiplane Program	80h	11h	80h	10h	No	No
Page Reprogram	8Bh	10h			No	Yes
Multiplane Page Reprogram	8Bh	11h	8Bh	10h	No	No
Block Erase	60h	D0h			No	Yes
Multiplane Block Erase	60h	60h	D0h		No	No
ONFI Multiplane Block Erase	60h	D1h	60h	D0h	No	No
Copy Back Read	00h	35h			No	Yes
Copy Back Program	85h	10h			No	Yes
Multiplane Copy Back Program	85h	11h	81h	10h	No	No
ONFI Multiplane Copy Back Program	85h	11h	85h	10h	No	No
Special Read For Copy Back	00h	36h			No	No
Read Status Register	70h				Yes	Yes
Read Status Enhanced	78h				Yes	No
Reset	FFh				Yes	Yes
Read Cache	31h				No	Yes
Read Cache Enhanced	00h	31h			No	Yes
Read Cache End	3Fh				No	Yes
Cache Program (End)	80h	10h			No	Yes
Cache Program (Start) / (Continue)	80h	15h			No	Yes
Multiplane Cache Program (Start/Continue)	80h	11h	81h	15h	No	No
ONFI Multiplane Cache Program (Start/Continue)	80h	11h	80h	15h	No	No
Multiplane Cache Program (End)	80h	11h	81h	10h	No	No
ONFI Multiplane Cache Program (End)	80h	11h	80h	10h	No	No
Read ID	90h				No	Yes
Read ID2	30h-65h-00h	30h			No	Yes
Read ONFI Signature	90h				No	Yes
Read Parameter Page	ECh				No	Yes
Read Unique ID (Contact Factory)	EDh				No	Yes
One-time Programmable (OTP) Area Entry	29h-17h-04h-19h				No	Yes

3.1 Page Read

Page Read is initiated by writing 00h and 30h to the command register along with five address cycles (four or five cycles for S34ML01G2). Two types of operations are available: random read and serial page read. Random read mode is enabled when the page address is changed. All data within the selected page are transferred to the data registers. The system controller may detect the completion of this data transfer (t_R) by analyzing the output of the R/B pin. Once the data in a page is loaded into the data registers, they may be read out in 25 ns cycle time by sequentially pulsing RE#. The repetitive high to low transitions of the RE# signal makes the device output the data, starting from the selected column address up to the last column address.

The device may output random data in a page instead of the sequential data by writing Random Data Output command. The column address of next data, which is going to be out, may be changed to the address that follows Random Data Output command. Random Data Output can be performed as many times as needed.

After power up, the device is in read mode, so 00h command cycle is not necessary to start a read operation. Any operation other than read or Random Data Output causes the device to exit read mode.

See [Figure 6.6 on page 42](#) and [Figure 6.12 on page 46](#) as references.

3.2 Page Program

A page program cycle consists of a serial data loading period in which up to 2 kbytes (x8) or 1 kword (x16) of data may be loaded into the data register, followed by a non-volatile programming period where the loaded data is programmed into the appropriate cell.

The serial data loading period begins by inputting the Serial Data Input command (80h), followed by the five cycle address inputs (four cycles for S34ML01G2) and then serial data. The words other than those to be programmed do not need to be loaded. The device supports Random Data Input within a page. The column address of next data, which will be entered, may be changed to the address that follows the Random Data Input command (85h). Random Data Input may be performed as many times as needed.

The Page Program confirm command (10h) initiates the programming process. The internal write state controller automatically executes the algorithms and controls timings necessary for program and verify, thereby freeing the system controller for other tasks.

Once the program process starts, the Read Status Register commands (70h or 78h) may be issued to read the Status Register. The system controller can detect the completion of a program cycle by monitoring the

R/B# output, or the Status bit (I/O6) of the Status Register. Only the Read Status commands (70h or 78h) or Reset command are valid while programming is in progress. When the Page Program is complete, the Write Status Bit (I/O0) may be checked. The internal write verify detects only errors for 1's that are not successfully programmed to 0's. The command register remains in Read Status command mode until another valid command is written to the command register. [Figure 6.9 on page 44](#) and [Figure 6.11 on page 45](#) detail the sequence.

The device is programmable by page, but it also allows multiple partial page programming of a word or consecutive bytes up to 2 kbytes (x8) or 1 kword (x16) in a single page program cycle.

The number of consecutive partial page programming operations (NOP) within the same page must not exceed the number indicated in [Table 5.8 on page 38](#). Pages may be programmed in any order within a block.

If a Page Program operation is interrupted by hardware reset, power failure or other means, the host must ensure that the interrupted page is not used for further reading or programming operations until the next uninterrupted block erase is complete.

3.3 Multiplane Program — S34ML02G2 and S34ML04G2

The S34ML02G2 and S34ML04G2 devices support Multiplane Program, making it possible to program two pages in parallel, one page per plane.

A Multiplane Program cycle consists of a double serial data loading period in which up to 4352 bytes (x8) or 2176 words (x16) of data may be loaded into the data register, followed by a non-volatile programming period where the loaded data is programmed into the appropriate cell. The serial data loading period begins with inputting the Serial Data Input command (80h), followed by the five cycle address inputs and serial data for the 1st page. The address for this page must be in the 1st plane (PLA0 = 0). The device supports Random Data Input exactly the same as in the case of page program operation. The Dummy Page Program Confirm command (11h) stops 1st page data input and the device becomes busy for a short time (t_{DBSY}). Once it has become ready again, the '81h' command must be issued, followed by 2nd page address (5 cycles) and its serial data input. The address for this page must be in the 2nd plane (PLA0 = 1). The Program Confirm command (10h) starts parallel programming of both pages.

[Figure 6.13 on page 46](#) describes the sequences using the legacy protocol. In this case, the block address bits for the first plane are all zero and the second address issued selects the block for both planes. [Figure 6.14 on page 47](#) describes the sequences using the ONFI protocol. For both addresses issued in this protocol, the block address bits must be the same except for the bit(s) that select the plane.

The user can check operation status by monitoring R/B# pin or reading the Status Register (command 70h or 78h). The Read Status Register command is also available during Dummy Busy time (t_{DBSY}). In case of failure in either page program, the fail bit of the Status Register will be set. Refer to [Section 3.8 on page 22](#) for further info.

The number of consecutive partial page programming operations (NOP) within the same page must not exceed the number indicated in [Table 5.8 on page 38](#). Pages may be programmed in any order within a block.

If a Multiplane Program operation is interrupted by hardware reset, power failure or other means, the host must ensure that the interrupted pages are not used for further reading or programming operations until the next uninterrupted block erases are complete for the applicable blocks.

3.4 Page Reprogram

Page Program may result in a fail, which can be detected by Read Status Register. In this event, the host may call Page Reprogram. This command allows the reprogramming of the same pattern of the last (failed) page into another memory location. The command sequence initiates with reprogram setup (8Bh), followed by the five cycle address inputs of the target page. If the target pattern for the destination page is not changed compared to the last page, the program confirm can be issued (10h) without any data input cycle, as described in [Figure 3.1](#).

Figure 3.1 Page Reprogram

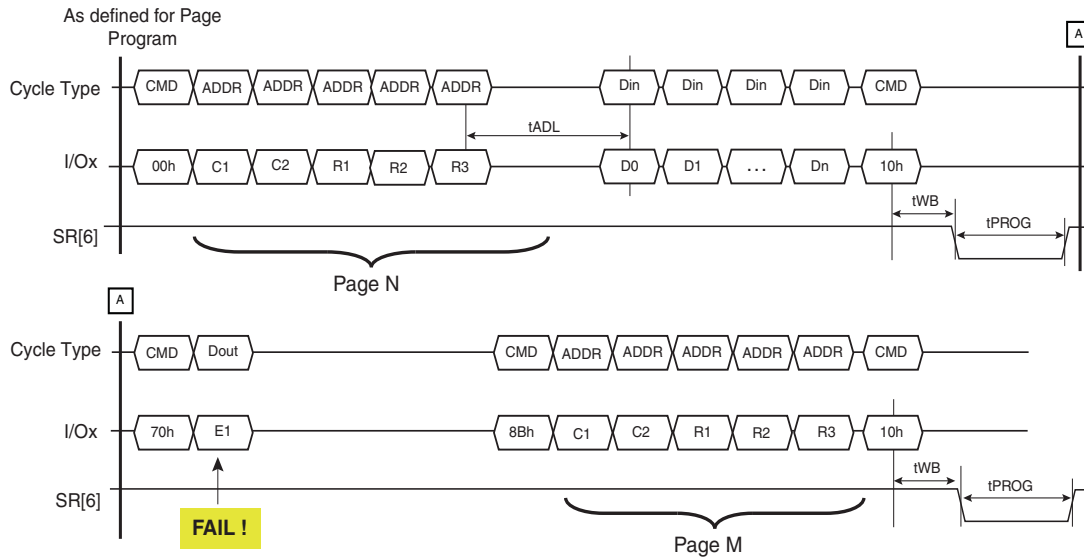

On the other hand, if the pattern bound for the target page is different from that of the previous page, data in cycles can be issued before program confirm '10h', as described in [Figure 3.2](#).

Figure 3.2 Page Reprogram with Data Manipulation

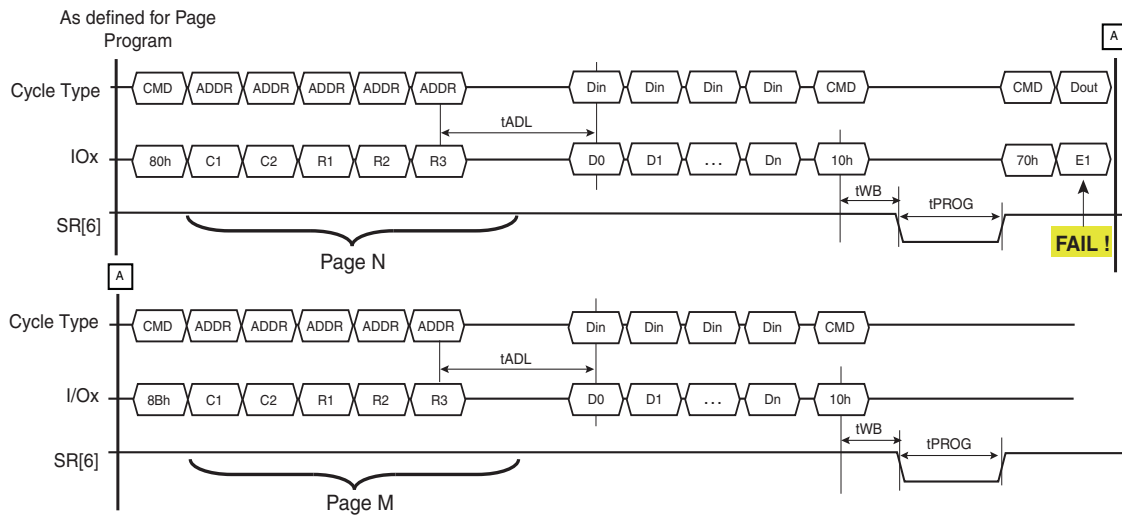

The device supports Random Data Input within a page. The column address of next data, which will be entered, may be changed to the address which follows the Random Data Input command (85h). Random Data Input may be operated multiple times regardless of how many times it is done in a page.

The Program Confirm command (10h) initiates the re-programming process. The internal write state controller automatically executes the algorithms and controls timings necessary for program and verify, thereby freeing the system controller for other tasks. Once the program process starts, the Read Status Register command may be issued to read the Status Register. The system controller can detect the completion of a program cycle by monitoring the R/B# output, or the Status bit (I/O6) of the Status Register. Only the Read Status command and Reset command are valid when programming is in progress. When the Page Program is

complete, the Write Status Bit (I/O0) may be checked. The internal write verify detects only errors for 1's that are not successfully programmed to 0's. The command register remains in Read Status command mode until another valid command is written to the command register.

The Page Reprogram must be issued in the same plane as the Page Program that failed. In order to program the data to a different plane, use the Page Program operation instead. The Multiplane Page Reprogram can re-program two pages in parallel, one per plane. The Multiplane Page Reprogram operation is performed after a failed Multiplane Page Program operation. The command sequence is very similar to [Figure 6.13, Multiplane Page Program on page 46](#), except that it requires the Page Reprogram Command (8Bh) instead of 80h and 81h.

If a Page Reprogram operation is interrupted by hardware reset, power failure or other means, the host must ensure that the interrupted page is not used for further reading or programming operations until the next uninterrupted block erase is complete.

3.5 Block Erase

The Block Erase operation is done on a block basis. Block address loading is accomplished in three cycles (two cycles for S34ML01G2) initiated by an Erase Setup command (60h). Only the block address bits are valid while the page address bits are ignored.

The Erase Confirm command (D0h) following the block address loading initiates the internal erasing process. This two-step sequence of setup followed by the execution command ensures that memory contents are not accidentally erased due to external noise conditions.

At the rising edge of WE# after the erase confirm command input, the internal write controller handles erase and erase verify. Once the erase process starts, the Read Status Register commands (70h or 78h) may be issued to read the Status Register.

The system controller can detect the completion of an erase by monitoring the R/B# output, or the Status bit (I/O6) of the Status Register. Only the Read Status commands (70h or 78h) and Reset command are valid while erasing is in progress. When the erase operation is completed, the Write Status Bit (I/O0) may be checked. [Figure 6.15 on page 47](#) details the sequence.

If a Block Erase operation is interrupted by hardware reset, power failure or other means, the host must ensure that the interrupted block is erased under continuous power conditions before that block can be trusted for further programming and reading operations.

3.6 Multiplane Block Erase — S34ML02G2 and S34ML04G2

Multiplane Block Erase allows the erase of two blocks in parallel, one block per memory plane.

The Block erase setup command (60h) must be repeated two times, followed by 1st and 2nd block address respectively (3 cycles each). As for block erase, D0h command makes embedded operation start. In this case, multiplane erase does not need any Dummy Busy Time between 1st and 2nd block insertion. See [Table 5.8 on page 38](#) for performance information.

For the Multiplane Block Erase operation, the address of the first block must be within the first plane (PLA0 = 0) and the address of the second block in the second plane (PLA0 = 1). See [Figure 6.16 on page 48](#) for a description of the legacy protocol. In this case, the block address bits for the first plane are all zero and the second address issued selects the block for both planes. [Figure 6.17 on page 48](#) describes the sequences using the ONFI protocol. For both addresses issued in this protocol, the block address bits must be the same except for the bit(s) that select the plane.

The user can check operation status by monitoring R/B# pin or reading the Status Register (command 70h or 78h). The Read Status Register command is also available during Dummy Busy time (t_{DBSY}). In case of failure in either erase, the fail bit of the Status Register will be set. Refer to [Section 3.7.2 on page 21](#) for further information.

If a Multiplane Block Erase operation is interrupted by hardware reset, power failure or other means, the host must ensure that the interrupted blocks are erased under continuous power conditions before those blocks can be trusted for further programming and reading operations.

3.7 Copy Back Program

The copy back feature is intended to quickly and efficiently rewrite data stored in one page without utilizing an external memory. Since the time-consuming cycles of serial access and re-loading cycles are removed, the system performance is greatly improved. The benefit is especially obvious when a portion of a block needs to be updated and the rest of the block also needs to be copied to the newly assigned free block. The operation for performing a copy back is a sequential execution of page-read (without mandatory serial access) and Copy Back Program with the address of destination page. A read operation with the '35h' command and the address of the source page moves the whole page of data into the internal data register. As soon as the device returns to the Ready state, optional data read-out is allowed by toggling RE# (see [Figure 6.18 on page 49](#)), or the Copy Back Program command (85h) with the address cycles of the destination page may be written. The Program Confirm command (10h) is required to actually begin programming.

The source and the destination pages in the Copy Back Program sequence must belong to the same device plane (same PLA0 for S34ML02G2 and S34ML04G2). Copy Back Read and Copy Back Program for a given plane must be between odd address pages or between even address pages for the device to meet the program time (t_{PROG}) specification. Copy Back Program may not meet this specification when copying from an odd address page (source page) to an even address page (target page) or from an even address page (source page) to an odd address page (target page).

The data input cycle for modifying a portion or multiple distinct portions of the source page is allowed as shown in [Figure 6.19 on page 49](#).

If a Copy Back Program operation is interrupted by hardware reset, power failure or other means, the host must ensure that the interrupted page is not used for further reading or programming operations until the next uninterrupted block erase is complete.

3.7.1 Multiplane Copy Back Program — S34ML02G2 and S34ML04G2

The device supports Multiplane Copy Back Program with exactly the same sequence and limitations as the Page Program. Multiplane Copy Back Program must be preceded by two single page Copy Back Read command sequences (1st page must be read from the 1st plane and 2nd page from the 2nd plane).

Multiplane Copy Back cannot cross plane boundaries — the contents of the source page of one device plane can be copied only to a destination page of the same plane.

The Multiplane Copy Back Program sequence represented in [Figure 6.20 on page 50](#) shows the legacy protocol. In this case, the block address bits for the first plane are all zero and the second address issued selects the block for both planes. [Figure 6.21 on page 51](#) describes the sequence using the ONFI protocol. For both addresses issued in this protocol, the block address bits must be the same except for the bit(s) that select the plane.

If a Multiplane Copy Back Program operation is interrupted by hardware reset, power failure or other means, the host must ensure that the interrupted pages are not used for further reading or programming operations until the next uninterrupted block erases are complete for the applicable blocks.

3.7.2 Special Read for Copy Back — S34ML02G2 and S34ML04G2

The S34ML02G2 and S34ML04G2 devices support Special Read for Copy Back. If Copy Back Read (described in [Section 3.7](#) and [Section 3.7.1 on page 21](#)) is triggered with confirm command '36h' instead '35h', Copy Back Read from target page(s) will be executed with an increased internal (V_{PASS}) voltage.

This special feature is used in order to minimize the number of read errors due to over-program or read disturb — it shall be used only if ECC read errors have occurred in the source page using Page Read or Copy Back Read sequences.

Excluding the Copy Back Read confirm command, all other features described in [Section 3.7](#) and [Section 3.7.1](#) for standard copy back remain valid (including the figures referred to in those sections).

3.8 Read Status Register

The Status Register is used to retrieve the status value for the last operation issued. After writing 70h command to the command register, a read cycle outputs the content of the Status Register to the I/O pins on the falling edge of CE# or RE#, whichever occurs last. This two-line control allows the system to poll the progress of each device in multiple memory connections even when R/B# pins are common-wired. Refer to [Section 3.2 on page 23](#) for specific Status Register definition, and to [Figure 6.22 on page 51](#) for timings.

If the Read Status Register command is issued during multiplane operations then Status Register polling will return the combined status value related to the outcome of the operation in the two planes according to the following table:

Status Register Bit	Composite Status Value
Bit 0, Pass/Fail	OR
Bit 1, Cache Pass/Fail	OR

In other words, the Status Register is dynamic; the user is not required to toggle RE# / CE# to update it.

The command register remains in Status Read mode until further commands are issued. Therefore, if the Status Register is read during a random read cycle, the read command (00h) must be issued before starting read cycles.

Note: The Read Status Register command shall not be used for concurrent operations in multi-die stack configurations (single CE#). “Read Status Enhanced” shall be used instead.

3.9 Read Status Enhanced — S34ML02G2 and S34ML04G2

Read Status Enhanced is used to retrieve the status value for a previous operation in the specified plane.

[Figure 6.23 on page 52](#) defines the Read Status Enhanced behavior and timings. The plane and die address must be specified in the command sequence in order to retrieve the status of the die and the plane of interest.

Refer to [Table 3.2](#) for specific Status Register definitions. The command register remains in Status Read mode until further commands are issued.

The Status Register is dynamic; the user is not required to toggle RE# / CE# to update it.

3.10 Read Status Register Field Definition

[Table 3.2](#) below lists the meaning of each bit of the Read Status Register and Read Status Enhanced (S34ML02G2 and S34ML04G2).

Table 3.2 Status Register Coding

ID	Page Program / Page Reprogram	Block Erase	Read	Read Cache	Cache Program / Cache Reprogram	Coding
0	Pass / Fail	Pass / Fail	NA	NA	Pass / Fail	N Page Pass: 0 Fail: 1
1	NA	NA	NA	NA	Pass / Fail	N - 1 Page Pass: 0 Fail: 1
2	NA	NA	NA	NA	NA	—
3	NA	NA	NA	NA	NA	—
4	NA	NA	NA	NA	NA	—
5	Ready / Busy	Ready / Busy	Ready / Busy	Ready / Busy	Ready / Busy	Internal Data Operation Active: 0 Idle: 1
6	Ready / Busy	Ready / Busy	Ready / Busy	Ready / Busy	Ready / Busy	Ready / Busy Busy: 0 Ready: 1
7	Write Protect	Write Protect	NA	NA	Write Protect	Protected: 0 Not Protected: 1

3.11 Reset

The Reset feature is executed by writing FFh to the command register. If the device is in the Busy state during random read, program, or erase mode, the Reset operation will abort these operations. The contents of memory cells being altered are no longer valid, as the data may be partially programmed or erased. The command register is cleared to wait for the next command, and the Status Register is cleared to value E0h when WP# is high or value 60h when WP# is low. If the device is already in reset state a new Reset command will not be accepted by the command register. The R/B# pin transitions to low for t_{RST} after the Reset command is written. Refer to [Figure 6.24 on page 52](#) for further details. The Status Register can also be read to determine the status of a Reset operation.

3.12 Read Cache

Read Cache can be used to increase the read operation speed, as defined in [Section 3.1 on page 17](#), and it cannot cross a block boundary. As soon as the user starts to read one page, the device automatically loads the next page into the cache register. Serial data output may be executed while data in the memory is read into the cache register. Read Cache is initiated by the Page Read sequence (00-30h) on a page M.

After random access to the first page is complete (R/B# returned to high, or Read Status Register I/O6 switches to high), two command sequences can be used to continue read cache:

- Read Cache (command '31h' only): once the command is latched into the command register (see [Figure 6.26 on page 53](#)), device goes busy for a short time (t_{CBSYR}), during which data of the first page is transferred from the data register to the cache register. At the end of this phase, the cache register data can be output by toggling RE# while the next page (page address M+1) is read from the memory array into the data register.
- Read Cache Enhanced (sequence '00h' <page N address> '31'): once the command is latched into the command register (see [Figure 6.27 on page 54](#)), device goes busy for a short time (t_{CBSYR}), during which data of the first page is transferred from the data register to the cache register. At the end of this phase, cache register data can be output by toggling RE# while page N is read from the memory array into the data register.

Subsequent pages are read by issuing additional Read Cache or Read Cache Enhanced command sequences. If serial data output time of one page exceeds random access time (t_R), the random access time of the next page is hidden by data downloading of the previous page.

On the other hand, if 31h is issued prior to completing the random access to the next page, the device will stay busy as long as needed to complete random access to this page, transfer its contents into the cache register, and trigger the random access to the following page.

To terminate the Read Cache operation, 3Fh command should be issued (see [Figure 6.28 on page 54](#)). This command transfers data from the data register to the cache register without issuing next page read.

During the Read Cache operation, the device doesn't allow any other command except for 00h, 31h, 3Fh, Read SR, or Reset (FFh). To carry out other operations, Read Cache must be terminated by the Read Cache End command (3Fh) or the device must be reset by issuing FFh.

Read Status command (70h) may be issued to check the status of the different registers and the busy/ready status of the cached read operations.

- The Cache-Busy status bit I/O6 indicates when the cache register is ready to output new data.
- The status bit I/O5 can be used to determine when the cell reading of the current data register contents is complete.

Note: The Read Cache and Read Cache End commands reset the column counter, thus, when RE# is toggled to output the data of a given page, the first output data is related to the first byte of the page (column address 00h). Random Data Output command can be used to switch column address.

3.13 Cache Program

Cache Program can improve the program throughput by using the cache register. The Cache Program operation cannot cross a block boundary. The cache register allows new data to be input while the previous data that was transferred to the data register is programmed into the memory array.

After the serial data input command (80h) is loaded to the command register, followed by five cycles of address, a full or partial page of data is latched into the cache register.

Once the cache write command (15h) is loaded to the command register, the data in the cache register is transferred into the data register for cell programming. At this time the device remains in the Busy state for a short time (t_{CBSYW}). After all data of the cache register is transferred into the data register, the device returns to the Ready state and allows loading the next data into the cache register through another Cache Program command sequence (80h-15h).

The Busy time following the first sequence 80h - 15h equals the time needed to transfer the data from the cache register to the data register. Cell programming the data of the data register and loading of the next data into the cache register is consequently processed through a pipeline model.

In case of any subsequent sequence 80h - 15h, transfer from the cache register to the data register is held off until cell programming of current data register contents is complete; till this moment the device will stay in a busy state (t_{CBSYW}).

Read Status commands (70h or 78h) may be issued to check the status of the different registers, and the pass/fail status of the cached program operations.

- The Cache-Busy status bit I/O6 indicates when the cache register is ready to accept new data.
- The status bit I/O5 can be used to determine when the cell programming of the current data register contents is complete.
- The Cache Program error bit I/O1 can be used to identify if the previous page (page N-1) has been successfully programmed or not in a Cache Program operation. The status bit is valid upon I/O6 status bit changing to 1.
- The error bit I/O0 is used to identify if any error has been detected by the program/erase controller while programming page N. The status bit is valid upon I/O5 status bit changing to 1.

I/O1 may be read together with I/O0.

If the system monitors the progress of the operation only with R/B#, the last page of the target program sequence must be programmed with Page Program Confirm command (10h). If the Cache Program command (15h) is used instead, the status bit I/O5 must be polled to find out if the last programming is finished before starting any other operation. See [Table 3.2 on page 23](#) and [Figure 6.29 on page 55](#) for more details.

If a Cache Program operation is interrupted by hardware reset, power failure or other means, the host must ensure that the interrupted pages are not used for further reading or programming operations until the next uninterrupted block erases are complete for the applicable blocks.

3.14 Multiplane Cache Program — S34ML02G2 and S34ML04G2

The Multiplane Cache Program enables high program throughput by programming two pages in parallel, while exploiting the data and cache registers of both planes to implement cache.

The command sequence can be summarized as follows:

- Serial Data Input command (80h), followed by the five cycle address inputs and then serial data for the 1st page. Address for this page must be within 1st plane (PLA0 = 0). The data of 1st page other than those to be programmed do not need to be loaded. The device supports Random Data Input exactly like Page Program operation.
- The Dummy Page Program Confirm command (11h) stops 1st page data input and the device becomes busy for a short time (t_{DBSY}).
- Once device returns to ready again, 81h command must be issued, followed by 2nd page address (5 cycles) and its serial data input. Address for this page must be within 2nd plane (PLA0 = 1). The data of 2nd page other than those to be programmed do not need to be loaded.
- Cache Program confirm command (15h). Once the cache write command (15h) is loaded to the command register, the data in the cache registers is transferred into the data registers for cell programming. At this time the device remains in the Busy state for a short time (t_{CBSYW}). After all data from the cache registers are transferred into the data registers, the device returns to the Ready state, and allows loading the next data into the cache register through another Cache Program command sequence.

The sequence 80h...- 11h...-...81h...-...15h can be iterated, and each time the device will be busy for the t_{CBSYW} time needed to complete programming the current data register contents, and transferring the new data from the cache registers. The sequence to end Multiplane Cache Program is 80h...- 11h...-...81h...-...10h.

The Multiplane Cache Program is available only within two paired blocks in separate planes. [Figure 6.30 on page 56](#) shows the legacy protocol for the Multiplane Cache Program operation. In this case, the block address bits for the first plane are all zero and the second address issued selects the block for both planes. [Figure 6.31 on page 57](#) shows the ONFI protocol for the Multiplane Cache Program operation. For both addresses issued in this protocol, the block address bits must be the same except for the bit(s) that select the plane.

The user can check operation status by R/B# pin or Read Status Register commands (70h or 78h). If the user opts for 70h, Read Status Register will provide “global” information about the operation in the two planes.

- I/O6 indicates when both cache registers are ready to accept new data.
- I/O5 indicates when the cell programming of the current data registers is complete.
- I/O1 identifies if the previous pages in both planes (pages N-1) have been successfully programmed or not. This status bit is valid upon I/O6 status bit changing to 1.
- I/O0 identifies if any error has been detected by the program/erase controller while programming the two pages N. This status bit is valid upon I/O5 status bit changing to 1.

See [Table 3.2 on page 23](#) for more details.

If the system monitors the progress of the operation only with R/B#, the last pages of the target program sequence must be programmed with Page Program Confirm command (10h). If the Cache Program command (15h) is used instead, the status bit I/O5 must be polled to find out if the last programming is finished before starting any other operation. Refer to [Section 3.8 on page 22](#) for further information.

If a Multiplane Cache Program operation is interrupted by hardware reset, power failure or other means, the host must ensure that the interrupted pages are not used for further reading or programming operations until the next uninterrupted block erases are complete for the applicable blocks.

3.15 Read ID

The device contains a product identification mode, initiated by writing 90h to the command register, followed by an address input of 00h.

Note: If you want to execute Read Status command (0x70) after Read ID sequence, you should input dummy command (0x00) before Read Status command (0x70).

For the S34ML02G2 and S34ML04G2 devices, five read cycles sequentially output the manufacturer code (01h), and the device code and 3rd, 4th, and 5th cycle ID, respectively. For the S34ML01G2 device, four read cycles sequentially output the manufacturer code (01h), and the device code and 80h, 4th cycle ID, respectively. The command register remains in Read ID mode until further commands are issued to it. [Figure 6.32 on page 58](#) shows the operation sequence, while [Table 3.3](#) to [Table 3.8](#) explain the byte meaning.

Table 3.3 Read ID for Supported Configurations

Density	Org	V _{CC}	1st	2nd	3rd	4th	5th
1 Gb	x8	3.3V	01h	F1h	80h	1Dh	—
2 Gb			01h	DAh	90h	95h	46h
4 Gb			01h	DCh	90h	95h	56h
1 Gb	x16		01h	C1h	80h	5Dh	—
2 Gb			01h	CAh	90h	D5h	46h
4 Gb			01h	CCh	90h	D5h	56h

Table 3.4 Read ID Bytes

Device Identifier Byte	Description
1st	Manufacturer Code
2nd	Device Identifier
3rd	Internal chip number, cell type, etc.
4th	Page Size, Block Size, Spare Size, Serial Access Time, Organization
5th (S34ML02G2, S34ML04G2)	ECC, Multiplane information

3rd ID Data

Table 3.5 Read ID Byte 3 Description

	Description	I/O7	I/O6	I/O5 I/O4	I/O3 I/O2	I/O1 I/O0
Internal Chip Number	1					0 0
	2					0 1
	4					1 0
	8					1 1
Cell type	2-level cell				0 0	
	4-level cell				0 1	
	8-level cell				1 0	
	16-level cell				1 1	
Number of simultaneously programmed pages	1			0 0		
	2			0 1		
	4			1 0		
	8			1 1		
Interleave program Between multiple chips	Not supported		0			
	Supported		1			
Cache Program	Not supported	0				
	Supported	1				

4th ID Data

Table 3.6 Read ID Byte 4 Description — S34ML01G2

	Description	I/O7	I/O6	I/O5 I/O4	I/O3	I/O2	I/O1 I/O0
Page Size (without spare area)	1 kB						0 0
	2 kB						0 1
	4 kB						1 0
	8 kB						1 1
Block Size (without spare area)	64 kB			0 0			
	128 kB			0 1			
	256 kB			1 0			
	512 kB			1 1			
Spare Area Size (byte / 512 byte)	8					0	
	16					1	
Serial Access Time	45 ns	0			0		
	25 ns	0			1		
	Reserved	1			0		
	Reserved	1			1		
Organization	x8		0				
	x16		1				

Table 3.7 Read ID Byte 4 Description — S34ML02G2 and S34ML04G2

	Description	I/O7	I/O6	I/O5 I/O4	I/O3	I/O2	I/O1 I/O0
Page Size (without spare area)	1 kB						0 0
	2 kB						0 1
	4 kB						1 0
	8 kB						1 1
Block Size (without spare area)	64 kB			0 0			
	128 kB			0 1			
	256 kB			1 0			
	512 kB			1 1			
Spare Area Size (byte / 512 byte)	16					0	
	32					1	
Serial Access Time	50 ns / 30 ns	0			0		
	25 ns	1			0		
	Reserved	0			1		
	Reserved	1			1		
Organization	x8		0				
	x16		1				

5th ID Data

Table 3.8 Read ID Byte 5 Description — S34ML02G2 and S34ML04G2

	Description	I/O7	I/O6 I/O5 I/O4	I/O3 I/O2	I/O1 I/O0
ECC Level	1 bit / 512 bytes				00
	2 bit / 512 bytes				01
	4 bit / 512 bytes				10
	8 bit / 512 bytes				11
Plane Number	1			00	
	2			01	
	4			10	
	8			11	
Plane Size (without spare area)	64 Mb		000		
	128 Mb		001		
	256 Mb		010		
	512 Mb		011		
	1 Gb		100		
	2 Gb		101		
	4 Gb		110		
Reserved		0			

3.16 Read ID2

The device contains an alternate identification mode, initiated by writing 30h-65h-00h to the command register, followed by address inputs, followed by command 30h. The address for S34ML01G2 will be 00h-02h-02h-00h. The address for S34ML02G2 and S34ML04G2 will be 00h-02h-02h-00h-00h. The ID2 data can then be read from the device by pulsing RE#. The command register remains in Read ID2 mode until further commands are issued to it. [Figure 6.33 on page 58](#) shows the Read ID2 command sequence. Read ID2 values are all 0xFs, unless specific values are requested when ordering.

3.17 Read ONFI Signature

To retrieve the ONFI signature, the command 90h together with an address of 20h shall be entered (i.e. it is not valid to enter an address of 00h and read 36 bytes to get the ONFI signature). The ONFI signature is the ASCII encoding of 'ONFI' where 'O' = 4Fh, 'N' = 4Eh, 'F' = 46h, and 'I' = 49h. Reading beyond four bytes yields indeterminate values. [Figure 6.34 on page 59](#) shows the operation sequence.

3.18 Read Parameter Page

The device supports the ONFI Read Parameter Page operation, initiated by writing ECh to the command register, followed by an address input of 00h. The host may monitor the R/B# pin or wait for the maximum data transfer time (t_R) before reading the Parameter Page data. The command register remains in Parameter Page mode until further commands are issued to it. If the Status Register is read to determine when the data is ready, the Read Command (00h) must be issued before starting read cycles. [Figure 6.35 on page 59](#) shows the operation sequence, while [Table 3.9](#) explains the parameter fields.

For x16 devices, the upper eight I/Os are not used and are 0xFF.

Note: For 32 nm Cypress NAND, for a particular condition, the Read Parameter Page command does not give the correct values. To overcome this issue, the host must issue a Reset command before the Read Parameter Page command. Issuance of Reset before the Read Parameter Page command will provide the correct values and will not output 00h values.

Table 3.9 Parameter Page Description (Sheet 1 of 3)

Byte	O/M	Description	Values
Revision Information and Features Block			
0-3	M	Parameter page signature Byte 0: 4Fh, "O" Byte 1: 4Eh, "N" Byte 2: 46h, "F" Byte 3: 49h, "I"	4Fh, 4Eh, 46h, 49h
4-5	M	Revision number 2-15 Reserved (0) 1 1 = supports ONFI version 1.0 0 Reserved (0)	02h, 00h
6-7	M	Features supported 5-15 Reserved (0) 4 1 = supports odd to even page Copyback 3 1 = supports interleaved operations 2 1 = supports non-sequential page programming 1 1 = supports multiple LUN operations 0 1 = supports 16-bit data bus width	S34ML01G200 (x8): 14h, 00h S34ML02G200 (x8): 1Ch, 00h S34ML04G200 (x8): 1Ch, 00h S34ML01G204 (x16): 15h, 00h S34ML02G204 (x16): 1Dh, 00h S34ML04G204 (x16): 1Dh, 00h
8-9	M	Optional commands supported 6-15 Reserved (0) 5 1 = supports Read Unique ID (contact factory) 4 1 = supports Copyback 3 1 = supports Read Status Enhanced 2 1 = supports Get Features and Set Features 1 1 = supports Read Cache commands 0 1 = supports Page Cache Program command	S34ML01G2: 33h, 00h S34ML02G2: 3Bh, 00h S34ML04G2: 3Bh, 00h
10-31		Reserved (0)	00h
Manufacturer Information Block			
32-43	M	Device manufacturer (12 ASCII characters)	53h, 50h, 41h, 4Eh, 53h, 49h, 4Fh, 4Eh, 20h, 20h, 20h, 20h
44-63	M	Device model (20 ASCII characters)	S34ML01G2: 53h, 33h, 34h, 4Dh, 4Ch, 30h, 31h, 47h, 32h, 20h, 20h, 20h, 20h, 20h, 20h, 20h, 20h, 20h, 20h, 20h S34ML02G2: 53h, 33h, 34h, 4Dh, 4Ch, 30h, 32h, 47h, 32h, 20h, 20h, 20h, 20h, 20h, 20h, 20h, 20h, 20h, 20h, 20h S34ML04G2: 53h, 33h, 34h, 4Dh, 4Ch, 30h, 34h, 47h, 32h, 20h, 20h, 20h, 20h, 20h, 20h, 20h, 20h, 20h, 20h, 20h
64	M	JEDEC manufacturer ID	01h
65-66	O	Date code	00h
67-79		Reserved (0)	00h

Table 3.9 Parameter Page Description (Sheet 2 of 3)

Byte	O/M	Description	Values
Memory Organization Block			
80-83	M	Number of data bytes per page	00h, 08h, 00h, 00h
84-85	M	Number of spare bytes per page	S34ML01G2: 40h, 00h S34ML02G2: 80h, 00h S34ML04G2: 80h, 00h
86-89	M	Number of data bytes per partial page	00h, 00h, 00h, 00h
90-91	M	Number of spare bytes per partial page	00h, 00h
92-95	M	Number of pages per block	40h, 00h, 00h, 00h
96-99	M	Number of blocks per logical unit (LUN)	S34ML01G2: 00h, 04h, 00h, 00h S34ML02G2: 00h, 08h, 00h, 00h S34ML04G2: 00h, 10h, 00h, 00h
100	M	Number of logical units (LUNs)	01h
101	M	Number of address cycles 4-7 Column address cycles 0-3 Row address cycles	S34ML01G2: 22h S34ML02G2: 23h S34ML04G2: 23h
102	M	Number of bits per cell	01h
103-104	M	Bad blocks maximum per LUN	S34ML01G2: 14h, 00h S34ML02G2: 28h, 00h S34ML04G2: 50h, 00h
105-106	M	Block endurance	01h, 05h
107	M	Guaranteed valid blocks at beginning of target	01h
108-109	M	Block endurance for guaranteed valid blocks	01h, 03h
110	M	Number of programs per page	04h
111	M	Partial programming attributes 5-7 Reserved 4 1 = partial page layout is partial page data followed by partial page spare 1-3 Reserved 0 1 = partial page programming has constraints	00h
112	M	Number of bits ECC correctability	04h
113	M	Number of interleaved address bits 4-7 Reserved (0) 0-3 Number of interleaved address bits	S34ML01G2: 00h S34ML02G2: 01h S34ML04G2: 01h
114	O	Interleaved operation attributes 4-7 Reserved (0) 3 Address restrictions for program cache 2 1 = program cache supported 1 1 = no block address restrictions 0 Overlapped / concurrent interleaving support	S34ML01G2: 00h S34ML02G2: 04h S34ML04G2: 04h
115-127		Reserved (0)	00h
Electrical Parameters Block			
128	M	I/O pin capacitance	0Ah
129-130	M	Timing mode support 6-15 Reserved (0) 5 1 = supports timing mode 5 4 1 = supports timing mode 4 3 1 = supports timing mode 3 2 1 = supports timing mode 2 1 1 = supports timing mode 1 0 1 = supports timing mode 0, shall be 1	1Fh, 00h

Table 3.9 Parameter Page Description (Sheet 3 of 3)

Byte	O/M	Description	Values
131-132	O	Program cache timing mode support 6-15 Reserved (0) 5 1 = supports timing mode 5 4 1 = supports timing mode 4 3 1 = supports timing mode 3 2 1 = supports timing mode 2 1 1 = supports timing mode 1 0 1 = supports timing mode 0	1Fh, 00h
133-134	M	t _{PROG} Maximum page program time (μs)	BCh, 02h
135-136	M	t _{BERS} Maximum block erase time (μs)	10h, 27h
137-138	M	t _R Maximum page read time (μs)	S34ML01G2: 19h, 00h S34ML02G2: 1Eh, 00h S34ML04G2: 1Eh, 00h
139-140	M	t _{CCS} Minimum Change Column setup time (ns)	C8h, 00h
141-163		Reserved (0)	00h
Vendor Block			
164-165	M	Vendor specific Revision number	00h
166-253		Vendor specific	00h
254-255	M	Integrity CRC	S34ML01G200 (x8): 68h, 4Eh S34ML02G200 (x8): 56h, EAh S34ML04G200 (x8): 28h, A1h S34ML01G204 (x16): 1Ah, 38h S34ML02G204 (x16): 24h, 9Ch S34ML04G204 (x16): 5Ah, D7h
Redundant Parameter Pages			
256-511	M	Value of bytes 0-255	Repeat Value of bytes 0-255
512-767	M	Value of bytes 0-255	Repeat Value of bytes 0-255
768+	O	Additional redundant parameter pages	FFh

Note:

1. "O" Stands for Optional, "M" for Mandatory.

3.19 Read Unique ID (Contact Factory)

The device supports the ONFI Read Unique ID function, initiated by writing EDh to the command register, followed by an address input of 00h. The host must monitor the R/B# pin or wait for the maximum data transfer time (t_R) before reading the Unique ID data. The first sixteen bytes returned by the flash is a unique value. The next sixteen bytes returned are the bit-wise complement of the unique value. The host can verify the Unique ID was read correctly by performing an XOR of the two values. The result should be all ones. The command register remains in Unique ID mode until further commands are issued to it. [Figure 6.36 on page 60](#) shows the operation sequence, while [Table 3.10](#) shows the Unique ID data contents. Cypress guarantees unique id support feature with a special model number shown in the OPN combination in [Section 10., Ordering Information on page 69](#).

Note: For 32nm Cypress NAND, for a particular condition, the Read Unique ID command does not give the correct values. To overcome this issue, the host must issue a Reset command before the Read Unique ID command. Issuance of Reset before the Read Unique ID command will provide the correct values and will not output 00h values.

Table 3.10 Unique ID Data Description (Contact Factory) (Sheet 1 of 2)

Byte	Description
0-15	Unique ID
16-31	ID Complement
32-47	Unique ID
48-63	ID Complement
64-79	Unique ID
80-95	ID Complement

Table 3.10 Unique ID Data Description (Contact Factory) (Sheet 2 of 2)

Byte	Description
96-111	Unique ID
112-127	ID Complement
128-143	Unique ID
144-159	ID Complement
160-175	Unique ID
176-191	ID Complement
192-207	Unique ID
208-223	ID Complement
224-239	Unique ID
240-255	ID Complement
256-271	Unique ID
272-287	ID Complement
288-303	Unique ID
304-319	ID Complement
320-335	Unique ID
336-351	ID Complement
352-367	Unique ID
368-383	ID Complement
384-399	Unique ID
400-415	ID Complement
416-431	Unique ID
432-447	ID Complement
448-463	Unique ID
464-479	ID Complement
480-495	Unique ID
496-511	ID Complement

Note:

1. For 32 nm NAND, for a particular condition, if read unique id does not give the correct values, the host must issue a Reset command before the read unique id command. Issuance of Reset before the read unique id command will provide the correct values and will not output false values.

3.20 One-Time Programmable (OTP) Entry

The device contains a one-time programmable (OTP) area, which is accessed by writing 29h-17h-04h-19h to the command register. The device is then ready to accept Page Read and Page Program commands (refer to [Page Read](#) and [Page Program](#) on page 17). The OTP area is of a single erase block size (64 pages), and hence only row addresses between 00h and 3Fh are allowed. The host must issue the Reset command (refer to [Reset](#) on page 23) to exit the OTP area and access the normal flash array. The Block Erase command is not allowed in the OTP area. Refer to [Figure 6.37](#) on page 60 for more detail on the OTP Entry command sequence.

4. Signal Descriptions

4.1 Data Protection and Power On / Off Sequence

The device is designed to offer protection from any involuntary program/erase during power-transitions. An internal voltage detector disables all functions whenever VCC is below about 1.8V.

The power-up and power-down sequence is shown in [Figure 6.38](#) on page 61.

The Ready/Busy signal shall be valid within 100 μ s after the power supplies have reached the minimum values (as specified on), and shall return to one within 5 ms (max).

During this busy time, the device executes the initialization process (cam reading), and dissipates a current I_{CC0} (30 mA max), in addition, it disregards all commands excluding Read Status Register (70h).

At the end of this busy time, the device defaults into “read setup”, thus if the user decides to issue a page read command, the 00h command may be skipped.

The WP# pin provides hardware protection and is recommended to be kept at V_{IL} during power-up and power-down. A recovery time of minimum 100 μ s is required before the internal circuit gets ready for any command sequences as shown in [Figure 6.38 on page 61](#). The two-step command sequence for program/erase provides additional software protection.

4.2 Ready/Busy

The Ready/Busy output provides a method of indicating the completion of a page program, erase, copyback, or read completion. The R/B# pin is normally high and goes to low when the device is busy (after a reset, read, program, or erase operation). It returns to high when the internal controller has finished the operation. The pin is an open-drain driver thereby allowing two or more R/B# outputs to be Or-tied. Because the pull-up resistor value is related to t_f (R/B#) and the current drain during busy (i_{busy}), and output load capacitance is related to t_r , an appropriate value can be obtained with the reference chart shown in [Figure 4.1](#).

For example, for a particular system with 20 pF of output load, t_f from V_{CC} to V_{OL} at 10% to 90% will be 10 ns, whereas for a particular load of 50 pF, Cypress measured it to be 20 ns as shown in [Figure 4.1](#).

Figure 4.1 Ready/Busy Pin Electrical Application

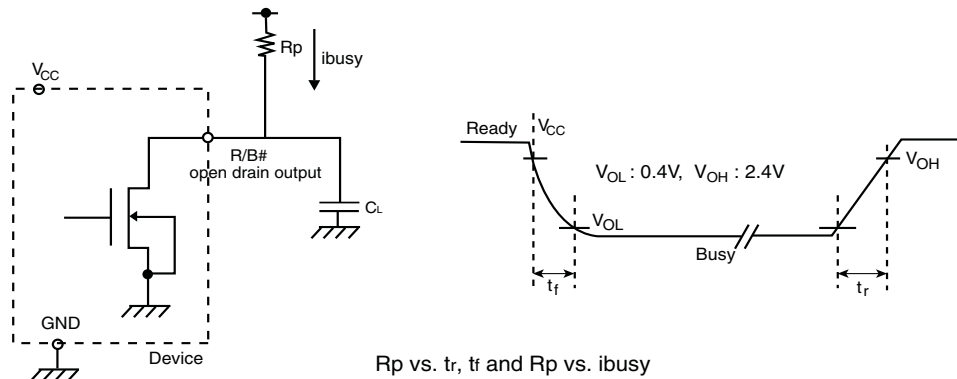

Rp vs. tr, tf and Rp vs. ibusy

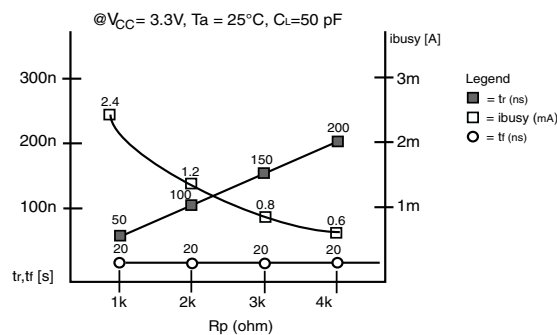

Rp value guidance

$$R_p (\text{min.}) = \frac{V_{CC} (\text{Max.}) - V_{OL} (\text{Max.})}{I_{OL} + \sum I_L} = \frac{3.2V}{8\text{mA} + \sum I_L}$$

where I_L is the sum of the input currents of all devices tied to the R/B# pin.
 $R_p(\text{max})$ is determined by maximum permissible limit of t_r .

4.3 Write Protect Operation

Erase and program operations are aborted if WP# is driven low during busy time, and kept low for about 100 ns. Switching WP# low during this time is equivalent to issuing a Reset command (FFh). The contents of memory cells being altered are no longer valid, as the data will be partially programmed or erased. The

R/B# pin will stay low for t_{RST} (similarly to [Figure 6.24 on page 52](#)). At the end of this time, the command register is ready to process the next command, and the Status Register bit I/O6 will be cleared to 1, while I/O7 value will be related to the WP# value. Refer to [Table 3.2 on page 23](#) for more information on device status.

Erase and program operations are enabled or disabled by setting WP# to high or low respectively, prior to issuing the setup commands (80h or 60h). The level of WP# shall be set t_{WV} ns prior to raising the WE# pin for the set up command, as explained in [Figure 6.39](#) and [Figure 6.40 on page 61](#).

Figure 4.2 WP# Low Timing Requirements during Program/Erase Command Sequence

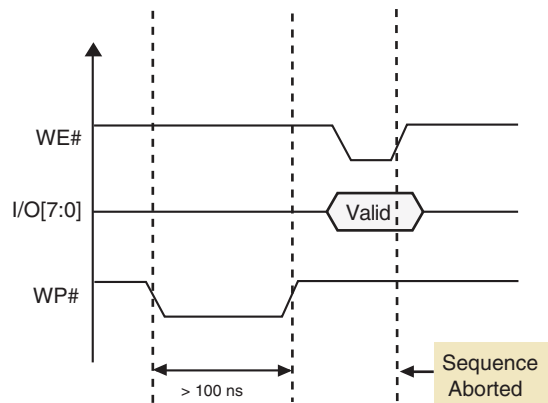

5. Electrical Characteristics

5.1 Valid Blocks

Table 5.1 Valid Blocks

Device	Symbol	Min	Typ	Max	Unit
S34ML01G2	N_{VB}	1004	—	1024	Blocks
S34ML02G2	N_{VB}	2008	—	2048	Blocks
S34ML04G2	N_{VB}	4016	—	4096	Blocks

5.2 Absolute Maximum Ratings

Table 5.2 Absolute Maximum Ratings

Parameter	Symbol	Value	Unit
Ambient Operating Temperature (Industrial Temperature Range)	T_A	-40 to +85	°C
Temperature under Bias	T_{BIAS}	-50 to +125	°C
Storage Temperature	T_{STG}	-65 to +150	°C
Input or Output Voltage	V_{IO} (2)	-0.6 to +4.6	V
Supply Voltage	V_{CC}	-0.6 to +4.6	V

Notes:

1. Except for the rating "Operating Temperature Range", stresses above those listed in the table [Absolute Maximum Ratings](#) "Absolute Maximum Ratings" may cause permanent damage to the device. These are stress ratings only and operation of the device at these or any other conditions above those indicated in the Operating sections of this specification is not implied. Exposure to Absolute Maximum Rating conditions for extended periods may affect device reliability.
2. Minimum Voltage may undershoot to -2V during transition and for less than 20 ns during transitions.
3. Maximum Voltage may overshoot to $V_{CC} + 2.0V$ during transition and for less than 20 ns during transitions.

5.3 Recommended Operating Conditions

Table 5.3 Recommended Operating Conditions

Parameter	Symbol	Min	Typ	Max	Units
Vcc Supply Voltage	V_{CC}	2.7	3.3	3.6	V
Ground Supply Voltage	V_{SS}	0	0	0	V

5.4 AC Test Conditions

Table 5.4 AC Test Conditions

Parameter	Value
Input Pulse Levels	0.0V to V_{CC}
Input Rise and Fall Times	5 ns
Input and Output Timing Levels	$V_{CC} / 2$
Output Load (2.7V - 3.6V)	1 TTL Gate and $CL = 50$ pF

5.5 AC Characteristics

Table 5.5 AC Characteristics

Parameter	Symbol	Min	Max	Unit
ALE to RE# delay	t_{AR}	10	—	ns
ALE hold time	t_{ALH}	5	—	ns
ALE setup time	t_{ALS}	10	—	ns
Address to data loading time	t_{ADL}	70	—	ns
CE# low to RE# low	t_{CR}	10	—	ns
CE# hold time	t_{CH}	5	—	ns
CE# high to output High-Z	t_{CHZ}	—	30	ns
CLE hold time	t_{CLH}	5	—	ns
CLE to RE# delay	t_{CLR}	10	—	ns
CLE setup time	t_{CLS}	10	—	ns
CE# access time	t_{CEA} (4)	—	25	ns
CE# high to output hold	t_{COH} (3)	15	—	ns
CE# high to ALE or CLE don't care	t_{CSD}	10	—	ns
CE# setup time	t_{CS}	20	—	ns
Data hold time	t_{DH}	5	—	ns
Data setup time	t_{DS}	10	—	ns
Data transfer from cell to register (S34ML01G2)	t_R	—	25	μ s
Data transfer from cell to register (S34ML02G2, S34ML04G2)	t_R	—	30	μ s
Output High-Z to RE# low	t_{IR}	0	—	ns
Read cycle time	t_{RC}	25	—	ns
RE# access time	t_{REA}	—	20	ns
RE# high hold time	t_{REH}	10	—	ns
RE# high to output hold	t_{RHOH} (3)	15	—	ns
RE# high to WE# low	t_{RHW}	100	—	ns
RE# high to output High-Z	t_{RHZ}	—	100	ns
RE# low to output hold	t_{RLOH}	5	—	ns
RE# pulse width	t_{RP}	12	—	ns
Ready to RE# low	t_{RR}	20	—	ns
Device resetting time (Read/Program/Erase)	t_{RST}	—	5/10/500	μ s
WE# high to busy	t_{WB}	—	100	ns
Write cycle time	t_{WC}	25	—	ns
WE# high hold time	t_{WH}	10	—	ns
WE# high to RE# low	t_{WHR}	60	—	ns
WE# high to RE# low for Random Data Output	t_{WHR2}	200	—	ns
WE# pulse width	t_{WP}	12	—	ns
Write protect time	t_{WW}	100	—	ns

Notes:

1. The time to Ready depends on the value of the pull-up resistor tied to R/B# pin.
2. If Reset Command (FFh) is written at Ready state, the device goes into Busy for maximum 5 μ s.
3. CE# low to high or RE# low to high can be at different times and produce three cases. Depending on which signal comes high first, either t_{COH} or t_{RHOH} will be met.
4. During data output, t_{CEA} depends partly on t_{CR} (CE# low to RE# low). If t_{CR} exceeds the minimum value specified, then the maximum time for t_{CEA} may also be exceeded ($t_{CEA} = t_{CR} + t_{REA}$).

5.6 DC Characteristics

Table 5.6 DC Characteristics and Operating Conditions

Parameter		Symbol	Test Conditions	Min	Typ	Max	Units
Power On Current		I_{CC0}	FFh command input after power on	—	—	50 per device	mA
Operating Current	Sequential Read	I_{CC1}	$t_{RC} = t_{RC}(\text{min})$ $CE\# = V_{IL}, I_{out} = 0 \text{ mA}$	—	15	30	mA
	Program	I_{CC2}	Normal	—	15	30	mA
			Cache	—	15	30	mA
Erase	I_{CC3}	—	—	15	30	mA	
Standby Current, (TTL)		I_{CC4}	$CE\# = V_{IH}$, $WP\# = 0/V_{CC}$	—	—	1	mA
Standby Current, (CMOS)		I_{CC5}	$CE\# = V_{CC} - 0.2$, $WP\# = 0/V_{CC}$	—	10	50	μA
Input Leakage Current		I_{LI}	$V_{IN} = 0 \text{ to } V_{CC}(\text{max})$	—	—	± 10	μA
Output Leakage Current		I_{LO}	$V_{OUT} = 0 \text{ to } V_{CC}(\text{max})$	—	—	± 10	μA
Input High Voltage		V_{IH}	—	$V_{CC} \times 0.8$	—	$V_{CC} + 0.3$	V
Input Low Voltage		V_{IL}	—	-0.3	—	$V_{CC} \times 0.2$	V
Output High Voltage		V_{OH}	$I_{OH} = -400 \mu\text{A}$	2.4	—	—	V
Output Low Voltage		V_{OL}	$I_{OL} = 2.1 \text{ mA}$	—	—	0.4	V
Output Low Current (R/B#)		$I_{OL(R/B\#)}$	$V_{OL} = 0.4\text{V}$	8	10	—	mA
Erase and Program Lockout Voltage		V_{LKO}	—	—	1.8	—	V

Notes:

1. All V_{CC} pins, and V_{SS} pins respectively, are shorted together.
2. Values listed in this table refer to the complete voltage range for V_{CC} and to a single device in case of device stacking.
3. All current measurements are performed with a $0.1 \mu\text{F}$ capacitor connected between the V_{CC} Supply Voltage pin and the V_{SS} Ground pin.
4. Standby current measurement can be performed after the device has completed the initialization process at power up. Refer to [Section 4.1](#) for more details.

5.7 Pin Capacitance

Table 5.7 Pin Capacitance ($T_A = 25^\circ\text{C}$, $f = 1.0 \text{ MHz}$)

Parameter	Symbol	Test Condition	Min	Max	Unit
Input	C_{IN}	$V_{IN} = 0\text{V}$	—	10	pF
Input / Output	C_{IO}	$V_{IL} = 0\text{V}$	—	10	pF

Note:

1. For the stacked devices version the Input is $10 \text{ pF} \times [\text{number of stacked chips}]$ and the Input/Output is $10 \text{ pF} \times [\text{number of stacked chips}]$.

5.8 Program / Erase Characteristics

Table 5.8 Program / Erase Characteristics

Parameter	Description	Min	Typ	Max	Unit
Program Time / Multiplane Program Time (2)	t_{PROG}	—	300	700	μs
Dummy Busy Time for Multiplane Program (S34ML02G2, S34ML04G2)	t_{DBSY}	—	0.5	1	μs
Cache Program short busy time	t_{CBSYW}	—	5	t_{PROG}	μs
Number of partial Program Cycles in the same page	Main + Spare NOP	—	—	4	Cycle
Block Erase Time / Multiplane Erase Time (S34ML02G2, S34ML04G2)	t_{BERS}	—	3.5	10	ms
Block Erase Time (S34ML01G2)	t_{BERS}	—	3	10	ms
Read Cache busy time (S34ML01G2)	t_{CBSYR}	—	3	t_R	μs
Read Cache busy time (S34ML02G2, S34ML04G2)	t_{CBSYR}	—	5	t_R	μs

Notes:

1. Typical program time is defined as the time within which more than 50% of the whole pages are programmed ($V_{CC} = 3.3V, 25^{\circ}C$).
2. Copy Back Read and Copy Back Program for a given plane must be between odd address pages or between even address pages for the device to meet the program time (t_{PROG}) specification. Copy Back Program may not meet this specification when copying from an odd address page (source page) to an even address page (target page) or from an even address page (source page) to an odd address page (target page).

6. Timing Diagrams

6.1 Command Latch Cycle

Command Input bus operation is used to give a command to the memory device. Commands are accepted with Chip Enable low, Command Latch Enable High, Address Latch Enable low, and Read Enable High and latched on the rising edge of Write Enable. Moreover for commands that starts a modify operation (write/ erase) the Write Protect pin must be high.

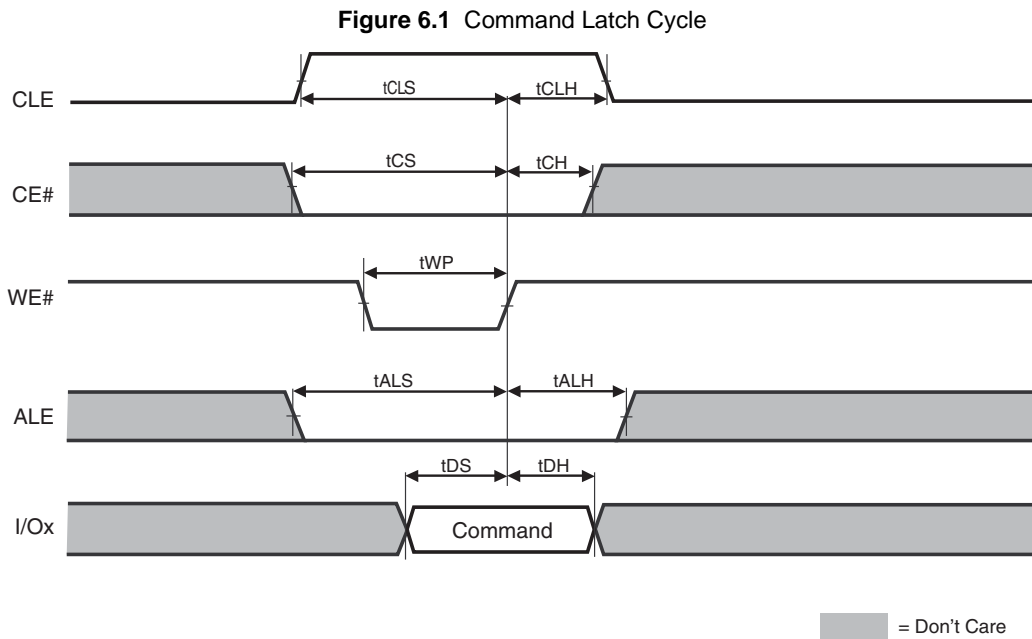

6.2 Address Latch Cycle

Address Input bus operation allows the insertion of the memory address. To insert the 27 (x8 Device) addresses needed to access the 1 Gb, four write cycles are needed. Addresses are accepted with Chip Enable low, Address Latch Enable High, Command Latch Enable low, and Read Enable High and latched on the rising edge of Write Enable. Moreover, for commands that start a modify operation (write/ erase) the Write Protect pin must be high.

Figure 6.2 Address Latch Cycle

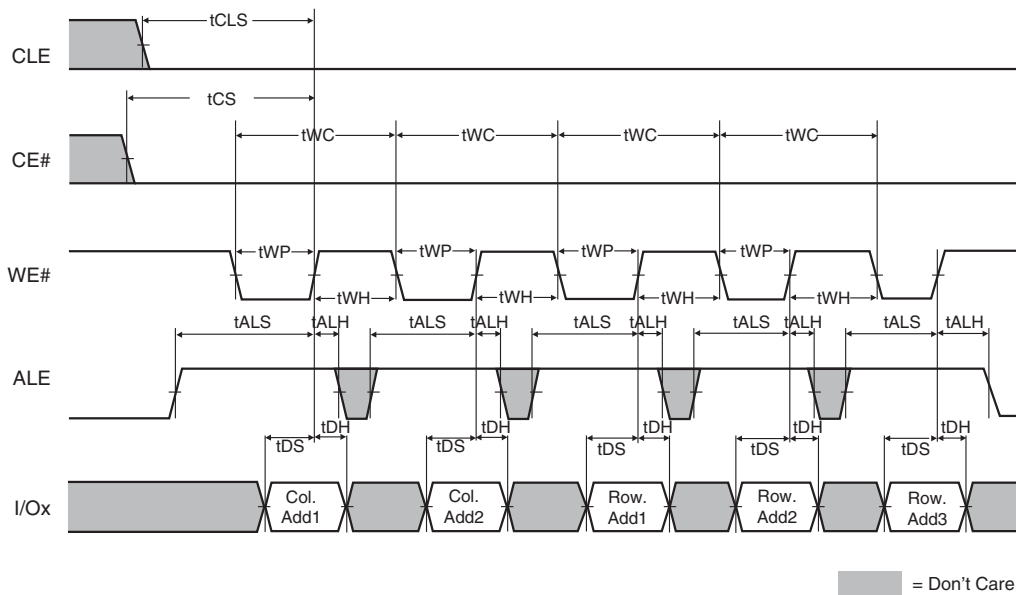

6.3 Data Input Cycle Timing

Data Input bus operation allows the data to be programmed to be sent to the device. The data insertion is serially, and timed by the Write Enable cycles. Data is accepted only with Chip Enable low, Address Latch Enable low, Command Latch Enable low, Read Enable High, and Write Protect High and latched on the rising edge of Write Enable.

Figure 6.3 Input Data Latch Cycle

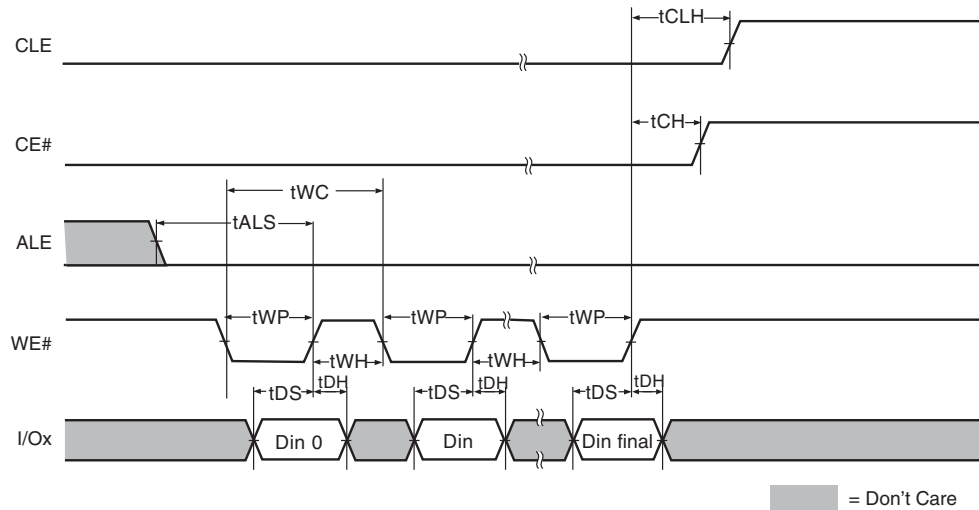

6.4 Data Output Cycle Timing (CLE=L, WE#=H, ALE=L, WP#=H)

Figure 6.4 Data Output Cycle Timing

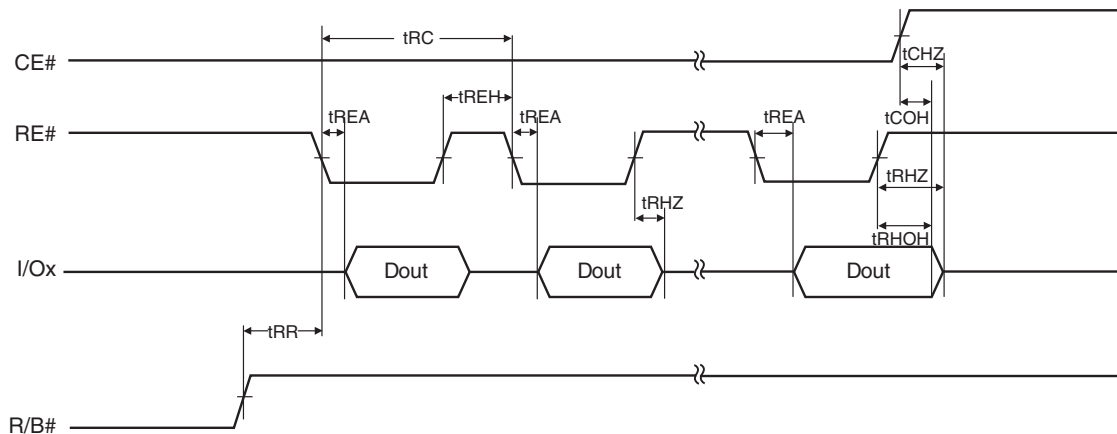

Notes:

1. Transition is measured at ± 200 mV from steady state voltage with load.
2. This parameter is sampled and not 100% tested.
3. t_{RHOH} starts to be valid when frequency is lower than 33 MHz.

6.5 Data Output Cycle Timing (EDO Type, CLE=L, WE#=H, ALE=L)

Figure 6.5 Data Output Cycle Timing (EDO)

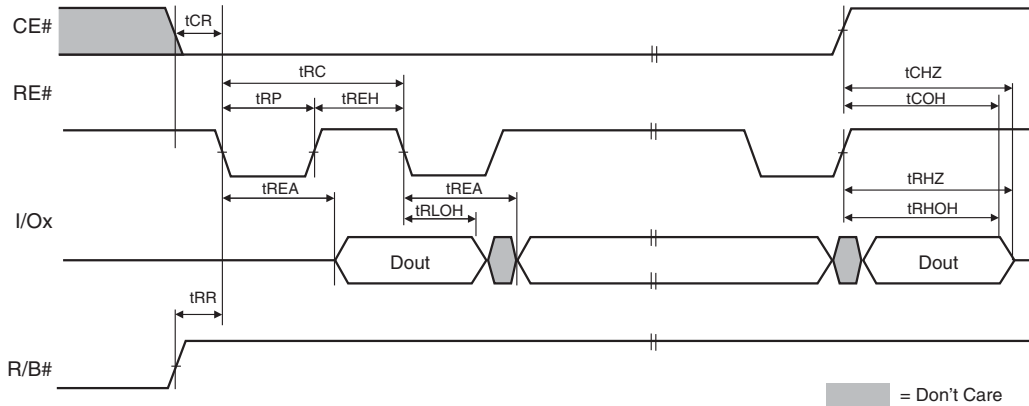

Notes:

1. Transition is measured at ± 200 mV from steady state voltage with load.
2. This parameter is sampled and not 100% tested.
3. t_{RLOH} is valid when frequency is higher than 33 MHz.
4. t_{RHOH} starts to be valid when frequency is lower than 33 MHz.

6.6 Page Read Operation

Figure 6.6 Page Read Operation (Read One Page)

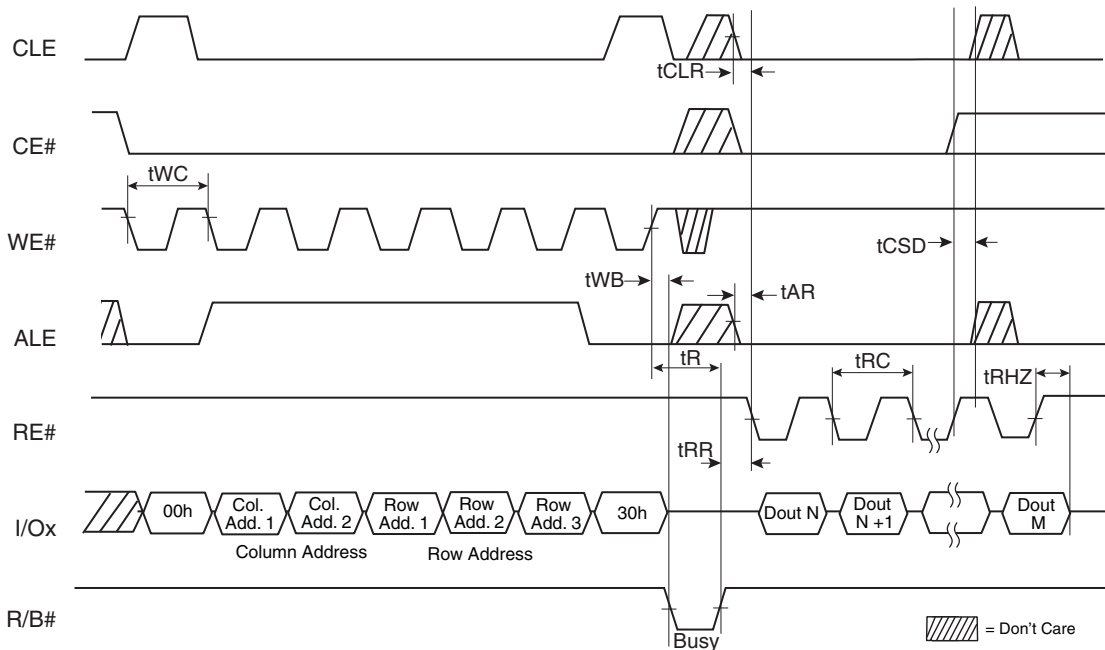

Note:

1. If Status Register polling is used to determine completion of the read operation, the Read Command (00h) must be issued before data can be read from the page buffer.

6.7 Page Read Operation (Interrupted by CE#)

Figure 6.7 Page Read Operation Interrupted by CE#

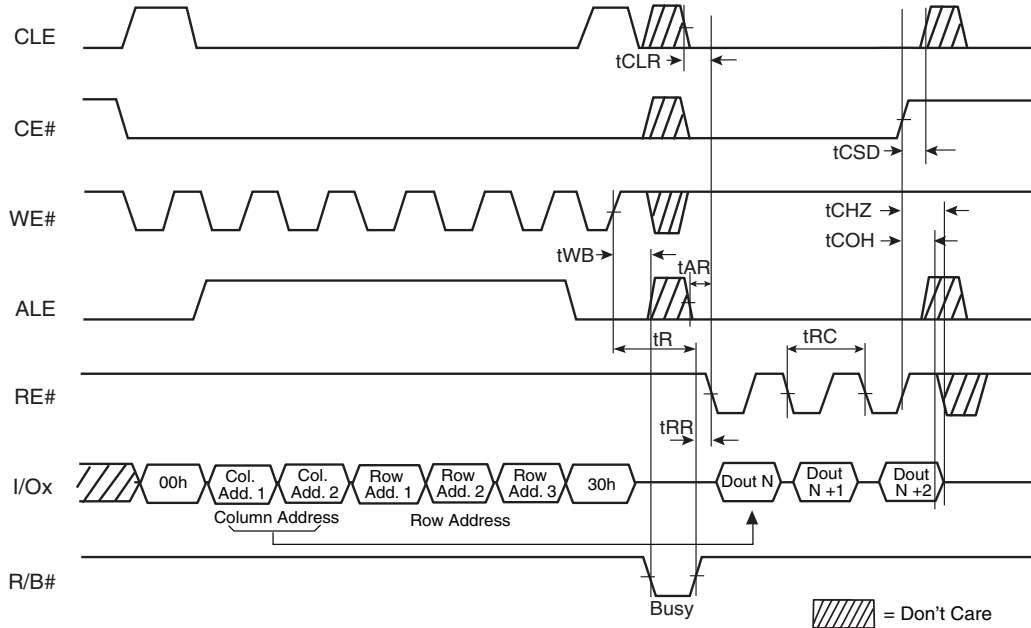

6.8 Page Read Operation Timing with CE# Don't Care

Figure 6.8 Page Read Operation Timing with CE# Don't Care

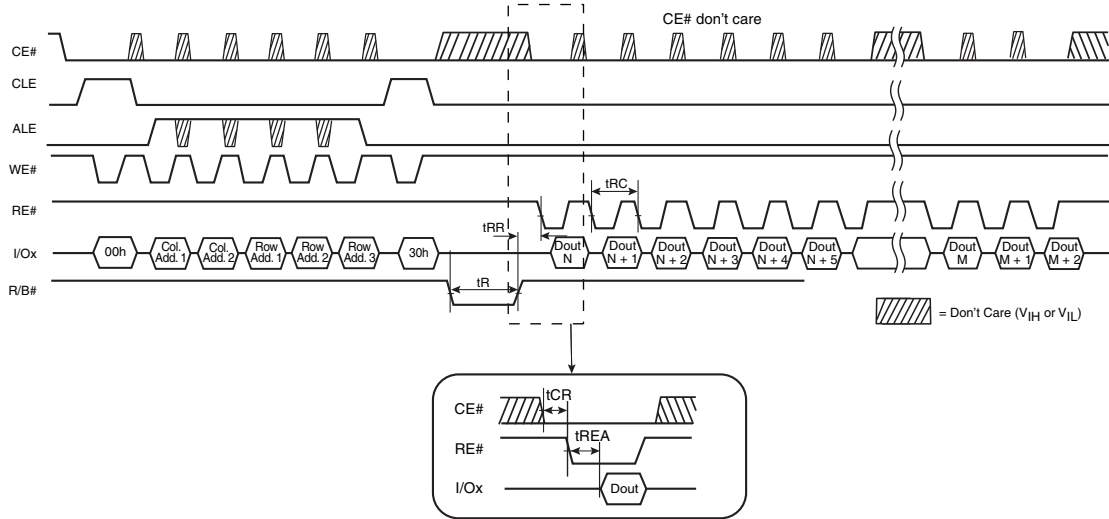

6.9 Page Program Operation

Figure 6.9 Page Program Operation

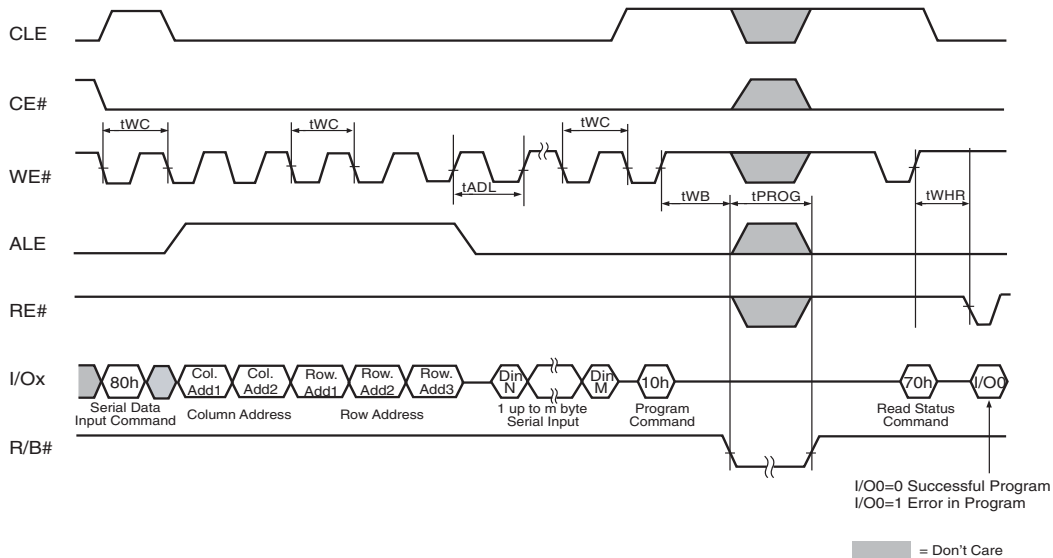

Note:

1. t_{ADL} is the time from the WE# rising edge of final address cycle to the WE# rising edge of first data cycle.

6.10 Page Program Operation Timing with CE# Don't Care

Figure 6.10 Page Program Operation Timing with CE# Don't Care

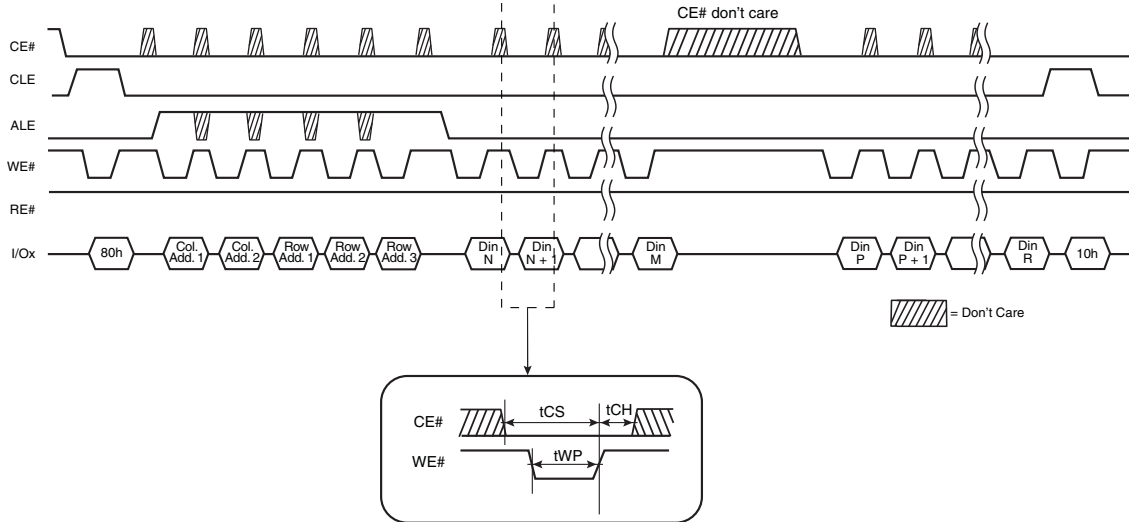

6.11 Page Program Operation with Random Data Input

Figure 6.11 Random Data Input

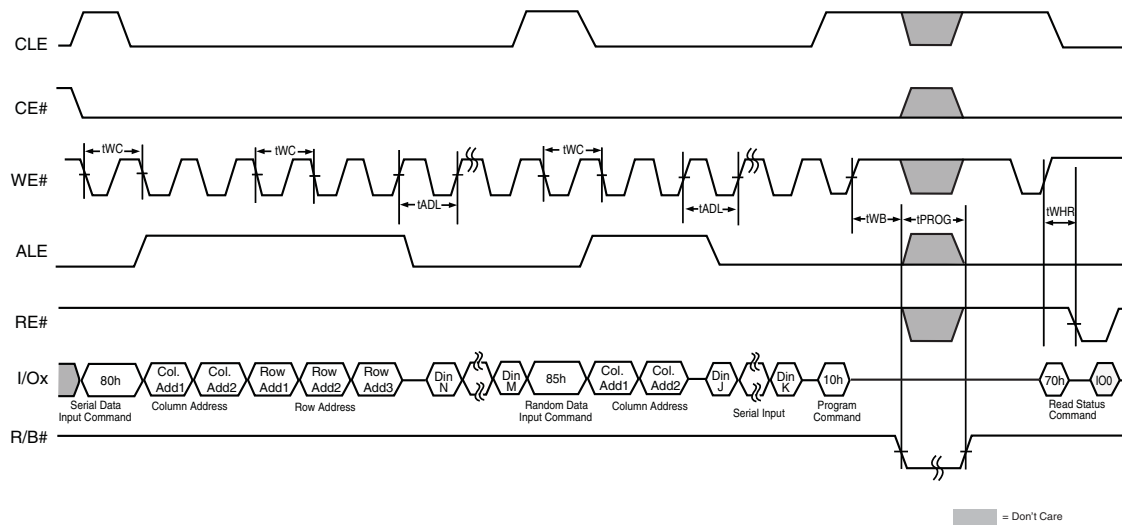

Note:

1. t_{ADL} is the time from the WE# rising edge of final address cycle to the WE# rising edge of first data cycle.

6.12 Random Data Output In a Page

Figure 6.12 Random Data Output

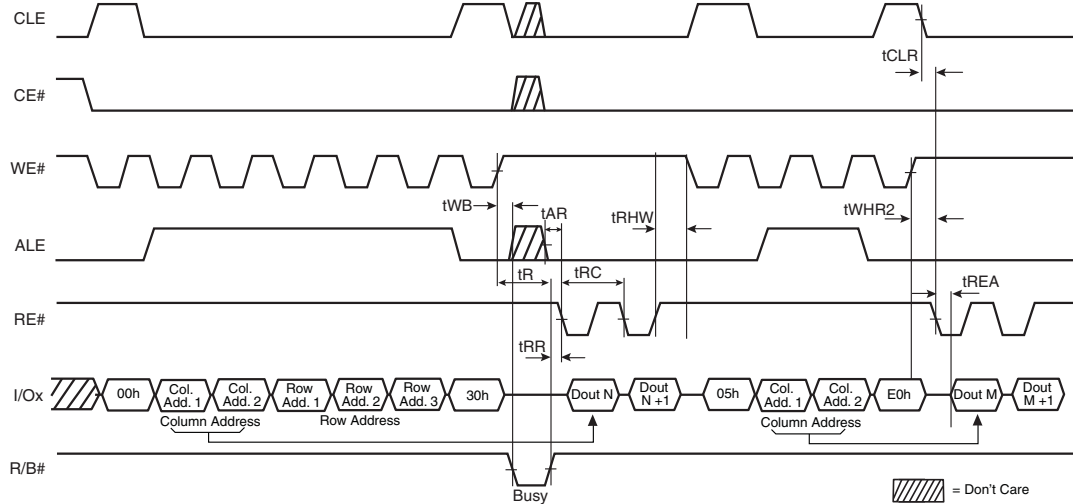

6.13 Multiplane Page Program Operation — S34ML02G2 and S34ML04G2

Figure 6.13 Multiplane Page Program

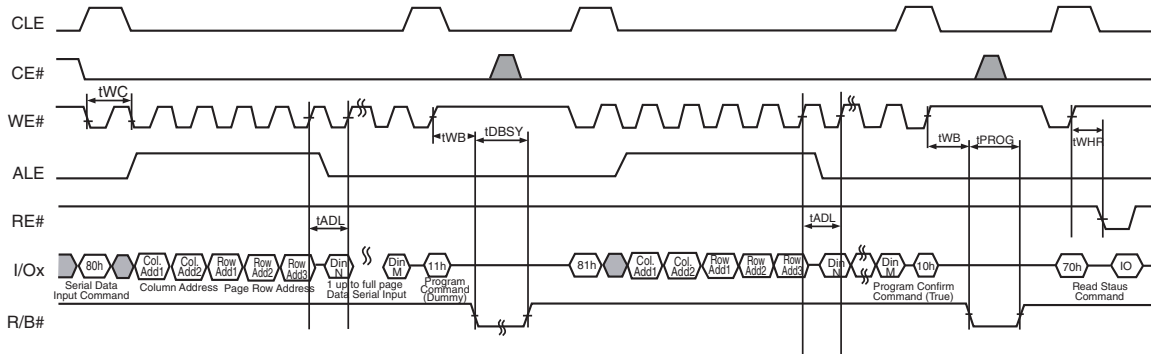

Ex.) Address Restriction for Multiplane Page Program

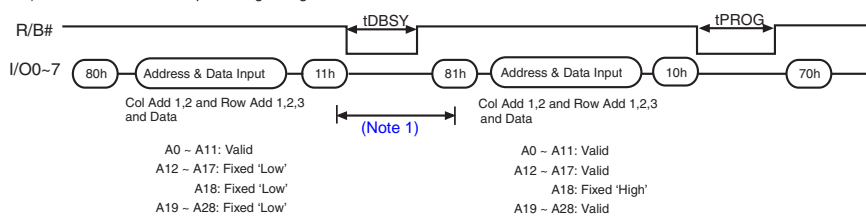

Notes:

- Any command between 11h and 81h is prohibited except 70h, 78h, and FFh.
- A18 is the plane address bit for x8 devices. A17 is the plane address bit for x16 devices.

Figure 6.14 Multiplane Page Program (ONFI 1.0 Protocol)

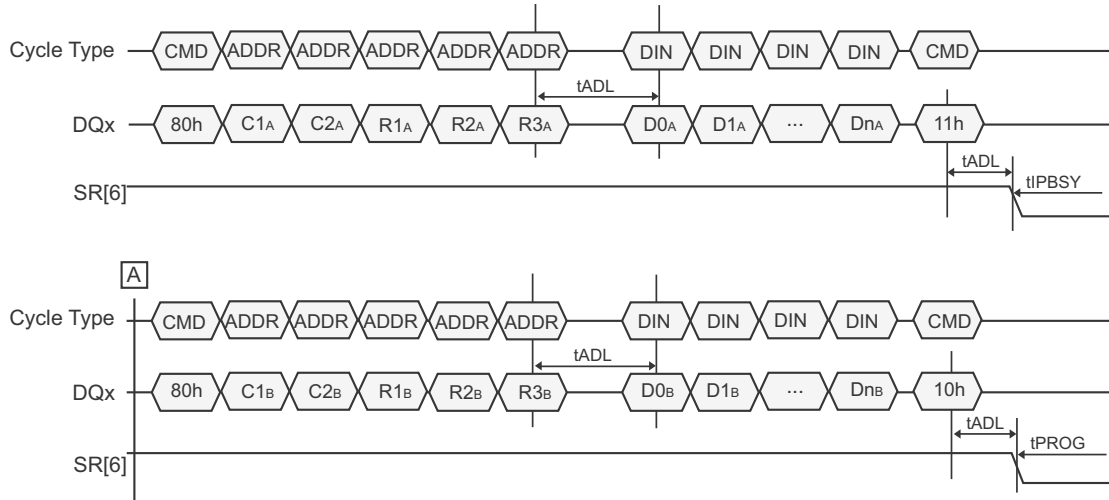

Notes:

1. C1A-C2A Column address for page A. C1A is the least significant byte.
2. R1A-R3A Row address for page A. R1A is the least significant byte.
3. D0A-DnA Data to program for page A.
4. C1B-C2B Column address for page B. C1B is the least significant byte.
5. R1B-R3B Row address for page B. R1B is the least significant byte.
6. D0B-DnB Data to program for page B.
7. The block address bits must be the same except for the bit(s) that select the plane.

6.14 Block Erase Operation

Figure 6.15 Block Erase Operation (Erase One Block)

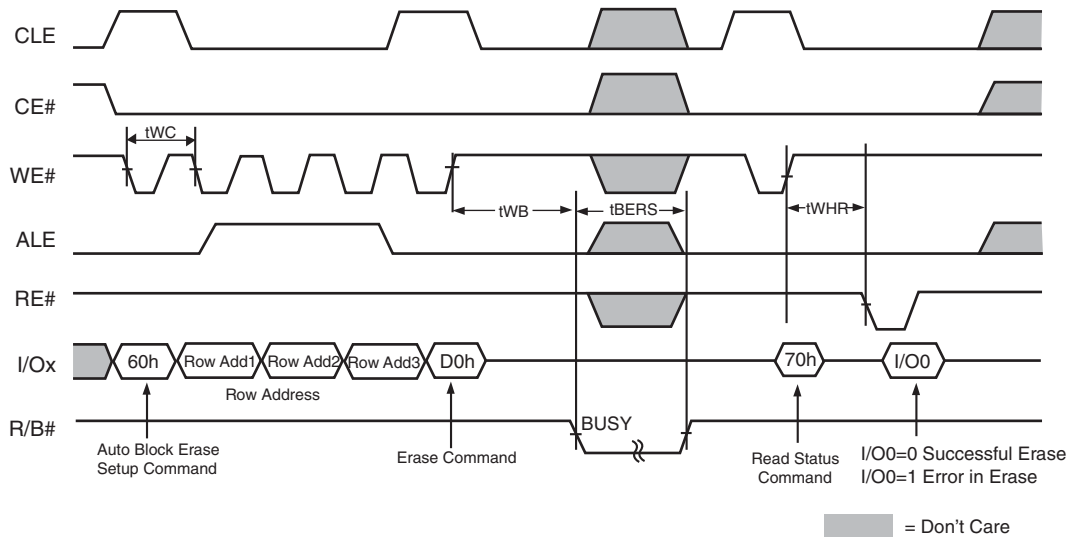

6.15 Multiplane Block Erase — S34ML02G2 and S34ML04G2

Figure 6.16 Multiplane Block Erase

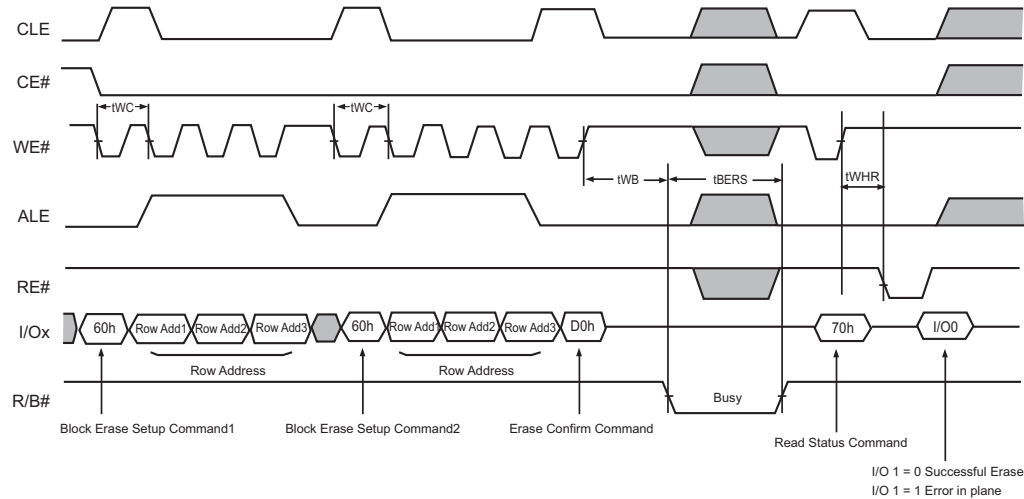

Ex.) Address Restriction for Multiplane Block Erase Operation

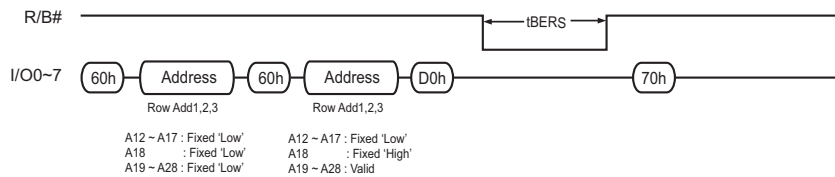

Note:

1. A18 is the plane address bit for x8 devices. A17 is the plane address bit for x16 devices.

Figure 6.17 Multiplane Block Erase (ONFI 1.0 Protocol)

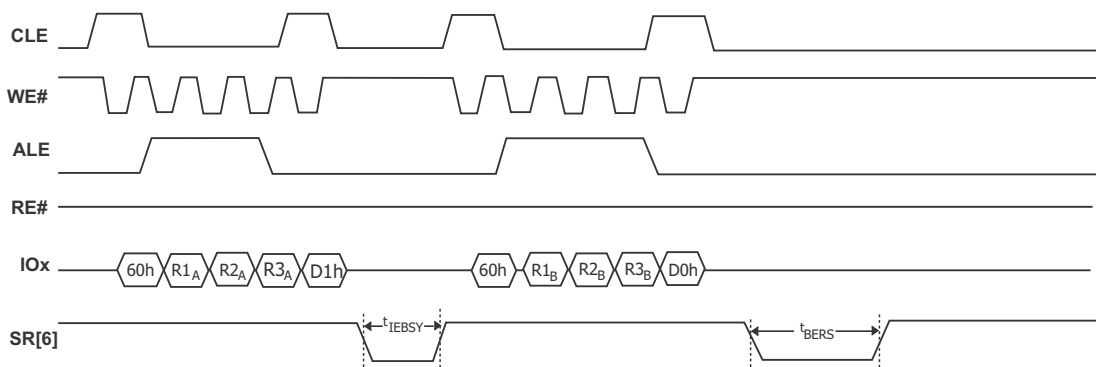

Notes:

1. R1A-R3A Row address for block on plane 0. R1A is the least significant byte.
2. R1B-R3B Row address for block on plane 1. R1B is the least significant byte.
3. The block address bits must be the same except for the bit(s) that select the plane.

6.16 Copy Back Read with Optional Data Readout

Figure 6.18 Copy Back Read with Optional Data Readout

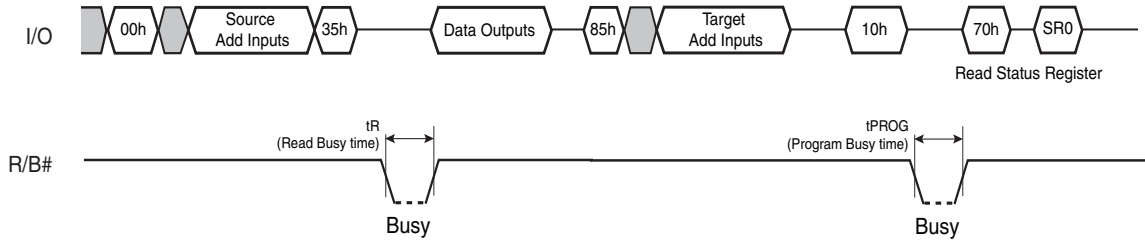

6.17 Copy Back Program Operation With Random Data Input

Figure 6.19 Copy Back Program with Random Data Input

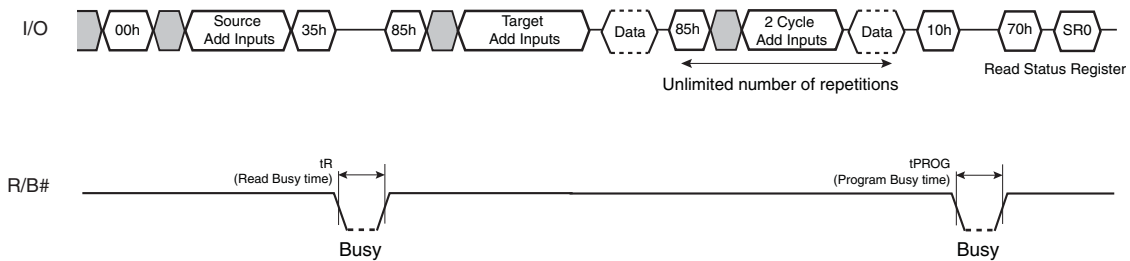

6.18 Multiplane Copy Back Program — S34ML02G2 and S34ML04G2

Figure 6.20 Multiplane Copy Back Program

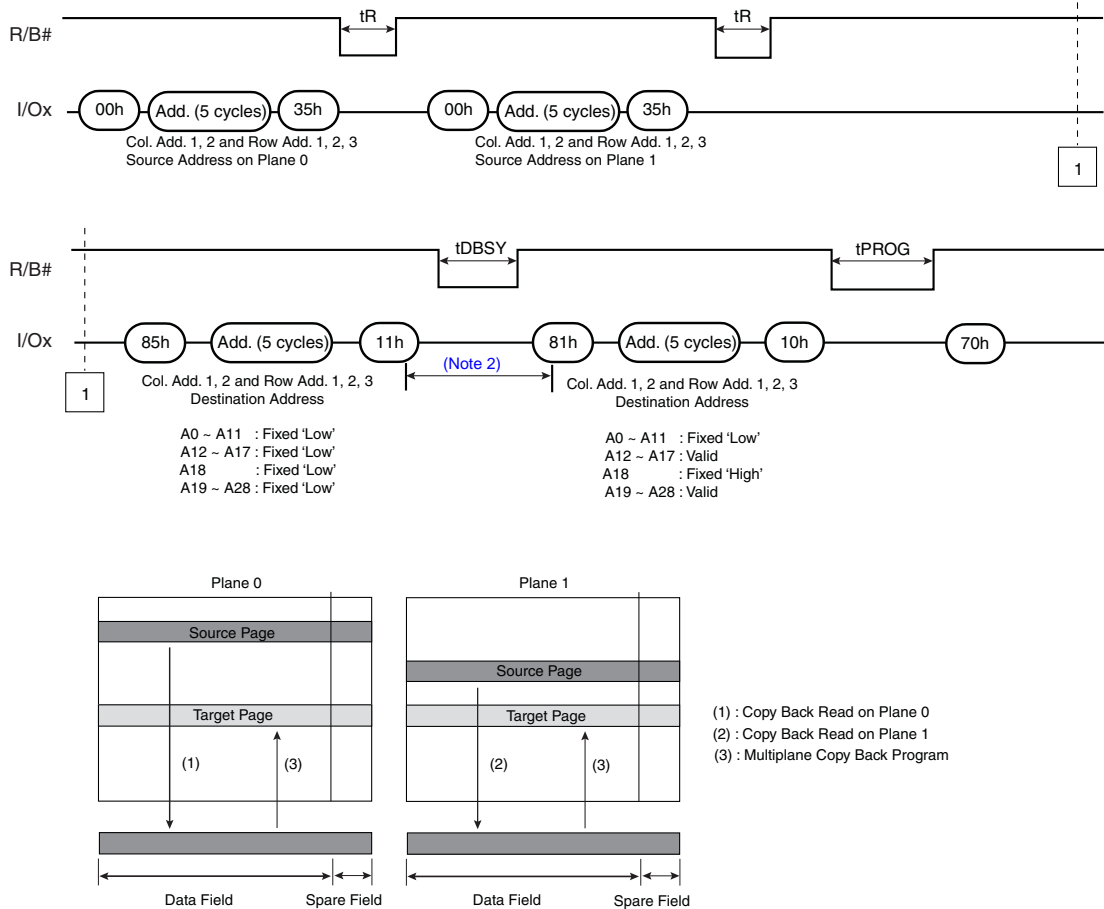

Notes:

1. Copy Back Program operation is allowed only within the same memory plane.
2. Any command between 11h and 81h is prohibited except 70h, 78h, and FFh.
3. A18 is the plane address bit for x8 devices. A17 is the plane address bit for x16 devices.

Figure 6.21 Multiplane Copy Back Program (ONFI 1.0 Protocol)

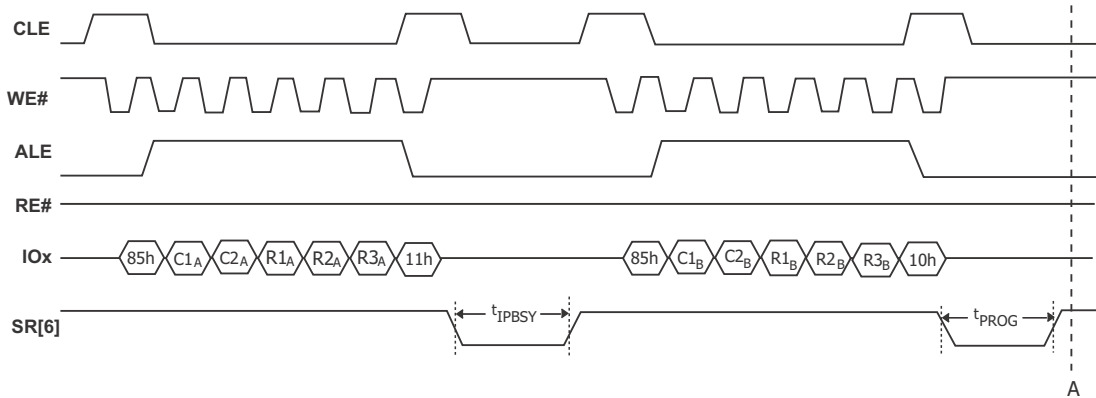

Notes:

1. C1A-C2A Column address for page A. C1A is the least significant byte.
2. R1A-R3A Row address for page A. R1A is the least significant byte.
3. C1B-C2B Column address for page B. C1B is the least significant byte.
4. R1B-R3B Row address for page B. R1B is the least significant byte.
5. The block address bits must be the same except for the bit(s) that select the plane.

6.19 Read Status Register Timing

Figure 6.22 Read Status Cycle

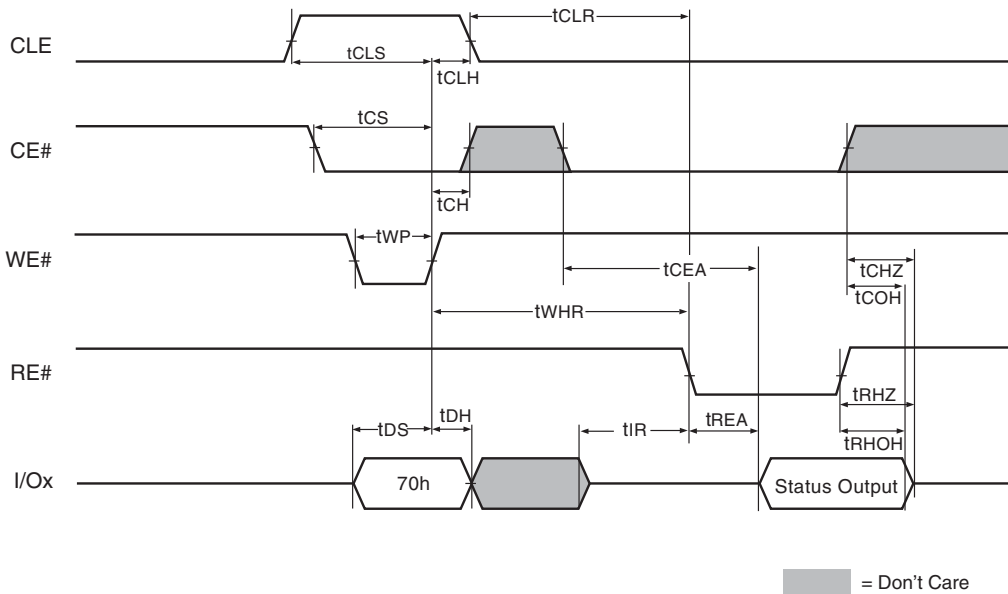

6.20 Read Status Enhanced Timing

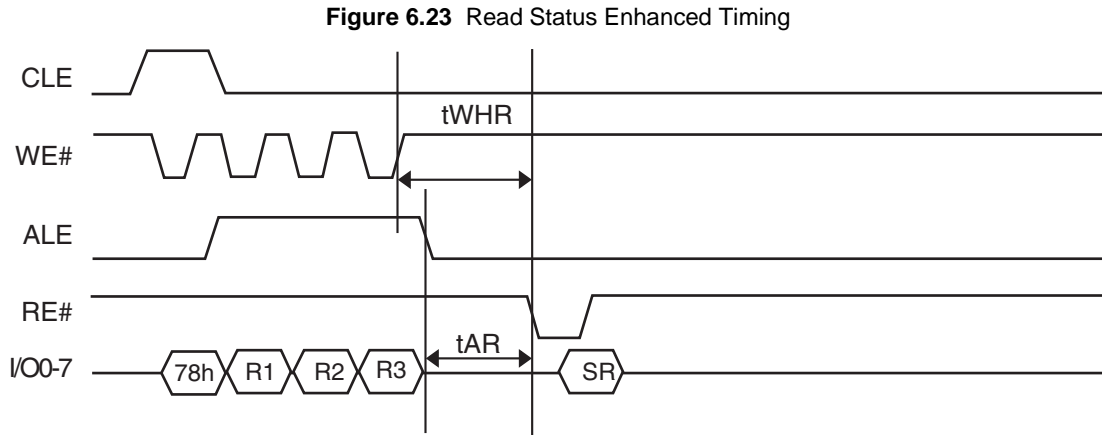

6.21 Reset Operation Timing

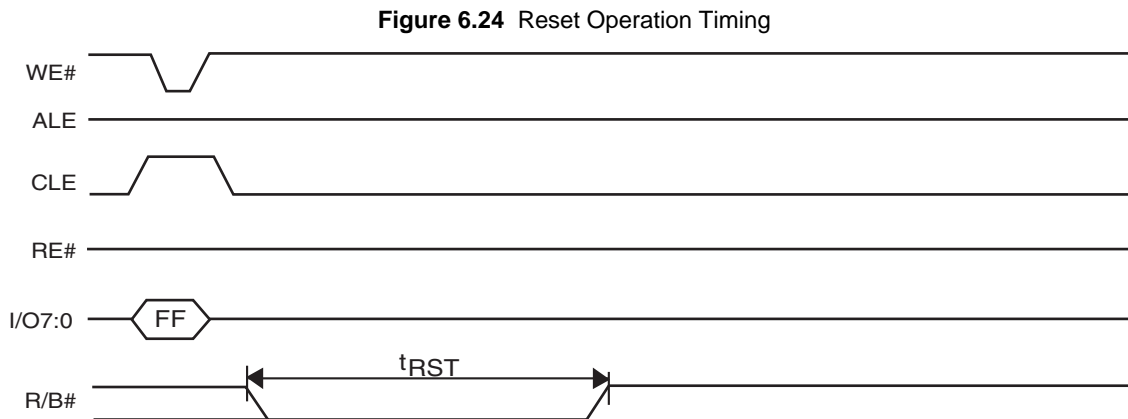

6.22 Read Cache

Figure 6.25 Read Cache Operation Timing

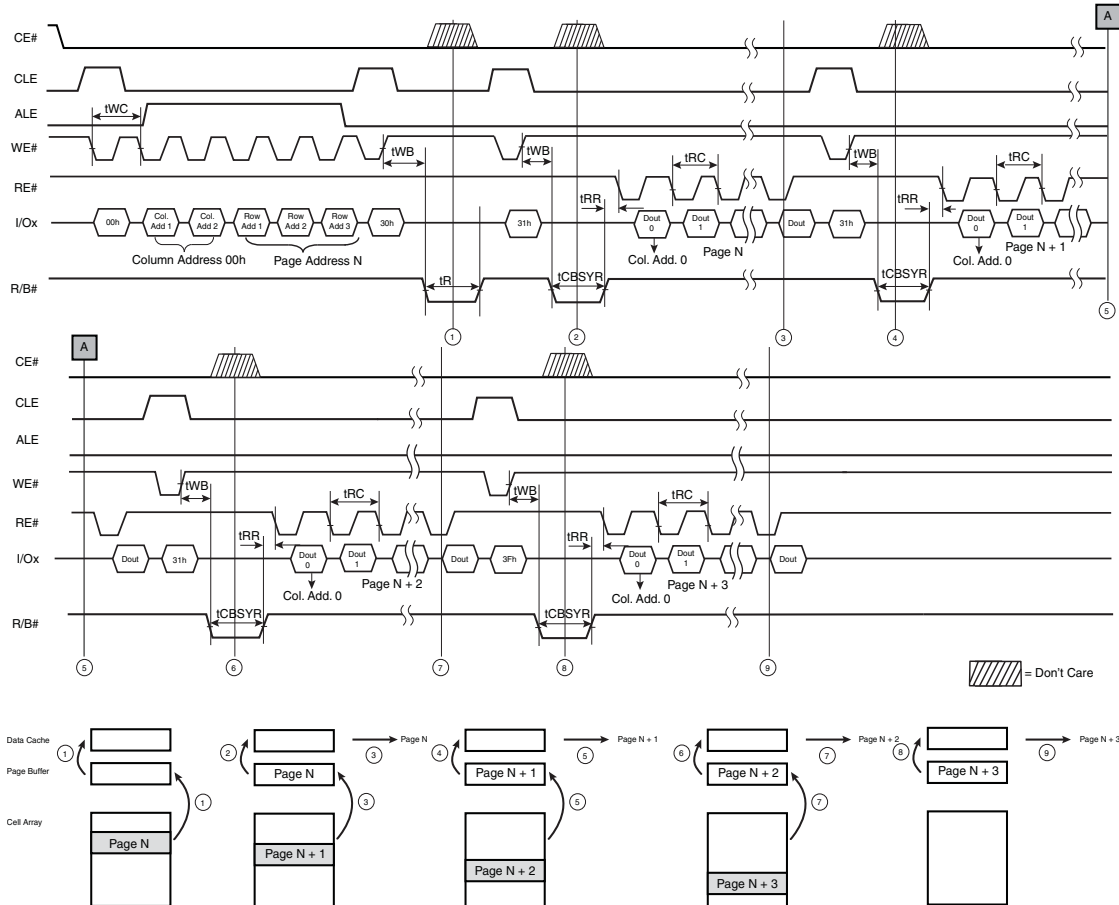

Figure 6.26 "Sequential" Read Cache Timing, Start (and Continuation) of Cache Operation

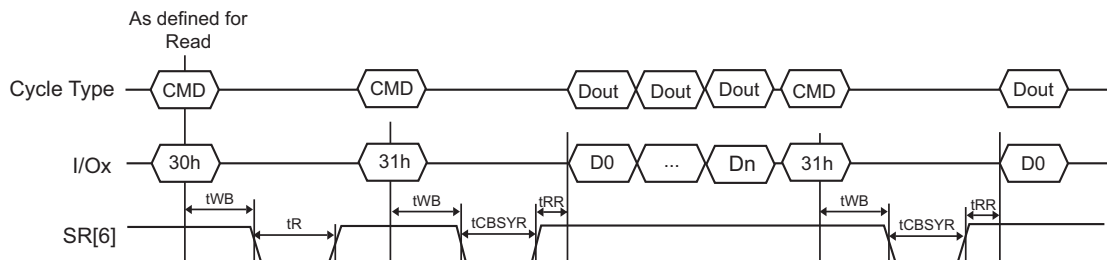

Figure 6.27 “Random” Read Cache Timing, Start (and Continuation) of Cache Operation

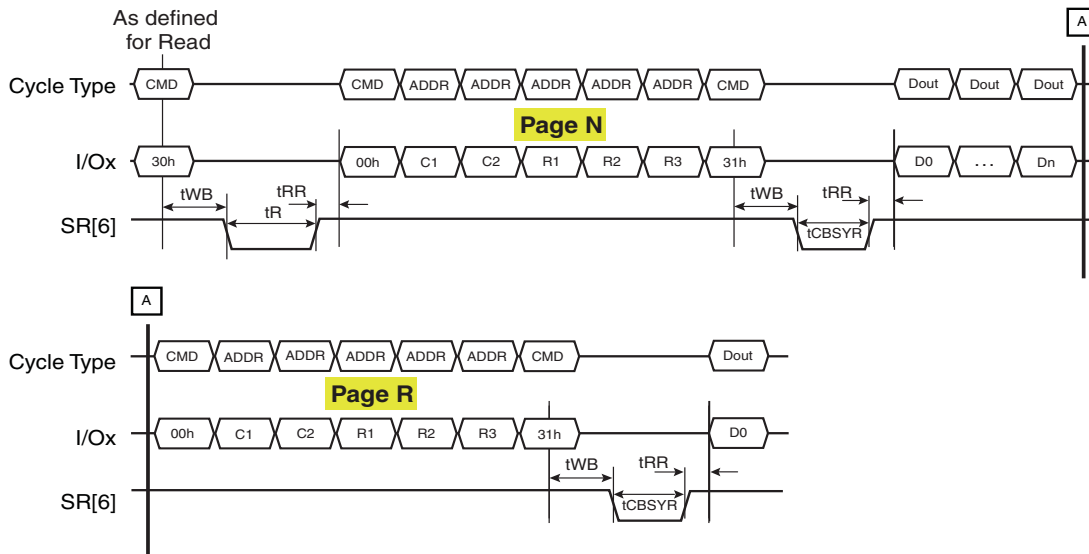
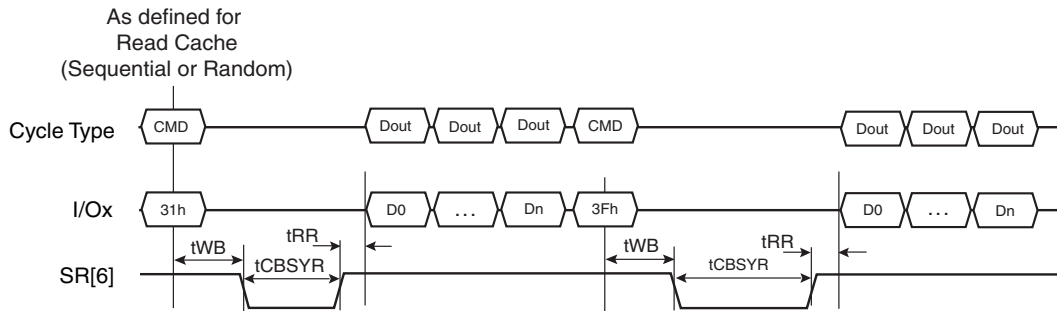
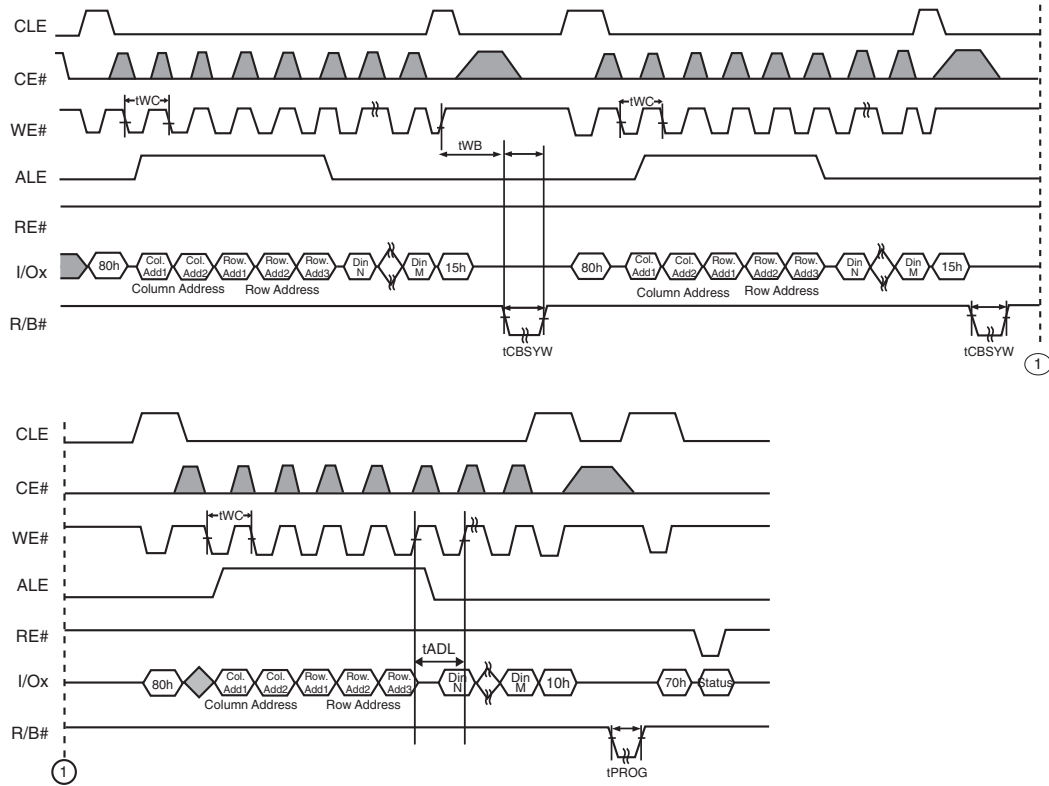

Figure 6.28 Read Cache Timing, End Of Cache Operation



6.23 Cache Program

Figure 6.29 Cache Program



6.24 Multiplane Cache Program — S34ML02G2 and S34ML04G2

Figure 6.30 Multiplane Cache Program

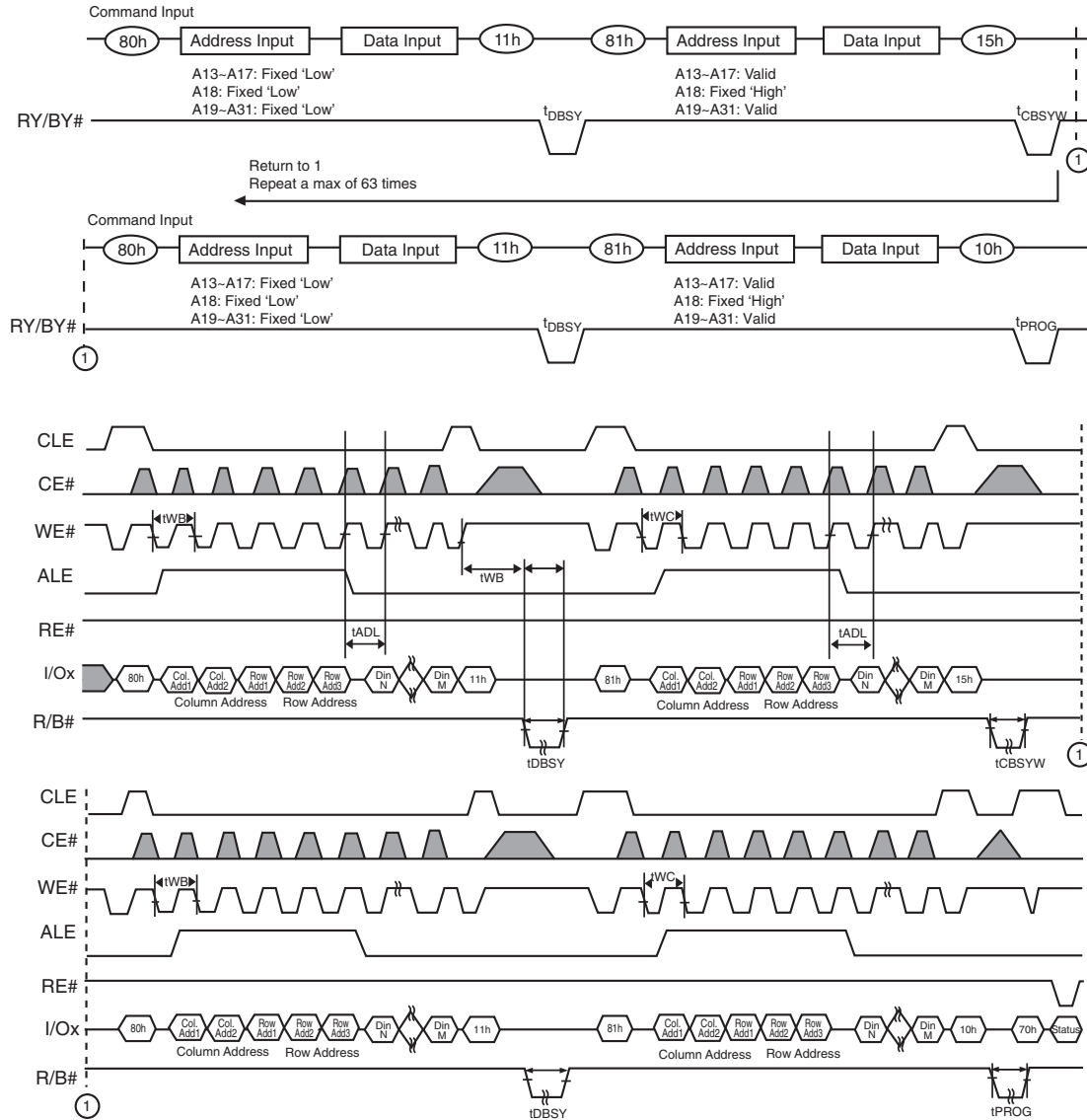

Notes:

1. Read Status Register (70h) is used in the figure. Read Status Enhanced (78h) can be also used.
2. A18 is the plane address bit for x8 devices. A17 is the plane address bit for x16 devices.

Figure 6.31 Multiplane Cache Program (ONFI 1.0 Protocol)

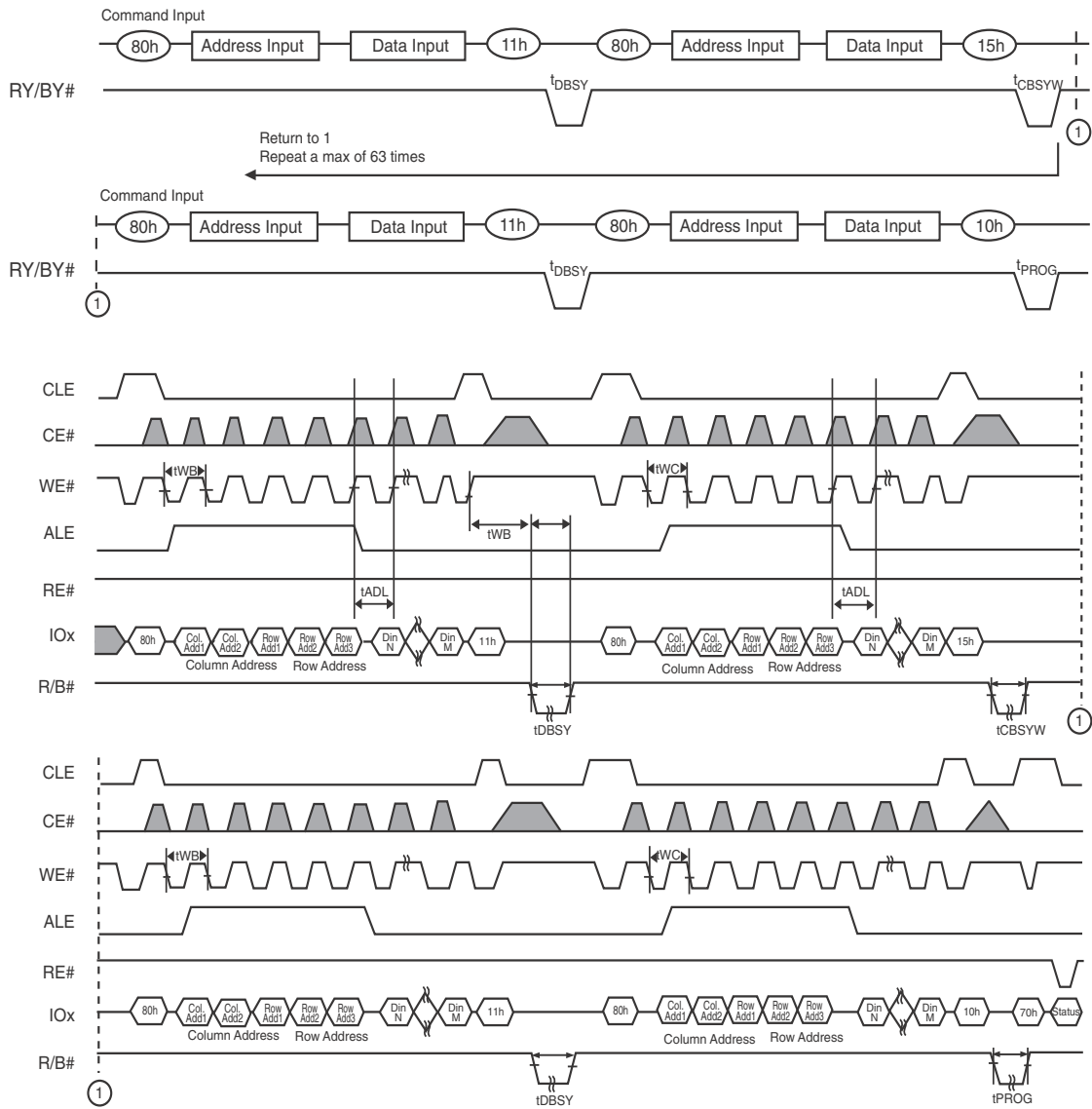

Notes:

1. The block address bits must be the same except for the bit(s) that select the plane.
2. Read Status register (70h) is used in the figure. Read Status Enhanced (78h) can be also used.

6.25 Read ID Operation Timing

Figure 6.32 Read ID Operation Timing

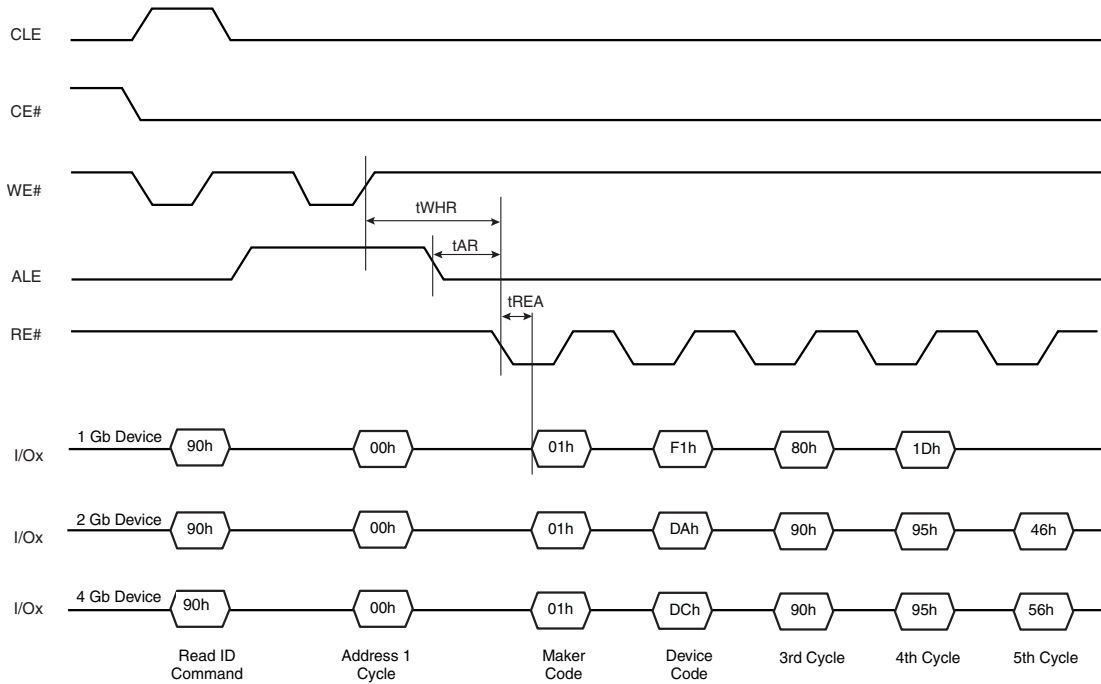

6.26 Read ID2 Operation Timing

Figure 6.33 Read ID2 Operation Timing

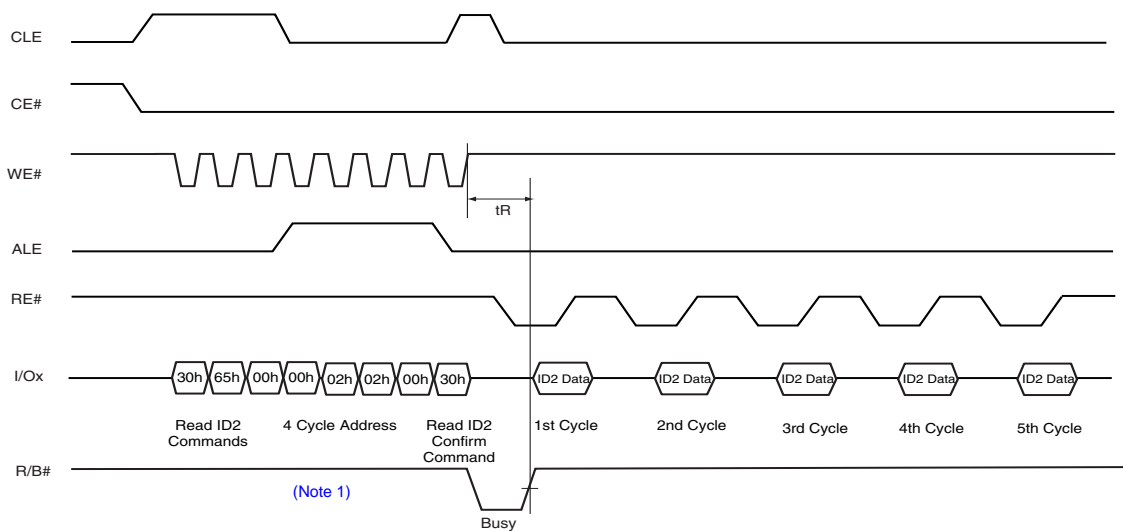

Notes:

- 4-cycle address is shown for the S34ML01G2. For S34ML02G2 and S34ML04G2, insert an additional address cycle of 00h.
- If Status Register polling is used to determine completion of the Read ID2 operation, the Read Command (00h) must be issued before ID2 data can be read from the flash.

6.27 Read ONFI Signature Timing

Figure 6.34 ONFI Signature Timing

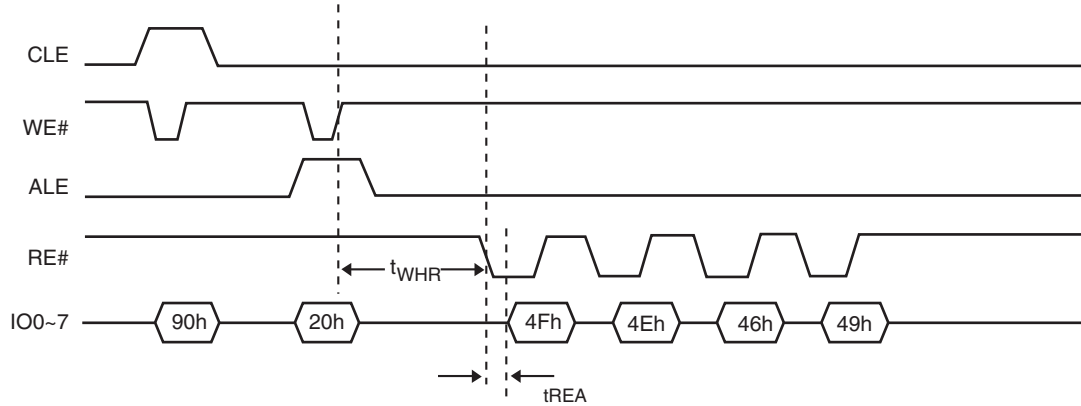

6.28 Read Parameter Page Timing

Figure 6.35 Read Parameter Page Timing

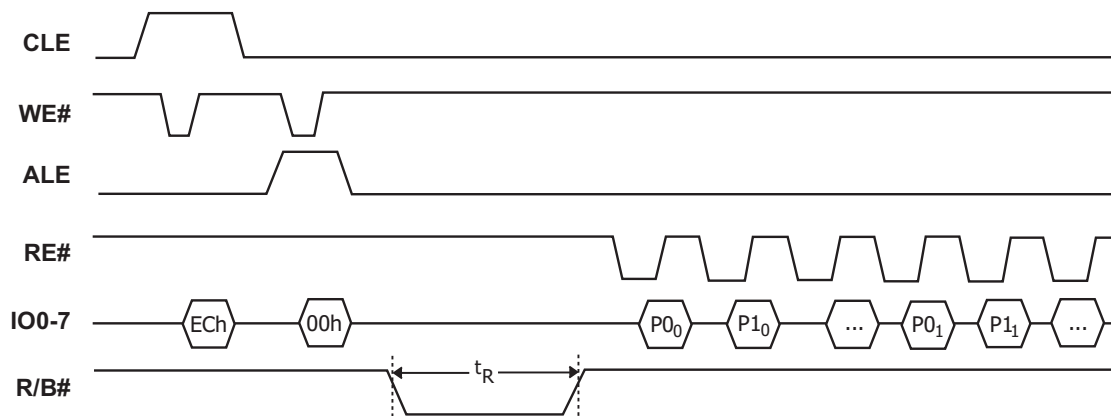

Note:

1. If Status Register polling is used to determine completion of the read operation, the Read Command (00h) must be issued before data can be read from the page buffer.

6.29 Read Unique ID Timing (Contact Factory)

Figure 6.36 Read Unique ID Timing

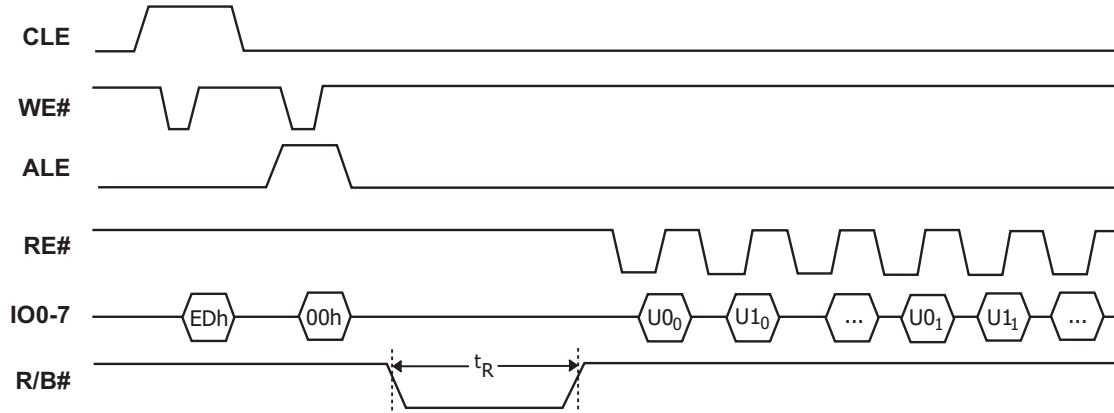

6.30 OTP Entry Timing

Figure 6.37 OTP Entry Timing

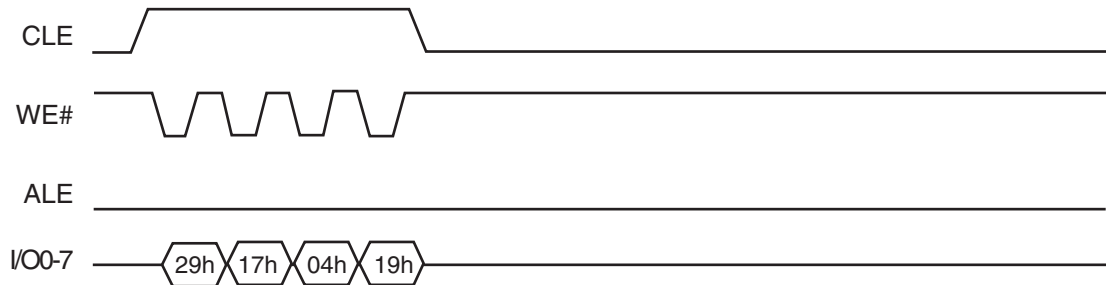

6.31 Power On and Data Protection Timing

Figure 6.38 Power On and Data Protection Timing

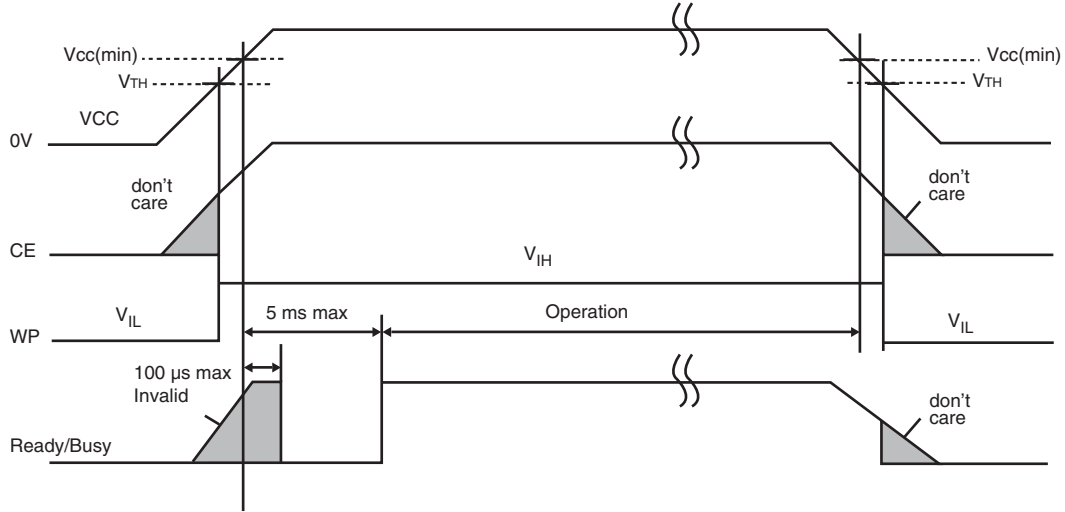

Note:
1. $V_{TH} = 1.8$ Volts.

6.32 WP# Handling

Figure 6.39 Program Enabling / Disabling Through WP# Handling

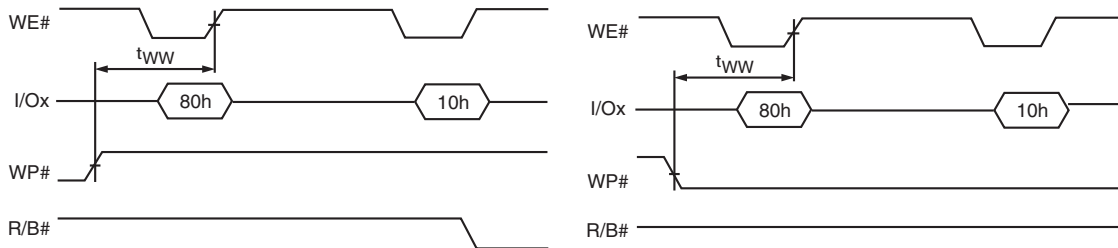
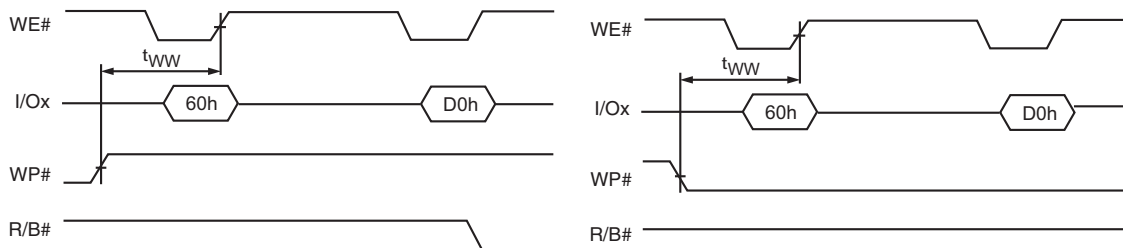

Figure 6.40 Erase Enabling / Disabling Through WP# Handling



7. Physical Interface

7.1 Physical Diagram

7.1.1 48-Pin Thin Small Outline Package (TSOP1)

Figure 7.1 TS/TSR 48 — 48-lead Plastic Thin Small Outline, 12 x 20 mm, Package Outline

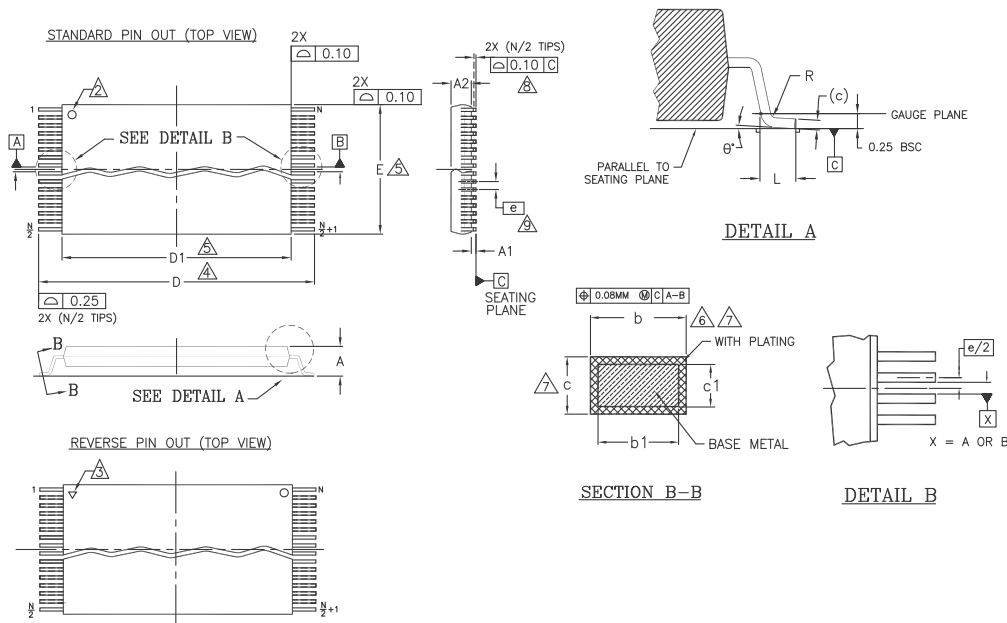

PACKAGE	TS/TSR 48		
JEDEC	MO-142 (D) DD		
SYMBOL	MIN	NOM	MAX
A	---	---	1.20
A1	0.05	---	0.15
A2	0.95	1.00	1.05
b1	0.17	0.20	0.23
b	0.17	0.22	0.27
c1	0.10	---	0.16
c	0.10	---	0.21
D	19.80	20.00	20.20
D1	18.30	18.40	18.50
E	11.90	12.00	12.10
e	0.50 BASIC		
L	0.50	0.60	0.70
Θ	0°	---	8
R	0.08	---	0.20
N	48		

NOTES:

1. DIMENSIONS ARE IN MILLIMETERS (mm). (DIMENSIONING AND TOLERANCING CONFORM TO ANSI Y14.5M-1994).
2. PIN 1 IDENTIFIER FOR STANDARD PIN OUT (DIE UP).
3. PIN 1 IDENTIFIER FOR REVERSE PIN OUT (DIE DOWN): INK OR LASER MARK.
4. TO BE DETERMINED AT THE SEATING PLANE [-C-]. THE SEATING PLANE IS DEFINED AS THE PLANE OF CONTACT THAT IS MADE WHEN THE PACKAGE LEADS ARE ALLOWED TO REST FREELY ON A FLAT HORIZONTAL SURFACE.
5. DIMENSIONS D1 AND E DO NOT INCLUDE MOLD PROTRUSION. ALLOWABLE MOLD PROTRUSION ON E IS 0.15mm PER SIDE AND ON D1 IS 0.25mm PER SIDE.
6. DIMENSION b DOES NOT INCLUDE DAMBAR PROTRUSION. ALLOWABLE DAMBAR PROTRUSION SHALL BE 0.08mm TOTAL IN EXCESS OF b DIMENSION AT MAX. MATERIAL CONDITION. DAMBAR CANNOT BE LOCATED ON LOWER RADIUS OR THE FOOT. MINIMUM SPACE BETWEEN PROTRUSION AND AN ADJACENT LEAD TO BE 0.07mm.
7. THESE DIMENSIONS APPLY TO THE FLAT SECTION OF THE LEAD BETWEEN 0.10mm AND 0.25mm FROM THE LEAD TIP.
8. LEAD COPLANARITY SHALL BE WITHIN 0.10mm AS MEASURED FROM THE SEATING PLANE.
9. DIMENSION "e" IS MEASURED AT THE CENTERLINE OF THE LEADS.

5006 \ f16-038 \ 6.5.13

7.1.2 63-Ball, Ball Grid Array (BGA)

Figure 7.2 VBM063 — 63-Pin BGA, 11 mm x 9 mm Package

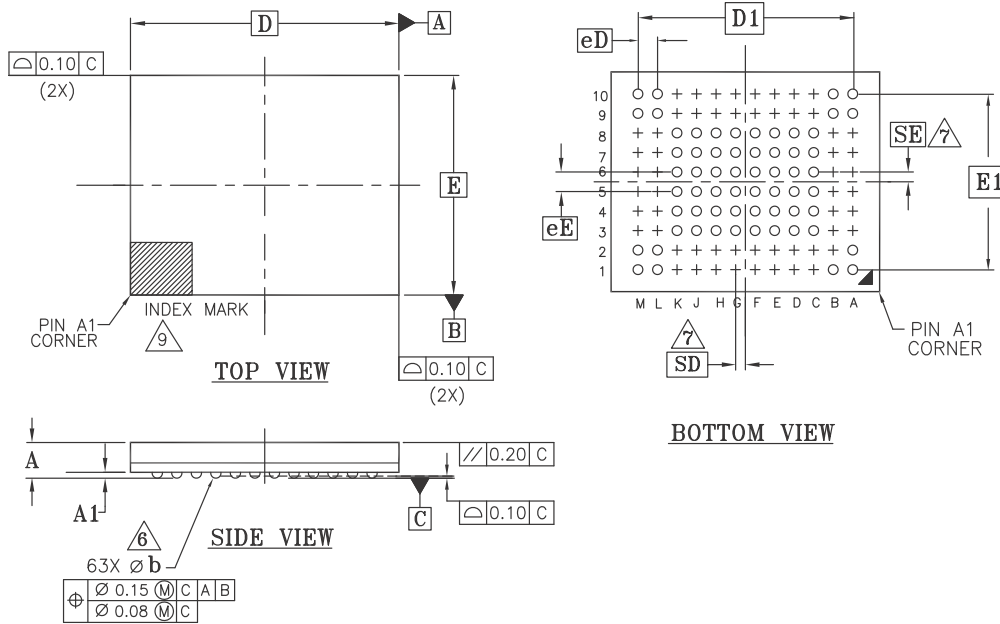

PACKAGE	VBM 063			
JEDEC	M0-207(M)			
	11.00 mm x 9.00 mm NOM PACKAGE			
SYMBOL	MIN	NOM	MAX	NOTE
A	---	---	1.00	PROFILE
A1	0.25	---	---	BALL HEIGHT
D		11.00 BSC.		BODY SIZE
E		9.00 BSC.		BODY SIZE
D1		8.80 BSC.		MATRIX FOOTPRINT
E1		7.20 BSC.		MATRIX FOOTPRINT
MD		12		MATRIX SIZE D DIRECTION
ME		10		MATRIX SIZE E DIRECTION
n		63		BALL COUNT
$\varnothing b$	0.40	0.45	0.50	BALL DIAMETER
eE		0.80 BSC.		BALL PITCH
eD		0.80 BSC.		BALL PITCH
SD		0.40 BSC.		SOLDER BALL PLACEMENT
SE		0.40 BSC.		SOLDER BALL PLACEMENT
	A3-A8, B2-B8, C1, C2, C9, C10 D1, D2, D9, D10, E1, E2, E9, E10 F1, F2, F9, F10, G1, G2, G9, G10 H1, H2, H9, H10, J1, J2, J9, J10 K1, K2, K9, K10 L3-L8, M3-M8			DEPOPULATED SOLDER BALLS

NOTES:

- DIMENSIONING AND TOLERANCING METHODS PER ASME Y14.5M-1994.
- ALL DIMENSIONS ARE IN MILLIMETERS.
- BALL POSITION DESIGNATION PER JEP95, SECTION 3, SPP-020.
- [e] REPRESENTS THE SOLDER BALL GRID PITCH.
- SYMBOL "MD" IS THE BALL MATRIX SIZE IN THE "D" DIRECTION.

SYMBOL "ME" IS THE BALL MATRIX SIZE IN THE "E" DIRECTION.

n IS THE TOTAL NUMBER OF POPULATED SOLDER BALL POSITIONS FOR MATRIX SIZE MD X ME.

$\Delta 6$ DIMENSION "b" IS MEASURED AT THE MAXIMUM BALL DIAMETER IN A PLANE PARALLEL TO DATUM C.

$\Delta 7$ "SD" AND "SE" ARE MEASURED WITH RESPECT TO DATUMS A AND B AND DEFINE THE POSITION OF THE CENTER SOLDER BALL IN THE OUTER ROW.

WHEN THERE IS AN ODD NUMBER OF SOLDER BALLS IN THE OUTER ROW, "SD" OR "SE" = 0.

WHEN THERE IS AN EVEN NUMBER OF SOLDER BALLS IN THE OUTER ROW, "SD" = eD/2 AND "SE" = eE/2.

8. "+" INDICATES THE THEORETICAL CENTER OF DEPOPULATED BALLS.

$\Delta 9$ A1 CORNER TO BE IDENTIFIED BY CHAMFER, LASER OR INK MARK, METALLIZED MARK INDENTATION OR OTHER MEANS.

g50111-16-038.25 | 6.5.13

7.1.3 67-Ball, Ball Grid Array (BGA)

Figure 7.3 VBT067 — 67-Ball BGA, 8 x 6.5 mm Package

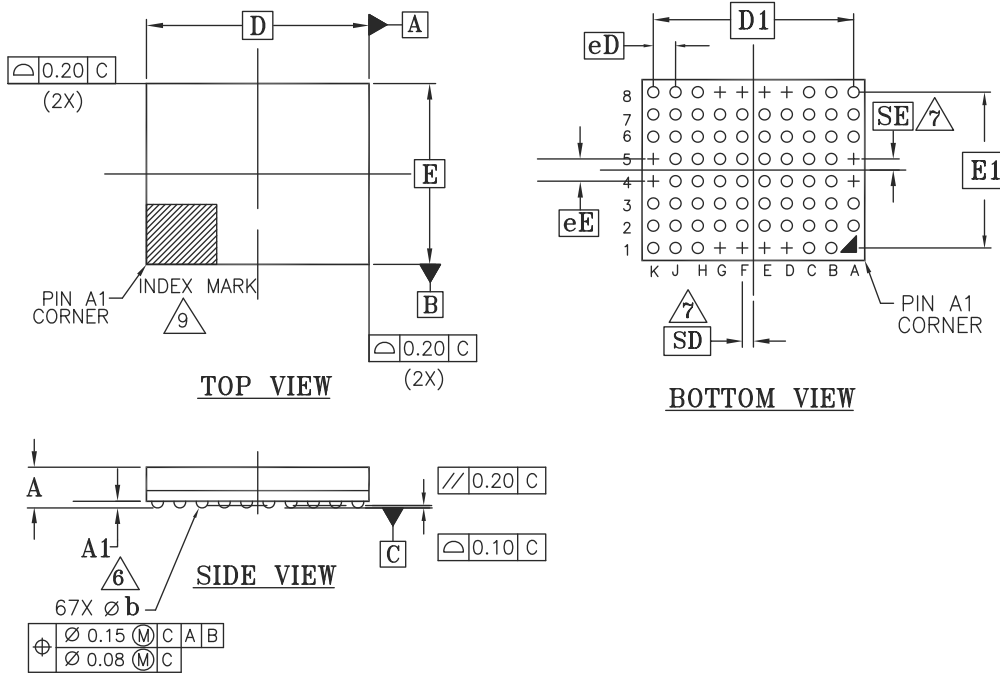

PACKAGE	VBT 067			NOTE
JEDEC	N/A			
D X E	8.00 mm x 6.50 mm PACKAGE			
SYMBOL	MIN	NOM	MAX	
A	---	---	1.00	PROFILE
A1	0.22	---	---	BALL HEIGHT
D	8.00 BSC			BODY SIZE
E	6.50 BSC			BODY SIZE
D1	7.20 BSC			MATRIX FOOTPRINT
E1	5.60 BSC			MATRIX FOOTPRINT
MD	10			MATRIX SIZE D DIRECTION
ME	8			MATRIX SIZE E DIRECTION
n	67			BALL COUNT
Øb	0.41	0.46	0.51	BALL DIAMETER
eE	0.80 BSC			BALL PITCH
eD	0.80 BSC			BALL PITCH
SD	0.40 BSC			SOLDER BALL PLACEMENT
SE	0.40 BSC			SOLDER BALL PLACEMENT
	A1,D1,E1,F1,G1 A4,K4,A5,K5 D8,E8,F8,G8			DEPOPULATED SOLDER BALLS

NOTES:

- DIMENSIONING AND TOLERANCING METHODS PER ASME Y14.5M-1994.
- ALL DIMENSIONS ARE IN MILLIMETERS.
- BALL POSITION DESIGNATION PER JEP95, SECTION 3, SPP-020.
- [e] REPRESENTS THE SOLDER BALL GRID PITCH.
- SYMBOL "MD" IS THE BALL MATRIX SIZE IN THE "D" DIRECTION. SYMBOL "ME" IS THE BALL MATRIX SIZE IN THE "E" DIRECTION. n IS THE NUMBER OF POPULATED SOLDER BALL POSITIONS FOR MATRIX SIZE MD X ME.
- [6] DIMENSION "b" IS MEASURED AT THE MAXIMUM BALL DIAMETER IN A PLANE PARALLEL TO DATUM C.
- [7] "SD" AND "SE" ARE MEASURED WITH RESPECT TO DATUMS A AND B AND DEFINE THE POSITION OF THE CENTER SOLDER BALL IN THE OUTER ROW.
WHEN THERE IS AN ODD NUMBER OF SOLDER BALLS IN THE OUTER ROW, "SD" OR "SE" = 0.
WHEN THERE IS AN EVEN NUMBER OF SOLDER BALLS IN THE OUTER ROW, "SD" = eD/2 AND "SE" = eE/2.
- "+" INDICATES THE THEORETICAL CENTER OF DEPOPULATED BALLS.
- [9] A1 CORNER TO BE IDENTIFIED BY CHAMFER, LASER OR INK MARK, METALLIZED MARK INDENTATION OR OTHER MEANS.

g5019 \ f16-038.25 \ 10.11.13

8. System Interface

To simplify system interface, CE# may be unasserted during data loading or sequential data reading as shown in [Figure 8.1](#). By operating in this way, it is possible to connect NAND flash to a microprocessor.

Figure 8.1 Program Operation with CE# Don't Care

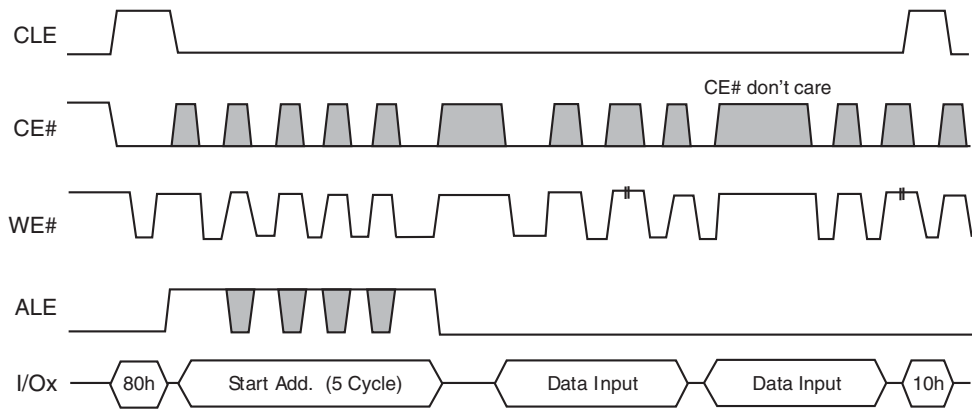

Figure 8.2 Read Operation with CE# Don't Care

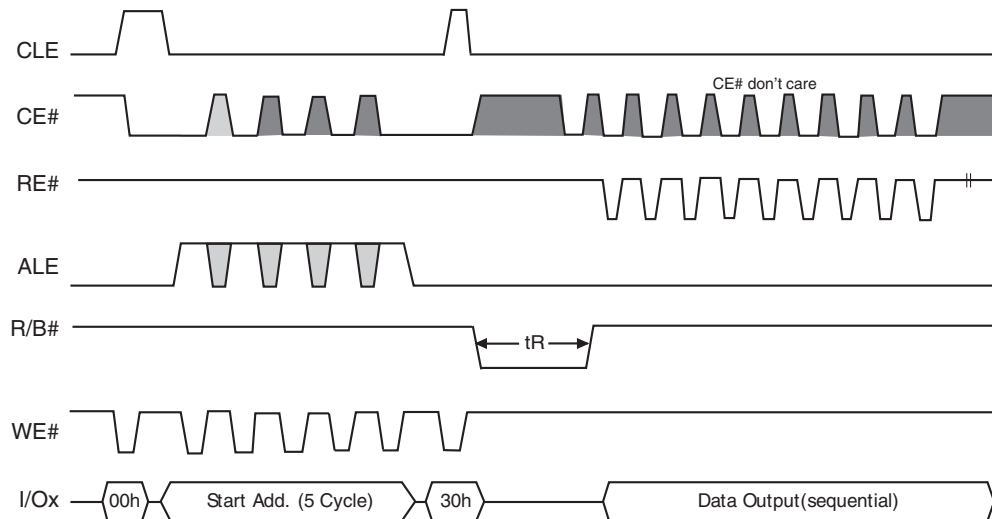
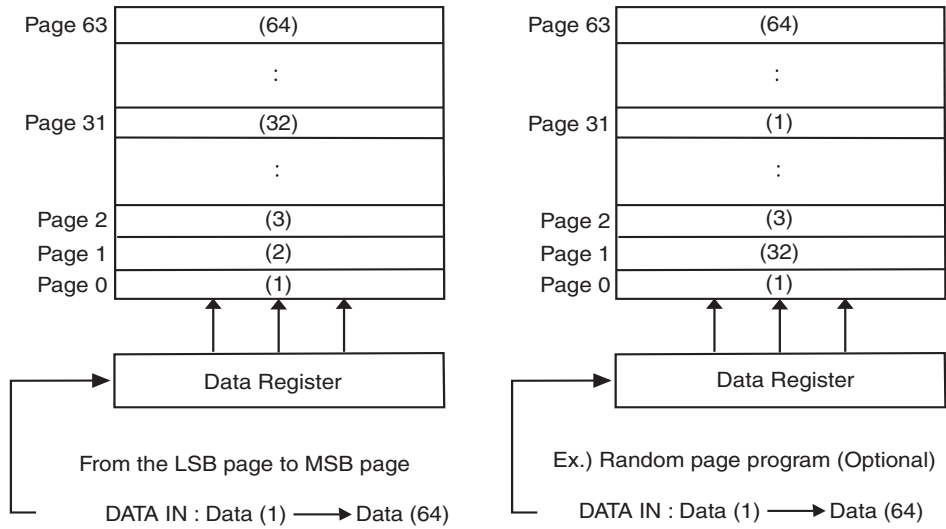

Figure 8.3 Page Programming Within a Block



9. Error Management

9.1 System Bad Block Replacement

Over the lifetime of the device, additional Bad Blocks may develop. In this case, each bad block has to be replaced by copying any valid data to a new block. These additional Bad Blocks can be identified whenever a program or erase operation reports “Fail” in the Status Register.

The failure of a page program operation does not affect the data in other pages in the same block, thus the block can be replaced by re-programming the current data and copying the rest of the replaced block to an available valid block. Refer to [Table 9.1](#) and [Figure 9.1](#) for the recommended procedure to follow if an error occurs during an operation.

Table 9.1 Block Failure

Operation	Recommended Procedure
Erase	Block Replacement
Program	Block Replacement
Read	ECC (4 bit / 512+16 byte)

Figure 9.1 Bad Block Replacement

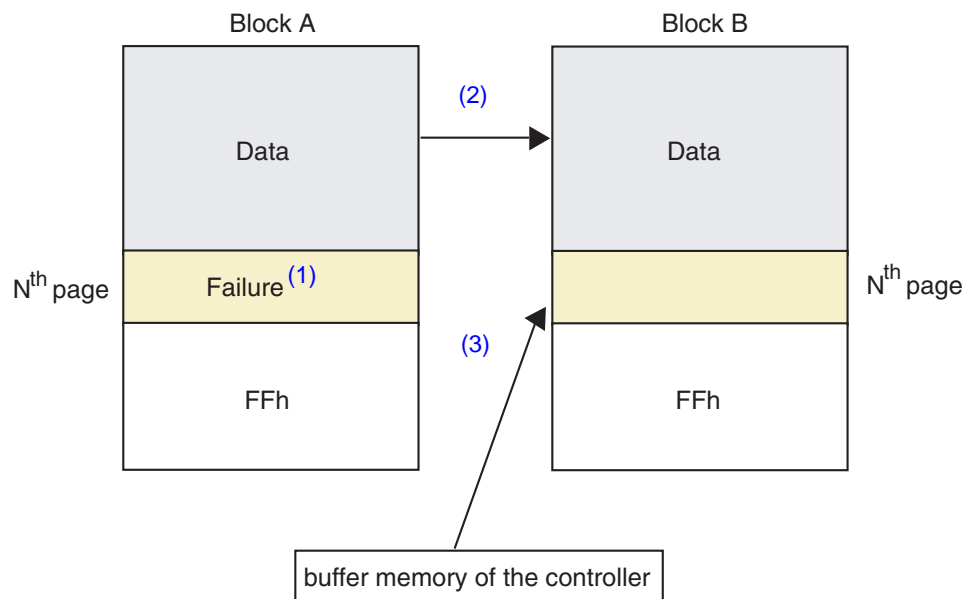

Notes:

1. An error occurs on the Nth page of Block A during a program operation.
2. Data in Block A is copied to the same location in Block B, which is a valid block.
3. The Nth page of block A, which is in controller buffer memory, is copied into the Nth page of Block B.
4. Bad block table should be updated to prevent from erasing or programming Block A.

9.2 Bad Block Management

Devices with Bad Blocks have the same quality level and the same AC and DC characteristics as devices where all the blocks are valid. A Bad Block does not affect the performance of valid blocks because it is isolated from the bit line and common source line by a select transistor. The devices are supplied with all the locations inside valid blocks erased (FFh). The Bad Block Information is written prior to shipping. Any block where the 1st byte in the spare area of the 1st or 2nd or last page does not contain FFh is a Bad Block. That is, if the first page has an FF value and should have been a non-FF value, then the non-FF value in the second page or the last page will indicate a bad block. The Bad Block Information must be read before any erase is attempted, as the Bad Block Information may be erased. For the system to be able to recognize the Bad Blocks based on the original information, it is recommended to create a Bad Block table following the flowchart shown in Figure 9.2. The host is responsible to detect and track bad blocks, both factory bad blocks and blocks that may go bad during operation. Once a block is found to be bad, data should not be written to that block. The 1st block, which is placed on 00h block address is guaranteed to be a valid block.

Figure 9.2 Bad Block Management Flowchart

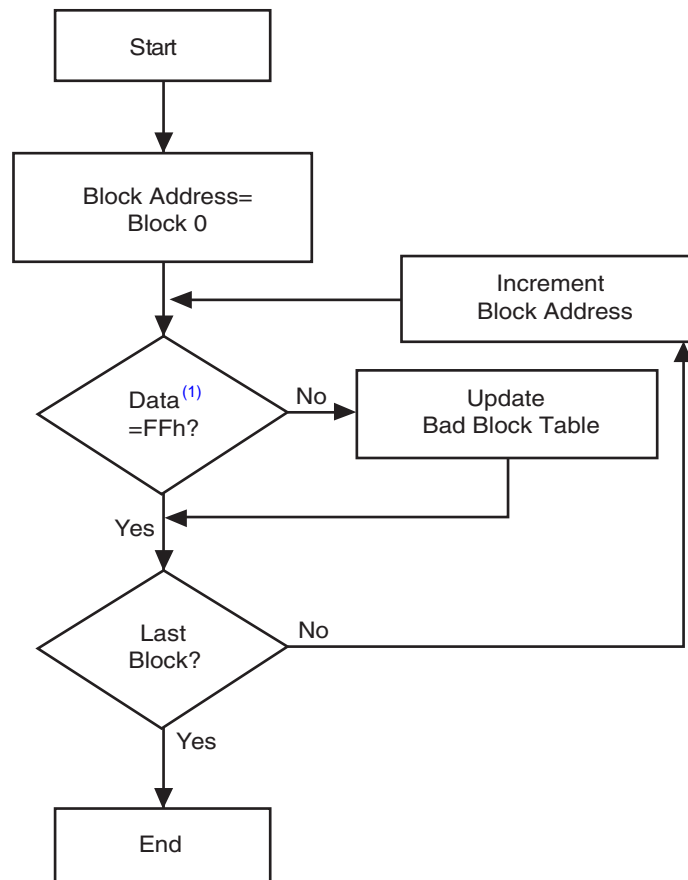

Note:

1. Check for FFh at the 1st byte in the spare area of the 1st, 2nd, and last pages.

10. Ordering Information

The ordering part number is formed by a valid combination of the following:

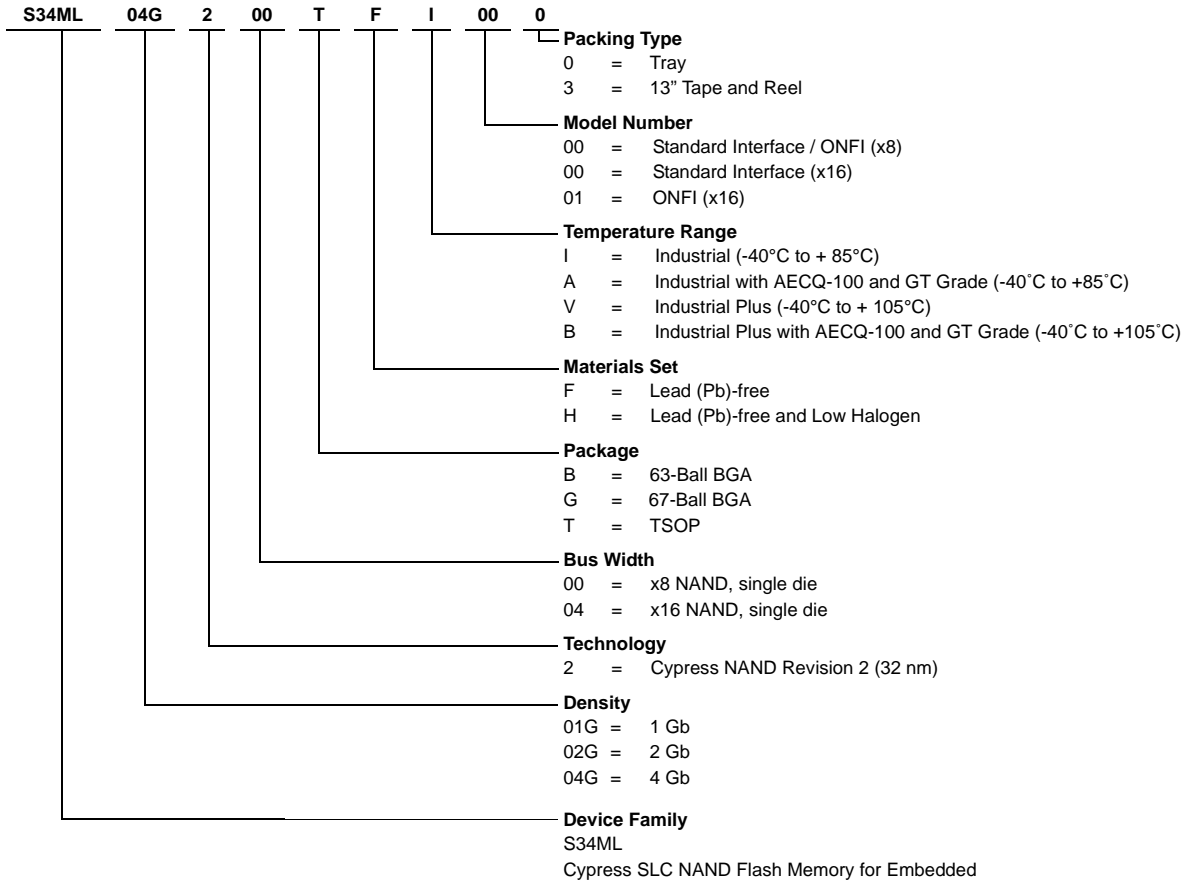

Valid Combinations

Valid Combinations list configurations planned to be supported in volume for this device. Consult your local sales office to confirm availability of specific valid combinations and to check on newly released combinations.

Device Family	Density	Technology	Bus Width	Package Type	Temperature Range	Additional Ordering Options	Packing Type	Package Description
S34ML	01G	2	04	TF	I	00, 01 Unique ID Support guaranteed: 90 _ Standard Interface / ONFI 1.0 (x8) 91 _ ONFI 1.0 (x16)	0, 3	TSOP, BGA (1)
	01G		00	BH, GH, TF	I, A, V, B			
	02G		04	TF	I			
	02G		00	BH, GH, TF	I, A, V, B(2)			
	04G		00	BH, TF	I, A, V, B			
	04G		04	BH	I			

Notes:

- BGA package marking omits the leading "S34" and the Packing Type designator from the ordering part number.
- Contact sales regarding the availability of S34ML02G2 products in A, V and B temperature ranges.

11. Document History

Document Title: S34ML01G2, S34ML02G2, S34ML04G2 1 Gb, 2 Gb, 4 Gb, 3 V, 4-bit ECC, SLC NAND Flash Memory for Embedded Document Number: 002-00499				
Rev.	ECN No.	Orig. of Change	Submission Date	Description of Change
**	-	XILA	08/03/2012	Initial release
*A	-	XILA	11/27/2012	<p>Global: Upgraded data sheet designation from Advance Information to Preliminary Note the S34ML02G2 is in the Advance Information designation Added x16 I/O bus width data</p> <p>Performance Reliability: changed “with 1 bit ECC” to “with 4 bit ECC”</p> <p>Connection Diagram: Added 63-VFBGA Contact, x16 Device (Balls Down, Top View) figure</p> <p>Array Organization : Added Array Organization — x16 figure</p> <p>Addressing: Address Cycle Map 1G/2G/4G Device tables: added x16 data</p> <p>Multiplane Program — S34ML02G2 and S34ML04G2 Added text</p> <p>Multiplane Block Erase — S34ML02G2 and S34ML04G2 Added text</p> <p>Multiplane Copy Back Program —S34ML02G2 and S34ML04G2 Added text</p> <p>Read ID Read ID for Supported Configurations table: corrected x8 information Added x16 information: Read ID for Supported Configurations table Read ID Byte 4 Description — S34ML01G2 table Read ID Byte 4 Description — S34ML02G2 and S34ML04G2</p> <p>Read Parameter Page Parameter Page Description table: updated values for Bytes 254-255 Absolute Maximum Ratings Absolute Maximum Ratings table: updated Input or Output Voltage, and Supply Voltage values added note</p> <p>AC Characteristics AC Characteristics table: added CE# access time added note for tCOH and tRHOH</p>

11. Document History (Continued)

Document Title: S34ML01G2, S34ML02G2, S34ML04G2 1 Gb, 2 Gb, 4 Gb, 3 V, 4-bit ECC, SLC NAND Flash Memory for Embedded Document Number: 002-00499				
Rev.	ECN No.	Orig. of Change	Submission Date	Description of Change
*A	-	XILA	11/27/2012	<p>Multiplane Page Program Operation —S34ML02G2 and S34ML04G2 Added note to Multiplane Page Program figure Added note to Multiplane Page Program (ONFI 1.0 Protocol) figure</p> <p>Multiplane Block Erase — S34ML02G2 and S34ML04G2 Added note to Multiplane Block Erase figure Added note to Multiplane Block Erase (ONFI 1.0 Protocol) figure</p> <p>Multiplane Copy Back Program —S34ML02G2 and S34ML04G2 Added note to Multiplane Copy Back Program figure Multiplane Copy Back Program (ONFI 1.0 Protocol) figure: Changed IOx values Updated notes</p> <p>Error Management :Block Failure table: Changed ECC 1 bit to 4 bit</p> <p>Multiplane Cache Program —S34ML02G2 and S34ML04G2 Multiplane Cache Program figure: Removed A13-A31 Address Input values Added note</p> <p>Ordering Information : Added x16 Model Numbers</p>
*B	-	XILA	12/19/2012	<p>Command Set Added Page Reprogram command Reorganized Command Set table</p> <p>Page Reprogram Moved section Added paragraph</p> <p>Copy Back Program :Added paragraph</p> <p>Reset: Updated paragraph Read ID2: Added text</p> <p>Read Parameter Page Parameter Page Description table: fixed Values of Bytes 6-7 and 254-255 fixed Description of Bytes 129-130 and 131-132 Absolute Maximum Ratings Fixed Value for VIO and VCC</p> <p>DC Characteristics DC Characteristics and Operating Conditions table: Changed Power On Current Test Conditions and Typ/Max values</p> <p>AC Characteristics AC Characteristics table: added note</p> <p>Page Read Operation Page Read Operation (Read One Page) figure: added note</p> <p>Read ID2 Operation Timing Read ID2 Operation Timing figure: replaced t_{WHR} with t_R and added R/B# timing signal added note</p> <p>Bad Block Management Added text Bad Block Management Flowchart: updated note</p>

11. Document History (Continued)

Document Title: S34ML01G2, S34ML02G2, S34ML04G2 1 Gb, 2 Gb, 4 Gb, 3 V, 4-bit ECC, SLC NAND Flash Memory for Embedded Document Number: 002-00499				
Rev.	ECN No.	Orig. of Change	Submission Date	Description of Change
*C	XILA	-	02/14/2013	<p>Distinctive Characteristics: Corrected Plane Size for x16 Page Program Added paragraph Multiplane Program — S34ML02G2 and S34ML04G2 Added paragraph Page Reprogram: Added paragraph Block Erase Added paragraph Multiplane Block Erase — S34ML02G2 and S34ML04G2 Added paragraph Copy Back Program Added paragraph Multiplane Copy Back Program — S34ML02G2 and S34ML04G2 Added paragraph Multiplane Cache Program — S34ML02G2 and S34ML04G2 Added paragraph Read Parameter Page Added paragraphs Parameter Page Description table: corrected value for bytes 129-130, 131-132, and 254-255 Valid Blocks Updated table AC Characteristics AC Characteristics table: corrected Min value for t_{ALS}, t_{CLS}, and t_{DS} corrected Max value for t_{CEA}</p>
*D	-	XILA	06/19/2013	<p>Distinctive Characteristics Operating Temperature: removed Commercial and Extended temperatures Performance Updated Page Read / Program and Reliability sections General Description Updated section Block Diagram Updated Functional Block Diagram figure Array Organization Updated figures Added two figures: Array Organization — S34ML02G2 and S34ML04G2 (x8) Array Organization — S34ML02G2 and S34ML04G2 (x16) Addressing Appended Note in all Address Cycle Map tables Added text to Bus Cycle column in all Address Cycle Map tables Page Read Updated section Page Program Updated section Multiplane Program — S34ML02G2 and S34ML04G2 Updated section Page Reprogram Corrected Page Reprogram figure Corrected Page Reprogram with Data Manipulation figure Copy Back Program Updated section Read Status Register Field Definition Updated Status Register Coding table</p>

11. Document History (Continued)

Document Title: S34ML01G2, S34ML02G2, S34ML04G2 1 Gb, 2 Gb, 4 Gb, 3 V, 4-bit ECC, SLC NAND Flash Memory for Embedded Document Number: 002-00499				
Rev.	ECN No.	Orig. of Change	Submission Date	Description of Change
*D	-	XILA	06/19/2013	<p>Read ID Read ID for Supported Configurations table: corrected 2nd cycle for 1 Gb x16 Read ID Byte 5 Description — S34ML02G2 and S34ML04G2 table: corrected Description for Plane Size</p> <p>Read Parameter Page Parameter Page Description table: corrected value for bytes 8-9, 114, 137-138, 139-140, and 254-255</p> <p>Read Unique ID Added section</p> <p>Ready/Busy Updated section Updated Ready/Busy Pin Electrical Application figure</p> <p>Electrical Characteristics Absolute Maximum Ratings table: removed Ambient Operating Temperature (Commercial Temperature Range) and Ambient Operating Temperature (Extended Temperature Range)</p> <p>AC Characteristics AC Characteristics table: updated 'Data transfer from cell to register' Parameter</p> <p>Program / Erase Characteristics Program / Erase Characteristics table: added Dummy Busy Time for Multiplane Program(S34MS02G2, S34MS04G2)</p> <p>Multiplane Page Program Operation —S34MS02G2 and S34MS04G2 Updated Multiplane Page Program figure Updated Multiplane Page Program (ONFI 1.0 Protocol) figure</p> <p>Copy Back Read with Optional Data Readout Corrected Copy Back Read with Optional Data Readout figure</p> <p>Copy Back Program Operation With Random Data Input Corrected Copy Back Program Operation With Random Data Input figure</p> <p>Read Status Register Timing : Removed Read Status Enhanced Cycle figure</p> <p>Read Status Enhanced Timing: Removed Read Status Timing figure</p> <p>Read Cache Corrected Read Cache Operation Timing figure Removed Cache Timing heading</p> <p>Cache Program: Updated Cache Program figure</p> <p>Read Parameter Page Timing Added Note to Read Parameter Page Timing figure</p> <p>Read Unique ID Timing Added section</p> <p>Read Parameter Page Timing Added Note to Read Parameter Page Timing figure</p>

11. Document History (Continued)

Document Title: S34ML01G2, S34ML02G2, S34ML04G2 1 Gb, 2 Gb, 4 Gb, 3 V, 4-bit ECC, SLC NAND Flash Memory for Embedded Document Number: 002-00499				
Rev.	ECN No.	Orig. of Change	Submission Date	Description of Change
*D	-	XILA	06/19/2013	Read Unique ID Timing Added section Physical Interface Updated figures: TS/TSR 48 — 48-lead Plastic Thin Small Outline, 12 x 20 mm, Package Outline VBM063 — 63-Pin BGA, 11 mm x 9 mm Package Ordering Information Clarified Bus Width and Technology Added Note to Valid Combinations table
*E	-	XILA	08/09/2013	Mode Selection: Changed 'Busy Time in Read' WE# from X to High System Interface: Updated paragraph Updated Read Operation with CE# Don't Care figure
*F	-	XILA	11/01/2013	Performance Package Options: added 67-Ball BGA 8 x 6 x 1 mm Connection Diagram :Added figure: 67-BGA Contact (Balls Down, Top View) Physical Diagram : Added figure: 67-Ball, Ball Grid Array (BGA) Ordering Information: Added to 'Package' Valid Combinations Added 'GH' to Package Type Added 'Unique ID support guaranteed' to Additional Ordering Options
*G	-	XILA	01/06/2014	Global Upgraded data sheet designation from Preliminary to Full Production Note the S34ML02G2 is in the Advance Information designation
*H	-	XILA	07/03/2014	Ordering Information Added A, V, B to Temperature Range Valid Combinations table: added A to Temperature Range of 01G Density
*I	-	XILA	09/05/2014	Ordering Information Valid Combinations table: added Package Type BH and TF for 01G Density corrected Package Type for 02G Density
*J	-	XILA	04/17/2015	Distinctive Characteristics Operating Temperature: added Industrial Plus Read Parameter :Page Updated Note Read Unique ID (Contact Factory): Unique ID Data Description (Contact Factory) table: added Note Ordering Information: Valid Combinations table: updated table
*K	5030732	XILA	12/02/2015	Updated to Cypress template

11. Document History (Continued)

Document Title: S34ML01G2, S34ML02G2, S34ML04G2 1 Gb, 2 Gb, 4 Gb, 3 V, 4-bit ECC, SLC NAND Flash Memory for Embedded Document Number: 002-00499				
Rev.	ECN No.	Orig. of Change	Submission Date	Description of Change
*L	5160512	XILA	04/25/2016	Added Recommended Operating Conditions section. Updated DC Characteristics section - updated "VCC supply Voltage (erase and program lockout)" to "Erase and Program Lockout voltage". Updated Ordering Information. Updated "Read Parameter Page" section. Updated copyright information at the end of the document.
*M	5290473	XILA	05/31/2016	Updated the part numbers under Package Options in the 'Performance' section. Updated "Valid Combinations".

Sales, Solutions, and Legal Information

Worldwide Sales and Design Support

Cypress maintains a worldwide network of offices, solution centers, manufacturer's representatives, and distributors. To find the office closest to you, visit us at [Cypress Locations](#).

Products

ARM® Cortex® Microcontrollers	cypress.com/arm
Automotive	cypress.com/automotive
Clocks & Buffers	cypress.com/clocks
Interface	cypress.com/interface
Lighting & Power Control	cypress.com/powerpsoc
Memory	cypress.com/memory
PSoC	cypress.com/psoc
Touch Sensing	cypress.com/touch
USB Controllers	cypress.com/usb
Wireless/RF	cypress.com/wireless

PSoC® Solutions

cypress.com/psoc
PSoC 1 | PSoC 3 | PSoC 4 | PSoC 5LP

Cypress Developer Community

[Community](#) | [Forums](#) | [Blogs](#) | [Video](#) | [Training](#)

Technical Support

cypress.com/support

© Cypress Semiconductor Corporation 2012-2016. This document is the property of Cypress Semiconductor Corporation and its subsidiaries, including Spansion LLC ("Cypress"). This document, including any software or firmware included or referenced in this document ("Software"), is owned by Cypress under the intellectual property laws and treaties of the United States and other countries worldwide. Cypress reserves all rights under such laws and treaties and does not, except as specifically stated in this paragraph, grant any license under its patents, copyrights, trademarks, or other intellectual property rights. If the Software is not accompanied by a license agreement and you do not otherwise have a written agreement with Cypress governing the use of the Software, then Cypress hereby grants you under its copyright rights in the Software, a personal, non-exclusive, nontransferable license (without the right to sublicense) (a) for Software provided in source code form, to modify and reproduce the Software solely for use with Cypress hardware products, only internally within your organization, and (b) to distribute the Software in binary code form externally to end users (either directly or indirectly through resellers and distributors), solely for use on Cypress hardware product units. Cypress also grants you a personal, non-exclusive, nontransferable, license (without the right to sublicense) under those claims of Cypress's patents that are infringed by the Software (as provided by Cypress, unmodified) to make, use, distribute, and import the Software solely to the minimum extent that is necessary for you to exercise your rights under the copyright license granted in the previous sentence. Any other use, reproduction, modification, translation, or compilation of the Software is prohibited.

CYPRESS MAKES NO WARRANTY OF ANY KIND, EXPRESS OR IMPLIED, WITH REGARD TO THIS DOCUMENT OR ANY SOFTWARE, INCLUDING, BUT NOT LIMITED TO, THE IMPLIED WARRANTIES OF MERCHANTABILITY AND FITNESS FOR A PARTICULAR PURPOSE. Cypress reserves the right to make changes to this document without further notice. Cypress does not assume any liability arising out of the application or use of any product or circuit described in this document. Any information provided in this document, including any sample design information or programming code, is provided only for reference purposes. It is the responsibility of the user of this document to properly design, program, and test the functionality and safety of any application made of this information and any resulting product. Cypress products are not designed, intended, or authorized for use as critical components in systems designed or intended for the operation of weapons, weapons systems, nuclear installations, life-support devices or systems, other medical devices or systems (including resuscitation equipment and surgical implants), pollution control or hazardous substances management, or other uses where the failure of the device or system could cause personal injury, death, or property damage ("Unintended Uses"). A critical component is any component of a device or system whose failure to perform can be reasonably expected to cause the failure of the device or system, or to affect its safety or effectiveness. Cypress is not liable, in whole or in part, and Company shall and hereby does release Cypress from any claim, damage, or other liability arising from or related to all Unintended Uses of Cypress products. Company shall indemnify and hold Cypress harmless from and against all claims, costs, damages, and other liabilities, including claims for personal injury or death, arising from or related to any Unintended Uses of Cypress products.

Cypress, the Cypress logo, Spansion, the Spansion logo, and combinations thereof, PSoC, CapSense, EZ-USB, F-RAM, and Traveo are trademarks or registered trademarks of Cypress in the United States and other countries. For a more complete list of Cypress trademarks, visit cypress.com. Other names and brands may be claimed as property of their respective owners.