

# Alphanumeric Index

Series	Type	Page
0409 (Hi-Inrush)	10A, One-pole Relay	488
0410	16A, One-pole Relay	491
0429 (Hi-Inrush)	10A, One-pole Relay	457
0430	10-16A, One- or Two-pole Relay	495
600	3-15A, One-pole Relay	497
Card E (V23057)	8A, One-pole Relay	480
IF (V23077)	16A, One-pole Relay	489
OJ/OJE	3-10A, One-pole Relay	422
OMI/OMIH	16A, One-pole Relay	458
OMI 2	5A, Two-pole Relay	460
OMIF	20A, One-pole Relay	466
OMIT	10A, One-pole Relay	464
ORWH	10A, One-pole Relay	438
OSA	3-5A, Two-pole Relay	470
OSZ	16A, One-pole Relay	472
UDH	10A, One-pole Relay	432
OZ/OZF	16A, One-pole Relay	462
PB	10A, One-pole Relay	426
PCD/PCDF	15A, One-pole Relay	424
PCE	10A, One-pole Relay	436
PCG	5A, Two-pole Relay	493
PCH	5-10A, One-pole Relay	418
PCI	3A, Two-pole Relay	468
PCJ	5A, One-pole Relay	416
PCK	16A, One-pole Relay	478
PCN	3A, One-pole Relay	407
PE	5A, One-pole Relay	403
RE	6A, One-pole Relay	405
RP II/1	8-16A, One-pole Relay	484
RP II/2	8A, Two-pole Relay	482
RP3SL (Hi-Inrush)	16A, One-pole Relay	486
RT - AC Coil	8-16A, One- or two-pole Relay	448
RT - DC Coil	8-16A, One- or two-pole Relay	446
RT - Sensitive	10A, One-pole Relay	451
RT - Hi-Inrush	16A, One-pole Relay	455
RT - Hi-Temp	10-16A, One-pole Relay	453
RY II	8A, One-pole Relay	412
SDT	10A, One-pole Relay	474
SDT-R	5-10A, One-pole Relay	476
SNR (V23092)	6A, One-pole Relay	409
SRUDH	12A, One-pole Relay	442
SRUUH	15A, One-pole Relay	444
T7C	5-12A, One-pole Relay	440
T7N	10A, One-pole Relay	434
T73	10A, One-pole Relay	430
T75	8-14A, One-pole Relay	414
T77	3-10A, One-pole Relay	420
U/UB (V23148)	7A, One-pole Relay	428
V23057 (Card E)	8A, One-pole Relay	480
V23077 (IF)	16A, One-pole Relay	489
V23092 (SNR)	6A, One-pole Relay	409
V23148 (U/UB)	7A, One-pole Relay	428

**NOTE:** A question tree that may help you in selecting an appropriate relay for your application can be found on the next page.

## Mid-Range PC Board Relays .... 401-498

**4**

**NOTE:** In addition to the products listed in this section of the databook, 3-20A relays described in other sections are available with printed circuit board terminals. Following is a list:

### Relays with Forcibly Guided Contacts

SR4 D/M	606
SR6 D/M	607
SR6S	611
V23047 (SR2M)	603
V23050 (SR6)	609

### Plug-in/Panel Mount Relays

K10	720
KH	709
KU	723
PCL/PCLH	713
PT	717
R10	703
RM	733

### Power Relays & Contactors

KUHP	803
------	-----

### Latching, Impulse, Rotary & Special Application Relays

KUL	908
PCKWK	904
PE - Latching	902
RT - Latching	906

### Solid State Relays & I/O Modules

OAC/ODC	1110
OACM/ODCM	1118

Products in our line of high performance relays (see overview in section 14 of this databook) are also offered with PC terminals.

# Mid Range (3-20A) PC Board Relay Question Tree

This guide helps the user select one or more relay series which may be appropriate for a given application. The user should then refer to detailed specifications elsewhere in this catalog to determine the actual part number to be specified. Of course, the user must assume ultimate responsibility for determining the suitability of a relay for a particular application.

Several relay product families are quite broad (i.e., RT), and only the basic family designator, not the actual product series designator (RT-Sensitive) is listed in this guide.

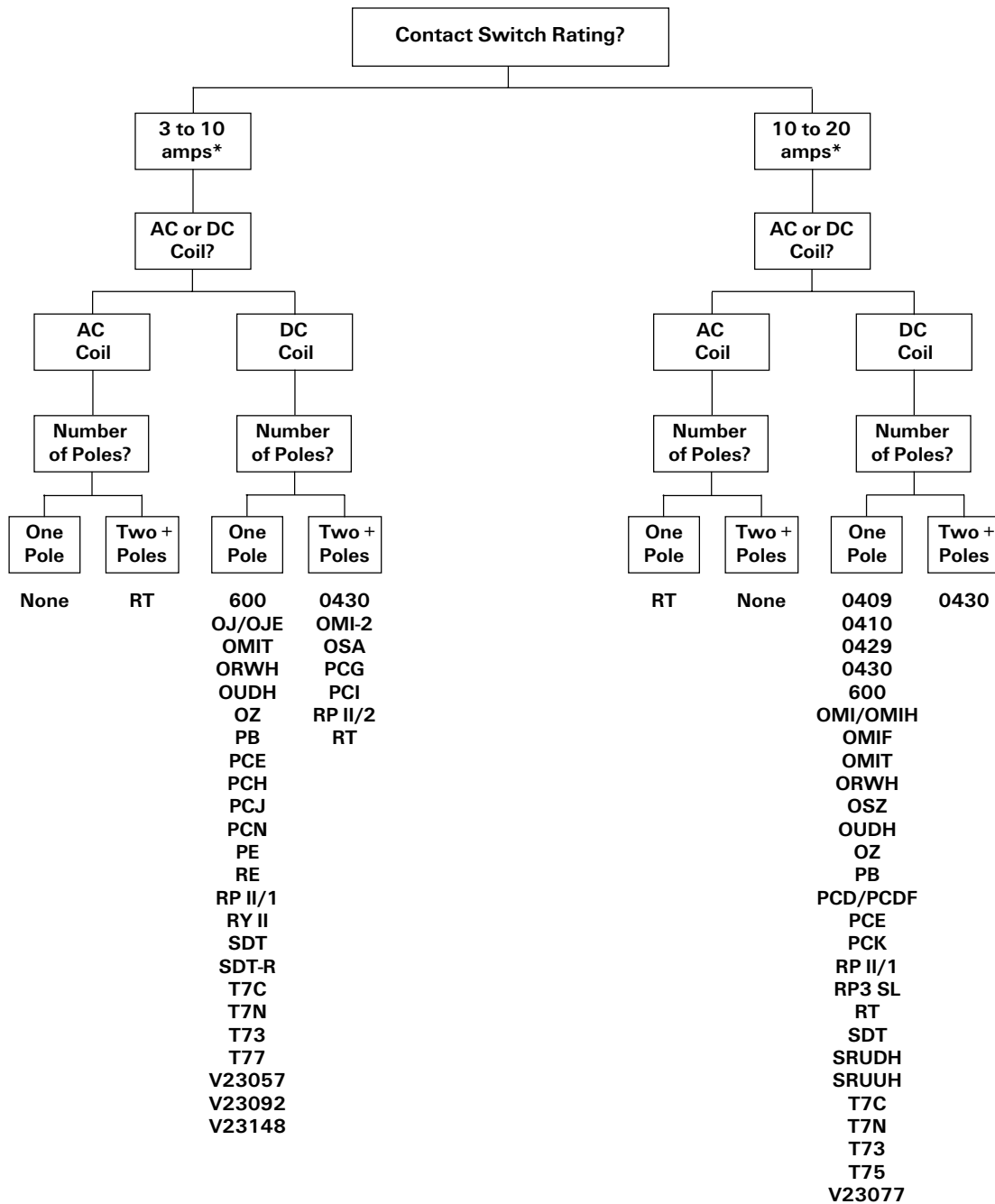

\* Typical loads at 28VDC or 120VAC, resistive, for comparison purposes. See catalog pages for a given series for detailed rating specifications.



# PE series

## 5 Amp Miniature Printed Circuit Board Relay

UL File E214025

VDE File 6656UG

Users should thoroughly review the technical data before selecting a product part number. It is recommended that users also seek out the pertinent approvals files of the agencies/laboratories and review them to ensure the product meets the requirements for a given application.

### Features

- 1 Form C (SPDT).
- 5 amp rated current.
- Sensitive coil 200mW.
- 10mm height.
- Flux-tight for wave soldering.
- Supplied in tubes.
- DIP configuration.
- 4KV coil-to-contact insulation.
- Latching version available. See separate "PE Latching Series" data sheet.

### Contact Data @ 85°C

**Arrangement:** 1 Form C (SPDT).

**Material:** Silver-nickel 90/10.

**Expected Mechanical Life:** 15 million operations minimum.

**Ratings:** 5 amp 250VAC resistive 100,000 operations.

### Contact Life

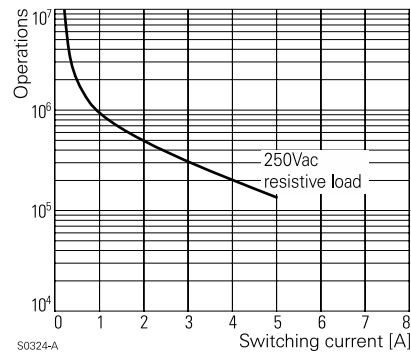

### Initial Dielectric Strength

**Between Open Contacts:** 1,000VAC.

**Between Coil and Contacts:** 4,000VAC.

**Creepage/Clearance Coil-Contact:** >3.2/4mm.

### Coil Data DC @ 20°C

**Nominal Coil Power:** 200mW.

Nominal Voltage VDC	DC Resistance in Ohms ±10%	Must Operate Voltage VDC	Drop-out Voltage VDC	Nominal Coil Current (mA)
05	125	3.8	0.5	40.0
06	172	4.5	0.6	34.9
12	685	9.0	1.2	17.5
24	2,725	18.0	2.4	8.8
48	10,970	36.0	4.8	4.4

### Max. DC Load Breaking Capacity

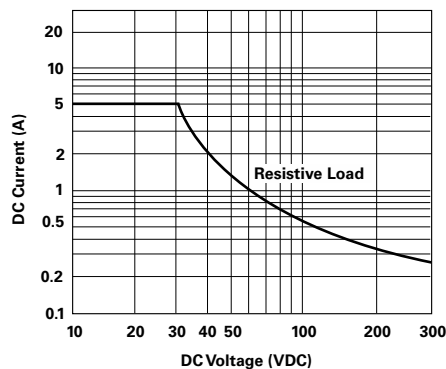

### Operate Data

**Must Operate Voltage:** See Coil Data table.

**Operate Time :** 5 ms typical, at nom. voltage.

**Release Time :** 2 ms typical, at nom. voltage.

**Bounce Time:** 1 ms typical, at nom. voltage (N/O contact);

5 ms typical, at nom. voltage (N/C contact).

**Switching Rate:** 360 ops./hr. max. at rated load.

### Environmental Data

**Temperature Range:**

**Operating:** -40°C to +85°C DC coil.

**Vibration (30 to 500 Hz.):** 15g N/O; 5g N/C.

**Shock (Destructive):** >100g.

### Mechanical Data

**Termination:** Printed circuit terminals.

**Enclosure (94 V-0 rated):** Flux-tight plastic case.

**Weight:** 0.18 oz. (5 g) approximately.

### Coil Operating Range

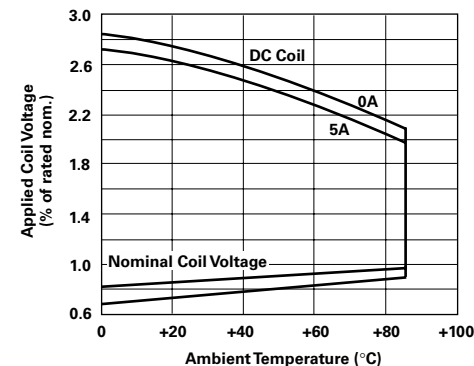

**Ordering Information**

Typical Part Number ▶

**PE**

**0**

**1**

**4**

**024**

**1. Basic Series:**

PE = Miniature printed circuit board relay.

**2. Enclosure\*:**

0 = Flux-tight.

**3. Contact Arrangement:**

1 = 1 Form C (SPDT)

**4. Contact Material:**

4 = Silver-nickel 90/10

**5. Coil Voltage:**

005 = 5VDC

012 = 12VDC

048 = 48VDC

006 = 6VDC

024 = 24VDC

\* Sealed version available on request.

**Our authorized distributors are more likely to maintain the following items in stock for immediate delivery.**

PE014005 PE014024  
PE014012

**Outline Dimensions**

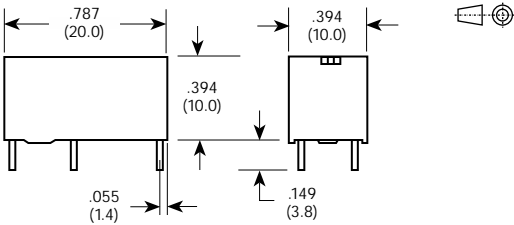

**Wiring Diagram (Bottom View)**

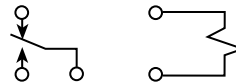

**PC Board Layout (Bottom View)**

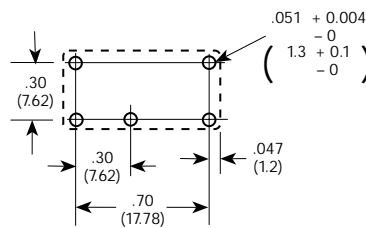



# RE series

## 6 Amp Miniature Printed Circuit Board Relay

- File E214025
- NR 10071
- NR 8841-014-02
- NR 10308.ZA1.A

Users should thoroughly review the technical data before selecting a product part number. It is recommended that users also seek out the pertinent approvals files of the agencies/laboratories and review them to ensure the product meets the requirements for a given application.

### Features

- 1 Form A (SPST-NO).
- 6 amp rated current.
- Sensitive coil 200 mW.
- 10.6mm height.
- Fully sealed with vent hole.
- Supplied in tubes.

### Contact Data @ 70°C

**Arrangements:** 1 Form A (SPST-NO).

**Material:** Silver-cadmium oxide.

Silver-nickel 0.15 with gold plating.

**Expected Mechanical Life:** 30 million operations minimum.

**Ratings:**

- 6 amp 30 VDC resistive load 500,000 ops.
- 0.3 amp 50 VDC L/R = 40ms 3,000,000 ops.

#### UL/CSA AgCdO @ 25°C

- 6 amp 250VAC general purpose 30,000 ops.
- 10 amp 120VAC general purpose (+70°C) 6,000 ops.
- 1/4 HP 240VAC 30,000 ops.
- 1/6 HP 277VAC 30,000 ops.
- 1/8 HP 120VAC 30,000 ops.
- B300 6,000 ops.

#### UL/CSA AgNi 0.15 @ 70°C

- 6 amp 250VAC general purpose 6,000 ops.

#### VDE 0435 @ 70°C

- 6 amp 250VAC general purpose 100,000 ops.
- 10mA 5VDC 5,000,000 ops.

#### VDE 0660 AC 11 @ 35°C

- 2 amp 400VAC 200,000 ops.

### Initial Dielectric Strength

**Between Open Contacts:** 1,000VAC.

**Between Coil and Contacts:** 4,000VAC.

**Creepage/Clearance Coil-Contact:** 4/4mm.

### Coil Data DC @ 20°C

**Nominal Coil Power:** 200mW.

Nominal Voltage VDC	DC Resistance in Ohms ±10%	Must Operate Voltage VDC	Drop-out Voltage VDC	Nominal Coil Current (mA)
05	125±10%	3.5	0.5	40
06	180±10%	4.2	0.6	33.3
12	720±10%	8.4	1.2	16.7
24	2,880±15%	16.8	2.4	8.3
48	11,520±15%	33.3	4.8	4.2

### Operate Data

**Must Operate Voltage:** See Coil Data table.

**Operate Time :** 5 ms typical, at nom. voltage.

**Release Time :** 1 ms typical, at nom. voltage.

**Bounce Time:** 1 ms typical, at nom. voltage.

**Switching Rate:** 360 ops./hr. max. at rated load.  
12,000

### Environmental Data

**Temperature Range:**

**Operating:** -40°C to +70°C. (+85°C @ 4 amp).

**Vibration:** 10 to 150 Hz, at 10g N/O 20g N/C.

**Shock (destructive):** >100g.

### Mechanical Data

**Termination:** Printed circuit terminals.

**Enclosure (94 V-0 rated):** Sealed (RTIII) plastic case.

**Weight:** 0.18 oz. (5 g) approximately.

### Contact Life

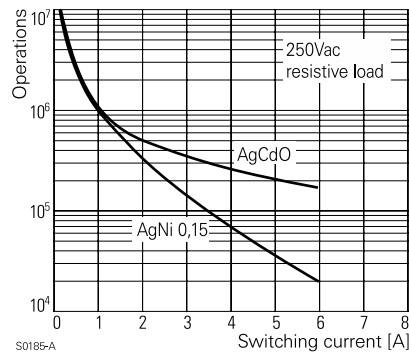

### Max. DC Load Breaking Capacity

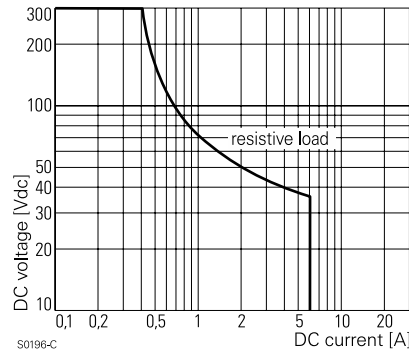

### Coil Operating Range

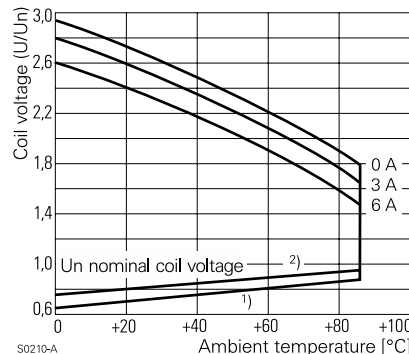

Dimensions are shown for reference purposes only.

Dimensions are in inches over (millimeters) unless otherwise specified.

Specifications and availability subject to change.

www.tycoelectronics.com  
Technical support:  
Refer to inside back cover.

**Ordering Information**

<b>Typical Part Number ▶</b>			<b>RE</b>	<b>0</b>	<b>3</b>	<b>0</b>	<b>006</b>
<b>1. Basic Series:</b> RE = Miniature printed circuit board relay.							
<b>2. Enclosure:</b> 0 = Sealed							
<b>3. Contact Arrangement:</b> 3 = 1 Form A (SPST-NO)							
<b>4. Contact Material:</b> 0 = Silver-cadmium oxide. 2 = Silver-nickel 0.15 with gold plating.							
<b>5. Coil Voltage:</b>							
005 = 5VDC	012 = 12VDC	048 = 48VDC					
006 = 6VDC	024 = 24VDC						

**Our authorized distributors are more likely to maintain the following items in stock for immediate delivery.**

RE030005 RE030024  
RE030012

**Outline Dimensions**

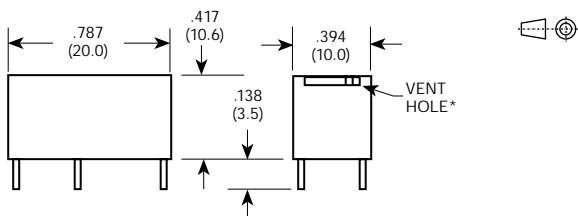

**Wiring Diagram (Bottom View)**

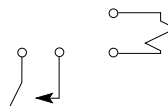

In case of full load on contacts and under extreme operating conditions (switching rate, ambient temperature) it is recommended to open the sealed (washable) relays, by opening the vent hole\* provided for this purpose, after completion of the cleaning process.

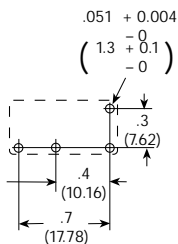

**PC Board Layout (Bottom View)**





# PCN series

## Slim, 3 Amp PC Board Relay

 File No. E82292  
 File 6166

Users should thoroughly review the technical data before selecting a product part number. It is recommended that user also seek out the pertinent approvals files of the agencies/laboratories and review them to ensure the product meets the requirements for a given application.

### Features

- Only 5 mm wide, permitting high density spacing.
- 1 Form A contact arrangement.
- Sensitive coil requires only 120mW coil power.
- Well suited for HVAC controls, I/O panels, PLCs.

### Contact Data @ 20°C

**Arrangements:** 1 Form A.  
**Type:** Bifurcated.  
**Material:** AgNi  
**Max. Switching Rate:** 12,000 ops./min. (no load).  
100 ops./min. (rated load).  
**Expected Mechanical Life:** 20 million operations (no load).  
**Expected Electrical Life:** 100,000 operations (rated load).  
**Minimum Load:** 1mA @ 5VDC.

### Contact Ratings

**Ratings:** 3A @ 250VAC resistive.  
3A @ 30VDC resistive.  
**Max. Switched Voltage:** AC: 277V; DC: 125V.  
**Rated Switched Voltage:** AC: 250V.  
**Max. Switched Current:** 3A.  
**Max. Switched Power:** AC: 1250VA; DC: 150W.  
**Initial Contact Resistance:** 50 milliohms @ 100mA, 6VDC (reference).

**NOTE:** A 5A rated version of the PCN series is now in development. Consult factory regarding its availability.

### Insulation Data

**Insulation to IEC 664/VDE 0110**  
**Voltage Rating:** 277VAC.  
**Pollution Degree:** 2.  
**Overvoltage Category:** II.  
**Tracking Resistance of Relay Base:** PTI 600.

### Initial Dielectric Strength

**Between Open Contacts:** 750Vrms.  
**Between Coil and Contacts:** 3,000Vrms.  
**Surge Voltage Between Coil and Contacts:** 5,080V (1.2 / 50µs).

### Coil Data

**Voltage:** 5 to 24VDC.  
**Nominal Power:** 120mW.  
**Operate Power:** 58.8mW.  
**Coil Temperature Rise:** 35°C max., at rated coil voltage.  
**Max. Coil Voltage:** 130% of nominal.  
**Duty Cycle:** Continuous.

### Coil Data @ 20°C

Rated Coil Voltage (VDC)	Nominal Current (mA)	PCN		
		Coil Resistance (ohms) ± 10%	Must Operate Voltage (VDC)	Must Release Voltage (VDC)
5	24.0	208	3.5	0.5
6	20.0	300	4.2	0.6
9	13.3	675	6.3	0.9
12	10.0	1,200	8.4	1.2
24	5.0	4,800	16.8	2.4

### Operate Data

**Must Operate Voltage:** 70% of nominal voltage or less.  
**Must Release Voltage:** 10% of nominal voltage or more.  
**Operate Time:** 5 ms typ.  
**Release Time:** 2 ms typ.  
**Bounce Time:** <1 ms typ.

### Environmental Data

**Temperature Range:**  
**Operating:** -40°C to +70°C  
**Vibration, Mechanical:** 10 to 55Hz., 1.5mm double amplitude.  
**Operational:** 10 to 55Hz., 1.5mm double amplitude.  
**Shock, Mechanical:** 1,000m/s<sup>2</sup> (100G approximately).  
**Operational:** 100m/s<sup>2</sup> (10G approximately).  
**Operating Humidity:** 10 to 90% RH. (Non-condensing).

### Mechanical Data

**Termination:** Printed circuit terminals.  
**Enclosure (94V-0 Flammability Ratings):** Sealed (RT III / wash-tight) plastic case.  
**Weight:** 0.1 oz (3g) approximately.

**Ordering Information**

Typical Part Number ▶

**PCN -1 06 D 3 M H Z ,300**

**1. Basic Series:**

PCN = Slim 3A PC Board Relay

**2. Number of Poles:**

1 = 1 Pole

**3. Coil Voltage:**

05 = 5VDC    06 = 6VDC    09 = 9VDC    12 = 12VDC    18 = 18VDC    24 = 24VDC

**4. Coil Version:**

D = Standard 120mW

**5. Contact Material:**

3 = AgNi

**6. Contact Arrangement:**

M = 1 Form A, SPST-NO

**7. Enclosure Version:**

H = Sealed (wash-tight)

**8. Insulation:**

Z = High Insulation

**9. Suffix:**

,000 = Standard model

Other Suffix = Custom model

**Our authorized distributors are more likely to maintain the following items in stock for immediate delivery.**

None at present.

**Outline Dimensions**

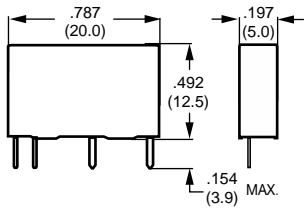

**Wiring Diagram**

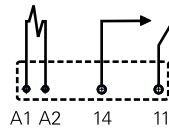

**PC Board Layout (Bottom View)**

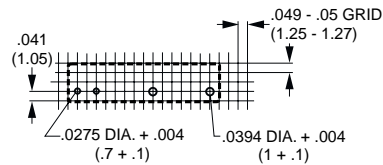

**Reference Data**

**Coil operating range DC**

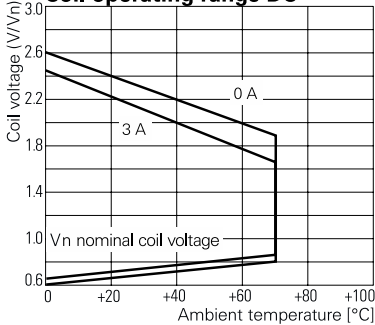

**Max. DC load breaking capacity**

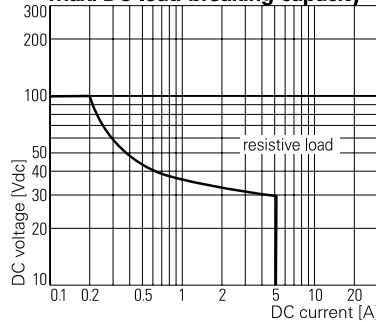

**Electrical endurance**

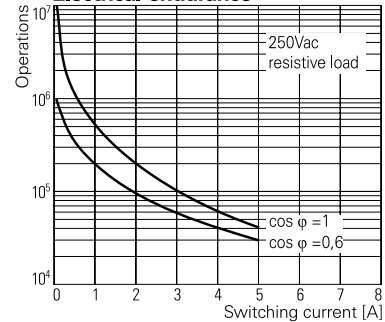



# V23092 (SNR) series

## 6 Amp Slim Miniature, PC Board Relay

File E48393

File 0631 / 0160 / 0435

Users should thoroughly review the technical data before selecting a product part number. It is recommended that user also seek out the pertinent approvals files of the agencies/laboratories and review them to ensure the product meets the requirements for a given application.

### Features

- 1 Form A (SPST-NO) and 1 Form C (SPDT).
- 6 A rated current.
- Slim package : 5mm width.
- Sensitive coil 170mW.
- 4kV coil-to-contact insulation.
- Applications: PLCs, timers, temperature controllers, I/O modules.

### Contact Data @ 20°C

**Arrangements:** 1 Form A (SPST-NO) and 1 Form C (SPDT).  
**Material:** Silver tin oxide, silver tin oxide with gold plating; and silver nickel 90/10.  
**Max. Switching Rate:** 12,000 ops./min. (no load).  
 60 ops./min. (rated load).  
**Initial Contact Resistance:**  
**AgSnO or AgNi 90/10:** 100 milliohms @ 1A, 12VDC.  
**AgSnO, Au plated:** 50 milliohms @ 100mA, 6VDC.  
**Max. Switched Voltage: AC:** 400V; **DC:** 300V.  
**Rated Voltage: AC:** 250V; **DC:** 24V.  
**Max. Switched Current:** 6A.  
**Max. Switched Power:** 1,500VA. (See curve for DC Power).  
**Minimum Load: AgSnO or AgNi 90/10:** >500mA, 12VAC/VDC.  
**AgSnO, Au plated:** >10mA, 5VAC/VDC.  
**Expected Mechanical Life:** 10 million operations.  
**Expected Electrical Life:** See curve.

### Initial Dielectric Strength

**Between Open Contacts:** 1,000VAC, (1 minute).  
**Between Contacts and Coil:** 4,000VAC, (1 minute).  
**Surge Voltage Between Coil and Contacts:** 6,000V (1.2/50µs).  
**Creepage/Clearance Coil-to-Contact:** Min. 6/8mm. Consult factory regarding availability of 1 Form A model with 8/8mm.

### Initial Insulation Resistance

**Between Mutually Insulated Conductors:** 100,000Mohm @ 500VDC.

### Coil Data @ 20°C

**Voltage:** 5 to 48VDC.  
**Nominal Power:** 170mW.

V23092				
Rated Coil Voltage (VDC)	Nominal Current (mA)	Coil Resistance (ohms) ± 10%	Must Operate Voltage (VDC)	Must Release Voltage (VDC)
5	34.0	119	3.50	0.25
12	14.2	848	8.40	0.6
24	7.1	3,390	16.80	1.20
48	4.5	10,600*	33.60	2.40

\* ± 15%

### Operate Data @ 20°C

**Must Operate Voltage:** 70% of nominal voltage or less.  
**Must Release Voltage:** 5% of nominal voltage or more.  
**Operate Time:** 5 ms max. at nominal voltage.  
**Release Time:** 2.5 ms max. at nominal voltage.  
**Bounce Time:** 1.5 ms (N/O) typical at nominal voltage.  
 5 ms (N/C) typical at nominal voltage.

### Environmental Data

**Temperature Range:**  
**Operating:** -40°C to +85°C.  
**Operating Humidity:** 20 to 85% RH.

### Mechanical Data

**Termination:** Printed circuit terminals.  
**Enclosure (94V-0 Flammability Ratings):** Plastic sealed case (RT III wash tight).  
**Weight:** 0.2 oz. (6g) approximately.

### Contact Life

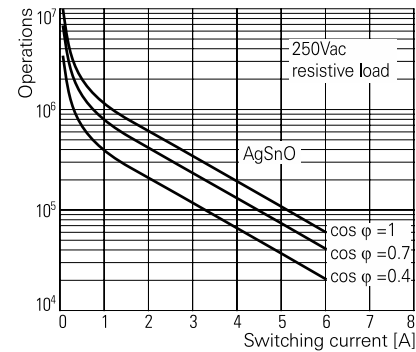

### Max. DC Load Breaking Capacity

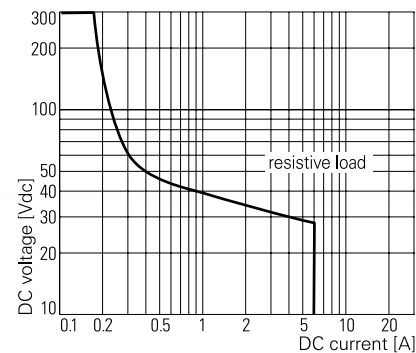

### Coil Operating Range

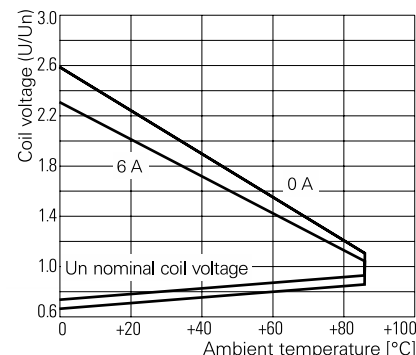

**Ordering Information**

<b>Typical Part Number ▶</b>		<b>V23092</b>	<b>A</b>	<b>1</b>	<b>024</b>	<b>A</b>	<b>3</b>	<b>01</b>
<b>1. Basic Series:</b> V23092 = Slim PC board relay.								
<b>2. Package Type:</b> A = PCB vertical version.      B = PCB flat pack version.								
<b>3. Enclosure:</b> 1 = Plastic sealed case.								
<b>4. Coil Input:</b> 005 = 5VDC      012 = 12VDC      024 = 24VDC      48 = 48VDC								
<b>5. Contact System:</b> A = Standard.								
<b>6. Contact Material:</b> 2 = AgSnO <sub>2</sub> , Au plated.      3 = AgSnO      8 = AgNi 90/10								
<b>7. Contact Arrangement:</b> 01 = 1 Form C (SPDT).      02 = 1 Form A (SPST-NO).								

**Our authorized distributors are more likely to maintain the following items in stock for immediate delivery.**

V23092A1012A301  
V23092A1024A301

**Outline Dimensions**

**Vertical Version**

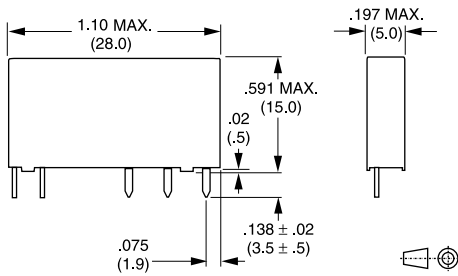

**Flat Pack Version**

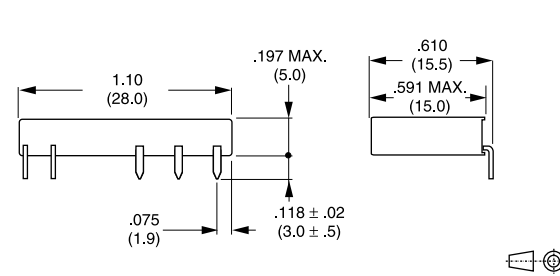

**Wiring Diagrams (Bottom Views)**

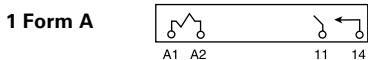

**PC Board Layout (Bottom View)**

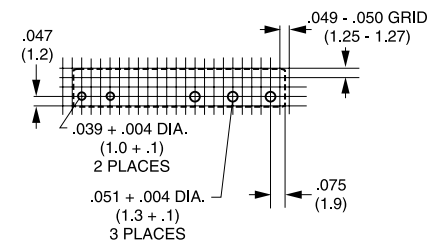



## DIN Rail Interface Module and Accessories for V23092 Series (SNR) Relay PC Board Relay

Users should thoroughly review the technical data before selecting a product part number. It is recommended that user also seek out the pertinent approvals files of the agencies/laboratories and review them to ensure the product meets the requirements for a given application.

### Features

- Module width is 0.2 in (5.08mm).
- Narrow width permits high density packing of modules on a DIN rail.
- Jumper bars available.
- Available as a set or as individual components.

### Technical Information

**Rated Current / Rated Voltage:** 6A / 250VAC.  
**Dielectric Strength, Coil-to-Contact:** >4,000Vrms.  
**Insulation Category (VDR 0110b):** C / 250.  
**Operating Ambient Temperature:** - 20°C to +55°C.  
**Protection Category:** IP 20.  
**Protection Against Accidental Contact Meeting:** VBG 4.  
**Wire Cross Section with/without Bootlace Crimp:** 0.22 - 2.5mm<sup>2</sup>.  
**Terminal Torque (Nominal / Maximum):** .295 / .442 ft-lb (0.4 / 0.6 Nm).

### Outline Dimensions

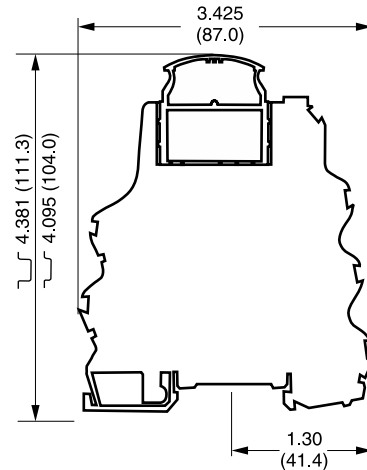

### Component Parts

ST 1F 000	Socket without LED
ST 1F L24	Socket with LED for 12-24VDC.
ST 16 016	Mounting frame for relay, without marking
ST 17 002	Jumper bar, 2 pole
ST 17 005	Jumper bar, 5 pole
ST 17 010	Jumper bar, 10 pole
ST 16 040	Marking plate, consisting of 100 marking tags



### Sets - Relay in frame, mounted in socket

ST 1P3 024	24VDC, AgSnO <sub>2</sub> contacts
ST 1P3 L12	12VDC, with LED, AgSnO <sub>2</sub> contacts
ST 1P3 L24	24VDC, with LED, AgSnO <sub>2</sub> contacts
ST 1P3 L48	48VDC, with LED, AgSnO <sub>2</sub> contacts
ST 1P2 L24	24VDC, with LED, Au plated AgSnO <sub>2</sub> contacts



# Ry II series

## 8 Amp Miniature Printed Circuit Board Relay

UL File E214025  
NR 10071

Users should thoroughly review the technical data before selecting a product part number. It is recommended that users also seek out the pertinent approvals files of the agencies/laboratories and review them to ensure the product meets the requirements for a given application.

### Features

- 1 Form A (SPST-NO) and 1 Form C (SPDT).
- 8 amp rated current.
- Sensitive coil 220 mW.
- 12.3 mm height.
- 8 mm coil to contact spacing.
- Flux-tight and washable (sealed) versions.

### Mechanical Data

**Termination:** Printed circuit terminals. Sockets available.  
**Enclosure (94 V-0 rated):** Flux-tight (RT II) or sealed (RTIII) plastic case.  
**Weight:** 0.28 oz. (8 g) approximately.

### Contact Data @ 70°C

**Arrangements:** 1 Form A (SPST-NO) and 1 Form C (SPDT), single contact.  
**Material:** Silver-cadmium oxide; Silver-tin oxide; and Silver-nickel 0.15 with or without gold plating.

**Expected Mechanical Life:** 30 million operations minimum.

#### Ratings:

- Current:** 8A
- Voltage:** 250VAC.
- Power (breaking):** 2,000 VA.
- Voltage (breaking):** 440VAC.
- Current (making, max. 4s at 10% duty cycle):** 30A.
- UL508 @ 70°C (RY610 type)**
  - 8 amp 28VDC 30,000 ops.
  - 280mA 250VDC 30,000 ops.
  - 1/2 HP 240VAC.
  - 1/4 HP 277VAC.
  - B300 120 or 240VAC
- VDE 0631 @ 85°C (RY531 type)**
  - 6 (4) amp, 250VAC 100,000 ops.

### Contact Life

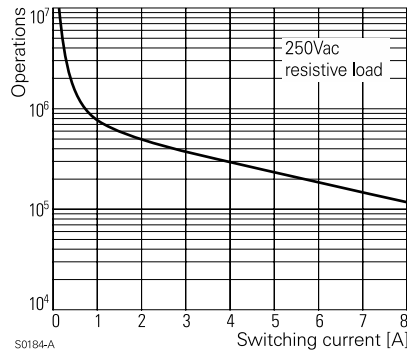

S0184-A

### Initial Dielectric Strength

**Between Open Contacts:** 1,000Vrms.  
**Between Coil and Contacts:** 5,000Vrms.  
**Creepage/Clearance:** 8/8mm.

### Max. DC Load Breaking Capacity

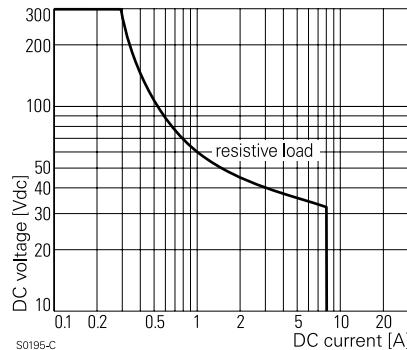

S0195-C

### Coil Data DC @ 20°C

**Nominal Coil Power:** 220mW.

Nominal Voltage VDC	DC Resistance in Ohms ±10%	Must Operate Voltage VDC	Drop-out Voltage VDC	Maximum Voltage VDC	Nominal Coil Current (mA)
5	113	3.5	0.5	11.8	44.0
6	164	4.2	0.6	14.1	36.7
12	620	8.4	1.2	28.2	19.3
24	2,350	16.8	2.4	56.4	10.2
48	9,600	33.6	4.8	112.8	5.0

### Coil Operating Range

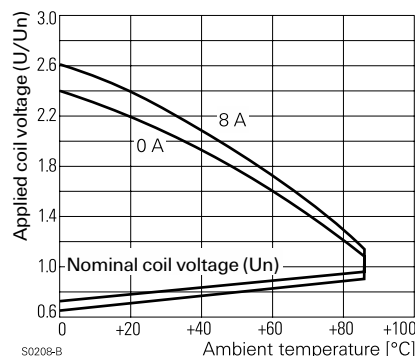

S0208-B

### Operate Data

**Must Operate Voltage:** See Coil Data table.  
**Operate Time :** 7 ms, at nom. voltage.  
**Release Time:** 3 ms, at nom. voltage.  
**Bounce Time (N/O contact) :** 1 ms, at nom. voltage.  
**Switching Rate:** 3,600 ops./hr. max. at rated load.

### Environmental Data

**Temperature Range:**  
**Operating:** -40°C to +85°C.  
**Vibration:** (10 to 500 Hz.) 5g.  
**Shock (destructive):** >100g.

**Ordering Information**

Typical Part Number ▶

**RY**

**6**

**1**

**0**

**012**

**1. Basic Series:**

RY = RY II miniature printed circuit board relay.

**2. Version:**

- 2 = Flux-tight, pins on 3.2 mm spacing. Only available with contact arrangement 1.
- 5 = Flux-tight, pins on 5 mm spacing. Only available with contact arrangement 3.
- 6 = Sealed, pins on 3.2 mm spacing. Only available with contact arrangement 1.
- A = Sealed, pins on 5 mm spacing. Only available with contact arrangement 3.

**3. Contact Arrangement:**

- 1 = 1 Form C (SPDT) Only available with 3.2 mm pin spacing.
- 3 = 1 Form A (SPST-NO) Only available with 5 mm pin spacing.

**4. Contact Material:**

- 0 = Silver-cadmium oxide.
- 1 = Silver-nickel 0.15
- 2 = Silver-nickel 0.15 with gold plating
- 3 = Silver-tin oxide.

**5. Coil Voltage:**

- 005 = 5VDC
- 006 = 6VDC
- 012 = 12VDC
- 024 = 24VDC
- 048 = 48VDC

**Our authorized distributors are more likely to maintain the following items in stock for immediate delivery.**

None at present.

**Outline Dimensions**

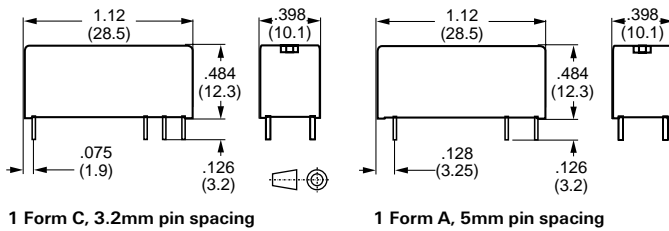

**PC Board Layouts & Wiring Diagrams (Bottom Views)**

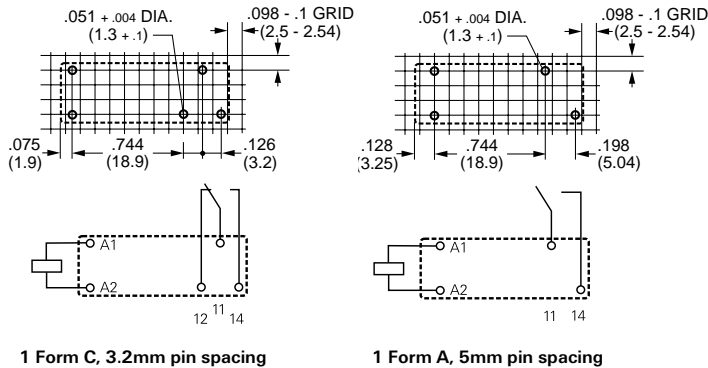

*Sensitive, Low Profile, Hi-Current  
Relay Designed to Meet  
International Standards*

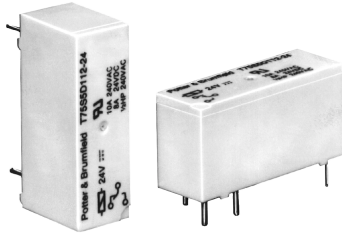

# T75 series

## 14 Amp, PC Board Miniature Relay

File E29244

File LR45064

File No. 3919

Users should thoroughly review the technical data before selecting a product part number. It is recommended that user also seek out the pertinent approvals files of the agencies/laboratories and review them to ensure the product meets the requirements for a given application.

### Features

- High sensitivity – nominal coil power requirement is as low as 212mW.
- Low profile, .591 in. (15mm) tall case uses only .465 in<sup>2</sup> (3cm<sup>2</sup>) of area on the printed circuit board, permitting high density circuit design.
- Power switching capability – contacts rated 14 amps in 1 Form A (SPST-NO) or 1 Form C (SPDT) arrangements.
- Designed to meet UL, CSA, VDE, SEMKO and SEV requirements.
- Designed to meet VDE 8mm spacing, 4kV dielectric, coil to contacts.
- Designed to meet 3 mm creepage between contacts.
- Conforms to: VDE 0110 – Insulation Group C (250V)  
VDE 435 Part 201 – High current applications  
VDE 0804 – Telecommunications equipment  
VDE 0631 – Temperature controllers and limiters  
VDE 0700 – Household appliances  
VDE 0805/5.90 – Office machines
- Immersion cleanable<sup>§</sup>, ultrasonically sealed case.
- Well suited for a broad range of applications e.g. HVAC, appliances, security and industrial control.

§ For more details, refer to application note 13C265, "Mounting, Termination and Cleaning of PC Board Relays."

### Contact Ratings @ 25°C with relay properly vented. Remove vent nib after soldering and cleaning.

**Arrangements:** 1 Form A (SPST-NO) and 1 Form C (SPDT).

**Material:** Silver-cadmium oxide.

**Expected Mechanical Life:** 20 million operations.

#### Expected Electrical Life:

- 100,000 operations at 8 amps, 240VAC.
- 50,000 operations at 14 amps NO / 5 amps NC, 120VAC Res.
- 30,000 operations at 7.2 FLA, 45 LRA, 120VAC.
- 10,000 operations at 5 FLA, 30 LRA, 240VAC.
- 30,000 operations at B300 pilot duty (360VA, 240VAC; 470VA, 120VAC).

#### Contact Ratings (See Figure 1):

**Maximum Switched Voltage:** 380VAC.  
**Maximum Switched Current:** 14/5 (N.O./N.C.) amps, AC resistive; 8 amps DC (see Fig. 1)

**Maximum Switched Power:** 200W, DC; 2,000VA, AC.

**Minimum Required Contact Load:** 12V, 100mA.

**VDE Contact Ratings:** 8 amps, 250VAC.

**UL/CSA Contact Ratings:** 10 amps, 240VAC; 8 amps 24VDC; 1/3 HP, 120VAC; 1/2 HP, 240VAC.

**Figure 1 - DC Switching Load Limit Curve**

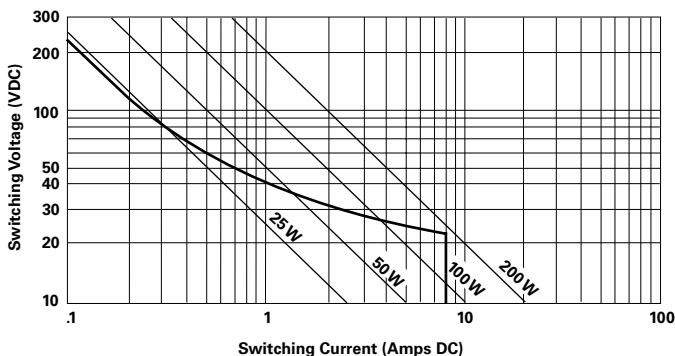

### Initial Dielectric Strength

**Between Open Contacts:** 1,000V rms.

**Between Contacts and Coil:** 4,000V rms, 8mm.

### Coil Data

**Voltage:** 3 to 60VDC.

**Maximum Power @ 25°C:** 1W.

**Nominal Power @ 25°C:** 230mW, typ.

**Temperature Rise:** 85°C per Watt.

**Duty Cycle:** Continuous.

### Coil Data

	Nominal Voltage	DC Resistance in Ohms ±10%	Must Operate Voltage	Nominal Coil Current (mA)
DC Coils	3	40	2.1	75.0
	5	118	3.6	42.4
	6	165	4.3	36.4
	9	365	6.4	24.7
	12	650	8.5	18.5
	18	1,455	12.8	12.4
	24	2,270	17.2	10.6
	36	5,460	25.4	6.4
	48	8,790	34.5	5.5
	60	15,265	42.8	3.9

### Operate Data @ 25°C

**Must Operate Voltage:** 72% of nom. voltage or less.

**Must Release Voltage:** 10% of nom. voltage or more.

**Operate Time (Excluding Bounce):** 6 ms, typ., at nom. voltage.

**Release Time (Excluding Bounce):** 2.5 ms, typ., at nom. voltage.

**Maximum Switching Rate:** 20 operations/second.

**Maximum Continuous Operating Voltage:** 225% of nom. voltage.

### Temperature Range

**Storage:** -40°C to +130°C.

**Operating:** -40°C to +70°C.

### Mechanical Data

**Termination:** Printed circuit terminals.

**Enclosures:** Immersion cleanable, plastic sealed case.

**Weight:** 0.65 oz. (18.5g) approximately.

Ordering Information

Typical Part Number ▶ T75

S

5

D

1

1

2

-12

1. Basic Series:

T75 = Low profile, printed circuit board relay.

2. Enclosure:

S = Immersion cleanable, plastic sealed case.

3. Contact Arrangement:

1 = 1 Form A (SPST-NO)  
5 = 1 Form C (SPDT)

4. Coil Input:

D = DC voltage

5. Coil Configuration:

1 = Single coil, non-latching (monostable)

6. Mounting and Terminals:

1 = Printed circuit terminals

7. Contact Material:

2 = Silver-cadmium oxide (AgCdO)

8. Coil Voltage:

03 = 3VDC	06 = 6VDC	12 = 12VDC	24 = 24VDC	48 = 48VDC
05 = 5VDC	09 = 9VDC	18 = 18VDC	36 = 36VDC	60 = 60VDC

Our authorized distributors are more likely to maintain the following items in stock for immediate delivery.

T75S5D112-05  
T75S5D112-12  
T75S5D112-24

Outline Dimensions

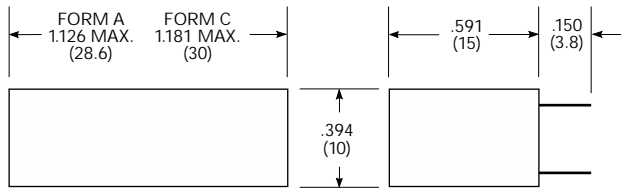

CONTACT TERMINALS: .023 x .040 (.58 x 1.02) REF.  
COIL TERMINALS: .024 (.61) DIA. REF.

Wiring Diagram (Bottom View)

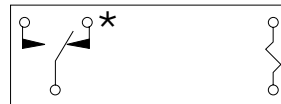

\* ON SINGLE THROW MODELS, ONLY NECESSARY TERMINALS ARE PRESENT.

PC Board Layouts (Bottom Views)

1 Form C

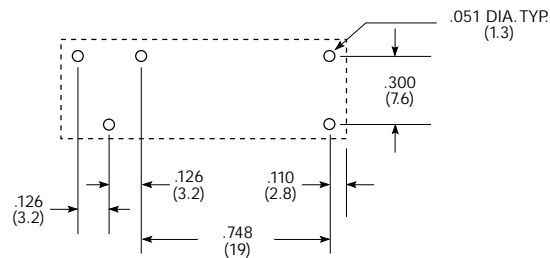

1 Form A

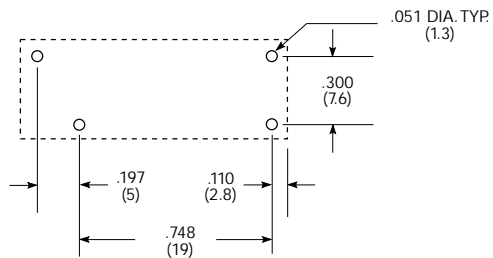

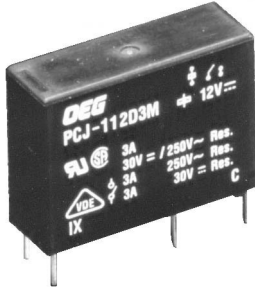

# PCJ series

## Slim 5 Amp Miniature Power PC Board Relay

**Air Conditioners, Refrigerators, Microwave Ovens**

UL File No. E82292

CSA File No. 1031444

VDE File No. 122301

Users should thoroughly review the technical data before selecting a product part number. It is recommended that user also seek out the pertinent approvals files of the agencies/laboratories and review them to ensure the product meets the requirements for a given application.

### Features

- Slim outline, L20.4 x W7 x H15 (mm).
- 1 Form A (SPST-NO) contact arrangement.
- High dielectric capacity of 4kV.
- UL, CSA, VDE approvals.
- Immersion cleanable, sealed version available.
- Cadmium-free contacts.

### Contact Data @ 20°C

**Arrangements:** 1 Form A (SPST-NO).

**Material:** Ag Alloy.

**Max. Switching Rate:** 300 ops./ min. (no load).  
20 ops./ min. (rated load).

**Expected Mechanical Life:** 5 million ops (no load).

**Expected Electrical Life:** 100,000 ops (rated load).

**Minimum Load:** 100mA @ 5VDC.

**Initial Contact Resistance:** 100Mohms @ 1A, 6VDC.

### Coil Data @ 20°C

PCJ				
Rated Coil Voltage (VDC)	Nominal Current (mA)	Coil Resistance (ohms) ± 10%	Must Operate Voltage (VDC)	Must Release Voltage (VDC)
5	40.0	125	3.75	0.25
6	33.3	180	4.50	0.30
9	22.5	405	6.75	0.45
12	16.7	720	9.00	0.60
18	11.1	1,620	13.50	0.90
24	8.6	2,880	18.00	1.20

### Contact Ratings

**Ratings:** 5A @ 250VAC resistive.

**Max. Switched Voltage:** AC: 275V.  
DC: 30V.

**Max. Switched Current:** 5A.

**Max. Switched Power:** 1,250VA, 150W.

### Initial Dielectric Strength

**Between Open Contacts:** 750VAC, 50/60 Hz. (1 min.).

**Between Contacts and Coil:** 4,000VAC, 50/60 Hz. (1 min.).

**Surge Voltage Between Coil and Contacts:** 7,000V (1.2/50µs).

### Initial Insulation Resistance

**Between Mutually Insulated Conductors:** 1,000Mohm @ 500VDCM.

### Coil Data

**Voltage:** 5 to 24VDC.

**Duty Cycle:** Continuous.

**Nominal Power:** 200mW.

**Max. Coil Power:** 130% of nominal.

### Operate Data @ 20°C

**Must Operate Voltage:** 75% of nominal voltage or less.

**Must Release Voltage:** 5% of nominal voltage or more.

**Operate Time:** 10ms max.

**Release Time:** 4ms max.

### Environmental Data

**Temperature Range:**

**Operating:** -30°C to + 70°C.

**Vibration, Mechanical:** 10 to 55Hz., 1.5mm double amplitude.

**Operational:** 10 to 55Hz., 1.5mm double amplitude.

**Shock, Mechanical:** 1,000m/s<sup>2</sup> (100G approximately).

**Operational:** 100m/s<sup>2</sup> (10G approximately).

**Operating Humidity:** 20 to 85% RH. (Non-condensing).

### Mechanical Data

**Termination:** Printed circuit terminals.

**Weight:** 0.14 oz. (4g) approximately.

**Ordering Information**

Typical Part Number ▶

**PCJ -1 05 D 3 M H ,000**

**1. Basic Series:**

PCJ = Miniature 1 Form A relay

**2. Termination:**

1 = 1 pole

**3. Coil Voltage:**

05 = 5VDC	09 = 9VDC	18 = 18VDC
06 = 6VDC	12 = 12VDC	24 = 24VDC

**4. Coil Input:**

D = Standard 200mW

**5. Contact Material:**

3 = AgNi

**6. Contact Arrangement:**

M = 1 Form A (NO)

**7. Enclosure:**

Blank = Vented (Flux-tight) cover      H = Sealed plastic case

**8. Suffix:**

,000 = Standard model      Other Suffix = Custom model

**Our authorized distributors are more likely to maintain the following items in stock for immediate delivery.**

PCJ-105D3MH,000  
PCJ-112D3MH,000  
PCJ-124D3MH,000

**Outline Dimensions**

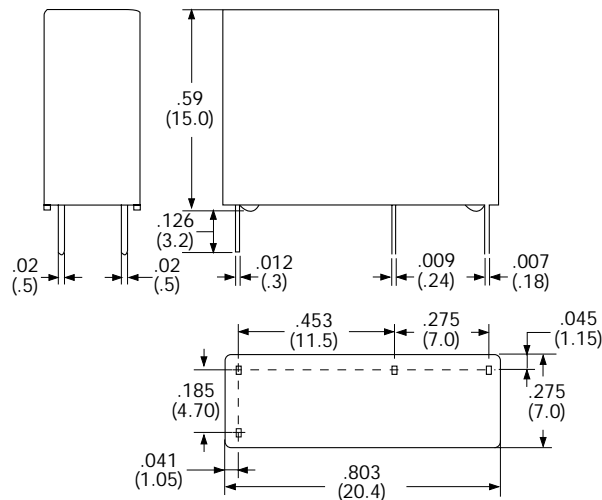

**Wiring Diagram (Bottom View)**



**PC Board Layout (Bottom View)**

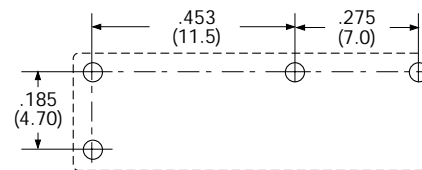

**Reference Data**

**Coil Temperature Rise**

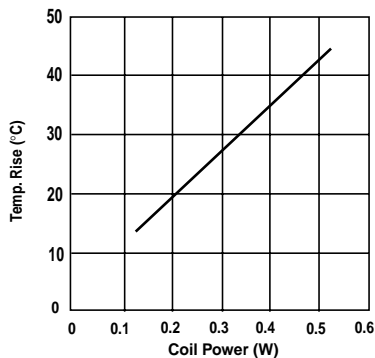

**Operate Time**

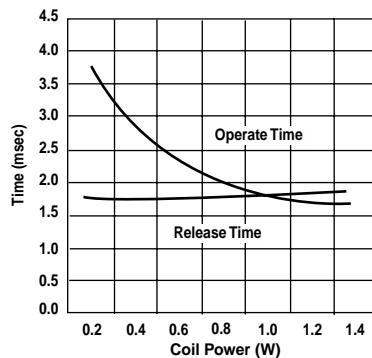

**Life Expectancy**

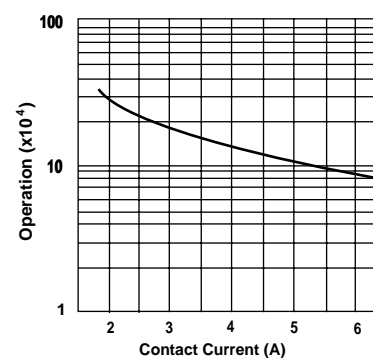

Dimensions are shown for reference purposes only.

Dimensions are in inches over (millimeters) unless otherwise specified.

Specifications and availability subject to change.

www.tycoelectronics.com  
Technical support:  
Refer to inside back cover.



# PCH series

## 5 - 10 Amp Miniature 1 Form A or C Power PC Board Relay

Air Conditioners, Refrigerators, Microwave Ovens

UL File No. E82292

CSA File No. LR48471

VDE File No. 119568

Users should thoroughly review the technical data before selecting a product part number. It is recommended that user also seek out the pertinent approvals files of the agencies/laboratories and review them to ensure the product meets the requirements for a given application.

### Features

- 1 Form A (SPST-NO) or 1 Form C (SPDT) contact arrangements.
- 5 or 10A ratings.
- Compact size 20L x 10W x 15.2H (mm).
- High surge voltage of 8000V.
- Cadmium-free contacts.
- Sensitive (200mW) coil available on 1 Form A types.
- UL, CSA, VDE approval.

### Contact Data @ 20°C

**Arrangements:** 1 Form A (SPST-NO) and 1 Form C (SPDT).

**Material:** AgSnO.

**Max. Switching Rate:** 300ops./min. (no load).  
20ops./min. (rated load).

**Expected Mechanical Life:** 5 million ops (no load).

**Expected Electrical Life:** 100,000ops (rated load).

**Minimum Load:** 100mA @ 5VDC.

**Initial Contact Resistance:** 100 milliohms @ 1A, 6VDC.

### Contact Ratings

**Ratings: Models with 1 Form C Contacts, 400mW Coil**

- 5A (NO) / 3A (NC) @ 30VDC resistive.
- 5A (NO) / 3A (NC) @ 277VAC resistive.
- 10A (NO) @ 125VAC resistive.
- TV-3 (NO).

**Models with 1 Form A Contacts, 400mW Coil**

- 5A @ 277VAC/30VDC resistive.
- 10A @ 125VAC resistive.
- TV-3.

**Models with 1 Form A Contacts, 200mW Coil**

- 5A @ 277VAC/30VDC resistive.
- 10A @ 125VAC resistive.

**Max. Switched Voltage:** AC: 277V.  
DC: 30V.

**Max. Switched Current:** 10A (NO) / 3A(NC).

**Max. Switched Power:** 1400VA, 150W (NO); 850VA, 90W (NC).

### Initial Dielectric Strength

**Between Open Contacts:** 750VAC, 50/60 Hz. (1 min.).

**Between Contacts and Coil:** 4,000VAC, 50/60 Hz. (1 min.).

**Surge Voltage Between Coil and Contacts:** 8,000V (1.2/50µs).

### Initial Insulation Resistance

**Between Mutually Insulated Conductors:** 1000Mohm @ 500VDCM.

### Coil Data

**Voltage:** 5 to 48VDC.

**Duty Cycle:** Continuous.

**Nominal Power:** 200mW or 400mW.

**Max. Coil Power:** 130% of nominal.

### Coil Data @ 20°C

200mW Coils (Only available with 1 Form A contact arrangements)				
Rated Coil Voltage (VDC)	Nominal Current (mA)	Coil Resistance (ohms) ± 10%	Must Operate Voltage (VDC)	Must Release Voltage (VDC)
5	40.0	125	3.75	0.25
6	30.0	180	4.50	0.30
9	22.5	400	6.75	0.45
12	16.7	720	9.00	0.60
24	8.6	2,800	18.00	1.20

400mW Coils				
Rated Coil Voltage (VDC)	Nominal Current (mA)	Coil Resistance (ohms) ± 10%	Must Operate Voltage (VDC)	Must Release Voltage (VDC)
5	80.0	62.5	3.75	0.25
6	66.7	90.0	4.50	0.30
9	44.4	202.5	6.75	0.45
12	33.3	360.0	9.00	0.60
18	22.2	810.0	13.50	0.90
24	11.1	1,440.0	18.00	1.20
48	5.6	5,760.0	36.00	2.40

### Operate Data @ 20°C

**Must Operate Voltage:** 75% of nominal voltage or less.

**Must Release Voltage:** 5% of nominal voltage or more.

**Operate Time:** 10ms max.

**Release Time:** 5ms max.

### Environmental Data

**Temperature Range:**

**Operating:** Models with Class F insulation: -30°C to +85°C.

**Vibration, Mechanical:** 10 to 55Hz., 1.5mm double amplitude.

**Operational:** 10 to 55Hz., 1.5mm double amplitude.

**Shock, Mechanical:** 1,000m/s<sup>2</sup> (100G approximately).

**Operational:** 100m/s<sup>2</sup> (10G approximately).

**Operating Humidity:** 20 to 85% RH. (Non-condensing).

### Mechanical Data

**Termination:** Printed circuit terminals.

**Weight:** 0.25 oz (7g) approximately.

**Ordering Information**

Typical Part Number ▶

**PCH**

**-1**

**12**

**D**

**2**

**H**

**,001**

**1. Basic Series:**

PCH = Miniature 1 Form C relay

**2. Termination:**

1 = 1 pole

**3. Coil Voltage:**

05 = 5VDC      09 = 9VDC      24 = 24VDC  
06 = 6VDC      12 = 12VDC      48 = 48VDC

**4. Coil Input:**

D = Standard 400mW      L = Sensitive 200mW (Only available with 1 Form A contacts)

**5. Contact Material:**

2 = AgSnO

**6. Contact Arrangement:**

Blank = 1 Form C (Only available with Standard 400mW coil)      M = 1 Form A

**7. Enclosure:**

Blank = Vented (Flux-tight) cover      H = Sealed plastic case

**8. Insulation class:**

Blank = Class 155(F) system

**9. Option:**

,001 = Standard model      Other Suffix = Special options

**Our authorized distributors are more likely to maintain the following items in stock for immediate delivery.**

PCH-105D2H,001    PCH-124D2H,001  
PCH-112D2H,001

**Outline Dimensions**

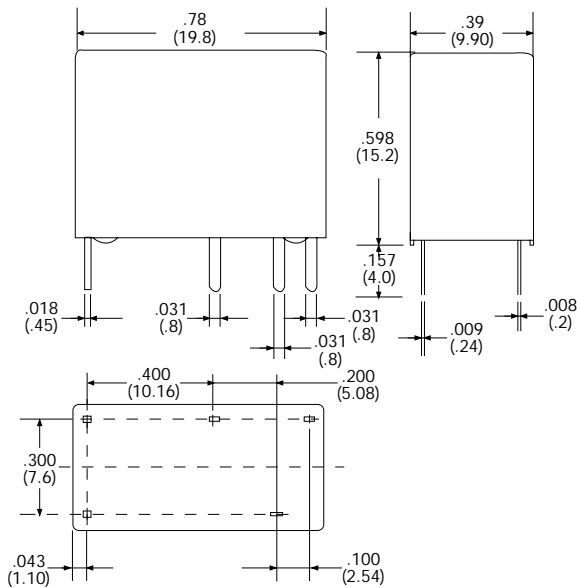

**Wiring Diagram (Bottom View)**

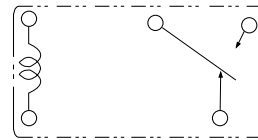

**NOTE:** Only necessary terminals are present on 1 Form A models.

**PC Board Layout (Bottom View)**

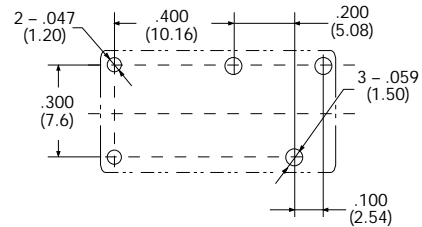

**NOTE:** Only necessary terminals are present on 1 Form A models.

**Reference Data (Typical Values)**

(Only applicable for 1 Form C, 400mW coil model with 277VAC load on NO)

**Coil Temperature Rise**

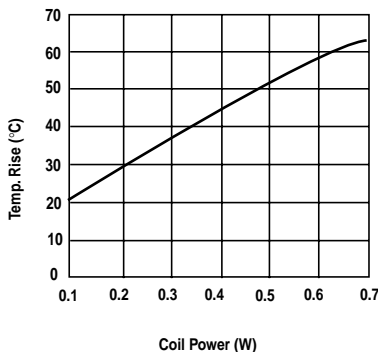

**Operate Time**

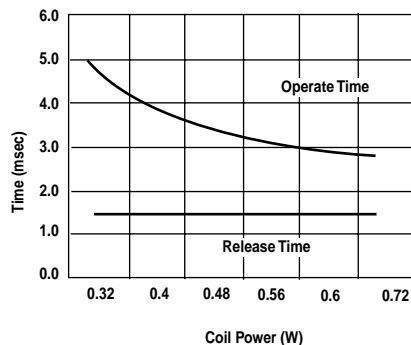

**Life Expectancy**

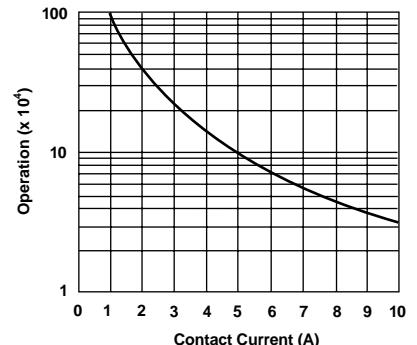

# T77 series

## 10 Amp Miniature PC Board Relay

File E29244

File LR48471

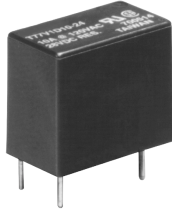

Users should thoroughly review the technical data before selecting a product part number. It is recommended that user also seek out the pertinent approvals files of the agencies/laboratories and review them to ensure the product meets the requirements for a given application.

### Features

- Small size for high density PC board mounting.
- 1 Form A contact arrangements.
- Creepage spacings of 6.5mm between contact and coil.
- Ideal for appliance, office equipment.
- 4,000VAC dielectric strength between contact and coil.
- UL Class F (155°C) approved insulation system.

### Contact Data @ 20°C

**Arrangements:** 1 Form A (SPST-NO).

**Material:** Contact rating 3 - Silver.  
Contact rating 10 - Silver alloy.

**Max. Switching Rate:** 300 ops./min. (no load).  
30 ops./min. (rated load).

**Expected Mechanical Life:** 10 million operations.

**Expected Electrical Life:** 100,000 operations.

**Minimum Contact Load:** 10mA @ 5VDC.

**Initial Contact Resistance:** 100 milliohms max. @ 100mA, 6VDC.

### Coil Data @ 20°C

**Voltage:** 3 to 24VDC.

**Nominal Coil Power:** Contact rating 3 = 200mW.  
Contact rating 10 = 450mW.

**Coil Temperature Rise:** Contact rating 3 = 35°C max.  
Contact rating 10 = 40°C max.

**Max. Coil Power:** 120% of nominal.

**Duty Cycle:** Continuous.

### Coil Data @ 20°C

Rated Coil Voltage (VDC)	Coil Resistance (Ohms) ±10%		Must Operate Voltage (VDC)	Must Release Voltage (VDC)
	Contact Rating 3	Contact Rating 10		
3	45	20	2.25	0.15
5	125	55	3.75	0.25
12	720	320	9.00	0.60
24	2,800	1,280	18.00	1.20

### Contact Ratings @ 20°C with relay properly vented. Remove vent nib after soldering and cleaning.

Contact Rating	UL/CSA Ratings	Type	Operations
3	3A @ 277VAC	Resistive	6,000
	10LRA/1.5FLA @ 120VAC	Motor	30,000**
	5.4LRA/0.9FLA @ 240VAC	Motor	30,000**
	3LRA/1.5FLA @ 120VAC	Motor	100,000*
	3A @ 250VAC	Resistive	100,000
	3A @ 250VAC UL	General Purpose	100,000
	3A @ 30VDC	Resistive	100,000
	2A @ 120VAC	Gen. Purpose	100,000***
	3A @ 120VAC	Resistive	100,000***
10	10LRA/1.5FLA @ 120VAC	Motor	30,000**
	5.4LRA/0.9FLA @ 240VAC	Motor	30,000**
	10A @ 250VAC	Resistive	100,000
	10A @ 30VDC	Resistive	100,000
	10A @ 250VAC UL	General Purpose	200,000

\*Denotes test at 70°C ambient temperature.

\*\*Denotes test at 85°C ambient temperature.

\*\*\*Denotes test at 105°C ambient temperature.

### Operate Data @ 20°C

**Operate Time:** 10 ms, max. (excluding bounce).

**Release Time:** 4 ms, max. (excluding bounce).

### Environmental Data

**Temperature Range:** Storage: -40°C to +130°C.

**Operating:** -30°C to +55°C.

**Contact Rating 3:** -40°C to +80°C.

**Contact Rating 10:** -40°C to +55°C.

**Vibration: Mechanical:** 10 to 55 Hz., 1.5mm double amplitude.

**Operational:** 10 to 55 Hz., 1.5mm double amplitude.

**Shock: Mechanical:** 100g min.

**Operational:** 10g min.

**Operating Humidity:** 45 to 85% RH.

### Initial Dielectric Strength

**Between Open Contacts:** 750VAC 50/60 Hz. (1 minute).

**Between Coil and Contacts:** 4,000VAC 50/60 Hz. (1 minute).

### Initial Insulation Resistance

**Between Mutually Insulated Elements:** 10<sup>8</sup> ohms, min. @ 500VDC.

### Mechanical Data

**Termination:** Printed circuit board.

**Enclosures (94V-0 Flammability Ratings):**

**T77S:** Immersion cleanable.

**T77V:** Vented, flux-tight, plastic cover.

**Weight:** 0.36 oz. (9g).

**Figure 1 - Coil Temperature Rise**

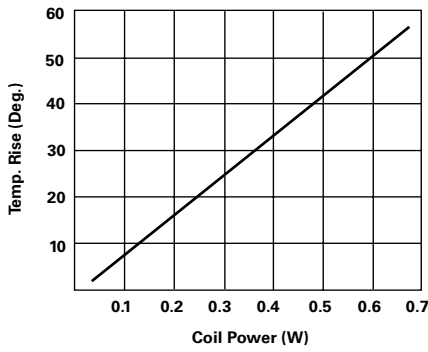

**Operate Time**

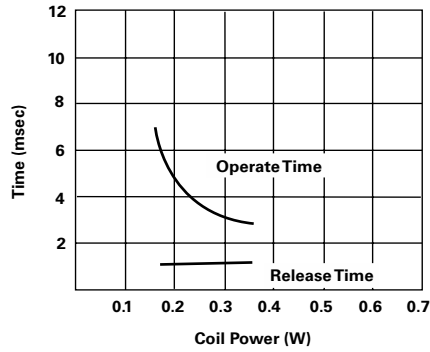

**Life Expectancy**

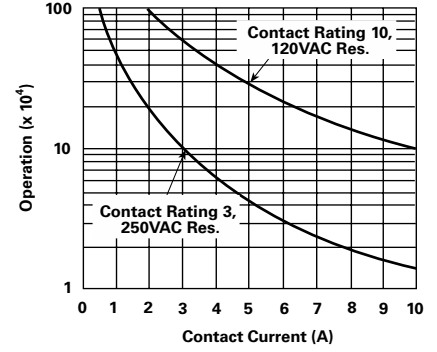

**Note:** Graphical data should not be used as a substitute for specific application verification. To be used for estimates only.

**Ordering Information**

Typical Part Number ▶ **T77 V 1 D 10 -24**

- 1. Basic Series:**  
T77 = Miniature PCB relay.
- 2. Enclosure:**  
V = Vented (Flux-tight)\*  
S = Immersion cleanable case
- 3. Contact Arrangement:**  
1 = (SPST-NO)
- 4. Coil Input:**  
D = DC Voltage
- 5. Contact Rating:**  
3 = 3A    10 = 10A
- 6. Coil Voltage:**  
03 = 3VDC    05 = 5VDC    12 = 12VDC    24 = 24VDC

\*Not suitable for immersion cleaning processes.

**Our authorized distributors are more likely to maintain the following items in stock for immediate delivery.**

- |            |             |            |             |
|------------|-------------|------------|-------------|
| T77V1D3-12 | T77V1D10-12 | T77S1D3-12 | T77S1D10-12 |
| T77V1D3-24 | T77V1D10-24 | T77S1D3-24 | T77S1D10-24 |

**Outline Dimensions**

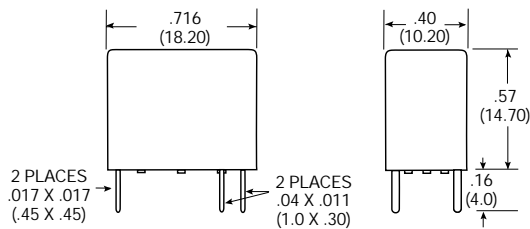

**Wiring Diagram (Bottom View)**

**1 Form A**

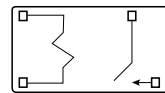

**Suggested PC Board Layout (Bottom View)**

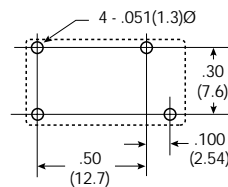

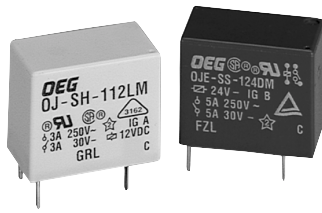

# OJ/OJE series

## 3-10 Amp Miniature, PC Board Relay

Appliances, HVAC, Industrial Control.

UL File No. E82292

CSA File No. LR48471

VDE File No. 10080

TUV File No. R75081

Users should thoroughly review the technical data before selecting a product part number. It is recommended that user also seek out the pertinent approvals files of the agencies/laboratories and review them to ensure the product meets the requirements for a given application.

### Features

- Miniature size 18.2 x 10.2 x 14.7h.
- 1 Form A (SPST-NO) contact arrangement.
- Designed to meet UL, CSA, VDE, TUV requirements.
- Designed to meet 4kV dielectric between coil and contacts (OJ).
- Sensitive and standard coils available.
- Immersion cleanable, sealed version available.

### Contact Data @ 20°C

**Arrangements:** 1 Form A (SPST-NO).

**Material:** Ag, Ag Alloy.

**Max. Switching Rate:** 300 ops./min. (no load).  
30 ops./min. (rated load).

**Expected Mechanical Life:** 10 million operations (no load).

**Expected Electrical Life:** 100,000 operations (rated load).

**Minimum Load:** 100mA @5VDC.

**Initial Contact Resistance:** 100 milliohms @ 1A,6VDC.

### Contact Ratings

**Ratings: OJ/OJE-LM:** 3A @ 250VAC resistive,  
3A @ 28VDC resistive.

**OJ/OJE-LMH:** 8A @ 250VAC resistive,  
8A @ 28VDC resistive.

**OJ/OJE-DM:** 5A @ 250VAC resistive,  
5A @ 28VDC resistive.

**OJ/OJE-HM:** 10A @ 250VAC resistive,  
10A @ 28VDC resistive.

**Max. Switched Voltage: AC:** 265V.  
**DC:** 30V.

**Max. Switched Power:**  
**OJ/OJE-LM:** 720VA, 90W  
**OJ/OJE-LMH:** 1,800VA, 200W  
**OJ/OJE-DM:** 1,200VA, 150W  
**OJ/OJE-HM:** 2,500VA, 280W

**Note:** Consult factory regarding TV-5 rated models.

### Initial Dielectric Strength

**Between Open Contacts:**

**OJ:** 750VAC 50/60 Hz. (1 minute).

**OJE:** 750VAC 50/60 Hz. (1 minute).

**Between Coil and Contacts:**

**OJ:** 4,000VAC 50/60 Hz. (1 minute).

**OJE:** 3,000VAC 50/60 Hz. (1 minute).

**Surge Voltage Between Coil and Contacts:**

**OJ:** 10,000V (1.2/50µs).

**OJE:** 5,000V (1.2/50µs).

### Initial Insulation Resistance

**Between Mutually Insulated Elements:** 1,000M ohms min. @ 500VDCM.

### Coil Data

**Voltage:** 5 to 48VDC.

**Nominal Power: OJ/OJE-LM and LMH:** 200 mW.  
**OJ/OJE-DM and HM:** 450 mW.

**Coil Temperature Rise:**

**OJ/OJE-LM and LMH:** 30°C max., at rated coil voltage.

**OJ/OJE-DM and HM:** 40°C max., at rated coil voltage.

**Max. Coil Power:** 130% of nominal.

**Duty Cycle:** Continuous.

### Coil Data @ 20°C

OJ/OJE-L Sensitive				
Rated Coil Voltage (VDC)	Nominal Current (mA)	Coil Resistance (ohms) ± 10%	Must Operate Voltage (VDC)	Must Release Voltage (VDC)
5	40.0	125	3.75	0.25
6	33.3	180	4.50	0.30
9	22.5	400	6.75	0.45
12	16.7	720	9.00	0.60
24	8.6	2,800	18.00	1.20
OJ/OJE-D and -H Standard				
Rated Coil Voltage (VDC)	Nominal Current (mA)	Coil Resistance (ohms) ± 10%	Must Operate Voltage (VDC)	Must Release Voltage (VDC)
5	91.0	55	3.50	0.25
6	75.0	80	4.20	0.30
9	50.0	180	6.30	0.45
12	37.5	320	8.40	0.60
24	18.8	1,280	16.80	1.20
48	9.4	5,100	33.60	2.40

### Operate Data

**Must Operate Voltage:**

**OJ/OJE -L:** 75% of nominal voltage or less.

**OJ/OJE -D and -H:** 70% of nominal voltage or less.

**Must Release Voltage:**

**OJ/OJE -L:** 5% of nominal voltage or more.

**OJ/OJE -D and -H:** 5% of nominal voltage or more.

**Operate Time: OJ/OJE -L:** 15 ms max.

**OJ/OJE -D and -H:** 10 ms max.

**Release Time:** 4 ms max.

### Environmental Data

**Temperature Range:**

**Operating: OJ/OJE-L:** -30°C to +80°C

**OJ/OJE-D and -H:** -30°C to +60°C.

**Vibration, Mechanical:** 10 to 55 Hz., 1.5mm double amplitude

**Operational:** 10 to 55 Hz., 1.5mm double amplitude.

**Shock, Mechanical:** 1,000m/s<sup>2</sup> (100G approximately).

**Operational:** 100m/s<sup>2</sup> (10G approximately).

**Operating Humidity:** 20 to 85% RH. (Non-condensing).

### Mechanical Data

**Termination:** Printed circuit terminals.

**Enclosure (94V-0 Flammability Ratings):**

**OJ/OJE-SS:** Vented (Flux-tight), plastic cover.

**OJ/OJE-SH:** Sealed, plastic case.

**Weight:** 0.32 oz (9g) approximately.

**Ordering Information**

Typical Part Number ►

**OJE -SH -1 12 L M H ,095**

**1. Basic Series:**

OJ = 4kV dielectric, coil and contacts.  
OJE = 3kV dielectric, coil and contacts.

**2. Enclosure:**

SS = Vented (Flux-tight)\*, plastic cover.  
SH = Sealed, plastic case.

**3. Termination:**

1 = 1 pole

**4. Coil Voltage:**

05 = 5VDC      09 = 9VDC      24 = 24VDC  
06 = 6VDC      12 = 12VDC      48 = 48VDC

**5. Coil Input/Contact Rating:**

L = Sensitive (200mW) Coil, 3A Contacts\*\*      D = Standard (450mW) Coil, 5A Contacts  
H = Standard (450mW) Coil, 10A Contacts

**6. Contact Arrangement:**

M = 1 Form A, SPST-NO

**7. High Capacity Contact Rating Option for Sensitive Coil:**

H = 8A Contacts (Only available with Coil Input/Contact Rating code "L").

**8. Suffix:**

,000 = Standard model for enclosure code "SS"      ,095 = Standard model for enclosure code "SH"      Other Suffix = Custom model

\* Not suitable for immersion cleaning processes.

\*\* For higher contact rating with sensitive coil, add suffix "H" to the end of the part number as indicated in step 7 of Ordering Information.

**Our authorized distributors are more likely to stock the following items for immediate delivery.**

- |                  |                  |                   |                   |
|------------------|------------------|-------------------|-------------------|
| OJ-SH-105HM,095  | OJE-SH-105DM,095 | OJE-SH-112HM,095  | OJE-SH-124LMH,095 |
| OJ-SH-112LMH,095 | OJE-SH-112DM,095 | OJE-SH-105LMH,095 |                   |
| OJ-SH-124LMH,095 | OJE-SH-124DM,095 | OJE-SH-112LMH,095 |                   |

**Outline Dimensions**

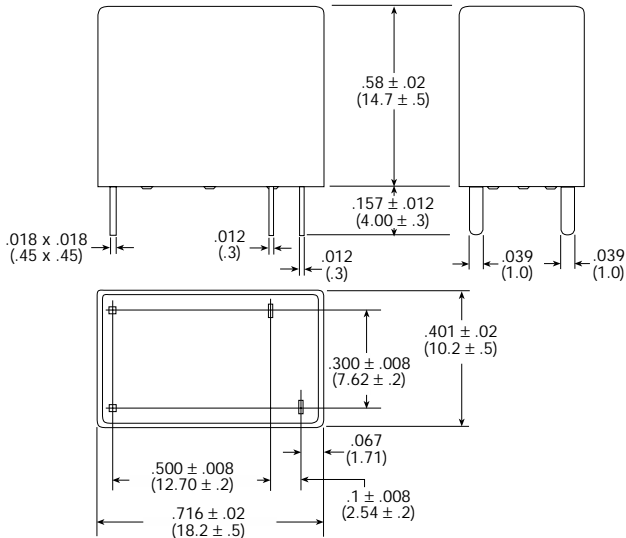

**Wiring Diagram (Bottom View)**

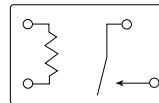

**PC Board Layout (Bottom View)**

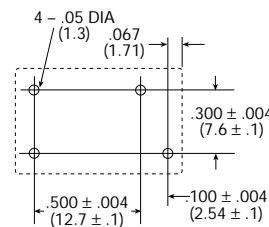

**Reference Data**

**Coil Temperature Rise**

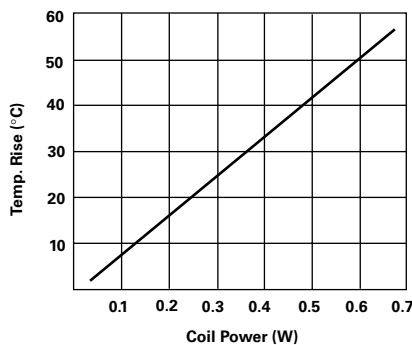

**Operate Time**

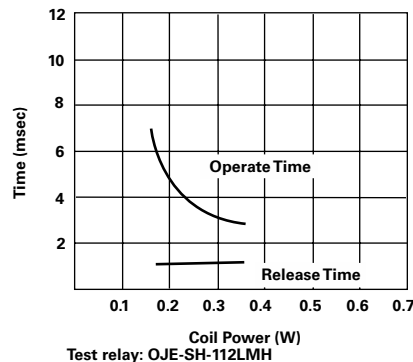

**Life Expectancy**

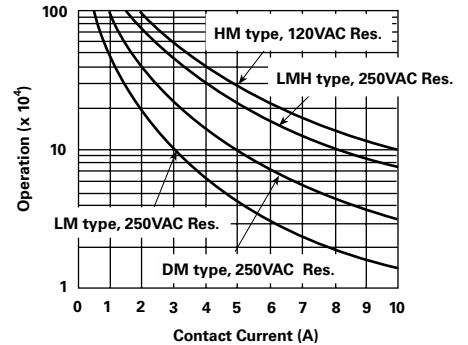

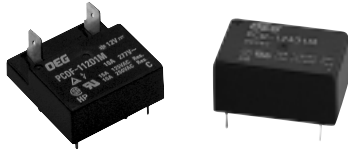

# PCD/PCDF series

## 15 Amp Low Profile Power PC Board Relay

Appliances, HVAC, Office Machines

UL File No. E82292

CSA File No. LR48471

TUV File No. R9751117

Users should thoroughly review the technical data before selecting a product part number. It is recommended that user also seek out the pertinent approvals files of the agencies/laboratories and review them to ensure the product meets the requirements for a given application.

### Features

- Low profile (10mm), 15 Amp switching capacity.
- 1 Form A contact arrangement.
- Sensitive 200mW coil (250mW on 48VDC coil).
- Immersion cleanable, sealed version available.
- Quick connect terminals available (PCDF).

### Contact Data @ 20°C

**Arrangements:** 1 Form A (SPST-NO).

**Material:** AgSnO.

**Max. Switching Rate:** 300 ops./min. (no load).  
30 ops./min. (rated load).

**Expected Mechanical Life:** 10 million operations (no load).

**Expected Electrical Life:** 100,000 operations (rated load).

**Minimum Load:** 100mA @ 5VDC.

**Initial Contact Resistance:** 100 milliohms @ 1A, 6VDC.

### Contact Ratings

**Ratings:** 15A @ 125VAC resistive (PCDF only, load must be carried through QC terminals to achieve this rating),  
10A @ 250VAC resistive,  
10A @ 24VDC resistive.

5A @ 125VAC inductive (cos $\phi$ = 0.4, L/R=7msec),  
5A @ 24VDC inductive (cos $\phi$ = 0.4, L/R=7msec).

**Max. Switched Voltage:** **AC:** 250V.  
**DC:** 24V.

**Max. Switched Current:** 15A.  
**Max. Switched Power:** 1,800VA, 240W.

### Initial Dielectric Strength

**Between Open Contacts:** 750VAC 50/60 Hz. (1 minute).

**Between Coil and Contacts:** 2,500VAC 50/60 Hz. (1 minute).

**Surge Voltage Between Coil and Contacts:** 5,000V (1.2 / 50 $\mu$ s).

### Initial Insulation Resistance

**Between Mutually Insulated Elements:** 1,000M ohms min. @ 500VDCM.

### Coil Data

**Voltage:** 5 to 48VDC.

**Nominal Power:** 200 mW except 48VDC coil (250mW).

**Coil Temperature Rise:** 20°C max., at rated coil voltage.

**Max. Coil Power:** 130% of nominal.

**Duty Cycle:** Continuous.

### Coil Data @ 20°C

PCD & PCDF				
Rated Coil Voltage (VDC)	Nominal Current (mA)	Coil Resistance (ohms) $\pm$ 10%	Must Operate Voltage (VDC)	Must Release Voltage (VDC)
5	40.0	125	3.75	0.50
6	33.3	180	4.50	0.60
9	22.5	400	6.75	0.90
12	17.0	720	9.00	1.20
24	8.6	2,880	18.00	2.40
48	5.2	9,200	36.00	4.80

### Operate Data

**Must Operate Voltage:** 75% of nominal voltage or less.

**Must Release Voltage:** 10% of nominal voltage or more.

**Operate Time:** 15 ms max.

**Release Time:** 8 ms max.

### Environmental Data

**Temperature Range:**

**Operating:** -30°C to +70°C

**Vibration, Mechanical:** 10 to 55 Hz., 1.5mm double amplitude

**Operational:** 10 to 55 Hz., 1.5mm double amplitude.

**Shock, Mechanical:** 1,000m/s<sup>2</sup> (10G approximately).

**Operational:** 100m/s<sup>2</sup> (10G approximately).

**Operating Humidity:** 20 to 85% RH. (Non-condensing).

### Mechanical Data

**Termination:** **PCD:** Printed circuit terminals.

**PCDF:** Printed circuit terminals and quick connect terminals.

**Enclosure (94V-0 Flammability Ratings):** Sealed plastic case.

**Weight:** **PCD:** 0.31 oz (9g) approximately.

**PCDF:** 0.35 oz (10g) approximately.

**Ordering Information**

Typical Part Number ▶

**PCD -1 24 D 1 M H ,000**

**1. Basic Series:**

PCD = PC Board Terminals. PCDF = Quick Connect Terminals.

**2. Termination:**

1 = 1 pole

**3. Coil Voltage:**

05 = 5VDC      09 = 9VDC      24 = 24VDC  
06 = 6VDC      12 = 12VDC      48 = 48VDC

**4. Coil Input:**

D = Standard

**5. Contact Material:**

1 = AgSnO

**6. Contact Arrangement:**

M = 1 Form A, SPST-NO

**7. Enclosure:**

Blank = Vented (Flux-tight)\* plastic cover      H = Sealed plastic case

**8. Suffix:**

,000 = PCD standard model      ,S000 = PCDF standard model      Other Suffix = Custom model

\* Not suitable for immersion cleaning processes.

**Our authorized distributors are more likely to maintain the following items in stock for immediate delivery.**  
None at present.

**Outline Dimensions**

**PCD**

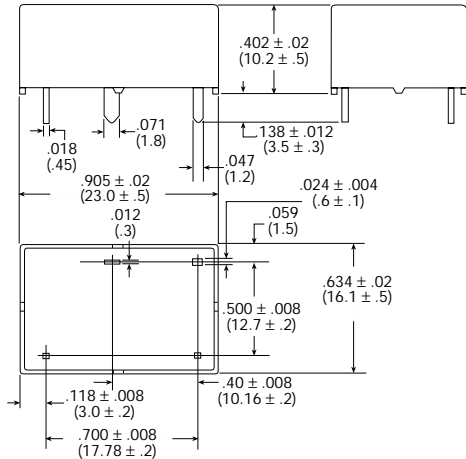

**PCDF**

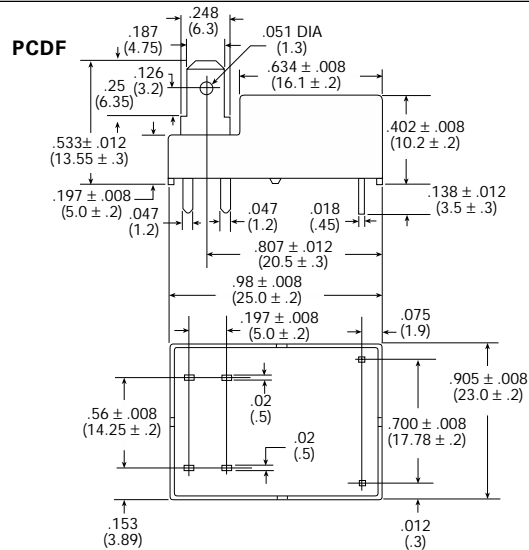

**Wiring Diagrams**

**PCD**

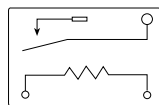

(Bottom View)

**PCDF**

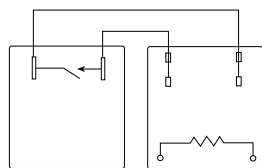

(Top View)

(Bottom View)

**PC Board Layouts (Bottom View)**

**PCD**

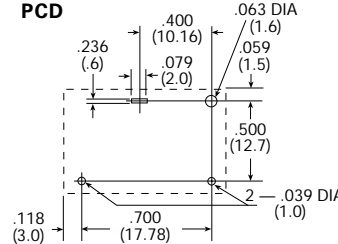

**PCDF**

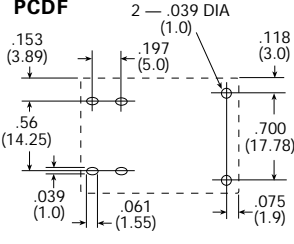

**Reference Data**

**Coil Temperature Rise**

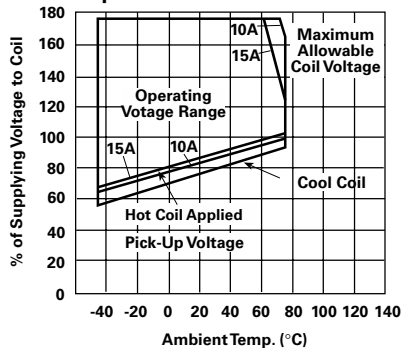

Note: This data is based on the max. allowable temperature for E type insulation coil (115°C).

**Operate Time**

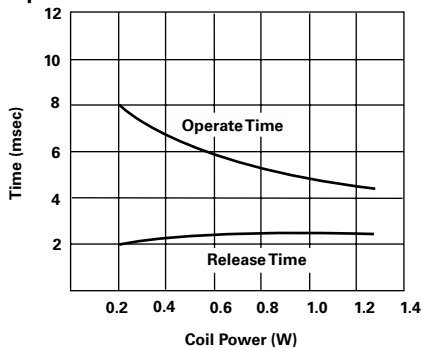

**Life Expectancy**

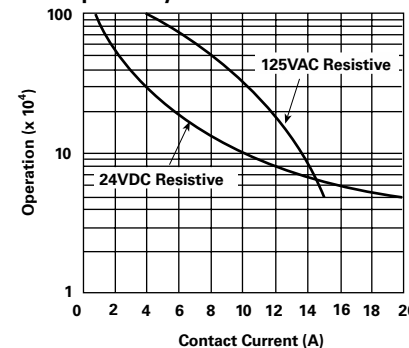



# PB series

## 10 Amp, PC Board Miniature Relay

File E214025

File 4570-4940-0042

Users should thoroughly review the technical data before selecting a product part number. It is recommended that user also seek out the pertinent approvals files of the agencies/laboratories and review them to ensure the product meets the requirements for a given application.

### Features

- Small size for high density PC board mounting.
- 1 Form A and 1 Form C contact arrangements.
- Creepage/clearance to VDE 0435 and VDE 0700.
- 2,500Vrms dielectric strength between contact and coil.
- UL Class F approved insulation system.
- Low-complexity design for enhanced reliability.
- High-temperature version available.

### Contact Data

**Arrangements:** 1 Form A (SPST-NO) and 1 Form C (SPDT).  
**Material:** Silver nickel 90/10.

**Max. Switching Rate:** 6,000 ops./min. (minimum load).  
600 ops./min. (rated load).

**Expected Mechanical Life:** 5 million operations.

#### Expected Electrical Life :

- PB1 & PB3 @85°C:** 100,000 operations @ 6A, 240VAC (NO).  
25,000 operations @ 10A, 240VAC (NO).  
25,000 operations @ 10A/3A, 240VAC (NO/NC).  
1,000 operations @ 10A/10A, 240VAC (NO/NC).
- PBH @105°C:** 250,000 operations @ 2A, 240VAC (NO).  
150,000 operations @ 5A, 240VAC (NO).  
100,000 operations @ 6A/6A, 240VAC (NO/NC).

**Maximum Contact Rating:** **PB1 & PB3:** NO (Make) 10A / NC (Break) 3A.  
**PBH:** 6A (mtg. space 3mm); 4A (dense pack).

**Maximum Switching Voltage:** **PB1 & PB3:** 250VAC, 100 VDC.  
**PBH:** 250VAC

**Maximum Make Current (All):** 15A (max. 4 sec at 10% duty cycle.)

#### Maximum Breaking Capacity:

- PB1 & PB3:** 750VA (NC contact) / 2,500VA (NO contact).  
**PBH:** 1,500VA.

### Initial Dielectric Strength

- Between Open Contacts:** 1,000Vrms.  
**Between Coil and Contacts:** 2,500Vrms.  
**Surge Voltage Resistance Between Coil and Contacts:** 4,000Vrms.  
**Clearance / Creepage Distance:** 3 mm / 4 mm.

### Initial Insulation Resistance

- Between Mutually Insulated Elements:** 10<sup>8</sup> ohms.  
**Tracking Resistance of Relay Base:** **PB1:** CTI 250  
**PB3:** CTI 300  
**Insulation to VDE 0110b (2/79):** Category C / Reference Voltage 250.

### Coil Data @ 20°C

- Voltage:** 5, 6, 9, 12, 24 and 36VDC.  
**Nominal Coil Power:** 360mW.  
**Operate Coil Power:** 200mW.

### Coil Data @ 20°C

Rated Coil Voltage (VDC)	Coil Resistance ±10% (ohms)	Must Operate Voltage (VDC)	Must Release Voltage (VDC)	Coil Current (mA)
5	70	3.75	0.5	72.0
6	100	4.5	0.6	60.0
9	225	6.75	0.9	40.0
12	400	9.0	1.2	30.0
24	1,600	18.0	2.4	15.0
36	3,600	27.0	3.6	60.0

### Operate Data @ 20°C

- Operate/Release Time:** 20 ms, max. (excluding bounce).  
**Bounce Time:** 15 ms, max.  
**Operate Coil Power:** 200mW.

### Environmental Data

**Temperature Range (Operating):** **PB1 or PB3:** -40°C to +85°C.  
**PBH:** -20°C to +105°C.

**Vibration:** 30 to 400 Hz., 4g's, min.

**Shock: Mechanical (Destruction):** 30g min.

**Protection Category:** IP 54

### Mechanical Data

- Termination:** Printed circuit board.  
**Enclosure:** Splash-resistant (unsealed) plastic case (UL Flammability Class V-0).  
**Weight:** 0.2 oz. (5.4g).

### Contact Life (PB1 & PB3)

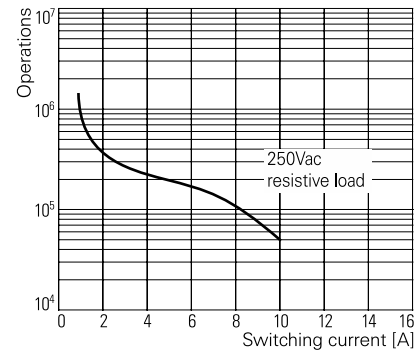

### Max. DC Load Breaking Capacity (PB1 & PB3)

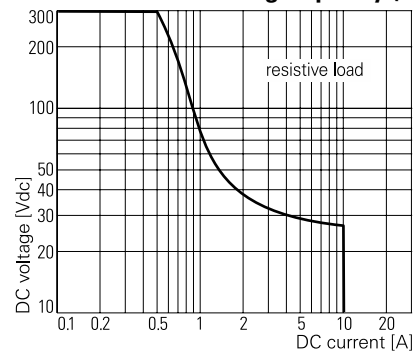

### Coil Operating Range (PB1 & PB3)

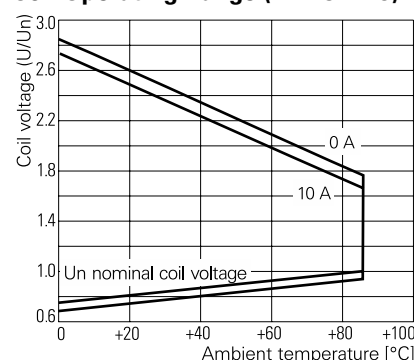

**Ordering Information**

<b>Typical Part Number ▶</b>						<b>PB</b>	<b>1</b>	<b>3</b>	<b>4</b>	<b>012</b>
<b>1. Basic Series:</b> PB = Miniature, 10A PC board relay.										
<b>2. Version:</b> 1 = Standard version, CTI 250      3 = High CTI version, CTI 300      H = High Temperature (105°C) version, CTI 250										
<b>3. Contact Arrangement:</b> 1 = 1 Form C (SPDT)      3 = 1 Form A (SPST-NO)										
<b>4. Contact Material:</b> 4 = AgNi 90/10										
<b>4. Coil Input:</b> 005 = 5VDC      006 = 6VDC      009 = 9VDC      012 = 12 VDC      024 = 24VDC      036 = 36VDC      (Other voltages available as special order)										

**Our authorized distributors are more likely to maintain the following items in stock for immediate delivery.**

PB114012  
PB114024

**Outline Dimensions**

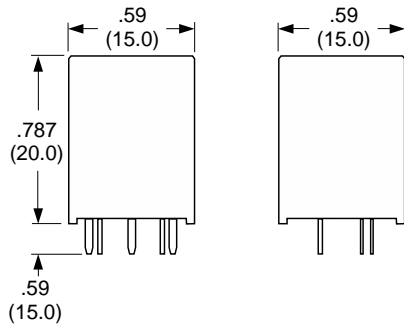

**Wiring Diagram (Bottom View)**

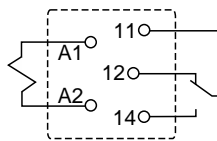

**Suggested PC Board Layout (Bottom View)**

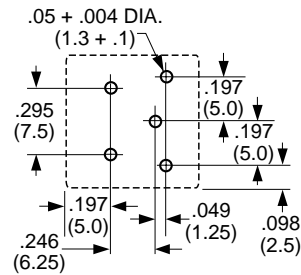



# V23148 (U/UB) series

## 7 Amp, Latching or Non-latching, Miniature Printed Circuit Board Relay

UL File E214025

Users should thoroughly review the technical data before selecting a product part number. It is recommended that users also seek out the pertinent approvals files of the agencies/laboratories and review them to ensure the product meets the requirements for a given application.

### Features

- 1 Form A (SPST-NO), 1 Form B (SPST-NC) and 1 Form C (SPDT).
- 8 amp rated current.
- Standard (non-latching) or latching types.
- Sensitive model requires 180mW to pull-in.
- 2,000Vrms and 4,000Vrms contact-to-coil dielectric versions.
- Washable (sealed) plastic case.

### Operate Data

**Must Operate Voltage:** See Coil Data table.  
**Operate Time:** 6 ms, standard model; 7 ms, sensitive model; 5 ms, latching model.  
**Release (Reset) Time:** 3 ms.  
**Bounce Time (N/O contact / N/C contact) :** 2 ms / 10ms.  
**Switching Rate:** 180,000 ops./hr. max. at rated load.

### Environmental Data

**Temperature Range:**  
**Operating:** -25°C to +70°C.  
**Vibration:** (10 to 55 Hz.) 10g.  
**Shock (functional):** 10g at 11ms, half-sine.

### Mechanical Data

**Termination:** Printed circuit terminals.  
**Enclosure (94 V-0 rated):** Sealed (RTIII) plastic case.  
**Weight:** 0.34 oz. (9.5 g) approximately.

### Max. DC Load Breaking Capacity

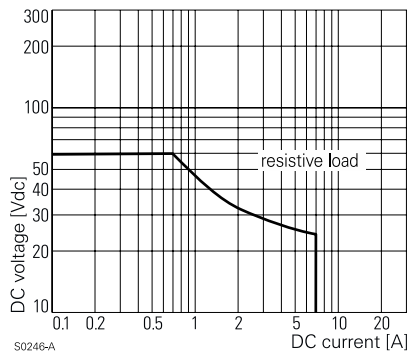

### Coil Operating Range

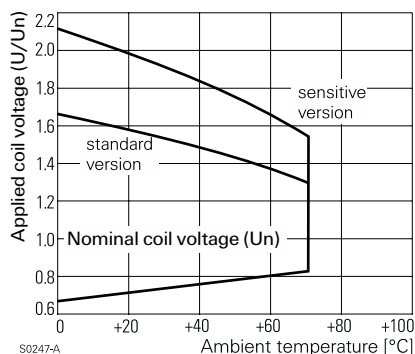

### Contact Data @ 70°C

**Arrangements:** 1 Form A (SPST-NO) and 1 Form C (SPDT), single contact.  
**Material:** Silver-nickel 0.15.

**Expected Mechanical Life:** 20 million operations.

#### Ratings:

- Current:** 7A, standard and latching types; 5A, sensitive type.  
**Voltage:** 250VAC.  
**Power (breaking):** 1,750 VA standard and latching; 1,250 VA, sensitive.  
**Voltage (breaking):** 250VAC.  
**Current (making, max. 4s at 10% duty cycle):** 12A.  
**Standard Type**  
 7 amp resistive, 24VDC or 250VAC, 50,000 ops  
 5 amp resistive, 250VAC, 150,000 ops.  
**Latching Type**  
 7 amp resistive, 24VDC or 250VAC, 50,000 ops.  
 5 amp resistive, 250VAC, 100,000 ops.  
**Sensitive Type**  
 5 amp resistive, 250VAC, 100,000 ops.  
 5 amp resistive, 24VDC, 30,000 ops.

### Initial Dielectric Strength

**Between Open Contacts:** 1,000Vrms.  
**Between Coil and Contacts:** 2,000Vrms for standard dielectric version.  
 4,000Vrms for high dielectric version.  
**Creepage/Clearance:** 2.5/2.5mm for standard dielectric version.  
 3.5/3.5mm for high dielectric version.  
**Surge Resistance Between Coil and Contacts:** 5,000Vrms.

### Coil Data DC @ 20°C

**Nominal Coil Power:** 330 - 800mW, dependent upon model.

Nominal Voltage VDC	DC Resistance in Ohms ±10%	Must Operate Voltage VDC	Drop-out Voltage VDC	Maximum Voltage VDC	Nominal Coil Current (mA)
<b>Standard, non-latching models</b>					
6	80	4.2	0.6	10.5	75.0
12	320	8.4	1.2	21.1	37.5
24	1,280	16.8	2.4	42.2	18.8
48	3,800	33.6	4.8	72.4	5.0
<b>Sensitive, non-latching models</b>					
6	110	4.4	0.6	12.6	54.6
12	440	8.8	1.2	25.3	27.3
24	1,780	17.5	2.4	50.6	13.5
48	4,000	35.0	4.8	76.3	12.0
Nominal Voltage VDC	DC Resistance in Ohms ±10%	Must Operate Voltage VDC	Reset Voltage VDC	Maximum Voltage VDC	Nominal Coil Current (mA)
<b>Latching models</b>					
6	33	4.7	1.5	6.2	181.8
12	119	9.4	3.0	12.4	100.8
24	475	18.7	6.0	24.7	50.5
48	1,750	37.4	12.0	49.4	27.4

**Ordering Information**

Typical Part Number ►

**V23148 -A 0 0 03 -C 101**

- 1. Basic Series:**  
V23148 = U/UB miniature printed circuit board relay.
- 2. Version**  
A = Non-latching.      B = Latching.
- 3. Dielectric Strength, Coil-to-Contacts:**  
0 = 2,000Vrms.      1 = 4,000Vrms.
- 4. Coil Sensitivity:**  
0 = Standard.      1 = Sensitive (Not available on latching version).
- 5. Coil Voltage:**  
03 = 6VDC      05 = 12VDC      07 = 24VDC      08 = 48VDC
- 6. Contact Arrangement:**  
A = 1 Form C (SPDT)      B = 1 Form A (SPST-NO)      C = 1 Form B (SPST-NC)
- 7. Contact Material:**  
101 = Silver-nickel 0.15

**Our authorized distributors are more likely to maintain the following items in stock for immediate delivery.**

None at present.

**Outline Dimensions**

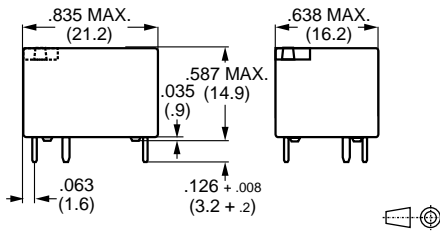

**PC Board Layout (Bottom View)**

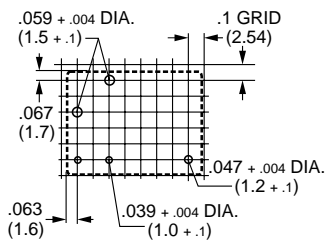

**Wiring Diagrams (Bottom Views)**

**1 Form C**

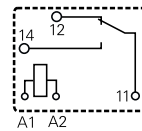

**1 Form A**

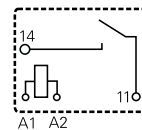

**1 Form B**

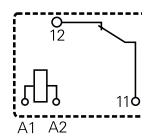

# T73 series

## Low Profile, 10 Amp Printed Circuit Board Relay



File E29244

File LR48471

Users should thoroughly review the technical data before selecting a product part number. It is recommended that user also seek out the pertinent approvals files of the agencies/laboratories and review them to ensure the product meets the requirements for a given application.

### Features

- 10 amp switching capacity.
- UL Class F (155°C) coil insulation system standard.
- 1 Form A and 1 Form C contact arrangements.
- Ideal for domestic appliances, HVAC and security.
- Resists high temperature and various chemical solutions.
- Immersion cleanable, plastic sealed case available.

### Contact Data @ 20°C

**Arrangements:** 1 Form A (SPST-NO) and 1 Form C (SPDT).

**Material:** Silver-cadmium oxide.

**Max. Switching Rate:** 240 ops./min. (no load).  
30 ops./min. (rated load).

**Expected Mechanical Life:** 10 million operations.

**Expected Electrical Life:** 100,000 operations.

**Minimum Load:** 10mA @ 5VDC

**Initial Contact Resistance:** 100 milliohms max. @ 100mA, 6VDC.

**Contact Ratings @ 20°C with relay properly vented. Remove vent nib after soldering and cleaning.**

Contact Arrang.	Typical Ratings	Type	Operations
1 & 5	1/3HP NO @ 240VAC	Motor	30,000
	10A NO @ 120VAC	Resistive	100,000
	6A NO @ 120VAC	Resistive	100,000
	6A NO @ 24VDC	Resistive	100,000
	10A/5A @ 120VAC	Resistive	100,000
	1/4HP NO @ 120VAC	Motor	100,000

Consult factory for other ratings.

### Initial Dielectric Strength

**Between Open Contacts:** 750VAC 50/60 Hz. (1 minute).

**Between Coil and Contacts:** 2,000VAC 50/60 Hz. (1 minute).

### Initial Insulation Resistance

**Between Mutually Insulated Elements:** 10<sup>8</sup> ohms min. @ 500VDC.  
Ag contact rating.

### Coil Data @ 20°C

**Voltage:** 3 to 48VDC.

**Nominal Power:** 450 milliwatts.

660 milliwatts for 48VDC coil.

**Coil Temperature Rise:** 35°C max, at rated coil voltage.

**Max. Coil Power:** 130% of nominal.

**Duty Cycle:** Continuous.

### Coil Data @ 20°C

Rated Coil Voltage (VDC)	Coil Resistance (Ohms) +10%	Must Operate Voltage (VDC)	Must Release Voltage (VDC)
3	20	1.95	0.15
5	56	3.25	0.25
6	80	3.90	0.30
9	180	5.85	0.45
12	320	7.80	0.60
18	720	11.7	0.90
24	1,150	15.6	1.20
48	3,500	31.2	2.40

### Operate Data @ 20°C

**Operate Time:** 10 ms (excluding bounce).

**Release Time:** 5 ms (excluding bounce).

### Environmental Data

**Temperature Range:**

**Storage:** -40°C to +130°C.

**Operating:** -30°C to +80°C.

**Vibration, Mechanical:** 10 to 55 Hz., 1.5mm double amplitude

**Operational:** 10 to 55 Hz., 1.5mm double amplitude.

**Shock, Mechanical:** 100g min.

**Operational:** 10g min.

**Operating Humidity:** 45 to 85% RH.

### Mechanical Data

**Termination:** Printed circuit terminals.

**Enclosure (94V-0 Flammability Ratings):**

**Weight:** 0.42 oz. (12g).

Figure 1 - Coil Temperature Rise

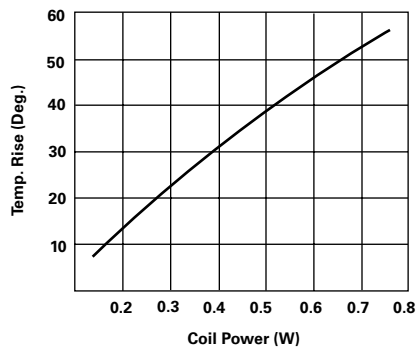

Operate Time

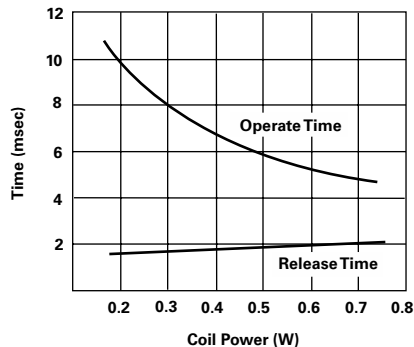

Life Expectancy

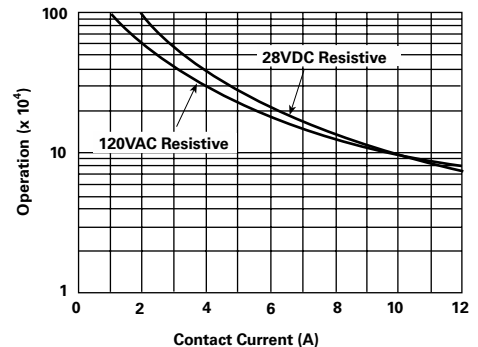

Note: Graphical data should not be used as a substitute for specific application verification. To be used for estimates only.

Ordering Information

Typical Part Number ▶

T73

S

5

D

1

5

-24

1. Basic Series:

T73 = Miniature, printed circuit board relay.

2. Enclosure:

V = Vented (Flux-tight)\*

S = Immersion cleanable, plastic sealed case.

3. Contact Arrangement:

1 = 1 Form A (SPST-NO).

5 = 1 Form C (SPDT)

4. Coil Input:

D = DC voltage.

5. Relay Type:

1 = Standard coil.

6. Contact Material:

5 = Silver-Cadmium Oxide

7. Coil Voltage:

03 = 3VDC 06 = 6VDC 12 = 12VDC 24 = 24VDC

05 = 5VDC 09 = 9VDC 18 = 18VDC 48 = 48VDC

\* Not suitable for immersion cleaning process.

Our authorized distributors are more likely to maintain the following items in stock for immediate delivery.

T73S5D15-05

T73S5D15-12

T73S5D15-24

Outline Dimensions

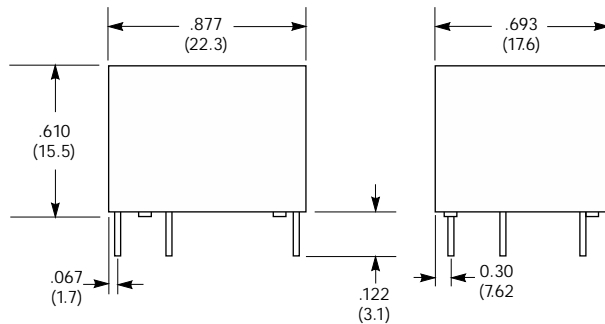

Wiring Diagrams (Bottom Views)

1 Form A

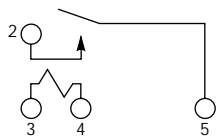

1 Form C

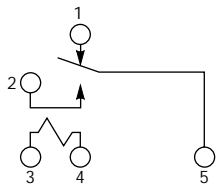

Suggested PC Board Layouts (Bottom Views)

1 Form A

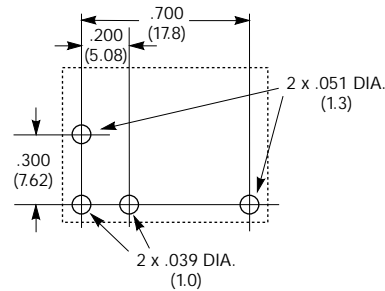

1 Form C







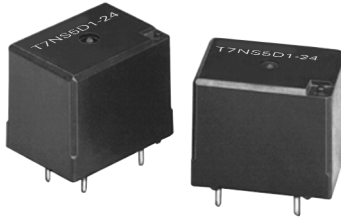

# T7N series

## 10 Amp Miniature PC Board Relay

File E22575

File LR48471



Users should thoroughly review the technical data before selecting a product part number. It is recommended that user also seek out the pertinent approvals files of the agencies/laboratories and review them to ensure the product meets the requirements for a given application.

### Features

- Low cost, reduced height, 10A relay.
- 1 Form A and 1 Form C contact arrangement.
- Plastic materials employ UL 94V-0 flammability.
- UL class F (155°C) coil standard.
- Immersion cleanable, sealed package.
- Applications include appliance, HVAC, security system, garage opener light, emergency lighting.
- European "white goods" version available by special order.

### Contact Data @ 20°C

**Arrangements:** 1 Form A (SPST-NO) and 1 Form C (SPDT).

**Material:** Silver-cadmium oxide.

**Max. Switching Rate:** **Mechanical:** 300 operations/min.

**Electrical:** 30 operations/min.

**Expected Mechanical Life:** 10 million operations min. (no load).

**Expected Electrical Life:** 100,000 operations min. (at rated coil voltage).

**Minimum Contact Load:** 10mA @ 5VDC.

**Initial Contact Resistance:** 100 milliohms, max. @ 1A, 6VDC.

**UL Contact Ratings @ 20°C with relay properly vented. Remove vent nib after soldering and cleaning.**

Contact Arrang.	UL/CSA Ratings	Type	Operations
1 & 5	1/4HP @ 240VAC	Motor	1,000*
	1/3HP @ 120VAC	Motor	6,000
	1/3HP NO @ 120VAC	Motor	6,000
	1/3HP NO @ 240VAC	Motor	6,000**
	5A/5A @ 240VAC	Resistive	6,000*
	10A NO @ 240VAC	Resistive	6,000
	10A/5A @ 240VAC	Gen. Purpose	6,000
	8A NC @ 240VAC	Resistive	6,000
	1/6HP NC @ 240VAC	Motor	6,000**
	1/4HP NO @ 240VAC	Motor	6,000**
	1/10HP NO @ 120VAC	Motor	6,000**
	10A/5A @ 240VAC	Resistive	6,000**
	TV-3 NO @ 120VAC	Tungsten	25,000
	6A NC @ 240VAC	Resistive	25,000**
	10A/5A @ 240VAC	Resistive	30,000
	10A/5A @ 28VDC	Resistive	30,000
	10A NO @ 240VAC	Resistive	30,000**
	10A NO @ 240VAC	Gen. Purpose	30,000**
	34.8LRA/6FLA NO @ 120VAC	Motor	100,000
	10A/5A @ 120VAC	Resistive	100,000
5A/5A @ 240VAC	Resistive	100,000	
10A/5A @ 28VDC	Resistive	100,000	

\*Denotes test at 70°C ambient temperature.

\*\*Denotes test at 85°C ambient temperature.

### Initial Dielectric Strength

**Between Open Contacts:** 750VAC, 50/60 Hz. (1 min.)

**Between Coil and Contacts:** 2,000VAC, 50/60 Hz. (1 min.)

### Initial Insulation Resistance

**Between Mutually Insulated Elements:** 10<sup>8</sup> ohms, min. @ 500VDC.

### Coil Data

**Voltage:** 3 through 48VDC.

**Nom. Power:** 360mW.

**Coil Temp. Rise:** See Figure 1.

**Max. Coil Power:** 150% of nominal.

**Duty Cycle:** Continuous.

### Coil Data @ 20°C

Rated Coil Voltage (VDC)	Coil Resistance ±10% (Ohms)	Must Operate Voltage (VDC)	Must Release Voltage (VDC)
3	25	2.1	.15
5	70	3.5	.25
6	100	4.2	.30
9	225	6.3	.45
12	400	8.4	.60
18	900	12.6	.90
24	1,600	16.8	1.20
36	3,600	25.2	1.80
48	6,400	33.6	2.40

### Operate Data @ 20°C

**Operate Time:** 10 ms, max. (excluding bounce).

**Release Time:** 5 ms, max. (excluding bounce).

### Environmental Data

**Temperature Range:**

**Storage:** -40°C to +130°C.

**Operating:** -40°C to +85°C. (no water condensation and no water drop).

**Vibration:** 10-55 Hz., .063" (1.6mm) double amplitude;  
10-55 Hz., .079" (2.0mm) double amplitude.

**Shock: Mechanical:** 100g minimum.

**Operational:** 10g minimum.

**Operating Humidity:** 45 to 85% RH.

### Mechanical Data

**Termination:** Printed circuit terminals.

**Enclosure (UL 94V-0 Flammability Ratings):**

**T7NS:** Immersion cleanable case with knock-off nib for ventilation.

**T7NV:** Vented, flux-tight plastic cover.

**Weight:** 0.38 oz. (11g) approximately.

**Figure 1 – Coil Temperature Rise**

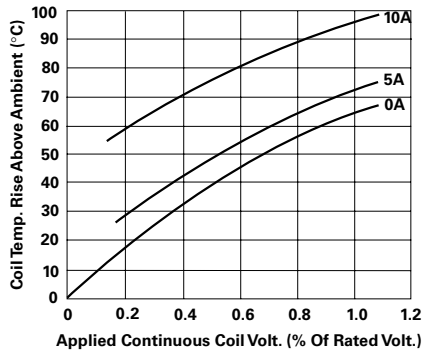

**Operate Time**

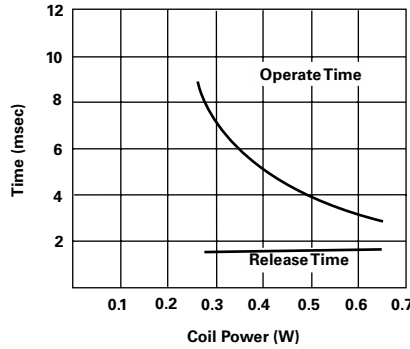

**Life Expectancy**

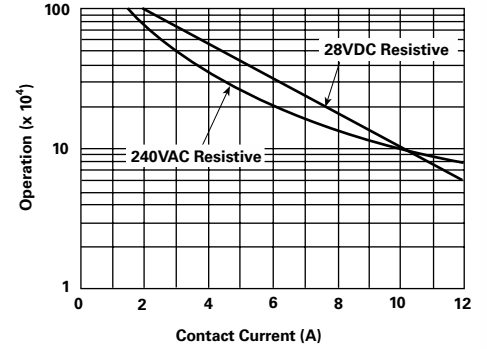

**Note:** Graphical data should not be used as a substitute for specific application verification. To be used for estimates only.

**Ordering Information**

Typical Part Number ▶ **T7N S 5 D 1 -24**

- Basic Series:**  
T7N = Miniature, printed circuit board relay.
- Enclosure:**  
V = Vented, flux-tight\* S = Immersion cleanable case with knock-off nib.
- Contact Arrangement:**  
1 = 1 Form A(SPST-NO) 5 = 1 Form C (SPDT)
- Coil Input:**  
D = DC Coil.
- Contact Material:**  
1 = Silver-cadmium oxide contacts.
- Coil Voltage:**  
03 = 3VDC 06 = 6VDC 12 = 12VDC 24 = 24VDC 48 = 48VDC  
05 = 5VDC 09 = 9VDC 18 = 18VDC 36 = 36VDC

\* Not suitable for immersion cleaning.

**Our authorized distributors are more likely to maintain the following items in stock for immediate delivery.**

- T7NS1D1-12 T7NS5D1-05 T7NS5D1-24
- T7NS1D1-24 T7NS5D1-12 T7NS5D1-48

**Outline Dimensions**

Tolerance (unless otherwise noted): 3 decimal: ±.010 (±.254); 2 decimal: ±.015 (±.381).

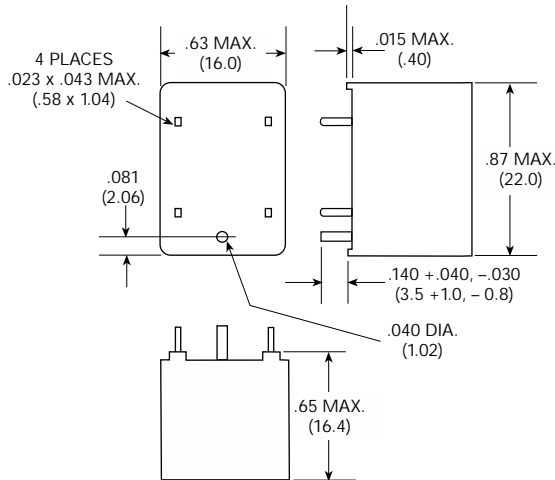

**Suggested PC Board Layout (Bottom View)**

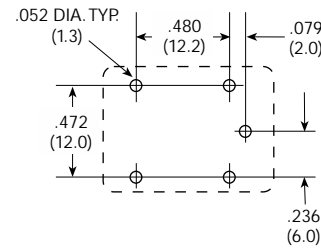

**Socket**

**27E1064** socket is rated 10A @ 300VAC. UL Recognized for US and Canada. Designed to fit same suggested board layout as relay.

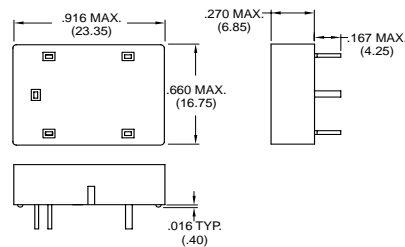

**Wiring Diagram (Bottom View)**

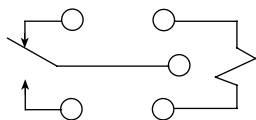



# PCE series

## 10 Amp Miniature Power PC Board Relay

Appliances, HVAC, Office Machines

UL File No. E82292

CSA File No. LR48471

VDE File No. 6175

Users should thoroughly review the technical data before selecting a product part number. It is recommended that user also seek out the pertinent approvals files of the agencies/laboratories and review them to ensure the product meets the requirements for a given application.

### Features

- Small, low profile package, 10 Amp switching capacity.
- 1 Form A and 1 Form C contact arrangements.
- UL Class F (155°C) insulation system standard
- Immersion cleanable, sealed version available.
- Applications include appliance, HVAC, security system, garage opener control, emergency lighting.

### Contact Data @ 20°C

**Arrangements:** 1 Form A (SPST-NO) and 1 Form C (SPDT).

**Material:** Ag Alloy, AgSnO.

**Max. Switching Rate:** 300 ops./min. (no load).  
30 ops./min. (rated load).

**Expected Mechanical Life:** 10 million operations (no load).

**Expected Electrical Life:** 100,000 operations (rated load).

**Minimum Load:** 100mA @ 5VDC.

**Initial Contact Resistance:** 100 milliohms @ 1A, 6VDC.

### Contact Ratings

**Ratings:** 10A @ 250VAC resistive,  
10A @ 120VAC resistive,  
10A @ 28VDC resistive.

3A @ 250VAC inductive (cosφ= 0.4),  
3A @ 120VAC inductive (cosφ= 0.4),  
3A @ 28VDC inductive (L/R=7msec).

**Max. Switched Voltage:** AC: 250V.  
DC: 28V.

**Max. Switched Current:** 10A.

**Max. Switched Power:** 2,500VA, 280W.

### Initial Dielectric Strength

**Between Open Contacts:** 750VAC 50/60 Hz. (1 minute).

**Between Coil and Contacts:** 2,000VAC 50/60 Hz. (1 minute).

**Surge Voltage Between Coil and Contacts:** 4,000V (1.2 / 50μs).

### Initial Insulation Resistance

**Between Mutually Insulated Elements:** 1,000M ohms min. @ 500VDCM.

### Coil Data

**Voltage:** 6 to 48VDC.

**Nominal Power:** 360 mW

**Coil Temperature Rise:** 35°C max., at rated coil voltage.

**Max. Coil Power:** 130% of nominal.

**Duty Cycle:** Continuous.

### Coil Data @ 20°C

PCE				
Rated Coil Voltage (VDC)	Nominal Current (mA)	Coil Resistance (ohms) ± 10%	Must Operate Voltage (VDC)	Must Release Voltage (VDC)
6	60	100	4.50	0.30
9	40	225	6.75	0.45
12	30	400	9.00	0.60
24	15	1,600	18.00	1.20
48	7	6,400	36.00	2.40

### Operate Data

**Must Operate Voltage:** 75% of nominal voltage or less.

**Must Release Voltage:** 5% of nominal voltage or more.

**Operate Time:** 10 ms max.

**Release Time:** 5 ms max.

### Environmental Data

**Temperature Range:**

**Operating:** -30°C to +70°C

**Vibration, Mechanical:** 10 to 55 Hz., 1.5mm double amplitude

**Operational:** 10 to 55 Hz., 1.5mm double amplitude.

**Shock, Mechanical:** 1,000m/s<sup>2</sup> (100G approximately).

**Operational:** 100m/s<sup>2</sup> (10G approximately).

**Operating Humidity:** 20 to 85% RH. (Non-condensing).

### Mechanical Data

**Termination:** Printed circuit terminals.

**Enclosure (94V-0 Flammability Ratings):**

**PCE:** Sealed plastic case with knock-off nib for ventilation

**Weight:** 0.32 oz (11g) approximately.

### Reference Data

#### Coil Temperature Rise

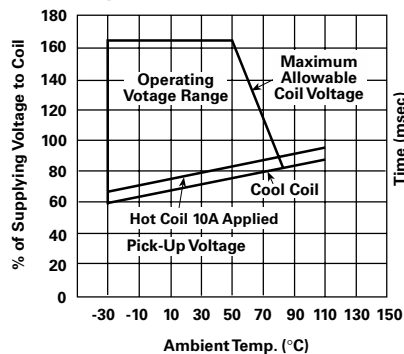

**Note:** This data is based on the max. allowable temperature for E type insulation coil (115°C).

#### Operate Time

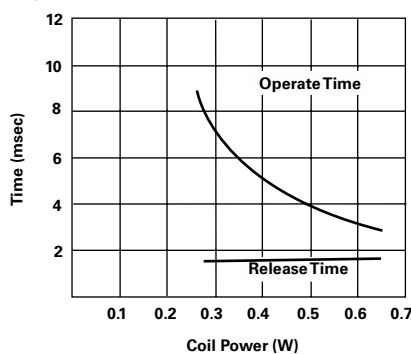

#### Life Expectancy

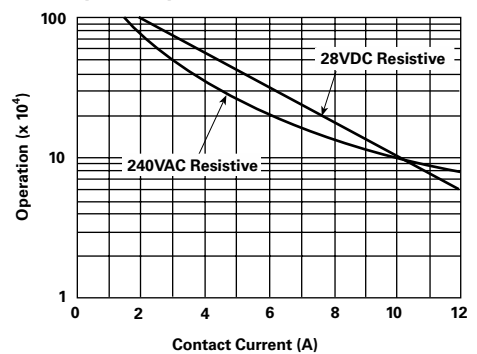

**Ordering Information**

<b>Typical Part Number</b> ▶	<b>PCE</b>	<b>-1</b>	<b>24</b>	<b>D</b>	<b>1</b>	<b>M</b>	<b>,000</b>
<p><b>1. Basic Series:</b> PCE = Miniature Power PC board relay.</p>							
<p><b>2. Termination:</b> 1 = 1 pole</p>							
<p><b>3. Coil Voltage:</b> 06 = 6VDC      12 = 12VDC      48 = 48VDC 09 = 9VDC      24 = 24VDC</p>							
<p><b>4. Coil Input:</b> D = Standard</p>							
<p><b>5. Contact Material:</b> 1 = AgCdO      2 = AgSnO</p>							
<p><b>6. Contact Arrangement:</b> Blank = 1 Form C, SPDT      M = 1 Form A, SPST-NO</p>							
<p><b>7. Enclosure:</b> Blank = Flux-tight plastic case.      H = Sealed plastic case with knock-off nib for ventilation</p>							
<p><b>8. Suffix:</b> ,000 = Standard model      Other Suffix = Custom model</p>							

**Our authorized distributors are more likely to maintain the following items in stock for immediate delivery.**

PCE-112D1MH,000      PCE-112D1H,000  
PCE-124D1MH,000      PCE-124D1H,000

**Outline Dimensions**

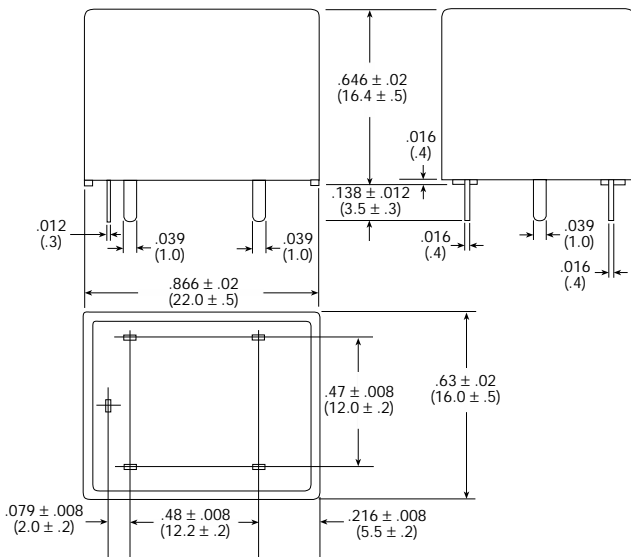

**Wiring Diagram (Bottom View)**

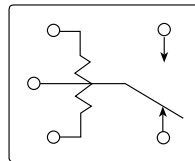

**PC Board Layout (Bottom View)**

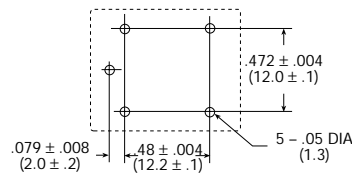

**Socket**

**27E1064** socket is rated 10A @ 300VAC. UL Recognized for US and Canada. Designed to fit same suggested board layout as relay.

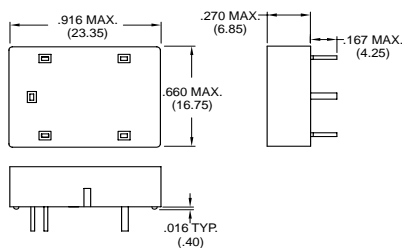



# ORWH series

## 10 Amp Miniature Power PC Board Relay

UL US File No. E82292



Users should thoroughly review the technical data before selecting a product part number. It is recommended that user also seek out the pertinent approvals files of the agencies/laboratories and review them to ensure the product meets the requirements for a given application.

### Features

- Compact relay with 1 Form A and 1 Form C contact arrangements.
- 10 Amp switching capacity.
- Flux-tight or sealed version available.
- Applications include appliance, HVAC, security system, garage opener control, emergency lighting.

### Contact Data @ 20°C

**Arrangements:** 1 Form A (SPST-NO) and 1 Form C (SPDT).

**Material:** AgCdO.

**Max. Switching Rate:** 300 ops./min. (no load).  
20 ops./min. (rated load).

**Expected Mechanical Life:** 10 million operations (no load).

**Expected Electrical Life:** 100,000 operations at 10A @ 250VAC res. (NO).

**Minimum Load:** 100mA @ 5VDC.

**Initial Contact Resistance:** 100 milliohms @ 1A, 6VDC.

### Contact Ratings

**Ratings:** 10A/6A @ 250VAC resistive (NO/NC),  
10A/6A @ 28VDC resistive (NO/NC),  
15A @ 120VAC resistive (NO),  
15A @ 28VDC resistive (NO),  
10A @ 277VAC resistive (NO).

**Max. Switched Voltage:** AC: 277V.  
DC: 30V.

**Max. Switched Current:** 15A.

**Max. Switched Power:** 2,770VA, 360W.

### Initial Dielectric Strength

**Between Open Contacts:** 750VAC 50/60 Hz. (1 minute).

**Between Coil and Contacts:** 1,500VAC 50/60 Hz. (1 minute).

**Surge Voltage Between Coil and Contacts:** 3,000V (1.2 / 50μs).

### Initial Insulation Resistance

**Between Mutually Insulated Elements:** 1,000M ohms min. @ 500VDC.

### Coil Data @ 20°C

**Voltage:** 3 to 48VDC.

**Nominal Power:** 360 mW

**Max. Coil Power:** 130% of nominal.

**Duty Cycle:** Continuous.

### Coil Data @ 20°C

ORWH				
Rated Coil Voltage (VDC)	Nominal Current (mA)	Coil Resistance (ohms) ± 10%	Must Operate Voltage (VDC)	Must Release Voltage (VDC)
3	120.0	25	2.1	0.3
5	71.4	70	3.5	0.5
6	60.0	100	4.2	0.6
9	44.4	225	6.3	0.9
12	40.0	400	8.4	1.2
24	15.0	1,600	16.8	2.4
48	7.5	6,400	33.6	4.8

### Operate Data

**Must Operate Voltage:** 70% of nominal voltage or less.

**Must Release Voltage:** 10% of nominal voltage or more.

**Operate Time:** 10 ms max.

**Release Time:** 5 ms max.

### Environmental Data

**Temperature Range:**

**Operating:** -30°C to +70°C

**Vibration, Mechanical:** 10 to 55 Hz., 1.5mm double amplitude

**Operational:** 10 to 55 Hz., 1.5mm double amplitude.

**Shock, Mechanical:** 1,000m/s<sup>2</sup> (100G approximately).

**Operational:** 100m/s<sup>2</sup> (10G approximately).

**Operating Humidity:** 20 to 85% RH. (Non-condensing).

### Mechanical Data

**Termination:** Printed circuit terminals.

**Enclosure (94V-0 Flammability Ratings):**

**ORWH-SS:** Vented (flux-tight) cover.

**ORWH-SH:** Sealed plastic case. Note: Vent nib should be removed after soldering and cleaning.

**Weight:** 0.33 oz (9.5g) approximately.

**Ordering Information**

<b>Typical Part Number ▶</b>	<b>ORWH</b>	<b>-SS</b>	<b>-1</b>	<b>12</b>	<b>D</b>	<b>M</b>	<b>,N000</b>
<b>1. Basic Series:</b> ORWH = Miniature Power PC board relay.							
<b>2. Enclosure:</b> SS = Vented (flux-tight)* plastic case.      SH = Sealed plastic case							
<b>3. Number of Poles:</b> 1 = 1 pole							
<b>4. Coil Voltage:</b> 03 = 3VDC      06 = 6VDC      12 = 12VDC      48 = 48VDC 05 = 5VDC      09 = 9VDC      24 = 24VDC							
<b>5. Coil Input:</b> D = Standard							
<b>6. Contact Arrangement:</b> Blank = 1 Form C, SPDT      M = 1 Form A, SPST-NO							
<b>7. Option:</b> ,N000= Standard model.      Other Suffix = Custom model.							

\* Not suitable for immersion cleaning

**Our authorized distributors are more likely to maintain the following items in stock for immediate delivery.**

ORWH-SH-112DM,N000	ORWH-SH-109D,N000	ORWH-SS-112DM,N000	ORWH-SS-106D,N000	ORWH-SS-148D,N000
ORWH-SH-124DM,N000	ORWH-SH-112D,N000	ORWH-SS-124DM,N000	ORWH-SS-109D,N000	
ORWH-SH-105D,N000	ORWH-SH-124D,N000	ORWH-SS-148DM,N000	ORWH-SS-112D,N000	
ORWH-SH-106D,N000	ORWH-SH-148D,N000	ORWH-SS-105D,N000	ORWH-SS-124D,N000	

**Outline Dimensions**

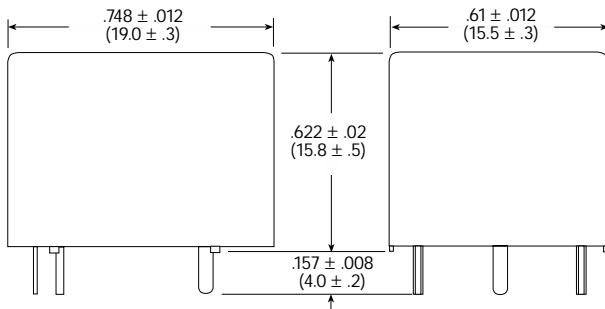

TERMINAL DIMENSIONS:  
COIL: 0.024 (0.6) DIA.  
LOAD: 0.12 x 0.35 (0.3 x 0.9)

**Note:** Only necessary terminals are present on 1 Form A models.

**Wiring Diagram (Bottom View)**

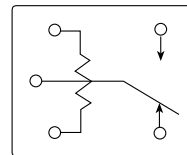

**PC Board Layout (Bottom View)**

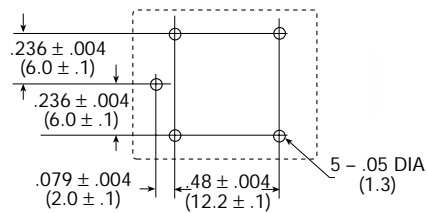

**Socket**

**27E1064** socket is rated 10A @ 300VAC. UL Recognized for US and Canada. Designed to fit same suggested board layout as relay.

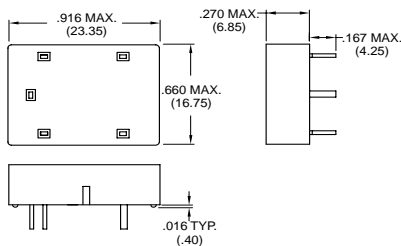

# T7C series

## 5 - 12 Amp Miniature Power PC Board Relay

File E22575

File LR48471

Users should thoroughly review the technical data before selecting a product part number. It is recommended that user also seek out the pertinent approvals files of the agencies/laboratories and review them to ensure the product meets the requirements for a given application.



### Features

- Up to 12 amp switching capacity.
- UL Class F (155°C) coil insulation system.
- 1 Form A and 1 Form C contact arrangements.
- Ideal for domestic appliances, HVAC and security.
- Resists high temperature and various chemical solutions.

### Contact Data @ 20°C

**Arrangements:** 1 Form A (SPST-NO) and 1 Form C (SPDT).

**Material:** Silver-cadmium oxide or silver.

**Max. Switching Rate:** 300 ops./min. (no load).  
30 ops./min. (rated load).

**Expected Mechanical Life:** 10 million operations.

**Expected Electrical Life:** 100,000 operations.

**Minimum Load:** 10mA @ 5VDC

**Initial Contact Resistance:** Ag: 100 milliohms max. @ 100mA, 6VDC.  
AgCdO: 100 milliohms max. @ 1A, 6VDC.

**Silver Cadmium Oxide Contact Ratings @ 20°C with relay properly vented. Remove vent nib after soldering and cleaning.**

Contact Arrang.	UL/CSA Ratings	Type	Operations
1 & 5	1/3HP NO @ 120VAC	Motor	6,000**
	TV-2 NO @ 120VAC	Tungsten	25,000**
	5.4LRA/0.9FLA NO @ 240VAC	Motor	30,000***
	10LRA/1.5FLA @ 120VAC	Motor	30,000***
	12A NO @ 120VAC	Resistive/GP	100,000*
	34.8LRA/6FLA NO @ 120VAC	Motor	100,000**
	10A/5A @ 240VAC	Resistive/GP	100,000**
	10A/5A @ 28VDC	Resistive	100,000**
	240VA, 240VAC	Pilot Duty	100,000**
	4LRA/4FLA NO @ 120VAC	Motor	100,000****
	4LRA/2FLA NC @ 120VAC	Motor	100,000****
	6LRA/6FLA NO @ 120VAC	Motor	100,000***
	7A @ 277VAC	Resistive/GP	100,000
	10LRA/2.5FLA NO @ 277VAC	Motor	100,000

Consult factory for other ratings.

\*Denotes test at 60°C ambient temperature.

\*\*Denotes test at 70°C ambient temperature.

\*\*\*Denotes test at 85°C ambient temperature.

\*\*\*\*Denotes test at 105°C ambient temperature.

**Silver Contact Ratings @ 20°C with relay properly vented. Remove vent nib after soldering and cleaning.**

Contact Arrang.	Ratings	Type	Operations
1 & 5	5A @ 120VAC	Resistive	6,000
	5A @ 28VDC	Resistive	6,000

### Initial Dielectric Strength

**Between Open Contacts:** 750VAC 50/60 Hz. (1 minute).

**Between Coil and Contacts:** 1,500VAC 50/60 Hz. (1 minute).

### Initial Insulation Resistance

**Between Mutually Insulated Elements:** 10<sup>8</sup> ohms min. @ 500VDC.

### Coil Data @ 20°C

**Voltage:** 3 to 48VDC.

**Nominal Power:** 360 milliwatts.

510 milliwatts for 48VDC coil.

**Coil Temperature Rise:** 35°C max, at rated coil voltage.

**Max. Coil Voltage:** 130% of nominal.

**Duty Cycle:** Continuous.

### Coil Data @ 20°C

Rated Coil Voltage (VDC)	Coil Resistance (Ohms) +10%	Must Operate Voltage (VDC)	Must Release Voltage (VDC)
3	25	2.25	0.15
5	70	3.50	0.25
6	100	4.50	0.30
9	225	6.75	0.45
12	400	9.00	0.60
24	1,600	18.00	1.20
48	4,500	36.00	2.40

### Operate Data @ 20°C

**Operate Time:** 10 ms (excluding bounce).

**Release Time:** 5 ms (excluding bounce).

### Environmental Data

**Temperature Range:**

**Storage:** -40°C to +130°C.

**Operating:** -40°C to +85°C.

**Vibration, Mechanical:** 10 to 55 Hz., 1.5mm double amplitude

**Operational:** 10 to 55 Hz., 1.5mm double amplitude.

**Shock, Mechanical:** 100g min.

**Operational:** 10g min.

**Operating Humidity:** 45 to 85% RH.

### Mechanical Data

**Termination:** Printed circuit terminals.

**Enclosure (94V-0 Flammability Ratings):**

**T7CS:** Immersion cleanable with knock-off nib.

**T7CV:** Vented, flux-tight, plastic cover with knock-off nib.

**Weight:** 0.42 oz. (12g).

Figure 1 - Coil Temperature Rise

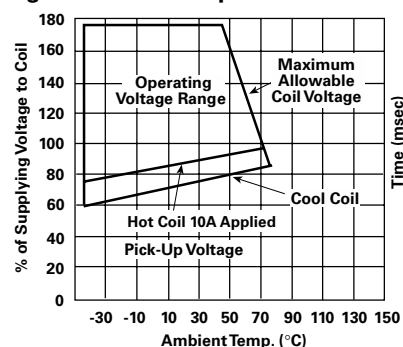

Operate Time

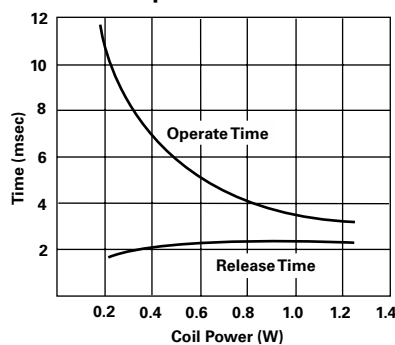

Life Expectancy

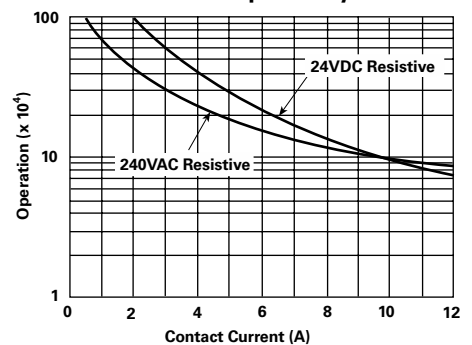

**Note:** Graphical data should not be used as a substitute for specific application verification. To be used for estimates only. Graphical data applicable to model with silver cadmium oxide contacts.

**Ordering Information**

<b>Typical Part Number ▶</b>				<b>T7C</b>	<b>V</b>	<b>5</b>	<b>D</b>	<b>-24</b>
<b>1. Basic Series:</b> T7C = Miniature power relay.								
<b>2. Enclosure:</b> V = Vented (Flux-tight)*      S = Immersion cleanable case with knock-off nib.								
<b>3. Contact Arrangement:</b> 1 = 1 Form A (SPST-NO)      5 = 1 Form C (SPDT)								
<b>4. Coil Input:</b> D = DC Voltage								
<b>5. Contact Material:</b> Leave Blank = Silver Cadmium Oxide (12A Max. Rating)      2 = Silver (5A Max. Rating)								
<b>6. Coil Voltage:</b>								
03 = 3VDC			05 = 5VDC		06 = 6VDC		09 = 9VDC	
12 = 12VDC			18 = 18VDC		24 = 24VDC		48 = 48VDC	

\* Not suitable for immersion cleaning processes.

**Our authorized distributors are more likely to maintain the following items in stock for immediate delivery.**

T7CV5D-05	T7CV5D-12	T7CS5D-05	T7CS5D-12
T7CV5D-06	T7CV5D-24	T7CS5D-06	T7CS5D-24

**Outline Dimensions**

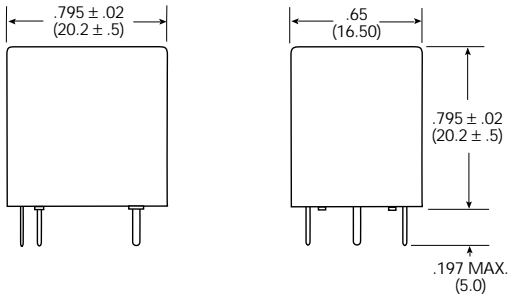

**Movable Contact Terminal:**  
.012 x .039 (0.3 x 1.0)  
**Stationary Contact Terminals:**  
.012 x .039 (0.3 x 1.0)  
**Coil Terminals:**  
.022 x .022 (.56 x .56)

**Wiring Diagrams (Bottom Views)**

**1 Form A**

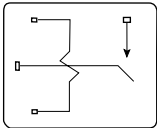

**1 Form C**

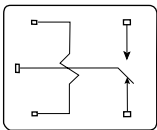

**Suggested PC Board Layouts (Bottom Views)**

**1 Form A**

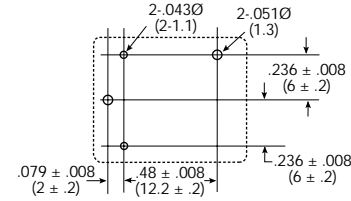

**1 Form C**

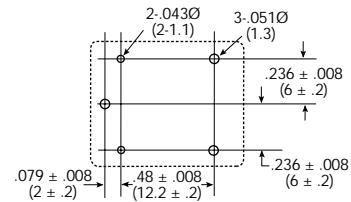

**Socket**

**27E1064** socket is rated 10A @ 300VAC. UL Recognized for US and Canada. Designed to fit same suggested board layout as relay.

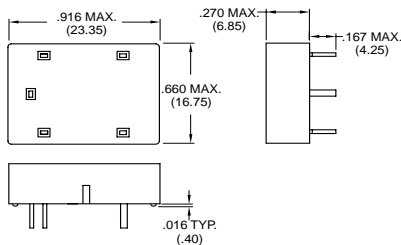

**Hold-Down Spring**

**20C430** spring is designed to secure T7C relay in 27E1064 socket.

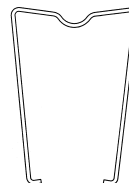

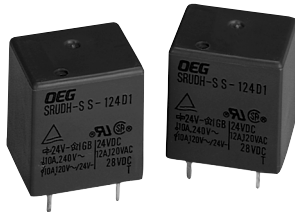

# SRUDH series

## 12 Amp Miniature Power PC Board Relay

Appliances, HVAC, Office Machines

UL File No. E82292

CSA File No. LR48471

TUV File No. R60271

Users should thoroughly review the technical data before selecting a product part number. It is recommended that user also seek out the pertinent approvals files of the agencies/laboratories and review them to ensure the product meets the requirements for a given application.

### Features

- Small package, 12 Amp switching capacity.
- 1 Form A and 1 Form C contact arrangements.
- Immersion cleanable, sealed version available.
- Applications include appliance, HVAC, security system, garage opener control, emergency lighting.

### Contact Data @ 20°C

**Arrangements:** 1 Form A (SPST-NO) and 1 Form C (SPDT).

**Material:** Ag Alloy.

**Max. Switching Rate:** 300 ops./min. (no load).  
30 ops./min. (rated load).

**Expected Mechanical Life:** 10 million operations (no load).

**Expected Electrical Life:** 100,000 operations (rated load).

**Minimum Load:** 100mA @ 5VDC.

**Initial Contact Resistance:** 100 milliohms @ 1A, 6VDC.

### Contact Ratings

**Ratings:** 12A @ 120VAC resistive,  
10A @ 240VAC resistive,  
10A @ 28VDC resistive.

4A @ 120VAC inductive (cosφ= 0.4),  
4A @ 28VDC inductive (L/R=7msec)

**Max. Switched Voltage:** AC: 240V.  
DC: 28V.

**Max. Switched Current:** 12A.

**Max. Switched Power:** 2,400VA, 300W.

### Initial Dielectric Strength

**Between Open Contacts:** 750VAC 50/60 Hz. (1 minute).

**Between Coil and Contacts:** 1,500VAC 50/60 Hz. (1 minute).

**Surge Voltage Between Coil and Contacts:** 3,000V (1.2 / 50μs).

### Initial Insulation Resistance

**Between Mutually Insulated Elements:** 1,000M ohms min. @ 500VDCM.

### Coil Data

**Voltage:** 6 to 48VDC.

**Nominal Power:** 360 mW except 48VDC coil (510mW)

**Coil Temperature Rise:** 35°C max., at rated coil voltage.

**Max. Coil Power:** 130% of nominal.

**Duty Cycle:** Continuous.

### Coil Data @ 20°C

SRUDH				
Rated Coil Voltage (VDC)	Nominal Current (mA)	Coil Resistance (ohms) ± 10%	Must Operate Voltage (VDC)	Must Release Voltage (VDC)
6	60	100	4.50	0.60
9	40	225	6.75	0.90
12	30	400	9.00	1.20
24	15	1,600	18.00	2.40
48	10	4,500	36.00	4.80

### Operate Data

**Must Operate Voltage:** 75% of nominal voltage or less.

**Must Release Voltage:** 10% of nominal voltage or more.

**Operate Time:** 15 ms max.

**Release Time:** 5 ms max.

### Environmental Data

**Temperature Range:**

**Operating:** -30°C to +60°C

**Vibration, Mechanical:** 10 to 55 Hz., 1.5mm double amplitude

**Operational:** 10 to 55 Hz., 1.5mm double amplitude.

**Shock, Mechanical:** 1,000m/s<sup>2</sup> (100G approximately).

**Operational:** 100m/s<sup>2</sup> (10G approximately).

**Operating Humidity:** 20 to 85% RH. (Non-condensing).

### Mechanical Data

**Termination:** Printed circuit terminals.

**Enclosure (94V-0 Flammability Ratings):**

**SRUDH-SS:** Vented (Flux-tight) plastic cover

**SRUDH-SH:** Sealed plastic case

**Weight:** 0.42 oz (12g) approximately.

### Reference Data

#### Coil Temperature Rise

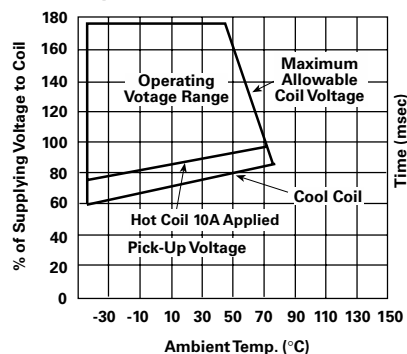

#### Operate Time

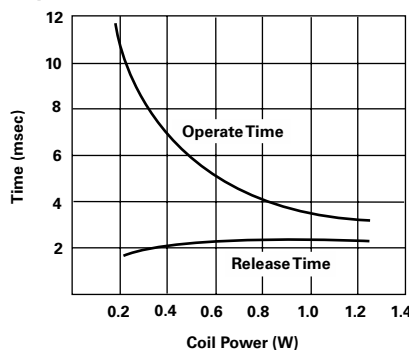

#### Life Expectancy

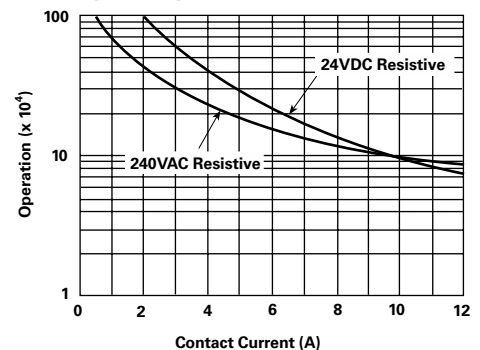

**Note:** Rise data is based on the max. allowable temp. for E type insulation coil (115°C).

**Ordering Information**

<b>Typical Part Number ▶</b>	<b>SRUDH</b>	<b>-SS</b>	<b>-1</b>	<b>12</b>	<b>D</b>	<b>M</b>	<b>1</b>	<b>,000</b>
<p><b>1. Basic Series:</b> SRUDH = Miniature Power PC board relay.</p> <p><b>2. Enclosure:</b> SS = Vent (Flux-tight)* plastic cover. SH = Sealed, plastic case.</p> <p><b>3. Termination:</b> 1 = 1 pole</p> <p><b>4. Coil Voltage:</b> 06 = 6VDC      12 = 12VDC      48 = 48VDC 09 = 9VDC      24 = 24VDC</p> <p><b>5. Coil Input:</b> D = Standard</p> <p><b>6. Contact Arrangement:</b> Blank = 1 Form C, SPDT      M = 1 Form A, SPST-NO</p> <p><b>7. Contact Material:</b> 1 = AgCdO</p> <p><b>8. Suffix:</b> ,000 = Standard model      Other Suffix = Custom model</p>								

\* Not suitable for immersion cleaning processes.

**Our authorized distributors are more likely to maintain the following items in stock for immediate delivery.**

SRUDH-SH-112D1,000      SRUDH-SH-112DM1,000  
SRUDH-SH-124D1,000      SRUDH-SH-124DM1,000

**Outline Dimensions**

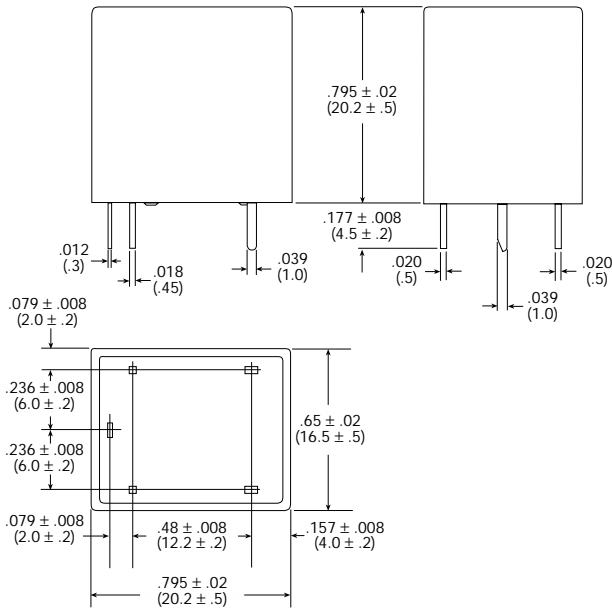

**Wiring Diagram (Bottom View)**

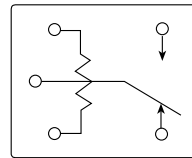

**PC Board Layout (Bottom View)**

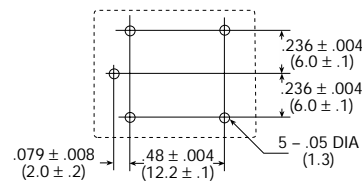

**Socket**

**27E1064** socket is rated 10A @ 300VAC. UL Recognized for US and Canada. Designed to fit same suggested board layout as relay.

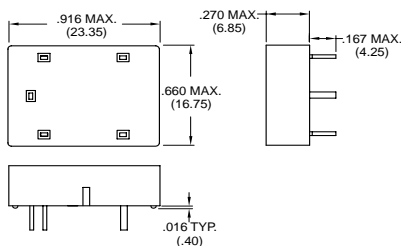

**Hold-Down Spring**

**20C430** spring is designed to secure SRUDH relay in 27E1064 socket.

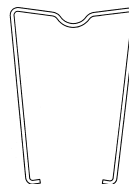



# SRUHH series

## 15 Amp Miniature Power PC Board Relay

 UL File No. E82292

 TUV File No. R60271

Users should thoroughly review the technical data before selecting a product part number. It is recommended that user also seek out the pertinent approvals files of the agencies/laboratories and review them to ensure the product meets the requirements for a given application.

### Features

- 15 Amp switching capacity.
- 1 Form A and 1 Form C contact arrangements.
- Immersion cleanable, sealed version available.
- Applications include appliance, HVAC, security system, garage opener control, emergency lighting.

### Contact Data @ 20°C

**Arrangements:** 1 Form A (SPST-NO) and 1 Form C (SPDT).

**Material:** Silver cadmium oxide.

**Max. Switching Rate:** 300 ops./min. (no load).  
20 ops./min. (rated load).

**Expected Mechanical Life:** 10 million operations (no load).

**Expected Electrical Life:** 100,000 operations (rated load, relay vented).

**Minimum Load:** 100mA @ 5VDC.

**Initial Contact Resistance:** 100 milliohms @ 1A, 6VDC.

### Contact Ratings

**Ratings:** 15A @ 120VAC resistive,  
10A @ 240VAC resistive,  
10A @ 28VDC resistive.

**Max. Switched Voltage:** AC: 240V.  
DC: 28V.

**Max. Switched Current:** 15A.

**Max. Switched Power:** 2,400VA, 300W.

**Note:** Sealed relays should be vented after soldering and cleaning in order to achieve listed ratings.

### Initial Dielectric Strength

**Between Open Contacts:** 750VAC 50/60 Hz. (1 minute).

**Between Coil and Contacts:** 1,500VAC 50/60 Hz. (1 minute).

**Surge Voltage Between Coil and Contacts:** 3,000V (1.2 / 50μs).

### Initial Insulation Resistance

**Between Mutually Insulated Elements:** 100M ohms min. @ 500VDC.

### Coil Data

**Voltage:** 3 to 48VDC.

**Nominal Power:** 360 mW except 48VDC coil (510mW).

**Coil Temperature Rise:** 60°C max., at rated coil voltage.

**Max. Coil Power:** 130% of nominal.

**Duty Cycle:** Continuous.

### Coil Data @ 20°C

SRUHH				
Rated Coil Voltage (VDC)	Nominal Current (mA)	Coil Resistance (ohms) ± 10%	Must Operate Voltage (VDC)	Must Release Voltage (VDC)
3	120	25	2.25	0.30
6	60	100	4.50	0.60
9	40	225	6.75	0.90
12	30	400	9.00	1.20
24	15	1,600	18.00	2.40
48	10	4,500	36.00	4.80

### Operate Data

**Must Operate Voltage:** 75% of nominal voltage or less.

**Must Release Voltage:** 10% of nominal voltage or more.

**Operate Time:** 15 ms max.

**Release Time:** 5 ms max.

### Environmental Data

**Temperature Range:**

**Operating:** -30°C to +60°C

**Vibration, Mechanical:** 10 to 55 Hz., 1.5mm double amplitude

**Operational:** 10 to 55 Hz., 1.5mm double amplitude.

**Shock, Mechanical:** 1,000m/s<sup>2</sup> (100G approximately).

**Operational:** 100m/s<sup>2</sup> (10G approximately).

**Operating Humidity:** 20 to 85% RH. (Non-condensing).

### Mechanical Data

**Termination:** Printed circuit terminals.

**Enclosure (94V-0 Flammability Ratings):**

**SRUHH-SS:** Vented (Flux-tight) plastic cover

**SRUHH-SH:** Sealed plastic case

**Weight:** 0.42 oz (12g) approximately.

**Ordering Information**

Typical Part Number ▶

**SRUUH -SS -1 12 D 1 M ,000**

**1. Basic Series:**  
SRUUH = Miniature Power PC board relay.

**2. Enclosure:**  
SS = Vent (Flux-tight)\* plastic cover. SH = Sealed, plastic case.

**3. Termination:**  
1 = 1 pole

**4. Coil Voltage:**  
03 = 3VDC      09 = 9VDC      24 = 24VDC  
06 = 6VDC      12 = 12VDC      48 = 48VDC

**5. Coil Input:**  
D = Standard

**6. Contact Material:**  
1 = Silver Cadmium Oxide

**7. Contact Arrangement:**  
Leave Blank = 1 Form C, SPDT      M = 1 Form A, SPST-NO

**8. Option:**  
,000= Standard model.      Other Suffix = Custom model.

\* Not suitable for immersion cleaning processes.

**Our authorized distributors are more likely to maintain the following items in stock for immediate delivery.**

SRUUH-SH112D1M,000      SRUUH-SH112D1,000  
SRUUH-SH124D1M,000      SRUUH-SH124D1,000

**Outline Dimensions**

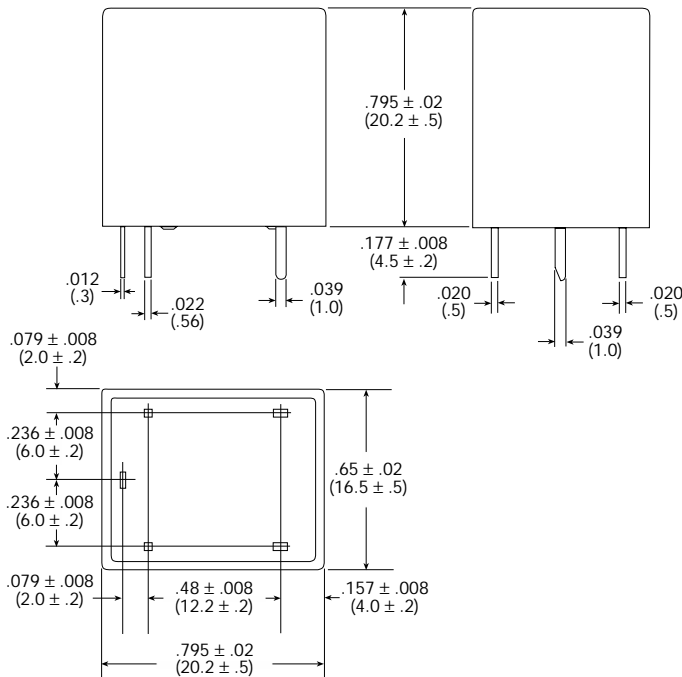

**Wiring Diagram (Bottom View)**

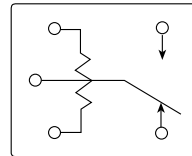

**PC Board Layout (Bottom View)**

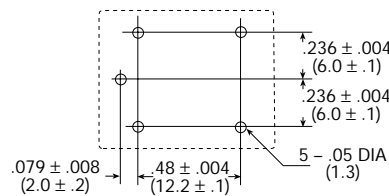

**Note:** Only necessary terminals are present on 1 Form A (SPST-NO) models.

**Socket**

**27E1064** socket is rated 10A @ 300VAC. UL Recognized for US and Canada. Designed to fit same suggested board layout as relay.

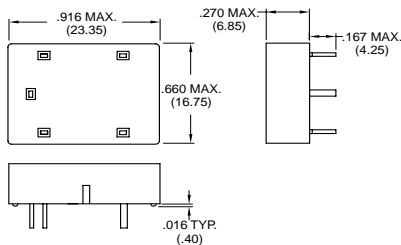

**Hold-Down Spring**

**20C430** spring is designed to secure SRUUH relay in 27E1064 socket.

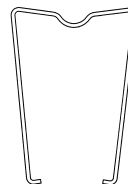



# RT series (DC Coil)

## 16 Amp PC Board Miniature Relay

UL File E22575  
 SF File LR15734  
 NR 6106

Users should thoroughly review the technical data before selecting a product part number. It is recommended that users also seek out the pertinent approvals files of the agencies/laboratories and review them to ensure the product meets the requirements for a given application.

### Features

- SPST through DPDT contact arrangements.
- Immersion cleanable and flux tight versions available.
- VDE 10mm spacing, 5kV dielectric, coil to contacts.
- UL Class F (155°C) coil insulation system.
- Conforms to UL 508, 1873, 353 and 1950.
- Low profile: 15.7mm height.
- Sensitive coil; 400mW.
- Withstand surge voltage of 10,000V.
- Potter & Brumfield or Schrack brand.

### Contact Data

**Arrangements:** 1 Form A (SPST-NO) Wiring Diagram Code 1, 2, 3.  
 2 Form A (DPST-NO) Wiring Diagram Code 5.  
 1 Form C (SPDT) Wiring Diagram Code 1, 2, 3.  
 2 Form C (DPDT) Wiring Diagram Code 5.

**Material:** Silver-nickel 90/10.

**Minimum Load:** 12V/100mA.

**Expected Mechanical Life:** 10 million operations.

**Initial Contact Resistance:** 100 milliohms max @ 1A 12VDC.

**Designed to meet UL/CSA/VDE ratings with relay properly vented. Remove vent nib after soldering and cleaning.**

### UL/CSA/VDE Ratings @ 25°C

Code	NO/NC Load	Type	Operations
1	10A/10A @ 277VAC	Resistive/GP	100K
	10A/10A @ 30VDC	Resistive	100K
	12A/12A @ 250VAC	Resistive/GP	30K
	12A/12A @ 30VDC	Resistive	30K
	3/4 HP @ 480VAC*	Motor	6K
	1/2 HP @ 240VAC*	Motor	6K
	1/3 HP @ 120VAC*	Motor	6K
	48 LRA/10 FLA @ 240VAC*	Motor	30K
	TV-3 @ 120VAC*	Tungsten	25K
	A300, 720VA @ 240VAC*	Pilot Duty	30K
3	16A/16A @ 250VAC	Resistive/GP	50K
	20A/20A @ 277VAC	Resistive/GP	30K
	20A/20A @ 24VDC	Resistive	30K
	16A/16A @ 30VDC	Resistive	30K
	1 HP @ 480VAC*	Motor	6K
	1 HP @ 240VAC*	Motor	6K
	1/2 HP @ 120VAC*	Motor	6K
	60 LRA/10 FLA @ 250VAC*	Motor	30K
	TV-5 @ 120VAC*	Tungsten	25K
	A300, 720VA @ 240VAC*	Pilot Duty	30K
B300, 360VA @ 240VAC**	Pilot Duty	30K	
5	8A/8A @ 277VAC	Resistive/GP	100K
	8A/8A @ 30VDC	Resistive	100K
	10A/10A @ 250VAC	Resistive/GP	30K
	10A/10A @ 30VDC	Resistive	30K
	1/2 HP @ 240VAC*	Motor	6K
	1/4 HP @ 120VAC*	Motor	6K
	34.8 LRA/6 FLA @ 120VAC*	Motor	30K
	17.4 LRA/5 FLA @ 240VAC*	Motor	30K
	B300, 360VA @ 240VAC*	Pilot Duty	30K
	TV-3 @ 120VAC*	Tungsten	25K

\* Form A only  
 \*\* Form B only

### Initial Dielectric Strength

**Between Open Contacts:** >1,000VAC (1 minute).  
**Between Poles (code 5):** >2,500VAC (1 minute).  
**Between Coil and Contacts:** >5,000VAC (1 minute).  
**Surge Voltage (DC):** >10,000VAC x (1.2 x 50 µsec).

### Coil Data @ 25°C

**Voltage:** 5 to 110VDC.

**Nominal Power @ 25°C:** 400mW.

**Duty Cycle:** Continuous.

**Initial Insulation Resistance:** 10,000 megohms, min., at 25°C, 500VDC and 50% rel. humidity.

**Coil Construction:** UL Class F (155°C).

### Coil Data @ 25°C

Nominal Voltage VDC	DC Resistance in Ohms ±10%	Must Operate Voltage VDC	Nominal Coil Current (mA) – 50/60Hz.
005	62	3.5	80
006	90	4.2	66.7
009	202	6.3	44.4
012	360	8.4	33.3
018	810	12.6	22.2
024	1,440	16.8	16.7
048	5,760	33.6	8.3
060	9,000	42.0	8.0
110	30,250	77.0	4.3

### Max. Ambient Temp. vs. Coil Voltage

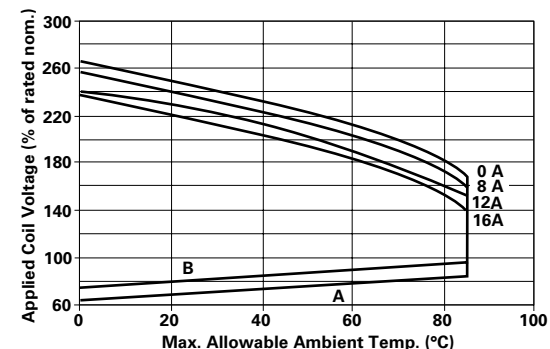

A: Coil temperature = Ambient temperature.  
 B: 110% of nominal coil voltage at rated contact load.

### Operate Data @ 25°C

**Must Operate Voltage(DC):** 70% of nominal.

**Must Release Voltage(DC):** 10% of nominal.

**Operate Time (Excluding Bounce):**  
 7 ms, typ., 15ms max. at nom. voltage.

**Release Time (Excluding Bounce):**  
 3 ms, typ., 6ms max. at nom. voltage.

### Environmental Data

**Temperature Range:**

**Storage:** -40°C to +105°C.

**Operating:** -40°C to +85°C at rated current.

**Vibration, Operational**

N.O.: 0.065" (1.65mm) max. excursions from 10 - 55 Hz:

N.C.: 0.032" (0.82mm) max. excursions from 10 - 55 Hz:

with no contact opening >10µs.

### Mechanical Data

**Termination:** Printed circuit terminals.

**Enclosures:** RT 1, 2, 3, 4: Flux-tight, top vented, plastic case.

RT B, C, D, E: Immersion cleanable, plastic case.

**Weight:** 0.35 oz. (10g) approximately.





# RT series (AC Coil)

## 16 Amp Miniature Printed Circuit Board Relay

UL File E214025

NR 6106

Users should thoroughly review the technical data before selecting a product part number. It is recommended that users also seek out the pertinent approvals files of the agencies/laboratories and review them to ensure the product meets the requirements for a given application.

### Features

- SPST through DPDT contact arrangements.
- Immersion cleanable and flux tight versions available.
- Meets VDE 10mm spacing, 5kV dielectric, coil to contacts.
- Conforms to UL 508, 1873 and 353.
- UL Class F (155°C) coil construction
- Schrack brand

### Contact Data

**Arrangements:** 1 Form A (SPST-NO) Wiring Diagram Code 1, 2, 3.  
2 Form A (DPST-NO) Wiring Diagram Code 5.  
1 Form C (SPDT) Wiring Diagram Code 1, 2, 3.  
2 Form C (DPDT) Wiring Diagram Code 5.

**Material:** Silver-nickel 90/10.

**Minimum Load:** 12V/100mA.

**Expected Mechanical Life:** 10 million operations.

**Designed to meet UL/CSA/VDE ratings with relay properly vented. Remove vent nib after soldering and cleaning.**

### UL/CSA Ratings @ 25°C:

Code	NO/NC Load	Type	Operations
1	12A NO @ 240VAC	GP	30K
	10A/5A @ 240VAC	Resistive/GP	100K
	8A @ 28VDC	Resistive	30K
	1 HP @ 240VAC*	Motor	6K
	1/2 HP @ 120VAC*	Motor	6K
	8A @ 28VDC* B300	Resistive Pilot Duty	30K 6K
3	16A/8A @ 240VAC	GP	6K
	8A @ 28VDC	Resistive	30K
	1/2 HP @ 120VAC*	Motor	6K
	1HP @ 240VAC*	Motor	6K
	48 LRA, 8 FLA @ 240VAC	Motor	30K
	B300	Pilot Duty	6K
5	8A @ 240VAC	Resistive	30K
	8A @ 28VDC	Resistive/GP	30K
	1/2 HP @ 240VAC	Motor	6K
	1/4 HP @ 120VAC	Motor	6K
	B300	Pilot Duty	6K

\* Form A only

### VDE Ratings @ 25°C:

Code	NO/NC Load	Type	Operations
1	12A @ 250VAC	Resistive	30K
	12A @ 250VAC	Resistive	100K
3	16A @ 250VAC	Resistive	10K
	16A @ 250VAC	Resistive	50K
5	8A @ 250VAC	Resistive	30K
	8A @ 250VAC	Resistive	50K

### Initial Dielectric Strength

**Between Open Contacts:** >1,000VAC (1 minute).

**Between Poles (code 5):** >2,500VAC (1 minute).

**Between Coil and Contacts:** >5,000VAC (1 minute).

**Creepage/Clearance, Coil to Contact:** 10/10mm.

### Coil Data @ 20°C

**Voltage:** 24, 115, 230VAC (consult factory for availability of other voltages).

**Nominal Power @ 25°C:** .75VA.

**Duty Cycle:** Continuous.

**Initial Insulation Resistance:** 10,000 megohms, min., at 20°C, 500VDC and 50% rel. humidity.

**Coil Construction:** UL Class F (155°C).

### Coil Data

Nominal Voltage VAC	DC Resistance in Ohms ±10%	Must Operate Voltage VAC	Drop-out Voltage VAC	Nominal Coil Current (mA)-50Hz.	Nominal Coil Current (mA)-60Hz.
24	350	18.0	3.6	31.6	24.3
115	8,100	86.3	17.3	6.6	5.1
230	32,500	172.5	34.5	3.3	2.3

### Max. Ambient Temp. vs. Coil Voltage

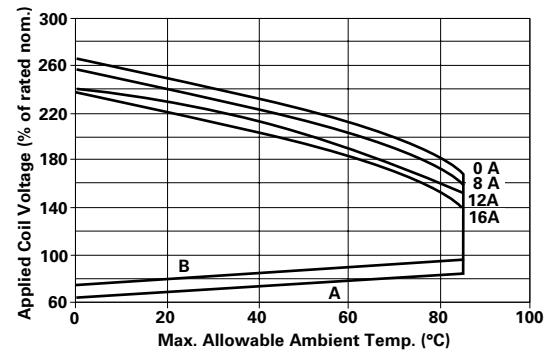

A: Coil temperature = Ambient temperature.

B: 110% of nominal coil voltage at rated contact load.

### Operate Data

**Must Operate Voltage:** See coil data.

**Operate Time (Excluding Bounce):** 8 ms, typ., at nom. voltage.

**Release Time (Excluding Bounce):** 11 ms, typ., at nom. voltage.

### Environmental Data

**Temperature Range:**

**Storage:** -40°C to +105°C.

**Operating:** -40°C to +70°C at rated current.

**Vibration:** 30 - 150 Hz:

at 20g with no contact opening >10µs on the N.O. contact;  
at 5g with no contact opening >10µs on the N.C. contact.

### Mechanical Data

**Termination:** Printed circuit terminals.

**Enclosures:** RT 1, 2, 3, 4: Flux-tight, top vented, plastic case.

RT B, C, D, E: Immersion cleanable, plastic case.

**Weight:** 0.42 oz. (12g) approximately.

**Ordering Information (AC Coil Model)**

Typical Part Number ▶

**RT**

**D**

**1**

**4**

**524**

**1. Basic Series:**

RT = Miniature, printed circuit board relay.

**2. Enclosure:**

1 = 1 pole 12A, Pinning 3.5mm, flux-tight (Code 1).      B = 1 pole 12A, Pinning 3.5mm, sealed (Code 1).  
 2 = 1 pole 12A, Pinning 5mm, flux-tight (Code 2).      C = 1 pole 12A, Pinning 5mm, sealed (Code 2).  
 3 = 1 pole 16A, Pinning 5mm, flux-tight (Code 3).      D = 1 pole 16A, Pinning 5mm, sealed (Code 3).  
 4 = 2 pole 8A, Pinning 5mm, flux-tight (Code 5).      E = 2 pole 8A, Pinning 5mm, sealed (Code 5).

**3. Contact Arrangement:**

1 = 1 Form C (SPDT) (Requires wiring diagram codes 1, 2 or 3.)  
 2 = 2 Form C (DPDT) (Requires wiring diagram code 5.)  
 3 = 1 Form A (SPST-NO) (Requires wiring diagram codes 1, 2 or 3.)  
 4 = 2 Form A (DPST-NO) (Requires wiring diagram code 5.)

**4. Contact Material:**

4 = Silver-nickel 90/10.

**5. Coil Voltage:**

524 = 24VAC      615 = 115VAC      730 = 230VAC

**Note:** All AC coil model RT part numbers are Schrack brand, are orange in color and have UL Class F (155°C) coil construction.

**Our authorized distributors are more likely to stock the following items for immediate delivery.**

RTB14524      RTD14524      RTE24524  
 RTB14615      RTD14615      RTE24615  
 RTB14730      RTD14730      RTE24730

**Outline Dimensions**

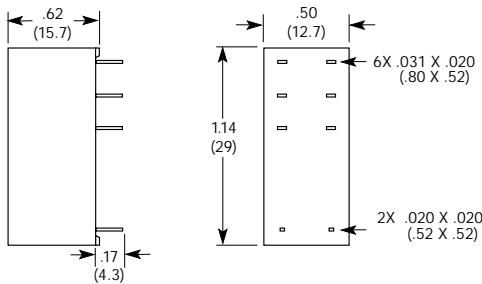

**Breaking Capacity**

**1 Pole**

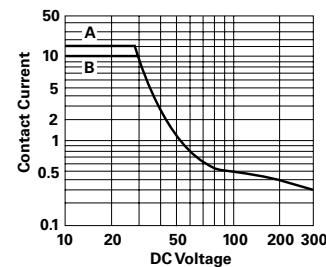

**2 Pole**

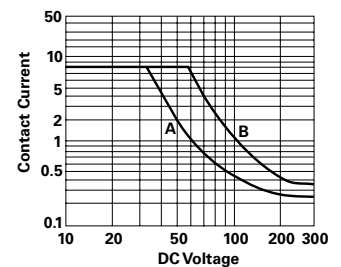

A: 16A Version.  
B: 12A Version.

A: 1 Contact.  
B: 2 Contacts in series.

**PC Board Layouts (Bottom View)**

**1 Pole 12A  
3.5mm**

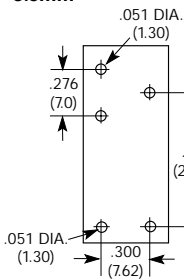

**Code 1**

**1 Pole 12A  
5mm**

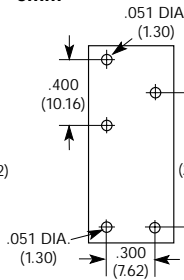

**Code 2**

**1 Pole 16A  
2 Pole 8A  
5mm**

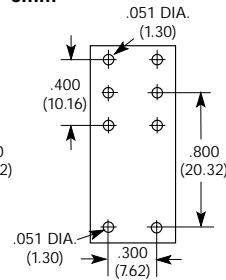

**Code 3 & 5**

**Notes:** 1. On single throw models, only necessary terminals are present.  
 2. With the recommended PCB hole sizes, a grid with a pattern from 0.0984 to 0.1 in (2.5 - 2.54 mm) can be used.

**Contact Life for Resistive AC Load (Typical)**

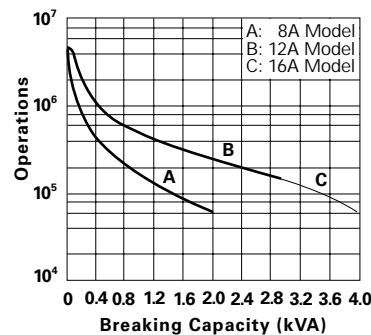

**Note:** Data from 250VAC @ 70°C.

**Wiring Diagrams (Bottom View)**

**1 Pole 12A**

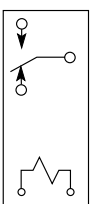

**Codes 1 & 2**

**1 Pole 16A**

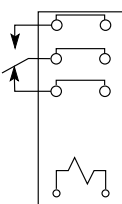

**Code 3**

**2 Pole 8A**

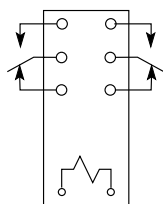

**Code 5**

**Note:** On single throw models, only necessary terminals are present.



RT78625 with RPMU0730



RP78601



RT16016

# RT series Sockets and Accessories

- File E135149
- File LR14385
- NR 5318

## Sockets for RT Series Relays

**RT78624<sup>1</sup>**  
10A, 300VAC  
3.5mm Pinning

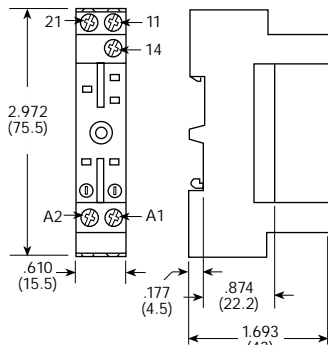

Hold-Down Spring RT16016

**RT78625<sup>1,2</sup>**  
1 Pole 10A, 250VAC  
2 Pole 2x 10A, 250VAC  
5mm Pinning

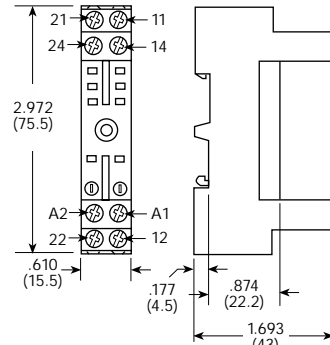

Hold-Down Spring RT16016

**RT78626<sup>1,2</sup>**  
1 Pole 12A, 300VAC  
2 Pole 2x 12A, 300VAC  
5mm Pinning

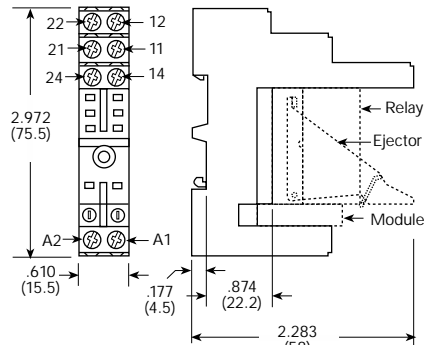

Ejector/Hold-Down Spring RT16016<sup>3</sup>

**RP78601<sup>1</sup>**  
10A, 250VAC  
3.5mm Pinning

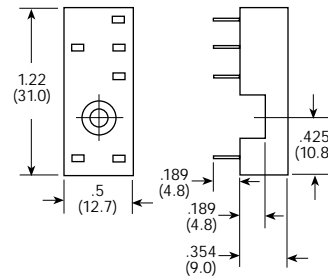

Hold-Down Spring RP16041

PC Board Layout  
(Bottom View)

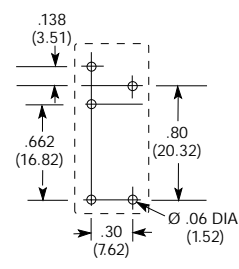

**RP78602<sup>1</sup>**  
1 Pole 10A, 250VAC  
2 Pole 2x 10A, 250VAC  
5mm Pinning

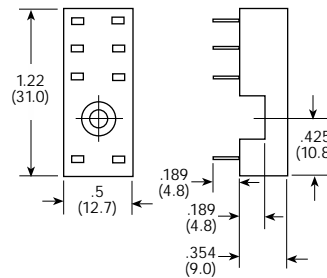

Hold-Down Spring RP16041

PC Board Layout  
(Bottom View)

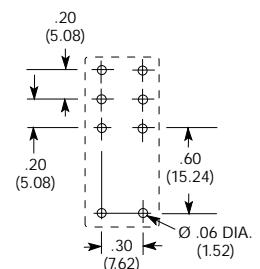

## Socket and Accessory Selection Table

Stock items are boldfaced.

Socket	Socket Termination	Hold-Down Spring
<b>RT78624<sup>1,2</sup></b>	DIN Screw Terminal Socket	<b>RT16016</b>
<b>RT78625<sup>1,2</sup></b>	DIN Screw Terminal Socket	<b>RT16016</b>
RT78626 <sup>1</sup>	DIN Screw Terminal Socket	<b>RT16016</b>
<b>RP78601<sup>1</sup></b>	PCB Terminal Socket	RY16041
<b>RP78602<sup>1</sup></b>	PCB Terminal Socket	RY16041
RPMT00A0	Protection Diode Module 1N4007 <sup>4</sup>	-
RPMU0548	RC Network Module 24-48VAC	-
RPMU0730	RC Network Module 110-230VAC	-
RPML0024	LED Module 12-24VDC <sup>4</sup>	-
RPML0524	LED Module 12-48VAC/VDC	-
RPML0110	LED Module 110VDC <sup>4</sup>	-
RPML0730	LED Module 110-230VAC	-

**\* Note**

1. Not suitable for bistable relay with two coils.
2. For a 16A 1 pole relay the following jumpers have to be connected; 11 to 21, 12 to 22 and 14 to 24.
3. Insertion of the relay.  
First the ejector (and eventually the module) has to be mounted onto the socket. Then the relay has to be set in the correct position and pressed into the socket until the ejector snaps over the top of the relay.
4. Standard polarity: A1:+, A2:-



# RT series (Sensitive)

## 10 Amp, 1 Pole PC Board Relay with 250mW Coil

US File E214025



Users should thoroughly review the technical data before selecting a product part number. It is recommended that users also seek out the pertinent approvals files of the agencies/laboratories and review them to ensure the product meets the requirements for a given application.

### Features

- Sensitive coil requires only 250mW.
- 10A contacts in 1 Form A (SPST-NO) or 1 Form C (SPDT) arrangement.
- UL Class F coil construction.
- 5kV/10mm contact-to-coil.

### Contact Data

**Arrangements:** 1 Form A (SPST-NO) or 1 Form C (SPDT), single contact.

**Material:** Silver-nickel 90/10.

**Expected Mechanical Life:** 30 million operations.

#### Ratings:

**Current:** 10A.

**Voltage:** 250VAC.

**Power (breaking):** 2,500 VA.

**Voltage (breaking):** 440VAC.

**Current (making, max. 4s at 10% duty cycle):** 15A.

#### Load/Life

8A, 250VAC; 430,000 ops.

370W, 230VAC, compressor, NO contact; >330,000 ops.

550W, 250VAC, incandescent, NO contact; 190,000 ops.

0.8A<sub>peak</sub> / 0.08A, 230VAC,  $\cos\phi=0.23$ ,

contactor 190 / 90 VA, NO contact; >8.8 million ops.

### Initial Dielectric Strength

**Between Open Contacts:** 1,000Vrms

**Between Coil and Contacts:** 5,000Vrms.

**Creepage/Clearance:** 10/10mm.

### Coil Data DC @ 20°C

**Nominal Coil Power:** 250mW.

Nominal Voltage VDC	DC Resistance in Ohms	Must Operate Voltage VDC	Drop-out Voltage VDC	Maximum Voltage VDC	Nominal Coil Current (mA)
5	100 ± 10%	3.7	0.5	15.0	50.0
6	144 ± 10%	4.5	0.6	18.0	41.7
12	576 ± 10%	9.0	1.2	36.0	20.8
24	2,304 ± 10%	18.0	2.4	72.0	10.4
48	9,216 ± 10%	36.0	4.8	144.0	5.4
60	12,857 ± 12%	45.0	6.0	180.0	4.7

### Operate Data

**Must Operate Voltage:** See Coil Data table.

**Operate Time (typical):** 7 ms.

**Release Time (typical):** 3 ms.

**Bounce Time (typical):** NO: 2 ms; NC: 4 ms.

**Switching Rate:** 3,600 ops./hr. max. at rated load.

### Environmental Data

**Temperature Range:**

**Operating:** -40°C to +85°C.

**Vibration (30-150 Hz.):** 5g.

**Shock (destructive):** 100g.

### Mechanical Data

**Termination:** Printed circuit terminals.

**Enclosure (94 V-0 Rated):** Flux-tight (RT II) or sealed (RT III) plastic case.

**Weight:** .49 oz. (14 g) approximately.

### Contact Life

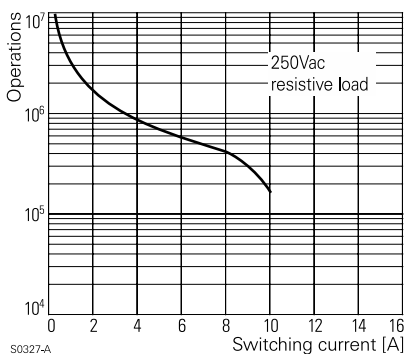

### Max. DC Load Breaking Capacity

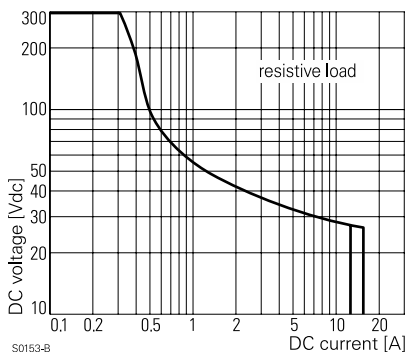

### Coil Operating Range

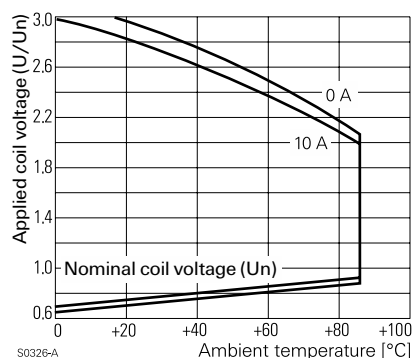

**Ordering Information**

Typical Part Number ▶

**RT 1 7 4 012**

**1. Basic Series:**

RT = Printed circuit board relay.

**2. Version:**

1 = 10A, 3.5mm pin spacing, flux-tight case.      B = 10A, 3.5mm pin spacing, sealed case.

**3. Contact Configuration:**

7 = 1 Form C (SPDT)      8 = 1 Form A (SPST-NO)

**4. Contact Material:**

4 = Silver-nickel 90/10.

**5. Coil Voltage:**

005 = 5VDC      012 = 12VDC      048 = 48VDC  
006 = 6VDC      024 = 24VDC      060 = 60VDC

**Stock Items – Authorized distributors are more likely to stock the following items.**

None at present.

**Outline Dimensions**

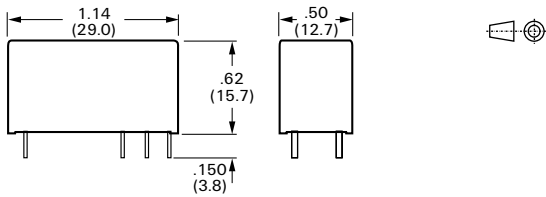

**Wiring Diagrams (Bottom Views)**

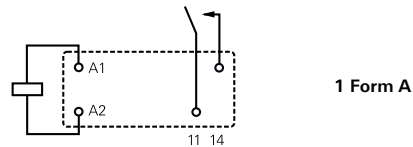
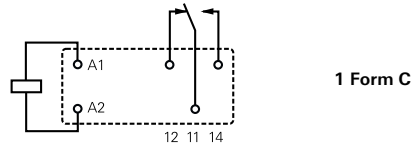

**PC Board Layouts (Bottom Views)**

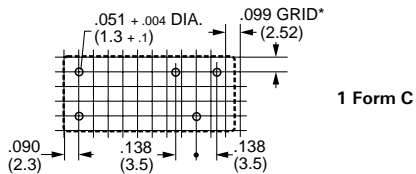

\* With the recommended hole size, a grid pattern from .0984 - .1 in (2.5 - 2.54 mm) can be used.

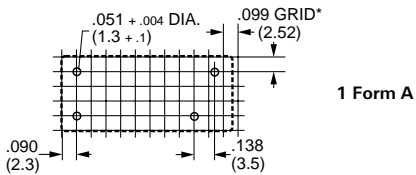

\* With the recommended hole size, a grid pattern from .0984 - .1 in (2.5 - 2.54 mm) can be used.



# RTH series

## 10-16 Amp, 1 Pole PC Board Relay for Operation to 105°C

US File E214025



Users should thoroughly review the technical data before selecting a product part number. It is recommended that users also seek out the pertinent approvals files of the agencies/laboratories and review them to ensure the product meets the requirements for a given application.

### Features

- Sensitive (250mW) version with 10A, 1 Form A (SPST-NO) contacts.
- 16A version with 1 Form A (SPST-NO) or 1 Form C (SPDT) contacts.
- UL Class F coil construction.
- 5kV/10mm contact-to-coil.
- DC coil.

### Contact Data

**Arrangements:** 1 Form A (SPST-NO) and 1 Form C (SPDT). 1 Form C not available with sensitive coil.

**Material:** Silver-nickel 90/10.

**Expected Mechanical Life:** 10 million operations.

### Ratings:

**Current: Standard Coil:** 16A; **Sensitive Coil:** 10A.

**Voltage:** 250VAC.

**Power (breaking): Standard Coil:** 4,000 VA; **Sensitive Coil:** 2,500VA.

**Voltage (breaking):** 440VAC.

**Current (making, max. 4s at 10% duty cycle):**

**Standard Coil:** 30A; **Sensitive Coil:** 15A.

**Load/Life – Standard Coil – Standard 1 Form A Contact**

10 amp, 250VAC, 105°C; 150,000 ops.

16 amp, 250VAC, 105°C; 20,000 ops.

**Load/Life – Standard Coil – High Performance 1 Form A Contact**

10 amp, 250VAC, 105°C; 300,000 ops.

16 amp ON / 8 amp OFF, 250VAC, 105°C; 250,000 ops.

**Load/Life – Sensitive Coil – 1 Form A Contact**

12 amp, 250VAC, 105°C, dry switching; >500,000 ops.

10 amp, 250VAC, cyclical heat 105/40°C; 200,000 ops.

10 amp, 250VAC, 105°C; 150,000 ops.

### Initial Dielectric Strength

**Between Open Contacts:** 1,000Vrms

**Between Coil and Contacts:** 5,000Vrms.

**Creepage/Clearance:** 10/10mm.

### Coil Data DC @ 20°C

**Nominal Coil Power: Sensitive Coil:** 250mW.; **Standard Coil:** 400mW†

† Standard coil continuous thermal load >10A at 105°C requires reduction of coil power to 64% of nominal after 100ms.

Nominal Voltage VDC	DC Resistance in Ohms ±10%	Must Operate Voltage VDC	Drop-out Voltage VDC	Maximum Voltage VDC	Nominal Coil Current (mA)
<b>Sensitive Coils (10A max. rating, 1 Form A only)</b>					
12	576	9.0	1.2	36.0	20.8
24	2,304	18.0	2.4	72.0	10.4
<b>Standard Coils (16A max. rating, 1 Form A or 1 Form C)</b>					
9	203	6.3	0.9	22.9	44.3
12	360	8.4	1.2	30.6	33.3
24	1,440	16.8	2.4	61.2	16.7

### Operate Data

**Must Operate Voltage:** See Coil Data table.

**Operate Time (typical): Standard Coil:** 7 ms.

**Sensitive Coil:** 8 ms.

**Release Time (typical): Standard or Sensitive Coil:** 3 ms.

**Bounce Time (typical): Standard Coil NO / NC:** 1 / 3 ms.

**Sensitive Coil:** 2 ms.

**Switching Rate:** 3,600 ops./hr. max. at rated load.

### Environmental Data

**Temperature Range:**

**Operating:** -40°C to +105°C.

**Vibration (30-150 Hz.): Standard Coil NO / NC:** 20 / 5g.

**Sensitive Coil:** 5g.

**Shock (destructive):** 100g.

### Mechanical Data

**Termination:** Printed circuit terminals.

**Enclosure (94 V-0 Rated):** Flux-tight (RT II) plastic case.

**Weight:** .49 oz. (14 g) approximately.

### Contact Life

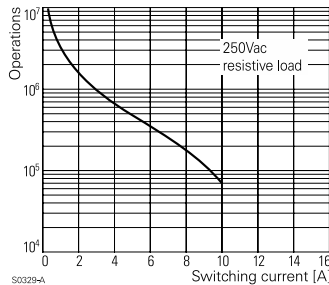

Models with Sensitive Coil

### Max. DC Load Breaking Capacity

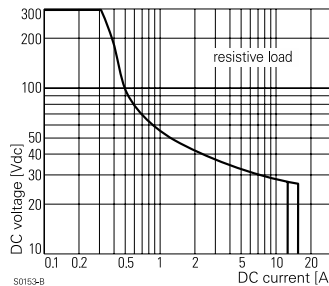

Models with Standard Coil

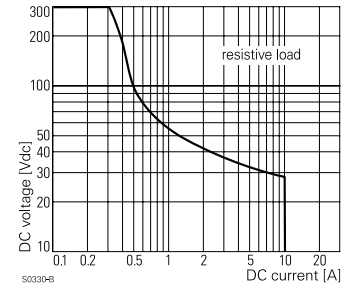

Models with Sensitive Coil

### Coil Operating Range

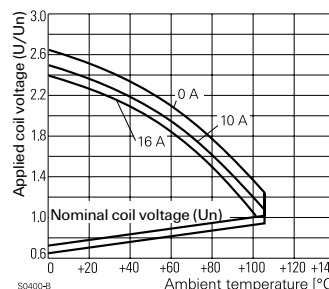

Models with Standard Coil

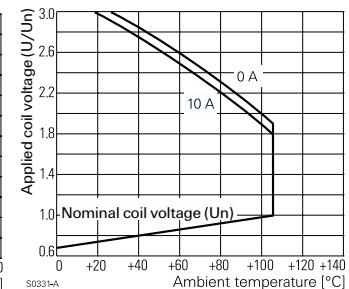

Models with Sensitive Coil

**Ordering Information**

<b>Typical Part Number</b> ▶	<b>RTH</b>	<b>1</b>	<b>4</b>	<b>012</b>
<p><b>1. Basic Series:</b> RTH = Printed circuit board relay for high temperature (105°C) applications.</p> <p><b>2. Coil Type and Contacts:</b>                  1 = Standard coil, standard 1 Form C (SPDT) contacts, 16A rating                  3 = Standard coil, standard 1 Form A (SPST-NO) contacts, 16A rating                  H = Standard coil, "high performance" 1 Form A (SPST-NO) contacts, 16A rating                  8 = Sensitive coil, standard 1 Form A (SPST-NO) contacts, 10A rating</p> <p><b>3. Contact Material:</b> 4 = Silver-nickel 90/10.</p> <p><b>4. Coil Voltage:</b>                  009 = 9VDC (standard version coil only)      012 = 12VDC      024 = 24VDC</p>				

**Our authorized distributors are more likely to maintain the following items in stock for immediate delivery.**

None at present.

**Outline Dimensions**

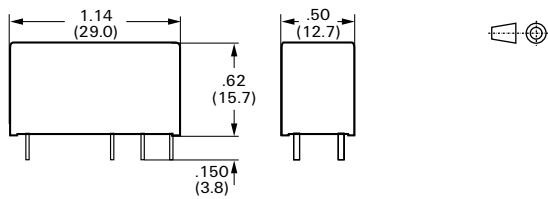

**Wiring Diagrams (Bottom Views)**

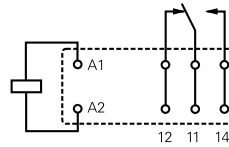

**1 Form C, Standard Coil Only**

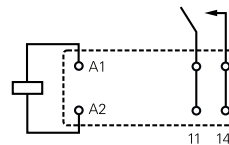

**1 Form A, Standard or Sensitive Coil**

**PC Board Layouts (Bottom Views)**

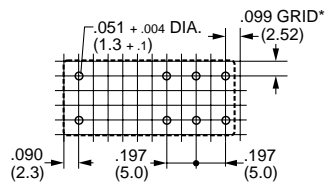

**1 Form C, Standard Coil Only**

\* With the recommended hole size, a grid pattern from .0984 - .1 in (2.5 - 2.54 mm) can be used.

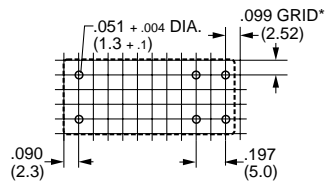

**1 Form A, Standard or Sensitive Coil**

\* With the recommended hole size, a grid pattern from .0984 - .1 in (2.5 - 2.54 mm) can be used.



# RT series (High Inrush)

## 16 Amp, 1 Pole PC Board Relay for Inrush Currents to 80A

UL File E214025



Users should thoroughly review the technical data before selecting a product part number. It is recommended that users also seek out the pertinent approvals files of the agencies/laboratories and review them to ensure the product meets the requirements for a given application.

### Features

- Capable of handling 80A inrush currents.
- 16A, 1 Form A (SPST-NO) contacts.
- UL Class F coil construction.
- 5kV/10mm contact-to-coil.
- 400mW DC coil.

### Contact Data

**Arrangements:** 1 Form A (SPST-NO), single contact.

**Material:** Silver-nickel 90/10 or Silver-tin oxide.

**Expected Mechanical Life:** 30 million operations.

#### Ratings:

**Current:** 16A.

**Voltage:** 250VAC.

**Power (breaking):** 4,000 VA.

**Voltage (breaking):** 440VAC.

**Current (making, max. 4s at 10% duty cycle):** 30A.

**Peak Inrush Current (20ms):** 80A.

#### Load/Life – Silver-nickel contacts

1000W, 250VAC, incandescent lamps; 90,000 ops.

#### Load/Life – Silver-tin oxide contacts

1000W, 250VAC, incandescent lamps; 80,000 ops.

Compressor, 230VAC,  $I_{in} \leq 21A_{peak}$ ,  $I_{off} = 3.5A$ ,  $\cos\phi = 0.5$ ; 230,000 ops.

### Initial Dielectric Strength

**Between Open Contacts:** 1,000Vrms

**Between Coil and Contacts:** 5,000Vrms.

**Creepage/Clearance:** 10/10mm.

### Coil Data DC @ 20°C

**Nominal Coil Power:** 400mW.

Nominal Voltage VDC	DC Resistance in Ohms	Must Operate Voltage VDC	Drop-out Voltage VDC	Maximum Voltage VDC	Nominal Coil Current (mA)
12	360 ± 10%	8.4	1.2	30.6	33.3
24	1,440 ± 10%	16.8	2.4	61.2	16.7
48	5,520 ± 10%	33.6	4.8	122.4	8.7
60	7,340 ± 12%	42.0	6.0	153.0	8.1

### Operate Data

**Must Operate Voltage:** See Coil Data table.

**Operate Time (typical):** 8 ms.

**Release Time (typical):** 3 ms.

**Bounce Time (typical):** 2 ms.

**Switching Rate:** 3,600 ops./hr. max. at rated load.

### Environmental Data

**Temperature Range:**

**Operating:** -40°C to +85°C.

**Vibration (30-500 Hz.):** 20g.

**Shock (destructive):** 100g.

### Mechanical Data

**Termination:** Printed circuit terminals.

**Enclosure (94 V-0 Rated):** Flux-tight (RT II) plastic case.

**Weight:** .49 oz. (14 g) approximately.

### Contact Life

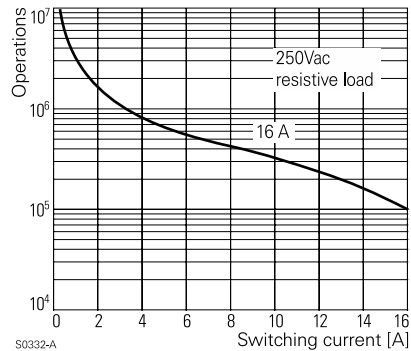

### Max. DC Load Breaking Capacity

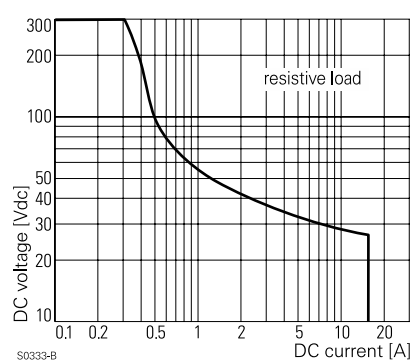

### Coil Operating Range

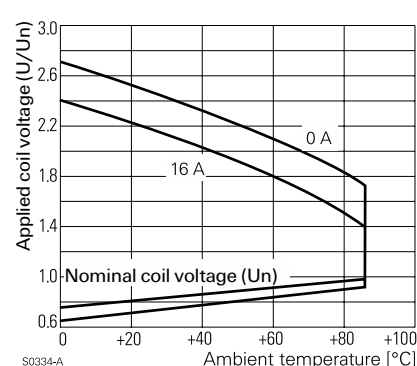

**Ordering Information**

Typical Part Number ▶

**RT 3 3 K 012**

**1. Basic Series:**

RT = Printed circuit board relay.

**2. Version:**

3 = 16A, 5mm pin spacing, flux-tight case.

**3. Contact Configuration:**

3 = 1 Form A (SPST:NO)

**4. Contact Material:**

K = Silver-nickel 90/10 contacts for high inrush currents. L = Silver-tin oxide contacts for high inrush currents.

**5. Coil Voltage:**

012 = 12VDC      048 = 48VDC  
024 = 24VDC      060 = 60VDC

**Our authorized distributors are more likely to maintain the following items in stock for immediate delivery.**

None at present.

**Outline Dimensions**

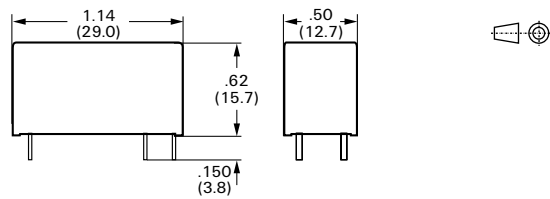

**Wiring Diagram (Bottom View)**

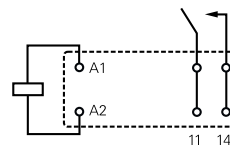

**PC Board Layout (Bottom View)**

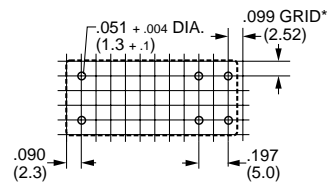

\* With the recommended hole size, a grid pattern from .0984 - .1 in (2.5 - 2.54 mm) can be used.



# 0429 series

## High Inrush (80A/20ms), Miniature Printed Circuit Board Relay

File E214025

Users should thoroughly review the technical data before selecting a product part number. It is recommended that users also seek out the pertinent approvals files of the agencies/laboratories and review them to ensure the product meets the requirements for a given application.

### Features

- 1 Form A (SPST-NO).
- Tungsten prerun contact and silver-tin oxide contact.
- 10 amp rated current, 80A/20ms inrush current.
- 4kV/8mm contact-to-coil, insulation to VDE 0631 and 0700.
- Sensitive coil (480mW).
- Low-profile (.59 in [15 mm]) flux-tight case.
- Well suited for lighting systems, motors, lamp loads.

### Contact Data

**Arrangements:** 1 Form A (SPST-NO), single contact.  
**Material:** Tungsten prerun contact and silver-tin oxide contact.  
**Expected Mechanical Life:** 5 million operations.  
**Ratings:**

- Current:** 10A.
- Current (making, max. 4s at 10% duty cycle):** 16A.
- Current (peak inrush 20ms):** 80A.
- Voltage:** 250VAC.
- Voltage (breaking):** 400VAC.
- Load/Life**
  - 10 amp resistive, 250VAC, 50,000 ops.
  - 2,500W, incandescent lamps, 30,000 ops.
  - 1,300W, fluorescent lamps (140µF), 30,000 ops.
  - 1,000W, Dulux lamps (140µF), 30,000 ops.

### Initial Dielectric Strength

**Between Open Contacts:** 1,000Vrms.  
**Between Coil and Contacts:** 4,000Vrms.  
**Creepage/Clearance:** 8/8mm.

### Coil Data DC @ 20°C

**Nominal Coil Power:** 480mW.

Nominal Voltage VDC	DC Resistance in Ohms ±10%	Must Operate Voltage VDC	Drop-out Voltage VDC	Maximum Voltage VDC	Nominal Coil Current (mA)
6	80	4.2	0.4	12.0	75.0
12	300	8.4	0.9	24.0	40.0
24	1,200	16.8	1.8	48.0	20.0
48	4,825	33.6	3.6	96.0	10.0
60	7,500	42.0	4.5	120.0	8.0

### Operate Data

- Must Operate Voltage:** See Coil Data table.
- Operate Time (typical):** 6 ms.
- Release Time (typical):** 4 ms.
- Bounce Time (typical):** 3 ms.
- Switching Rate:** 6,000 ops./hr. max. at rated load.

### Environmental Data

- Temperature Range:**
- Operating:** -40°C to +70°C.
- Shock (destructive):** 100g.

### Mechanical Data

- Termination:** Printed circuit terminals.
- Enclosure (94 V-0 rated):** Flux-tight (RTII) plastic case.
- Weight:** 0.35 oz. (10 g) approximately.

### Coil Operating Range

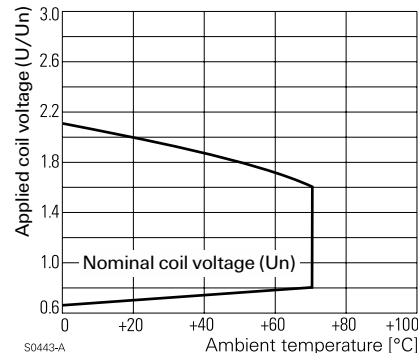

### Ordering Information

Typical Part Number ►

0429 03

13

12

00

#### 1. Basic Series:

0429 03 = Miniature printed circuit board relay for high inrush currents.

#### 2. Coil Voltage:

16 = 6VDC      13 = 12VDC      08 = 24VDC      05 = 48VDC      03 = 60VDC

#### 3. Contact Material:

12 = Tungsten prerun contact and silver-tin oxide contact.

#### 4. Version:

00 = Standard

**Our authorized distributors are more likely to stock the following items for immediate delivery.**

None at present.

### Outline Dimensions

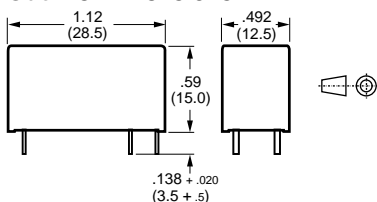

### PC Board Layout (Bottom View)

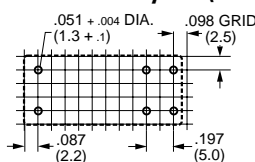

### Wiring Diagram (Bottom View)

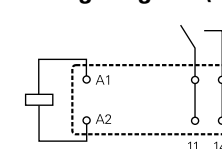

# OMI/OMIH series

## 16A Miniature Power PC Board Relay

Appliances, HVAC, Office Machines.



UL File No. E58304

CSA File No. LR48471

VDE File No. 6678

SEMKO File No. 9517235 (OMI)  
9143112 (OMIH)

Users should thoroughly review the technical data before selecting a product part number. It is recommended that user also seek out the pertinent approvals files of the agencies/laboratories and review them to ensure the product meets the requirements for a given application.

### Features

- Meet UL 508, VDE0435 and SEMKO requirements.
- 1 Form A and 1 Form C contact arrangements.
- Immersion cleanable, sealed version available.
- Meet 5,000V dielectric voltage between coil and contacts.
- Meet 10,000V surge voltage between coil and contacts (1.2 / 50µs).

### Contact Data @ 20°C

**Arrangements:** 1 Form A (SPST-NO) and 1 Form C (SPDT).  
**Material:** Ag Alloy (OMI), AgSnO (OMIH).

**Max. Switching Rate:** 300 ops./min. (no load).  
30 ops./min. (rated load).

**Expected Mechanical Life:** 10 million operations (no load).

**Expected Electrical Life:** 100,000 operations (rated load).

**Minimum Load:** 100mA @ 5VDC.

**Initial Contact Resistance:** 100 milliohms @ 1A, 6VDC.

### Contact Ratings

**Ratings: OMI:** 10A @ 240VAC resistive,  
10A @ 30VDC resistive,  
3A @ 240VAC inductive (cosφ= 0.4),  
3A @ 30VDC inductive (L/R=7msec).  
**OMIH:** 16A @ 240VAC resistive,  
16A @ 30VDC resistive,  
4A @ 240VAC inductive (cosφ= 0.4),  
4A @ 24VDC inductive (L/R=7msec).

**Max. Switched Voltage: AC:** 250V.  
**DC:** 30V.

**Max. Switched Current:** 10A (OMI), 16A (OMIH).

**Max. Switched Power: OMI:** 2,400VA, 300W.  
**OMIH:** 3,800VA, 480W.

### Initial Dielectric Strength

**Between Open Contacts:** 1,000VAC 50/60 Hz. (1 minute).  
**Between Coil and Contacts:** 5,000VAC 50/60 Hz. (1 minute).  
**Surge Voltage Between Coil and Contacts:** 10,000V (1.2 / 50µs).

### Initial Insulation Resistance

**Between Mutually Insulated Elements:** 1,000M ohms min. @ 500VDC.

### Coil Data

**Voltage:** 5 to 48VDC.  
**Nominal Power:** 720 mW (OMI-D), 540mW (OMI-L).  
**Coil Temperature Rise:** 45°C max., at rated coil voltage.  
**Max. Coil Power:** 130% of nominal.  
**Duty Cycle:** Continuous.

### Coil Data @ 20°C

OMI/OMIH-L Sensitive				
Rated Coil Voltage (VDC)	Nominal Current (mA)	Coil Resistance (ohms) ± 10%	Must Operate Voltage (VDC)	Must Release Voltage (VDC)
5	106.4	47	3.75	0.50
6	88.0	68	4.50	0.60
9	58.0	155	6.75	0.90
12	44.4	270	9.00	1.20
24	21.8	1,100	18.00	2.40
48	10.9	4,400	36.00	4.80
OMI/OMIH-D Standard				
Rated Coil Voltage (VDC)	Nominal Current (mA)	Coil Resistance (ohms) ± 10%	Must Operate Voltage (VDC)	Must Release Voltage (VDC)
5	138.9	36	3.50	0.50
6	120.0	50	4.20	0.60
9	78.3	115	6.30	0.90
12	60.0	200	8.40	1.20
24	29.3	820	16.80	2.40
48	14.5	3,300	33.60	4.80

### Operate Data

**Must Operate Voltage:**  
**OMI/OMIH-D:** 70% of nominal voltage or less.  
**OMI/OMIH-L:** 75% of nominal voltage or less.  
**Must Release Voltage:** 5% of nominal voltage or more.  
**Operate Time: OMI/OMIH-D:** 15 ms max.  
**OMI/OMIH-L:** 20 ms max.  
**Release Time:** 8 ms max.

### Environmental Data

**Temperature Range:**  
**Operating: OMI/OMIH-D:** -30°C to +55°C  
**OMI/OMIH-L:** -30°C to +70 °C  
**Vibration, Mechanical:** 10 to 55 Hz., 1.5mm double amplitude  
**Operational:** 10 to 55 Hz., 1.5mm double amplitude.  
**Shock, Mechanical:** 1,000m/s<sup>2</sup> (100G approximately).  
**Operational:** 100m/s<sup>2</sup> (10G approximately).  
**Operating Humidity:** 20 to 85% RH. (Non-condensing).

### Mechanical Data

**Termination:** Printed circuit terminals.  
**Enclosure (94V-0 Flammability Ratings):**  
**OMI/OMIH-SS:** Vented (Flux-tight) plastic cover.  
**OMI/OMIH-SH:** Sealed plastic case.  
**Weight:** 0.46 oz (13g) approximately.

**Ordering Information**

<b>Typical Part Number ▶</b>			<b>OMIH</b>	<b>-SH</b>	<b>-1</b>	<b>24</b>	<b>L</b>	<b>,294</b>
<b>1. Basic Series:</b>								
OMI = 10A rating			OMIH = 16A rating					
<b>2. Enclosure:</b>								
SS = Vent (Flux-tight)* plastic cover.								
SH = Sealed, plastic case.								
<b>3. Termination:</b>								
1 = 1 pole								
<b>4. Coil Voltage:</b>								
05 = 5VDC			09 = 9VDC			24 = 24VDC		
06 = 6VDC			12 = 12VDC			48 = 48VDC		
<b>5. Coil Input:</b>								
D = Standard (720mW)			L = Sensitive (540mW)					
<b>6. Contact Arrangement:</b>								
Blank = 1 Form C, SPDT			M = 1 Form A, SPST-NO					
<b>7. Suffix:</b>								
,300 = Standard model for "SS" enclosure			,394 = Standard model for "SH" enclosure			Other Suffix = Custom model		

**Our authorized distributors are more likely to stock the following items for immediate delivery.**

- OMIH-SH-105D,394    OMIH-SH-105L,394
- OMIH-SH-112D,394    OMIH-SH-112L,394
- OMIH-SH-124D,394    OMIH-SH-124L,394

**Outline Dimensions**

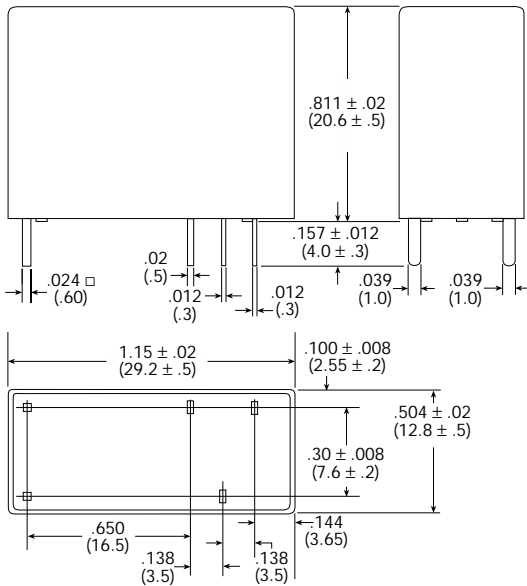

**Wiring Diagram (Bottom View)**

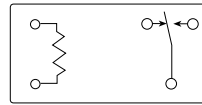

**PC Board Layout (Bottom View)**

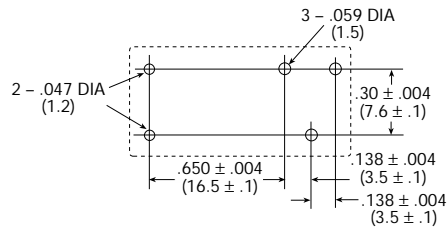

**Reference Data**

**Coil Temperature Rise**

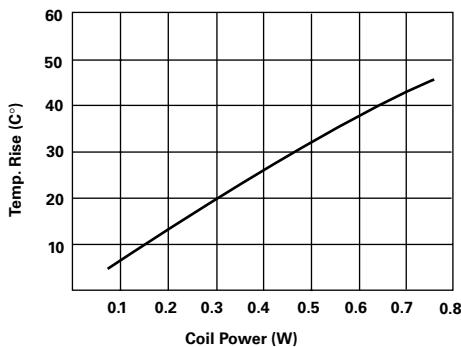

**Operate Time**

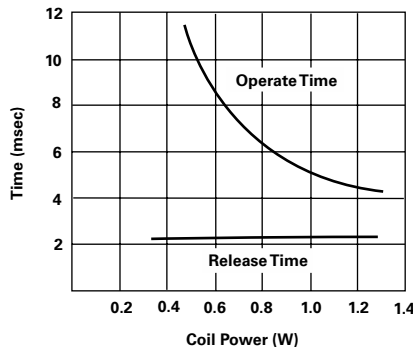

**Life Expectancy**

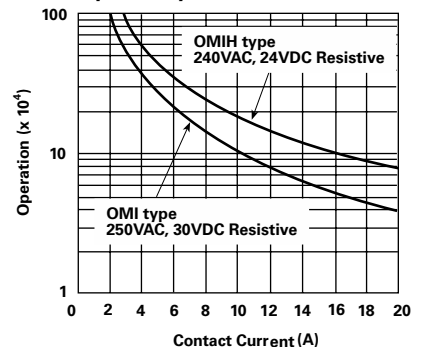

Dimensions are shown for reference purposes only.

Dimensions are in inches over (millimeters) unless otherwise specified.

Specifications and availability subject to change.

www.tycoelectronics.com  
 Technical support:  
 Refer to inside back cover.

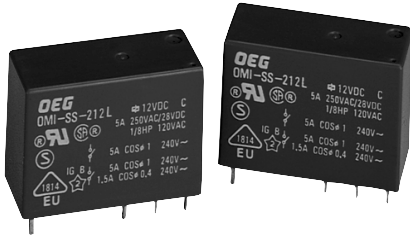

# OMI 2 Pole series

## 2 Pole Miniature Power PC Board Relay

Appliances, HVAC, Office Machines.

UL File No. E58304

CSA File No. LR48471

VDE File No. 6678

SEMKO File No. 9517235

Users should thoroughly review the technical data before selecting a product part number. It is recommended that user also seek out the pertinent approvals files of the agencies/laboratories and review them to ensure the product meets the requirements for a given application.

### Features

- Meet UL 508, VDE0435 and SEMKO requirements.
- 2 Form A and 2 Form C contact arrangements.
- Immersion cleanable, sealed version available.
- Meet 5,000V dielectric voltage between coil and contacts.
- Meet 10,000V surge voltage between coil and contacts (1.2 / 50µs).

### Contact Data @ 20°C

**Arrangements:** 2 Form A (DPST-NO) and 2 Form C (DPDT).

**Material:** Ag Alloy.

**Max. Switching Rate:** 300 ops./min. (no load).  
30 ops./min. (rated load).

**Expected Mechanical Life:** 10 million operations (no load).

**Expected Electrical Life:** 100,000 operations (rated load).

**Minimum Load:** 100mA @ 5VDC.

**Initial Contact Resistance:** 100 milliohms @ 1A, 6VDC.

### Contact Ratings

**Ratings:** 5A @ 240VAC resistive,  
5A @ 120VAC resistive,  
5A @ 30VDC resistive,  
1/8 HP @ 250VAC.

1.5A @ 240VAC inductive (cosφ = 0.4),  
1.5A @ 120VAC inductive (cosφ = 0.4),  
1.5A @ 24VDC inductive (L/R=7msec).

**Max. Switched Voltage:** AC: 240V.  
DC: 30V.

**Max. Switched Current:** 5A.

**Max. Switched Power:** OMI: 1,200VA, 150W.

### Initial Dielectric Strength

**Between Open Contacts:** 1,000VAC 50/60 Hz. (1 minute).

**Between Coil and Contacts:** 5,000VAC 50/60 Hz. (1 minute).

**Surge Voltage Between Coil and Contacts:** 10,000V (1.2 / 50µs).

### Initial Insulation Resistance

**Between Mutually Insulated Elements:** 1,000M ohms min. @ 500VDCM.

### Coil Data

**Voltage:** 5 to 48VDC.

**Nominal Power:** 720mW (OMI-D), 540mW (OMI-L).

**Coil Temperature Rise:** 45°C max., at rated coil voltage.

**Max. Coil Power:** 130% of nominal.

**Duty Cycle:** Continuous.

### Coil Data @ 20°C

OMI-L Sensitive				
Rated Coil Voltage (VDC)	Nominal Current (mA)	Coil Resistance (ohms) ± 10%	Must Operate Voltage (VDC)	Must Release Voltage (VDC)
5	106.4	47	4.00	0.50
6	88.0	68	4.80	0.60
9	58.0	155	7.20	0.90
12	44.4	270	9.60	1.20
24	21.8	1,100	19.20	2.40
48	10.9	4,400	38.40	4.80
OMI-D Standard				
Rated Coil Voltage (VDC)	Nominal Current (mA)	Coil Resistance (ohms) ± 10%	Must Operate Voltage (VDC)	Must Release Voltage (VDC)
5	138.9	36	3.75	0.50
6	120.0	50	4.50	0.60
9	78.3	115	6.75	0.90
12	60.0	200	9.00	1.20
24	29.3	820	18.00	2.40
48	14.5	3,300	36.00	4.80

### Operate Data

**Must Operate Voltage:**

OMI-D: 75% of nominal voltage or less.

OMI-L: 80% of nominal voltage or less.

**Must Release Voltage:** 5% of nominal voltage or more.

**Operate Time:** OMI-D: 15 ms max.

OMI-L: 20 ms max.

**Release Time:** 8 ms max.

### Environmental Data

**Temperature Range:**

**Operating:** OMI-D:  
-30°C to +55°C

OMI-L:  
-30°C to +70 °C

**Vibration, Mechanical:** 10 to 55 Hz., 1.5mm double amplitude

**Operational:** 10 to 55 Hz., 1.5mm double amplitude.

**Shock, Mechanical:** 1,000m/s<sup>2</sup> (100G approximately).

**Operational:** 100m/s<sup>2</sup> (10G approximately).

**Operating Humidity:** 20 to 85% RH. (Non-condensing).

### Mechanical Data

**Termination:** Printed circuit terminals.

**Enclosure (94V-0 Flammability Ratings):**

OMI-SS: Vented (Flux-tight) plastic cover.

OMI-SH: Sealed plastic case.

**Weight:** 0.46 oz (13g) approximately.

**Ordering Information**

Typical Part Number ▶

**OMI -SS -2 12 L M ,594**

**1. Basic Series:**

OMI = 2 Pole Miniature Power PC Board Relay.

**2. Enclosure:**

SS = Vent (Flux-tight)\* plastic cover.  
SH = Sealed, plastic case.

**3. Termination:**

2 = 2 pole

**4. Coil Voltage:**

05 = 5VDC      09 = 9VDC      24 = 24VDC  
06 = 6VDC      12 = 12VDC      48 = 48VDC

**5. Coil Input:**

D = Standard (720mW)      L = Sensitive (540mW)

**6. Contact Arrangement:**

Blank = 2 Form C, DPDT      M = 2 Form A, DPST-NO

**7. Suffix:**

,500 = Standard model for "SS" enclosure      ,594 = Standard model for "SH" enclosure      Other Suffix = Custom model

\* Not suitable for immersion cleaning processes.

**Our authorized distributors are more likely to stock the following items for immediate delivery.**

OMI-SH-205D,594    OMI-SH-205L,594  
OMI-SH-212D,594    OMI-SH-212L,594  
OMI-SH-224D,594    OMI-SH-224L,594

**Outline Dimensions**

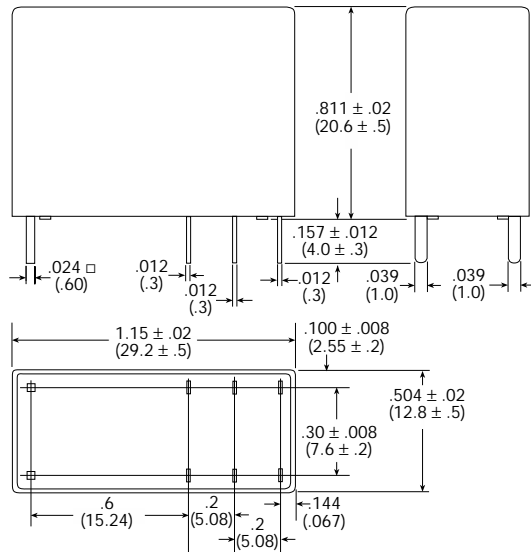

**Wiring Diagram (Bottom View)**

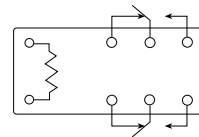

**PC Board Layout (Bottom View)**

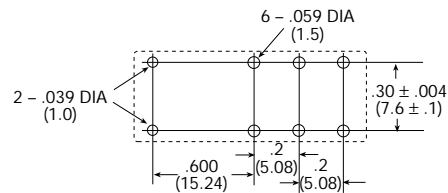

**Reference Data**

**Coil Temperature Rise**

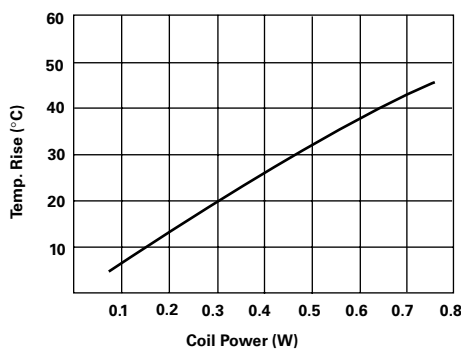

**Operate Time**

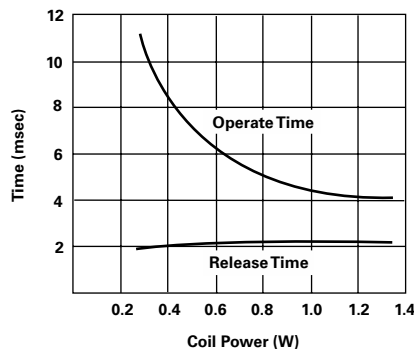

**Life Expectancy**

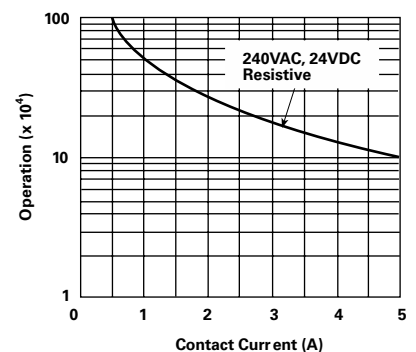

Dimensions are shown for reference purposes only.

Dimensions are in inches over (millimeters) unless otherwise specified.

Specifications and availability subject to change.

www.tycoelectronics.com  
Technical support:  
Refer to inside back cover.

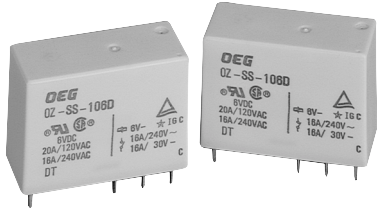

# OZ/OZF series

## 16A Miniature Power PC Board Relay

Appliances, HVAC, Office Machines.

UL File No. E82292

CSA File No. LR48471

TUV File No. R85447

Users should thoroughly review the technical data before selecting a product part number. It is recommended that user also seek out the pertinent approvals files of the agencies/laboratories and review them to ensure the product meets the requirements for a given application.

### Features

- Meet UL 508, CSA and TUV requirements.
- 1 Form A and 1 Form C contact arrangements.
- Immersion cleanable, sealed version available.
- Meet 5,000V dielectric voltage between coil and contacts.
- Meet 10,000V surge voltage between coil and contacts (1.2 / 50µs).
- Quick Connect Terminal type available (OZF).
- UL TV-8 rating available (OZT).

### Contact Data @ 20°C

**Arrangements:** 1 Form A (SPST-NO) and 1 Form C (SPDT).

**Material:** Ag Alloy (1 Form C) and AgSnO (1 Form A).

**Max. Switching Rate:** 300 ops./min. (no load).  
30 ops./min. (rated load).

**Expected Mechanical Life:** 10 million operations (no load).

**Expected Electrical Life:** 100,000 operations (rated load).

**Minimum Load:** 100mA @ 5VDC.

**Initial Contact Resistance:** 100 milliohms @ 1A, 6VDC.

### Contact Ratings

**Ratings: OZ/OZF:** 20A @ 120VAC resistive,  
16A @ 240VAC resistive,  
5A @ 120VAC inductive (cosφ= 0.4),  
5A @ 24VDC inductive (L/R= 7msec).

**OZT:** 8A @ 240VAC resistive,  
TV-8 @ 120VAC tungsten, 25,000ops.

**Max. Switched Voltage: AC:** 240V.  
DC: 110V.

**Max. Switched Current:** 16A (OZ/OZF), 8A (OZT).

**Max. Switched Power:** 3,850VA, 600W.

### Initial Dielectric Strength

**Between Open Contacts:** 1,000VAC 50/60 Hz. (1 minute).

**Between Coil and Contacts:** 5,000VAC 50/60 Hz. (1 minute).

**Surge Voltage Between Coil and Contacts:** 10,000V (1.2 / 50µs).

### Initial Insulation Resistance

**Between Mutually Insulated Elements:** 1,000M ohms min. @ 500VDC.

### Coil Data

**Voltage:** 5 to 48VDC.

**Nominal Power:** 720 mW (OZ-D), 540mW (OZ-L).

**Coil Temperature Rise:** 45°C max., at rated coil voltage.

**Max. Coil Power:** 130% of nominal.

**Duty Cycle:** Continuous.

### Coil Data @ 20°C

OZ-L Sensitive				
Rated Coil Voltage (VDC)	Nominal Current (mA)	Coil Resistance (ohms) ± 10%	Must Operate Voltage (VDC)	Must Release Voltage (VDC)
5	106.4	47	3.75	0.25
6	88.0	68	4.50	0.30
9	58.0	155	6.75	0.45
12	44.4	270	9.00	0.60
24	21.8	1,100	18.00	1.20
48	10.9	4,400	36.00	2.40
OZ-D Standard				
Rated Coil Voltage (VDC)	Nominal Current (mA)	Coil Resistance (ohms) ± 10%	Must Operate Voltage (VDC)	Must Release Voltage (VDC)
5	138.9	36	3.50	0.25
6	120.0	50	4.20	0.30
9	78.3	115	6.30	0.45
12	60.0	200	8.40	0.90
24	29.3	820	16.80	1.20
48	14.5	3,300	33.60	2.40

### Operate Data

**Must Operate Voltage:**

**OZ-D:** 70% of nominal voltage or less.

**OZ-L:** 75% of nominal voltage or less.

**Must Release Voltage:** 5% of nominal voltage or more.

**Operate Time: OZ-D:** 15 ms max.

**OZ-L:** 20 ms max.

**Release Time:** 8 ms max.

### Environmental Data

**Temperature Range:**

**Operating: OZ-D:** -30°C to +55°C

**OZ-L:** -30°C to +70 °C

**Vibration, Mechanical:** 10 to 55 Hz., 1.5mm double amplitude

**Operational:** 10 to 55 Hz., 1.5mm double amplitude.

**Shock, Mechanical:** 1,000m/s<sup>2</sup> (10G approximately).

**Operational:** 100m/s<sup>2</sup> (10G approximately).

**Operating Humidity:** 20 to 85% RH. (Non-condensing).

### Mechanical Data

**Termination:** Printed circuit terminals.

**Enclosure (94V-0 Flammability Ratings):**

**OZ-S:** Vented (Flux-tight) plastic cover.

**OZF-SS:** Vented (Flux-tight) plastic cover.

**OZ-SH:** Sealed plastic case.

**Weight:** 0.46 oz (13g) approximately.

**Ordering Information**

Typical Part Number ▶

**OZ -SH -1 24 L M 1 ,294**

<b>1. Basic Series:</b> OZ = 16A PC Board Terminals      OZF = Quick Connect Terminals OZT = TV-8 Rating PC Board Terminals		
<b>2. Enclosure:</b> S = Vent (Flux-tight)* plastic cover (only available with OZF) SS = Vent (Flux-tight)* plastic cover.      SH = Sealed, plastic case.		
<b>3. Termination:</b> 1 = 1 pole		
<b>4. Coil Voltage:</b> 05 = 5VDC      09 = 9VDC      24 = 24VDC 06 = 6VDC      12 = 12VDC      48 = 48VDC		
<b>5. Coil Input:</b> D = Standard (720mW)      L = Sensitive (540mW)		
<b>6. Contact Arrangement:</b> Blank = 1 Form C, SPDT      M = 1 Form A, SPST-NO		
<b>7. Contact Material:</b> Blank = AgCdO (1 Form C)      1 = AgSnO (1 Form A, only available with OZ....LM1 or DM1)		
<b>8. Mounting and Termination:</b> Blank = PC Board Terminals      P = PC Board and Quick Connect Terminals (only available only with OZF-S-1..LM1P).		
<b>9. Suffix:</b> .200 = Standard model for "SS" enclosure on OZ and OZT      ,000 = Standard model for coil input "D" on OZF      Other Suffix = Custom model .294 = Standard model for "SH" enclosure on OZ and OZT      ,300 = Standard model for coil input "L" on OZF		

\* Not suitable for immersion cleaning processes.

**Our authorized distributors are more likely to maintain the following items in stock for immediate delivery.**

- |                |                  |                  |                |                |
|----------------|------------------|------------------|----------------|----------------|
| OZ-SH-105D,294 | OZ-SH-124D,294   | OZ-SH-112LM1,294 | OZ-SH-105L,294 | OZ-SH-124L,294 |
| OZ-SH-112D,294 | OZ-SH-105LM1,294 | OZ-SH-124LM1,294 | OZ-SH-112L,294 |                |

**Outline Dimensions**

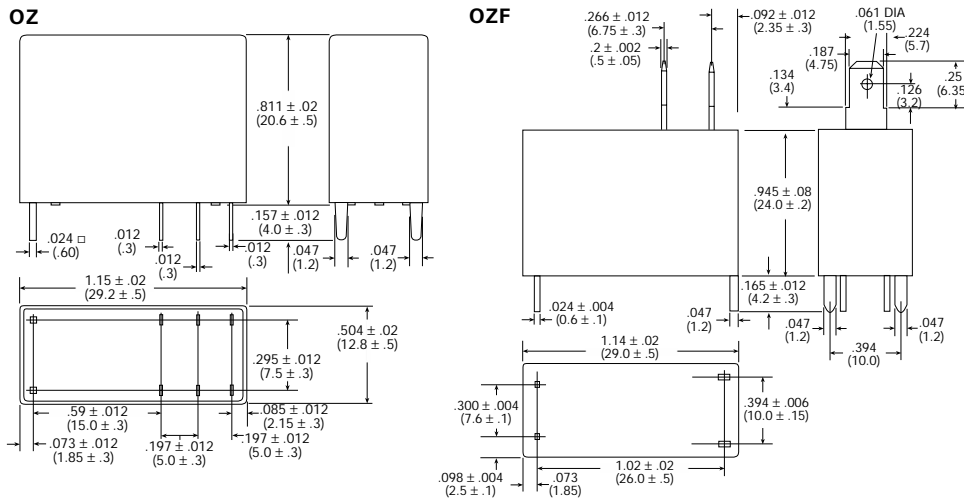

**PC Board Layouts (Bottom View)**

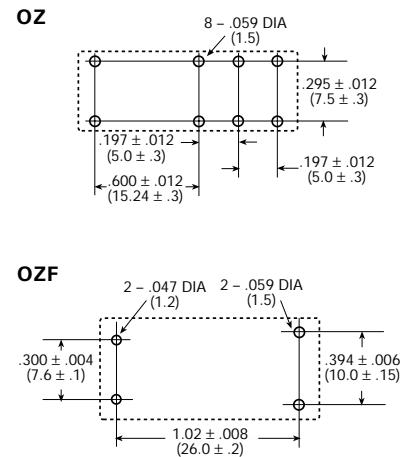

**Wiring Diagrams**

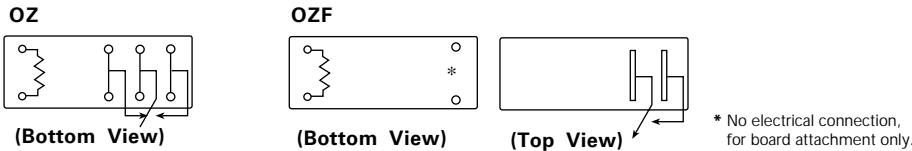

**Reference Data**

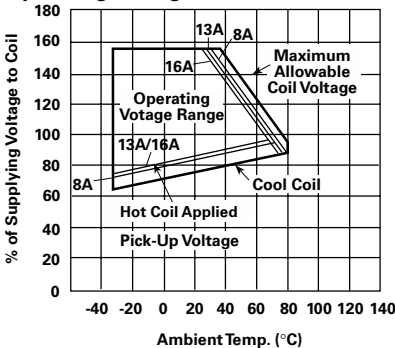

Note: This data is based on the max. allowable temperature for E type insulation coil (115°C).

**Operate Time**

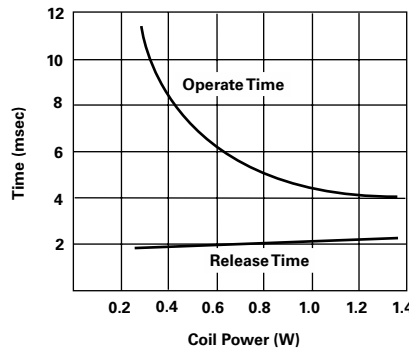

**Life Expectancy**

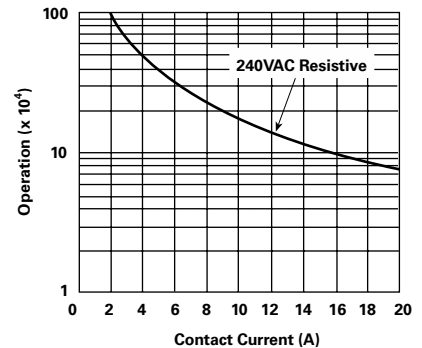

Dimensions are shown for reference purposes only.

Dimensions are in inches over (millimeters) unless otherwise specified.

Specifications and availability subject to change.

www.tycoelectronics.com  
Technical support:  
Refer to inside back cover.

# OMIT series

## 10A Miniature Power PC Board Relay

Appliances, HVAC, Office Machines.



UL File No. E58304

CSA File No. LR48471

VDE File No. 6678

SEMKO File No. 8713114

SEV File No. 97550375

Users should thoroughly review the technical data before selecting a product part number. It is recommended that user also seek out the pertinent approvals files of the agencies/laboratories and review them to ensure the product meets the requirements for a given application.

### Features

- Meet UL 508, VDE0435, SEMKO and SEV requirements.
- 1 Form A contact arrangements.
- UL TV-5 rating available.
- Immersion cleanable, sealed version available.
- Meet 5,000V dielectric voltage between coil and contacts.
- Meet 10,000V surge voltage between coil and contacts (1.2 / 50µs).

### Contact Data @ 20°C

Arrangements: 1 Form A.

Material: AgSnO

Max. Switching Rate: 300 ops./min. (no load).  
30 ops./min. (rated load).

Expected Mechanical Life: 10 million operations (no load).

Expected Electrical Life: 100,000 operations (rated load).

Minimum Load: 100mA @ 5VDC.

Initial Contact Resistance: 100 milliohms @ 1A, 6VDC.

### Contact Ratings

Ratings: 10A @ 240VAC resistive,  
TV-5 @ 120VAC tungsten 25,000ops.

Max. Switched Voltage: AC: 240V.  
DC: 30V.

Max. Switched Current: 10A.

Max. Switched Power: 2,400VA, 300W.

### Initial Dielectric Strength

Between Open Contacts: 1,000VAC 50/60 Hz. (1 minute).

Between Coil and Contacts: 5,000VAC 50/60 Hz. (1 minute).

Surge Voltage Between Coil and Contacts: 10,000V (1.2 / 50µs).

### Initial Insulation Resistance

Between Mutually Insulated Elements: 1,000M ohms min. @ 500VDC.

### Coil Data

Voltage: 5 to 48VDC.

Nominal Power: 720 mW (OMI-D), 540mW (OMI-L).

Coil Temperature Rise: 45°C max., at rated coil voltage (OMI-D).  
35°C max., at rated coil voltage (OMI-L).

Max. Coil Power: 130% of nominal.

Duty Cycle: Continuous.

### Coil Data @ 20°C

OMIT-L Sensitive				
Rated Coil Voltage (VDC)	Nominal Current (mA)	Coil Resistance (ohms) ± 10%	Must Operate Voltage (VDC)	Must Release Voltage (VDC)
5	106.4	47	3.75	0.25
6	88.0	68	4.50	0.30
9	58.0	155	6.75	0.45
12	44.4	270	9.00	0.90
24	21.8	1,100	18.00	1.20
48	10.9	4,400	36.00	2.40
OMIT-D Standard				
Rated Coil Voltage (VDC)	Nominal Current (mA)	Coil Resistance (ohms) ± 10%	Must Operate Voltage (VDC)	Must Release Voltage (VDC)
5	138.9	36	3.50	0.25
6	120.0	50	4.20	0.30
9	78.3	115	6.30	0.45
12	60.0	200	8.40	0.90
24	29.3	820	16.80	1.20
48	14.5	3,300	33.60	2.40

### Operate Data

Must Operate Voltage:

OMIT-D: 70% of nominal voltage or less.

OMIT-L: 75% of nominal voltage or less.

Must Release Voltage: 5% of nominal voltage or more.

Operate Time: OMIT-D: 15 ms max.

OMIT-L: 20 ms max.

Release Time: 8 ms max.

### Environmental Data

Temperature Range:

Operating: OMIT-D:

-30°C to +55°C

OMIT-L:

-30°C to +70 °C

Vibration, Mechanical: 10 to 55 Hz., 1.5mm double amplitude

Operational: 10 to 55 Hz., 1.5mm double amplitude.

Shock, Mechanical: 1,000m/s<sup>2</sup> (100G approximately).

Operational: 100m/s<sup>2</sup> (10G approximately).

Operating Humidity: 20 to 85% RH. (Non-condensing).

### Mechanical Data

Termination: Printed circuit terminals.

Enclosure (94V-0 Flammability Ratings):

OMIT-SS: Vented (Flux-tight) plastic cover.

OMIT-SH: Sealed plastic case.

Weight: 0.46 oz (13g) approximately.

**Ordering Information**

Typical Part Number ►

**OMIT -SS -1 12 L M ,300**

**1. Basic Series:**

OMIT = Miniature Sealed PC Board Relay

**2. Enclosure:**

SS = Vent (Flux-tight)\* plastic cover.  
SH = Sealed, plastic case.

**3. Termination:**

1 = 1 pole

**4. Coil Voltage:**

05 = 5VDC      09 = 9VDC      24 = 24VDC  
06 = 6VDC      12 = 12VDC      48 = 48VDC

**5. Coil Input:**

D = Standard (720mW)      L = Sensitive (540mW)

**6. Contact Arrangement:**

Blank = 1 Form C, SPDT      M = 1 Form A, SPST-NO

**7. Suffix:**

,300 = Standard model for "SS" enclosure      ,394 = Standard model for "SH" enclosure      Other Suffix = Custom model

\* Not suitable for immersion cleaning processes.

**Our authorized distributors are more likely to maintain the following items in stock for immediate delivery.**

None at present.

**Outline Dimensions**

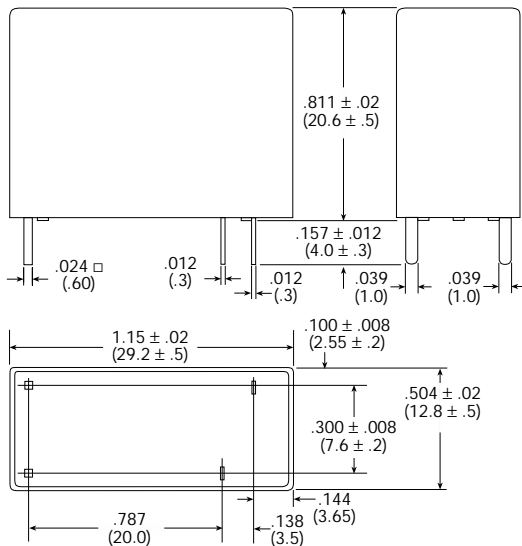

**Wiring Diagram (Bottom View)**



**PC Board Layout (Bottom View)**

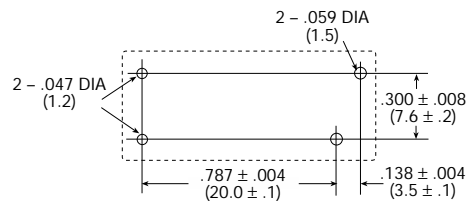

**Reference Data**

**Coil Temperature Rise**

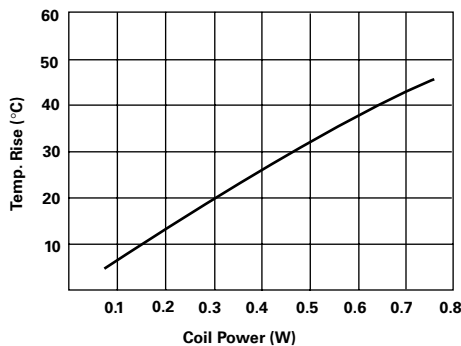

**Operate Time**

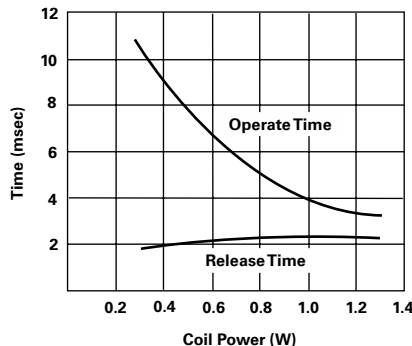

**Life Expectancy**

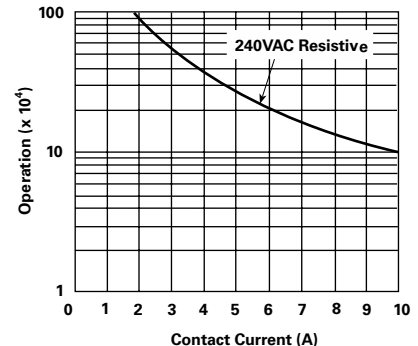

Dimensions are shown for reference purposes only.

Dimensions are in inches over (millimeters) unless otherwise specified.

Specifications and availability subject to change.

www.tycoelectronics.com  
Technical support:  
Refer to inside back cover.



# OMIF series

## 20A Miniature Power PC Board Relay

Appliances, HVAC, Office Machines.

UL File No. E82292

CSA File No. LR48471

VDE File No. 6031

TUV File No. R85447

Users should thoroughly review the technical data before selecting a product part number. It is recommended that user also seek out the pertinent approvals files of the agencies/laboratories and review them to ensure the product meets the requirements for a given application.

### Features

- Meet UL 508, CSA, VDE0435 and TUV requirements.
- 1 Form A contact arrangements.
- Quick Connect Terminal type.
- Meet 5,000V dielectric voltage between coil and contacts.
- Meet 10,000V surge voltage between coil and contacts (1.2 / 50µs).

### Contact Data @ 20°C

**Arrangements:** 1 Form A.

**Material:** AgSnO

**Max. Switching Rate:** 300 ops./min. (no load).  
30 ops./min. (rated load).

**Expected Mechanical Life:** 10 million operations (no load).

**Expected Electrical Life:** 100,000 operations (rated load).

**Minimum Load:** 100mA @ 5VDC.

**Initial Contact Resistance:** 100 milliohms @ 1A, 6VDC.

### Contact Ratings

**Ratings:** 20A @ 125VAC resistive.  
16A @ 250VAC resistive,  
16A @ 24VDC resistive.

**Max. Switched Voltage:** AC: 250V.  
DC: 24V.

**Max. Switched Current:** 20A.

**Max. Switched Power:** 4,000VA, 385W.

### Initial Dielectric Strength

**Between Open Contacts:** 1,000VAC 50/60 Hz. (1 minute).

**Between Coil and Contacts:** 5,000VAC 50/60 Hz. (1 minute).

**Surge Voltage Between Coil and Contacts:** 10,000V (1.2 / 50µs).

### Initial Insulation Resistance

**Between Mutually Insulated Elements:** 1,000M ohms min. @ 500VDC.

### Coil Data

**Voltage:** 12 to 24VDC.

**Nominal Power:** 540mW.

**Coil Temperature Rise:** 35°C max., at rated coil voltage.

**Max. Coil Power:** 130% of nominal.

**Duty Cycle:** Continuous.

### Coil Data @ 20°C

OMIF				
Rated Coil Voltage (VDC)	Nominal Current (mA)	Coil Resistance (ohms) ± 10%	Must Operate Voltage (VDC)	Must Release Voltage (VDC)
12	44.4	270	9.00	0.60
18	30.0	600	13.50	0.90
24	21.8	1,100	18.00	1.20

### Operate Data

**Must Operate Voltage:** 75% of nominal voltage or less.

**Must Release Voltage:** 5% of nominal voltage or more.

**Operate Time:** 20 ms max.

**Release Time:** 10 ms max.

### Environmental Data

**Temperature Range:**

**Operating:** -30°C to +70°C

**Vibration, Mechanical:** 10 to 55 Hz., 1.5mm double amplitude

**Operational:** 10 to 55 Hz., 1.5mm double amplitude.

**Shock, Mechanical:** 1,000m/s<sup>2</sup> (100G approximately).

**Operational:** 100m/s<sup>2</sup> (10G approximately).

**Operating Humidity:** 20 to 85% RH. (Non-condensing).

### Mechanical Data

**Termination:** Printed circuit terminals with quick connect terminals.

**Enclosure (94V-0 Flammability Ratings):**

OMIF-S: Vented (Flux-tight) plastic cover.

**Weight:** 0.53 oz (15g) approximately.

**Ordering Information**

<b>Typical Part Number</b> ▶	<b>OMIF</b>	<b>-S</b>	<b>-1</b>	<b>24</b>	<b>L</b>	<b>M</b>	<b>,300</b>
<b>1. Basic Series:</b> OMIF = 20A PC Board Terminals							
<b>2. Enclosure:</b> S = Vented (Flux-tight)* plastic cover							
<b>3. Termination:</b> 1 = 1 pole							
<b>4. Coil Voltage:</b> 12 = 12VDC      18 = 18VDC      24 = 24VDC							
<b>5. Coil Input:</b> L = Sensitive (540mW)							
<b>6. Contact Arrangement:</b> M = 1 Form A, SPST-NO							
<b>7. Suffix:</b> ,300 = Standard model      Other Suffix = Custom model							

\* Not suitable for immersion cleaning processes.

**Our authorized distributors are more likely to stock the following items for immediate delivery.**

None at present.

**Outline Dimensions**

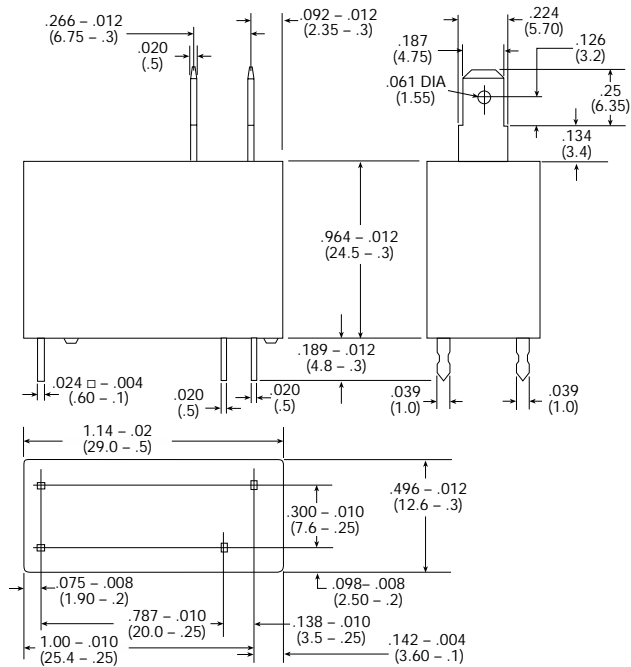

**Wiring Diagram**

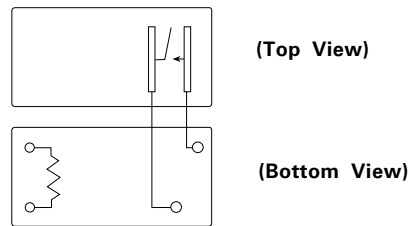

**PC Board Layout (Bottom View)**

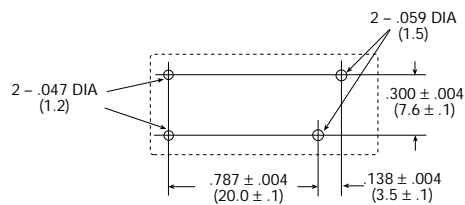

**Reference Data**

**Operating Voltage**

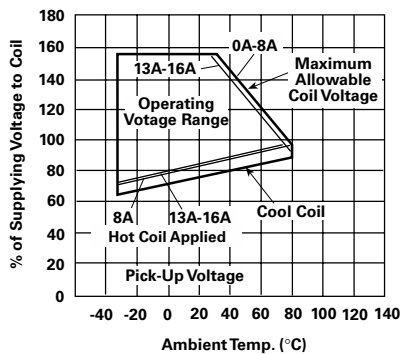

**Note:** This data is based on the max. allowable temperature for E type insulation coil (115°C).

**Operate Time**

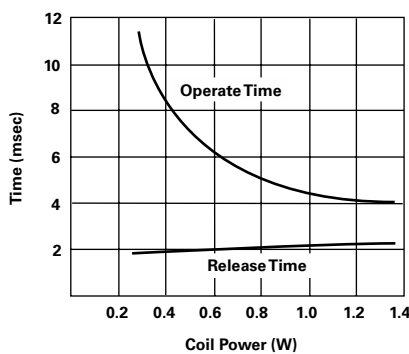

**Life Expectancy**

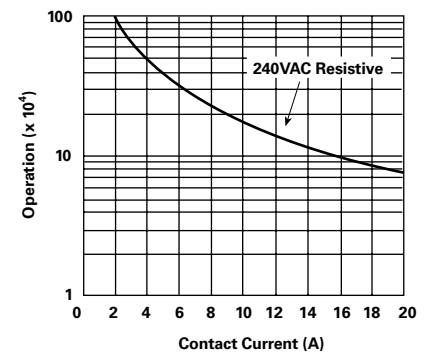

Dimensions are shown for reference purposes only.

Dimensions are in inches over (millimeters) unless otherwise specified.

Specifications and availability subject to change.

www.tycoelectronics.com  
Technical support:  
Refer to inside back cover.



# PCI series

## Slim 2 Form A Miniature PC Board Relay

Appliances, Audio Equipment, Office Machines

UL File No. E82292

CSA File No. LR48471

Users should thoroughly review the technical data before selecting a product part number. It is recommended that user also seek out the pertinent approvals files of the agencies/laboratories and review them to ensure the product meets the requirements for a given application.

### Features

- Slim and simple architecture.
- 2 Form A (DPST-NO) contact arrangement.
- Cadmium-free contacts.
- UL, CSA, approvals.
- Immersion cleanable, sealed version available.
- Magnetic blow-out available for DC loads.

### Contact Data @ 20°C

**Arrangements:** 2 Form A (DPST-NO).

**Material:** Ag-GS Alloy.

**Max. Switching Rate:** 300ops./ min. (no load).  
30ops./ min. (rated load).

**Expected Mechanical Life:** 1 million ops (no load).

**Expected Electrical Life:** 100,000 ops (rated load).

**Minimum Load:** 1mA @ 1VDC.

**Initial Contact Resistance:** 50 milliohms @ 1mA, 6VDC.

### Contact Ratings

**Ratings:** 3A @ 24VDC resistive.  
3A @ 120VAC resistive.

**Max. Switched Voltage:** AC: 240V.  
DC: 50V.

**Max. Switched Current:** 5A.

**Max. Switched Power:** 300VA, 90W.

### Initial Dielectric Strength

**Between Open Contacts:** 1,000VAC, 50/60 Hz. (1 min.).

**Between Adjacent Contacts:** 2,000VAC, 50/60 Hz (1 min).

**Between Contacts and Coil:** 4,000VAC, 50/60 Hz. (1 min.).

**Surge Voltage Between Coil and Contacts:** 7,000V (1.2/50μs).

### Initial Insulation Resistance

**Between Mutually Insulated Conductors:** 1,000Mohm @ 500VDCM.

### Coil Data

**Voltage:** 5 to 48VDC.

**Duty Cycle:** Continuous.

**Nominal Power:** 350mW.

**Max. Coil Power:** 130% of nominal at 20°C.

### Coil Data @ 20°C

PCI				
Rated Coil Voltage (VDC)	Nominal Current (mA)	Coil Resistance (ohms) ± 10%	Must Operate Voltage (VDC)	Must Release Voltage (VDC)
5	69.4	72	3.50	0.50
6	58.8	102	4.20	0.60
9	39.1	230	6.30	0.90
12	29.1	413	8.40	1.20
24	14.5	1,650	16.80	2.40

### Operate Data @ 20°C

**Must Operate Voltage:** 70% of nominal voltage or less.

**Must Release Voltage:** 10% of nominal voltage or more.

**Operate Time :** 15ms max.

**Release Time :** 5ms max.

### Environmental Data

**Temperature Range:**

**Operating:** -30°C to +70°C.

**Vibration, Mechanical:** 10 to 55Hz., 1.5mm double amplitude.

**Operational:** 10 to 55Hz., 1.5mm double amplitude.

**Shock, Mechanical:** 1,000m/s<sup>2</sup> (100G approximately).

**Operational:** 100m/s<sup>2</sup> (10G approximately).

**Operating Humidity:** 20 to 85% RH. (Non-condensing).

### Mechanical Data

**Termination:** Printed circuit terminals.

**Enclosure:** Plastic sealed case with enclosure option "H".

Otherwise, vented (flux-tight) cover.

**Weight:** 0.41 oz (10.5g) approximately.

Typical Part Number ►

PCI -2 05 D M ,000

**1. Basic Series:**  
PCI = Miniature relay

**2. Termination:**  
2 = 2 pole

**3. Coil Voltage:**  
05 = 5VDC    09 = 9VDC    24 = 24VDC  
06 = 6VDC    12 = 12VDC    48 = 48VDC

**4. Coil Input:**  
D = Standard

**5. Contact Arrangement:**  
M = 2 Form A

**6. Enclosure:**  
Blank = Vented (Flux-tight) cover    H = Sealed plastic case

**7. Optional:**  
Blank = Standard    M = with magnetic blow-out

**8. Suffix:**  
,000 = Standard model    Other Suffix = Custom model

**Our authorized distributors are more likely to maintain the following items in stock for immediate delivery.**

None at present.

**Wiring Diagram (Bottom View)**

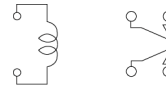
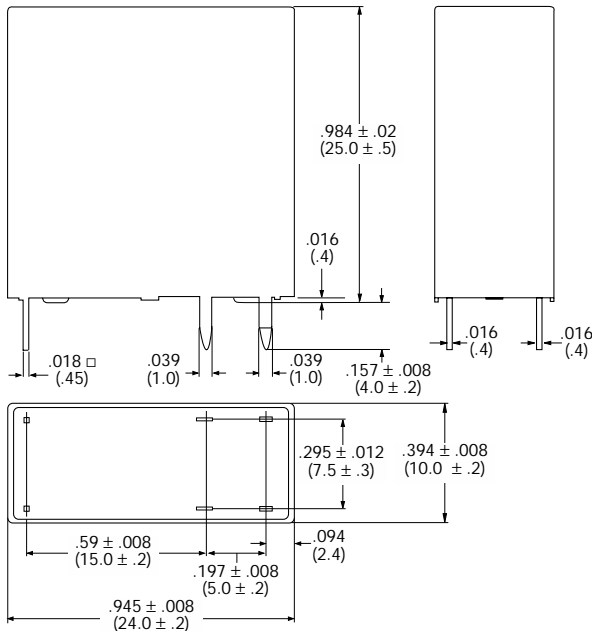

**PC Board Layout (Bottom View)**

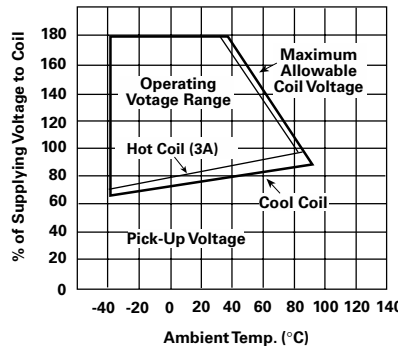
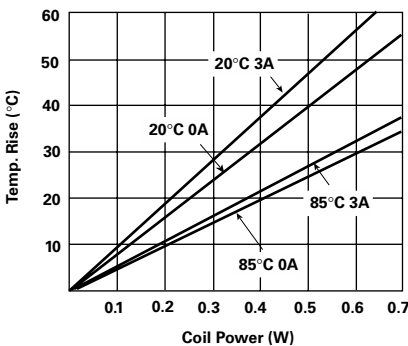
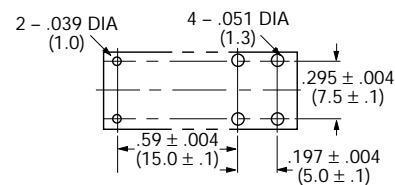

**DC Cut Ability for Audio Speaker Loads**

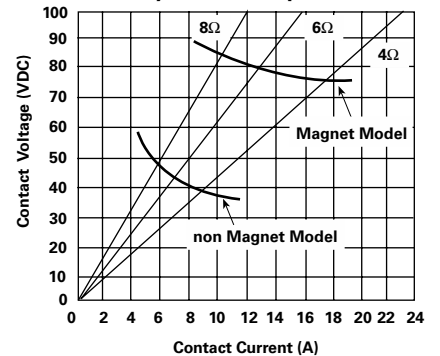

Note: This data is based on the max. allowable temperature for E type insulation coil (115°C).

Dimensions are shown for reference purposes only.

Dimensions are in inches over (millimeters) unless otherwise specified.

Specifications and availability subject to change.

www.tycoelectronics.com  
Technical support:  
Refer to inside back cover.

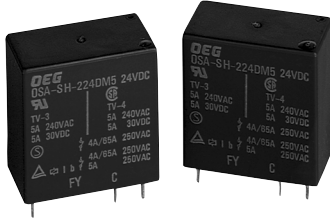

# OSA series

## 2 Pole Miniature Power PC Board Relay

Appliances, Audio Equipment, Office Machines

- UL File No. E82292
- CSA File No. LR48471
- SEMKO File No. 9452086 (available for DM5)
- TUV File No. R9551879 (available for DM5)

Users should thoroughly review the technical data before selecting a product part number. It is recommended that user also seek out the pertinent approvals files of the agencies/laboratories and review them to ensure the product meets the requirements for a given application.

### Features

- Meet UL TV-3 and CSA TV-4 rating available for DM5 type.
- 2 Form A contact arrangements.
- Immersion cleanable, sealed version available.
- Meet 3,000V dielectric voltage between coil and contacts.
- Meet 5,000V surge voltage between coil and contacts (1.2 / 50µs).

### Contact Data @ 20°C

- Arrangements:** 2 Form A (DPST-NO).  
**Material:** Ag-GS Alloy (DM3) and AgSnO (DM5).  
**Max. Switching Rate:** 300 ops./min. (no load).  
 30 ops./min. (rated load).  
**Expected Mechanical Life:** 10 million operations (no load).  
**Expected Electrical Life:** 100,000 operations (rated load).  
**Minimum Load:**  
 OSA-DM3: 1mA @ 1VDC.  
 OSA-DM5: 100mA @ 5VDC.  
**Initial Contact Resistance:** 50 milliohms @ 1A, 6VDC.

### Contact Ratings

- Ratings:** OSA-DM3: 3A @ 120VAC resistive,  
 3A @ 24VDC resistive,  
 OSA-DM5: 5A @ 240VAC resistive,  
 5A @ 30VDC resistive,  
 TV-3 @ 120VAC Tungsten (UL),  
 TV-4 @ 120VAC Tungsten (CSA).  
**Max. Switched Voltage:**  
 OSA-DM3: AC: 240V. DC: 50V.  
 OSA-DM5: AC: 250V. DC: 30V.  
**Max. Switched Current:** 5A  
**Max. Switched Power:**  
 OSA-DM3: 300VA.  
 OSA-DM5: 1,100VA.

### Initial Dielectric Strength

- Between Open Contacts:** 1,000VAC 50/60 Hz. (1 minute).  
**Between Coil and Contacts:** 3,000VAC 50/60 Hz. (1 minute).  
**Surge Voltage Between Coil and Contacts:** 5,000V (1.2 / 50µs).

### Initial Insulation Resistance

- Between Mutually Insulated Elements:** 1,000M ohms min. @ 500VDC.

### Coil Data

- Voltage:** 5 to 48VDC.  
**Nominal Power:** 540 mW  
**Coil Temperature Rise:** 50°C max., at rated coil voltage.  
**Max. Coil Power:** 130% of nominal.  
**Duty Cycle:** Continuous.

### Coil Data @ 20°C

OSA				
Rated Coil Voltage (VDC)	Nominal Current (mA)	Coil Resistance (ohms) ± 10%	Must Operate Voltage (VDC)	Must Release Voltage (VDC)
5	106.4	47	3.75	0.50
6	88.0	68	4.50	0.60
9	58.0	155	6.75	0.90
12	44.4	270	9.00	1.20
24	21.8	1,100	18.00	2.40
48	11.0	4,400	36.00	4.80

### Operate Data

- Must Operate Voltage:** 75% of nominal voltage or less.  
**Must Release Voltage:** 10% of nominal voltage or more.  
**Operate Time:** 20 ms max.  
**Release Time:** 10 ms max.

### Environmental Data

- Temperature Range:**  
**Operating:** -30°C to +60°C  
**Vibration, Mechanical:** 10 to 55 Hz., 1.5mm double amplitude  
**Operational:** 10 to 55 Hz., 1.5mm double amplitude.  
**Shock, Mechanical:** 1,000m/s<sup>2</sup> (100G approximately).  
**Operational:** 100m/s<sup>2</sup> (10G approximately).  
**Operating Humidity:** 20 to 85% RH. (Non-condensing).

### Mechanical Data

- Termination:** Printed circuit terminals.  
**Enclosure (94V-0 Flammability Ratings):**  
 OSA-SS: Vented (Flux-tight) plastic cover.  
 OSA-SH: Sealed plastic case.  
**Weight:** 0.46 oz (13g) approximately.

**Ordering Information**

Typical Part Number ▶

**OSA -SS -2 24 D M 3 ,000**

**1. Basic Series:**

OSA = Miniature Power PC board relay.

**2. Enclosure:**

SS = Vent (Flux-tight)\* plastic cover.  
SH = Sealed, plastic case.

**3. Termination:**

2 = 2 pole

**4. Coil Voltage:**

05 = 5VDC      09 = 9VDC      24 = 24VDC  
06 = 6VDC      12 = 12VDC      48 = 48VDC

**5. Coil Input:**

D = Standard

**6. Contact Arrangement:**

M = 2 Form A, DPST-NO

**7. Contact Rating:**

3 = 3A @ 120VAC resistive (DM3).      5 = 5A @ 240VAC resistive (DM5).

**8. Suffix:**

,000 = Standard model      Other Suffix = Custom model

\* Not suitable for immersion cleaning processes.

**Our authorized distributors are more likely to maintain the following items in stock for immediate delivery.**

None at present.

**Outline Dimensions**

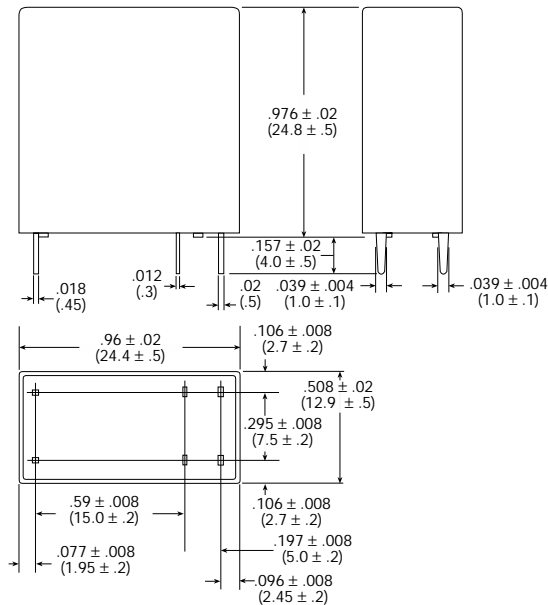

**Wiring Diagram (Bottom View)**

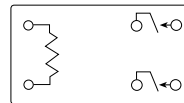

**PC Board Layout (Bottom View)**

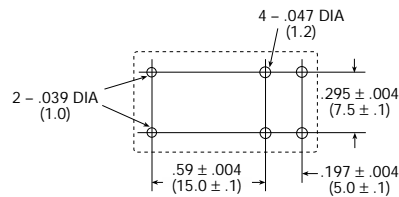

**Reference Data**

**Coil Temperature Rise**

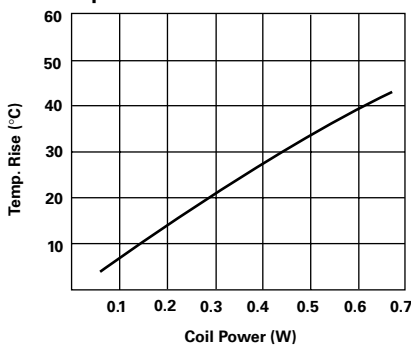

**Operate Time**

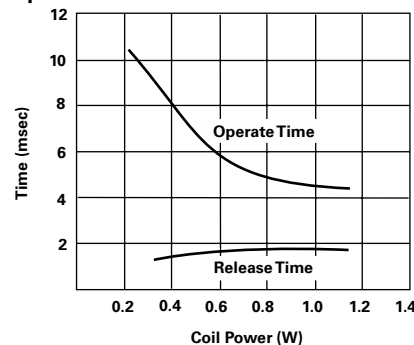

**Life Expectancy**

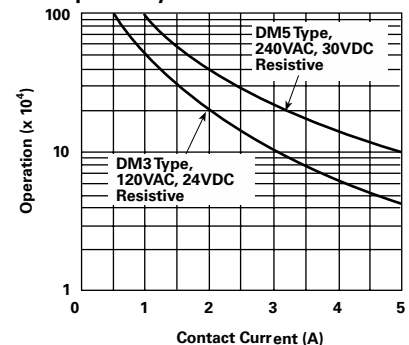

Dimensions are shown for reference purposes only.

Dimensions are in inches over (millimeters) unless otherwise specified.

Specifications and availability subject to change.

www.tycoelectronics.com  
Technical support:  
Refer to inside back cover.



# OSZ series

## 1 Pole Miniature Power PC Board Relay

Appliances, HVAC, Office Machines

UL File No. E58304

CSA File No. LR48471

Users should thoroughly review the technical data before selecting a product part number. It is recommended that user also seek out the pertinent approvals files of the agencies/laboratories and review them to ensure the product meets the requirements for a given application.

### Features

- Meet UL Tungsten TV-8 rating.
- 1 Form A contact arrangements.
- Immersion cleanable, sealed version available.
- Meet 4,000V dielectric voltage between coil and contacts.
- Meet 7,000V surge voltage between coil and contacts (1.2 / 50μs).

### Contact Data @ 20°C

**Arrangements:** 1 Form A (SPST-NO).

**Material:** AgSnO.

**Max. Switching Rate:** 300 ops./min. (no load).  
30 ops./min. (rated load).

**Expected Mechanical Life:** 10 million operations (no load).

**Expected Electrical Life:** 100,000 operations (rated load).

**Minimum Load:** 100mA @ 5VDC.

**Initial Contact Resistance:** 100 milliohms @ 1A, 6VDC.

### Contact Ratings

**Ratings:** 16A @ 240VAC resistive,  
16A @ 24VDC resistive,  
TV-8 @ 120VAC Tungsten, 25,000ops.

**Max. Switched Voltage:** **AC:** 240V.  
**DC:** 24V.

**Max. Switched Current:** 16A.

**Max. Switched Power:** 2,400VA, 380W.

### Initial Dielectric Strength

**Between Open Contacts:** 1,000VAC 50/60 Hz. (1 minute).

**Between Coil and Contacts:** 4,000VAC 50/60 Hz. (1 minute).

**Surge Voltage Between Coil and Contacts:** 7,000V (1.2 / 50μs).

### Initial Insulation Resistance

**Between Mutually Insulated Elements:** 1,000M ohms min. @ 500VDC.

### Coil Data

**Voltage:** 5 to 48VDC.

**Nominal Power:** 540 mW

**Coil Temperature Rise:** 55°C max., at rated coil voltage.

**Max. Coil Power:** 130% of nominal.

**Duty Cycle:** Continuous.

### Coil Data @ 20°C

OSZ				
Rated Coil Voltage (VDC)	Nominal Current (mA)	Coil Resistance (ohms) ± 10%	Must Operate Voltage (VDC)	Must Release Voltage (VDC)
5	106.4	47	3.75	0.25
6	88.0	68	4.50	0.30
9	58.0	155	6.75	0.45
12	44.4	270	9.00	0.60
24	21.8	1,100	18.00	1.20
48	11.0	4,400	36.00	2.40

### Operate Data

**Must Operate Voltage:** 75% of nominal voltage or less.

**Must Release Voltage:** 5% of nominal voltage or more.

**Operate Time:** 20 ms max.

**Release Time:** 10 ms max.

### Environmental Data

**Temperature Range:**

**Operating:** -30°C to +65°C

**Vibration, Mechanical:** 10 to 55 Hz., 1.5mm double amplitude

**Operational:** 10 to 55 Hz., 1.5mm double amplitude.

**Shock, Mechanical:** 1,000m/s<sup>2</sup> (100G approximately).

**Operational:** 100m/s<sup>2</sup> (10G approximately).

**Operating Humidity:** 20 to 85% RH. (Non-condensing).

### Mechanical Data

**Termination:** Printed circuit terminals.

**Enclosure (94V-0 Flammability Ratings):**

**OSZ-SS:** Vented (Flux-tight) plastic cover.

**OSZ-SH:** Sealed plastic case.

**Weight:** 0.45 (13g) approximately.

**Ordering Information**

Typical Part Number ►

**OSZ -SS -1 12 D M 8 ,000**

**1. Basic Series:**

OSZ = Miniature Power PC board relay.

**2. Enclosure:**

SS = Vent (Flux-tight)\* plastic cover.  
SH = Sealed, plastic case.

**3. Termination:**

1 = 1 pole

**4. Coil Voltage:**

05 = 5VDC      09 = 9VDC      24 = 24VDC  
06 = 6VDC      12 = 12VDC      48 = 48VDC

**5. Coil Input:**

D = Standard

**6. Contact Arrangement:**

M = 1 Form A, SPST-NO.

**7. Contact Rating:**

8 = TV-8 rating

**8. Suffix:**

,000 = Standard model      Other Suffix = Custom model

\* Not suitable for immersion cleaning processes.

**Our authorized distributors are more likely to maintain the following items in stock for immediate delivery.**

None at present.

**Outline Dimensions**

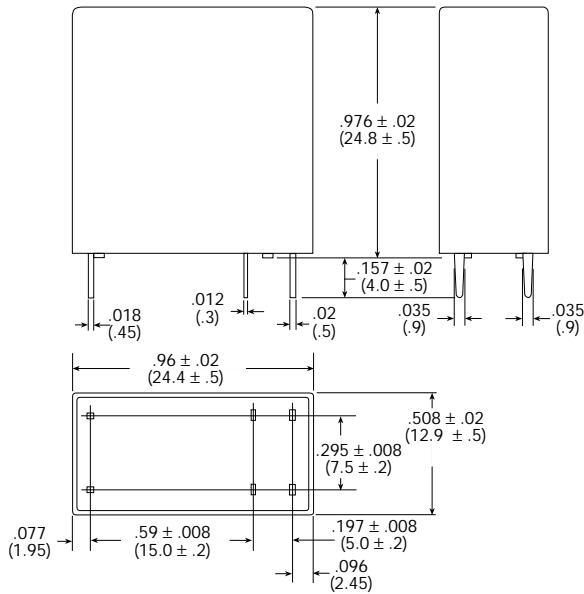

**Wiring Diagram (Bottom View)**

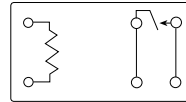

**PC Board Layout (Bottom View)**

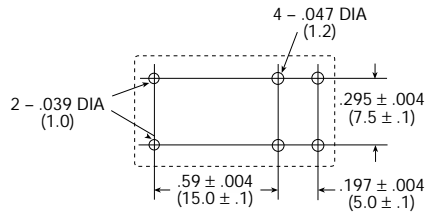

**Reference Data**

**Coil Temperature Rise**

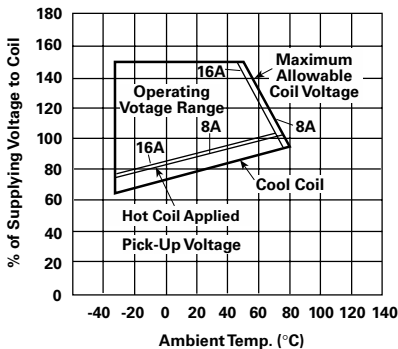

**Operate Time**

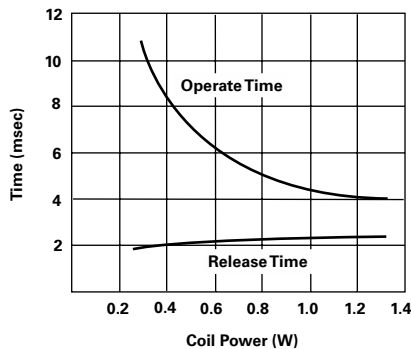

**Life Expectancy**

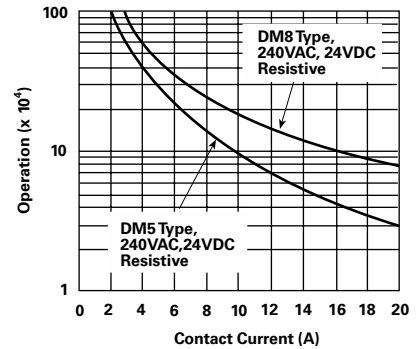

Note: This data is based on the max. allowable temperature for E type insulation coil (115°C).

Dimensions are shown for reference purposes only.

Dimensions are in inches over (millimeters) unless otherwise specified.

Specifications and availability subject to change.

www.tycoelectronics.com  
 Technical support:  
 Refer to inside back cover.

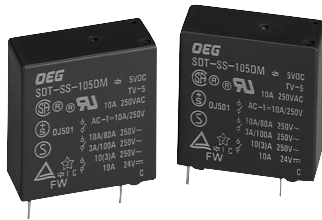

# SDT series

## 10 Amp Miniature Power PC Board Relay

Appliances, HVAC, CTV, Monitor Display

- UL File No. E82292
- CSA File No. LR48471
- SEMKO File No. 9308008
- TUV File No. R9551731
- SEV File No. 97550375

Users should thoroughly review the technical data before selecting a product part number. It is recommended that user also seek out the pertinent approvals files of the agencies/laboratories and review them to ensure the product meets the requirements for a given application.

### Features

- UL TV-5 rating relay.
- 1 Form A contact arrangement.
- Immersion cleanable, sealed version available.
- Applications include appliance, HVAC, CTV, monitor, emergency lighting.

### Contact Data @ 20°C

**Arrangements:** 1 Form A (SPST-NO)

**Material:** AgSnO.

**Max. Switching Rate:** 300 ops./min. (no load).  
30 ops./min. (rated load).

**Expected Mechanical Life:** 10 million operations (no load).

**Expected Electrical Life:** 100,000 operations (rated load).

**Minimum Load:** 100mA @ 5VDC.

**Initial Contact Resistance:** 100 milliohms @ 1A, 6VDC.

### Contact Ratings

**Ratings:** 5A Tungsten @ 120VAC (TV-5) 25,000ops.  
10A @ 250VAC resistive,  
10A @ 120VAC resistive,  
10A @ 30VDC resistive.

3A @ 250VAC inductive (cos $\phi$ = 0.4),  
3A @ 30VDC inductive (L/R=7msec).

**Max. Switched Voltage:** AC: 250V.  
DC: 30V.

**Max. Switched Current:** 10A.

**Max. Switched Power:** 2,500VA, 300W.

### Initial Dielectric Strength

**Between Open Contacts:** 900VAC 50/60 Hz. (1 minute).

**Between Coil and Contacts:** 4,000VAC 50/60 Hz. (1 minute).

**Surge Voltage Between Coil and Contacts:** 10,000V (1.2 / 50 $\mu$ s).

### Initial Insulation Resistance

**Between Mutually Insulated Elements:** 1,000M ohms min. @ 500VDCM.

### Coil Data

**Voltage:** 5 to 48VDC.

**Nominal Power:** 540 mW

**Coil Temperature Rise:** 40°C max., at rated coil voltage.

**Max. Coil Power:** 130% of nominal.

**Duty Cycle:** Continuous.

### Coil Data @ 20°C

SDT				
Rated Coil Voltage (VDC)	Nominal Current (mA)	Coil Resistance (ohms) $\pm$ 10%	Must Operate Voltage (VDC)	Must Release Voltage (VDC)
5	106.4	47	3.75	0.50
6	88.0	68	4.50	0.60
9	58.0	155	6.75	0.90
12	44.4	270	9.00	1.20
24	21.8	1,100	18.00	2.40
48	10.9	4,400	36.00	4.80

### Operate Data

**Must Operate Voltage:** 75% of nominal voltage or less.

**Must Release Voltage:** 10% of nominal voltage or more.

**Operate Time:** 15 ms max.

**Release Time:** 8 ms max.

### Environmental Data

**Temperature Range:**

**Operating:** -30°C to +70°C

**Vibration, Mechanical:** 10 to 55 Hz., 1.5mm double amplitude

**Operational:** 10 to 55 Hz., 1.5mm double amplitude.

**Shock, Mechanical:** 1,000m/s<sup>2</sup> (100G approximately).

**Operational:** 100m/s<sup>2</sup> (10G approximately).

**Operating Humidity:** 20 to 85% RH. (Non-condensing).

### Mechanical Data

**Termination:** Printed circuit terminals.

**Enclosure (94V-0 Flammability Ratings):**

**SDT-SS:** Vented (Flux-tight) plastic cover

**SDT-SH:** Sealed plastic case

**Weight:** 0.39 oz (11g) approximately.

**Ordering Information**

Typical Part Number ▶

**SDT**

**-SS**

**-1**

**12**

**D**

**M**

**,000**

**1. Basic Series:**

SDT = Miniature Power PC board relay.

**2. Enclosure:**

SS = Vented (Flux-tight) \* plastic cover.  
SH = Sealed, plastic case.

**3. Termination:**

1 = 1 pole

**4. Coil Voltage:**

05 = 5VDC      09 = 9VDC      24 = 24VDC  
06 = 6VDC      12 = 12VDC      48 = 48VDC

**5. Coil Input:**

D = Standard

**6. Contact Arrangement:**

M = 1 Form A, SPST-NO

**7. Suffix:**

,000 = Standard model      Other Suffix = Custom model

\* Not suitable for immersion cleaning processes.

**Our authorized distributors are more likely to maintain the following items in stock for immediate delivery.**

None at present.

**Outline Dimensions**

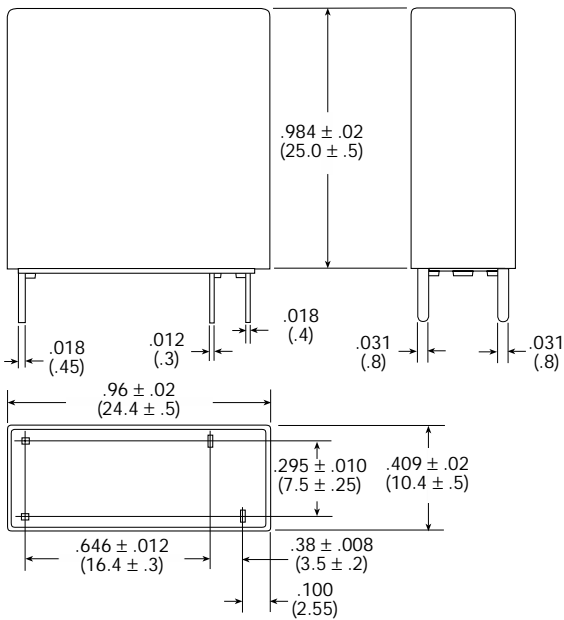

**Wiring Diagram (Bottom View)**

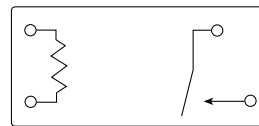

**PC Board Layout (Bottom View)**

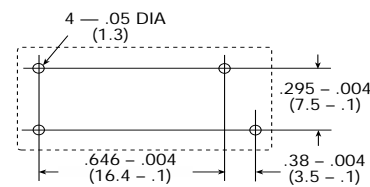

**Reference Data**

**Operating Voltage**

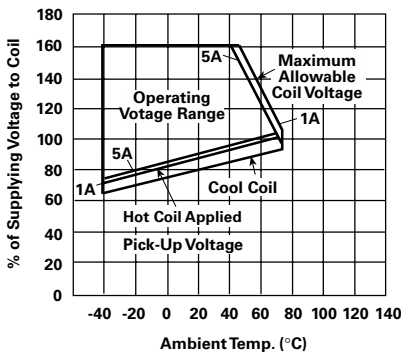

**Note:** This data is based on the max. allowable temperature for E type insulation coil (115°C).

**Operate Time**

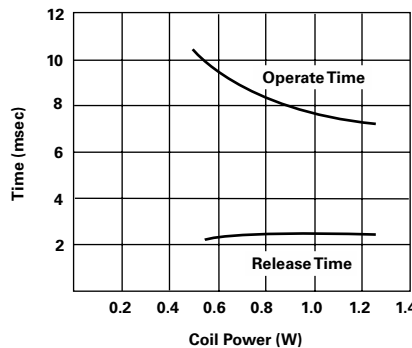

**Life Expectancy**

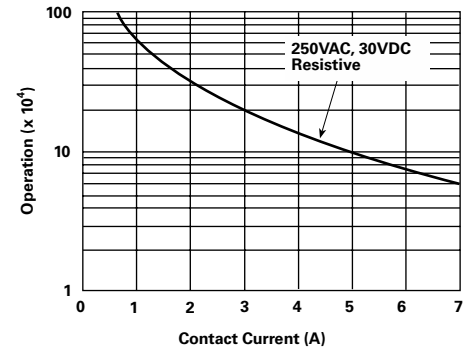



# SDT-R series

## 10 Amp Miniature Power PC Board Relay

Appliances, HVAC, CTV, Monitor Display.

- UL File No. E58304
- CSA File No. LR48471
- SEMKO FileNo. 9722134, 9803052
- TUV File No. R9750487

Users should thoroughly review the technical data before selecting a product part number. It is recommended that user also seek out the pertinent approvals files of the agencies/laboratories and review them to ensure the product meets the requirements for a given application.

### Features

- UL TV-5 and TV-8 rating relay.
- 1 Form A contact arrangement.
- Sensitive and standard coils available.
- Applications include appliance, HVAC, CTV, Monitor, emergency lighting.

### Contact Data @ 20°C

**Arrangements:** 1 Form A (SPST-NO)

**Material:** AgSnO

**Max. Switching Rate:** 300 ops./min. (no load),  
30 ops./min. (rated load).

**Expected Mechanical Life:** 10 million operations (no load).

**Expected Electrical Life:** 100,000 operations (rated load).

**Minimum Load:** 100mA @ 5VDC.

**Initial Contact Resistance:** 100 milliohms @ 1A, 6VDC.

### Contact Ratings

**Ratings:**

**SDT-LMR:** 5A Tungsten @ 120VAC (TV-5) 25,000ops.  
5A @ 250VAC resistive,  
5A @ 30VDC resistive.

**SDT-DMR:** 8A Tungsten @ 120VAC (TV-8) 25,000ops.  
10A @ 250VAC resistive,  
10A @ 30VDC resistive.

**Max. Switched Voltage:** AC: 250V.  
DC: 30V.

**Max. Switched Current:** 5A (SDT-LMR), 10A (SDT-DMR)

**Max. Switched Power:** 1,250VA, 150W (SDT-LMR),  
2,500VA, 300W (SDT-DMR).

### Initial Dielectric Strength

**Between Open Contacts:** 1,000VAC 50/60 Hz. (1 minute).

**Between Coil and Contacts:** 4,000VAC 50/60 Hz. (1 minute).

**Surge Voltage Between Coil and Contacts:** 10,000V (1.2 / 50µs).

### Initial Insulation Resistance

**Between Mutually Insulated Elements:** 1,000M ohms min. @ 500VDCM.

### Coil Data

**Voltage:** 5 to 48VDC.

**Nominal Power:**

SDT-LMR : 250 mW

SDT-DMR : 540 mW

**Coil Temperature Rise:** 40°C max., at rated coil voltage.

**Max. Coil Power:** 130% of nominal.

**Duty Cycle:** Continuous.

### Coil Data @ 20°C

SDT-LMR (250mW)				
Rated Coil Voltage (VDC)	Nominal Current (mA)	Coil Resistance (ohms) ± 10%	Must Operate Voltage (VDC)	Must Release Voltage (VDC)
5	50.0	100	3.75	0.50
6	41.7	144	4.50	0.60
9	27.7	325	6.75	0.90
12	20.7	580	9.00	1.20
24	10.5	2,300	18.00	2.40
SDT-DMR (400mW)				
Rated Coil Voltage (VDC)	Nominal Current (mA)	Coil Resistance (ohms) ± 10%	Must Operate Voltage (VDC)	Must Release Voltage (VDC)
5	106.4	47	3.75	0.50
6	88.0	68	4.50	0.60
9	58.0	155	6.75	0.90
12	44.4	270	9.00	1.20
24	21.8	1,100	18.00	2.40
48	10.9	4,400	36.00	4.80

### Operate Data

**Must Operate Voltage:** 75% of nominal voltage or less.

**Must Release Voltage:** 10% of nominal voltage or more.

**Operate Time:** 15 ms max.

**Release Time:** 5 ms max.

### Environmental Data

**Temperature Range:**

**Operating:** -30°C to +70°C

**Vibration, Mechanical:** 10 to 55 Hz., 1.5mm double amplitude

**Operational:** 10 to 55 Hz., 1.5mm double amplitude.

**Shock, Mechanical:** 1,000m/s<sup>2</sup> (10G approximately).

**Operational:** 100m/s<sup>2</sup> (10G approximately).

**Operating Humidity:** 20 to 85% RH. (Non-condensing).

### Mechanical Data

**Termination:** Printed circuit terminals.

**Enclosure (94V-0 Flammability Ratings):**

**SDT-S:** Snap-on dust cover (Flux-tight).

**Weight:** 0.38 oz. (11g) approximately.

**Ordering Information**

<b>Typical Part Number ▶</b>	<b>SDT</b>	<b>-S</b>	<b>-1</b>	<b>12</b>	<b>L</b>	<b>M</b>	<b>R</b>	<b>,000</b>
<p><b>1. Basic Series:</b> SDT = Miniature Power PC board relay.</p> <p><b>2. Enclosure:</b> S = Snap-on (Flux-tight)* cover.</p> <p><b>3. Termination:</b> 1 = 1 pole</p> <p><b>4. Coil Voltage:</b> 05 = 5VDC      09 = 9VDC      24 = 24VDC 06 = 6VDC      12 = 12VDC      48 = 48VDC</p> <p><b>5. Coil Input:</b> L = Sensitive (250mW)      D = Standard (540mW)</p> <p><b>6. Contact Arrangement:</b> M = 1 Form A, SPST-NO</p> <p><b>7. Construction:</b> R = New construction</p> <p><b>8. Suffix:</b> ,000 = Standard model      Other Suffix = Custom model</p>								

\* Not suitable for immersion cleaning processes.

**Our authorized distributors are more likely to maintain the following items in stock for immediate delivery.**

None at present.

**Outline Dimensions**

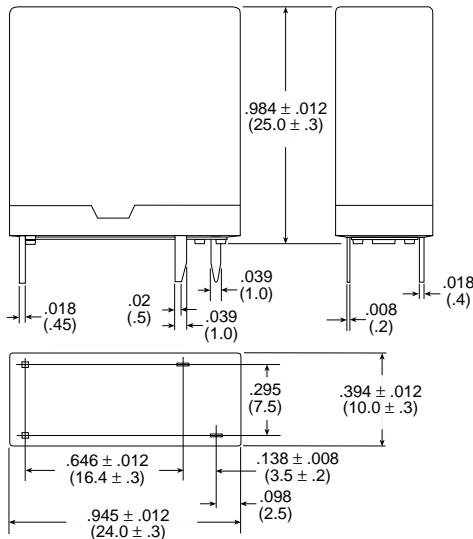

**Wiring Diagram (Bottom View)**

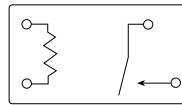

**PC Board Layout (Bottom View)**

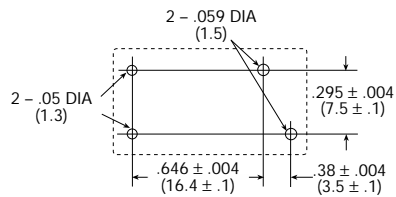

**Reference Data**

**Operating Voltage (SDT-LMR)**

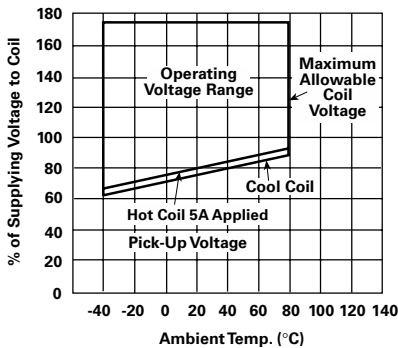

**Note:** This data is based on the max. allowable temperature for E type insulation coil (115°C).

**Operate Time**

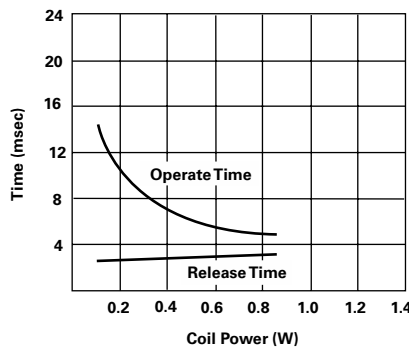

**Life Expectancy**

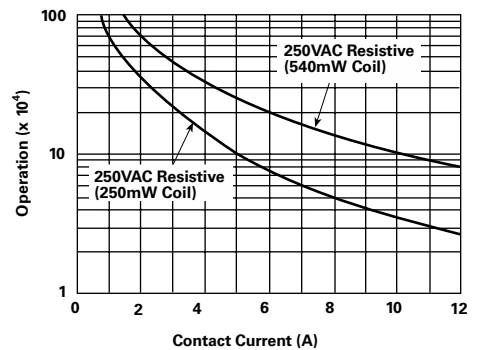

# PCK series

## Slim 16 Amp Miniature Power PC Board Relay

Appliances, HVAC, Office Machines.

UL File No. E82292

CSA File No. LR48471



Users should thoroughly review the technical data before selecting a product part number. It is recommended that user also seek out the pertinent approvals files of the agencies/laboratories and review them to ensure the product meets the requirements for a given application.

### Features

- Slim outline to save board space.
- 1 Form A contact arrangement.
- Quick connect terminal type.
- Meet 5,000V dielectric voltage between coil and contacts.
- Meet 10,000V surge voltage between coil and contacts.

### Contact Data @ 20°C

**Arrangements:** 1 Form A (SPST-NO) .

**Material:** AgSnO.

**Max. Switching Rate:** 300ops./ min. (no load).  
20ops./ min. (rated load).

**Expected Mechanical Life:** 2 million ops (no load).

**Expected Electrical Life:** 100,000 ops (rated load).

**Minimum Load:** 100mA @ 5VDC.

**Initial Contact Resistance:** 100 milliohms @ 1A, 6VDC.

### Coil Data @ 20°C

PCK				
Rated Coil Voltage (VDC)	Nominal Current (mA)	Coil Resistance (ohms) ± 10%	Must Operate Voltage (VDC)	Must Release Voltage (VDC)
5	100.0	50.0	3.75	0.25
6	83.3	72.0	4.50	0.30
9	55.6	162.0	6.75	0.45
12	41.7	288.0	9.00	0.60
18	27.8	648.0	13.50	0.90
24	20.9	1,150.0	18.00	1.20

### Contact Ratings

**Ratings:** 16A @ 250VAC resistive.

16A @ 24VDC resistive.

**Max. Switched Voltage:** AC: 277V.

DC: 24V.

**Max. Switched Current:** 16A.

**Max. Switched Power:** 4,000VA, 385W.

### Initial Dielectric Strength

**Between Open Contacts:** 1,000VAC, 50/60 Hz. (1 min.).

**Between Contacts and Coil:** 5,000VAC, 50/60 Hz. (1 min.).

**Surge Voltage Between Coil and Contacts:** 10,000V (1.2/50µs).

### Initial Insulation Resistance

**Between Mutually Insulated Conductors:** 1,000Mohm @ 500VDC.

### Coil Data

**Voltage:** 5 to 24VDC.

**Duty Cycle:** Continuous.

**Nominal Power:** 500mW.

**Max. Coil Power:** 130% of nominal at 20°C.

### Operate Data @ 20°C

**Must Operate Voltage:** 75% of nominal voltage or less.

**Must Release Voltage:** 5% of nominal voltage or more.

**Operate Time:** 20ms max.

**Release Time:** 10ms max.

### Environmental Data

**Temperature Range:**

**Operating:** -30°C to +70°C.

**Vibration, Mechanical:** 10 to 55Hz., 1.5mm double amplitude.

**Operational:** 10 to 55Hz., 1.5mm double amplitude.

**Shock, Mechanical:** 1000m/s<sup>2</sup> (100G approximately).

**Operational:** 100m/s<sup>2</sup> (10G approximately).

**Operating Humidity:** 20 to 85% RH. (Non-condensing).

### Mechanical Data

**Termination:** Printed circuit terminals with quick connect terminals.

**Enclosure:** Vented (Flux-tight) plastic cover.

**Weight:** 0.46 oz (13g) approximately.

**Ordering Information**

Typical Part Number ►

**PCK -1 12 D 2 M ,000**

**1. Basic Series:**

PCK = 16A PC board terminals

**2. Termination:**

1 = 1 pole

**3. Coil Voltage:**

05 = 5VDC      09 = 9VDC      18 = 18VDC  
06 = 06VDC      12 = 12VDC      24 = 24VDC

**4. Coil Input:**

D = Standard

**5. Contact Material:**

2 = AgSnO

**6. Contact Arrangement:**

M = 1 Form A (SPST-NO)

**7. Suffix:**

,000 = Standard model

Other Suffix = Custom model

**Our authorized distributors are more likely to maintain the following items in stock for immediate delivery.**

None at present.

**Outline Dimensions**

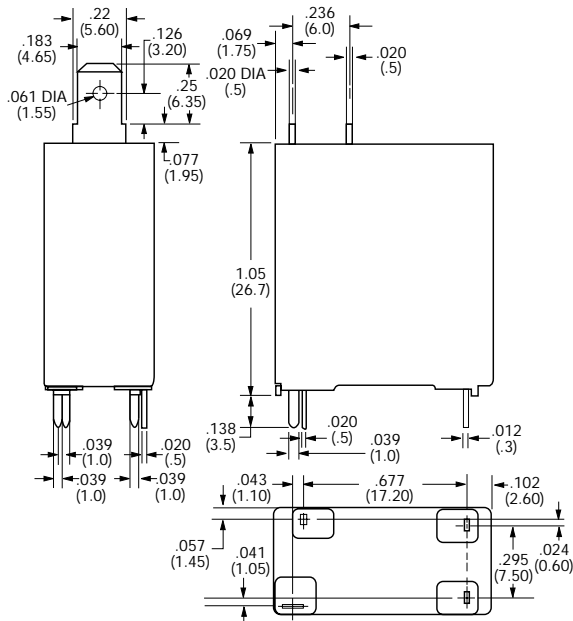

**Wiring Diagram (Bottom View)**

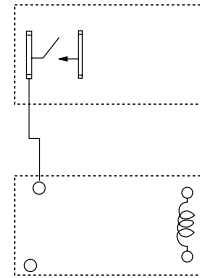

**PC Board Layout (Bottom View)**

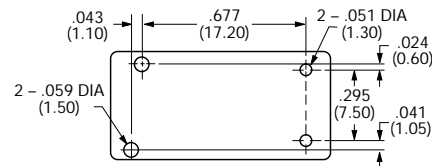

**Reference Data**

**Coil Temperature Rise**

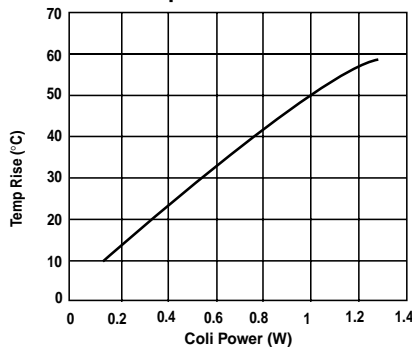

**Operate Time**

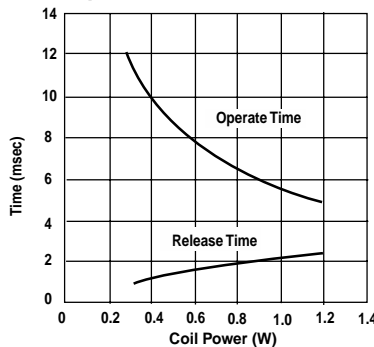

**Life Expectancy**

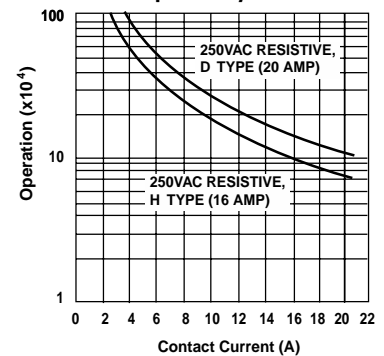

Dimensions are shown for reference purposes only.

Dimensions are in inches over (millimeters) unless otherwise specified.

Specifications and availability subject to change.

www.tycoelectronics.com  
Technical support:  
Refer to inside back cover.



# V23057 (Card E) series

## 8 Amp, Miniature Printed Circuit Board Relay

UL File E214025  
UL

Users should thoroughly review the technical data before selecting a product part number. It is recommended that users also seek out the pertinent approvals files of the agencies/laboratories and review them to ensure the product meets the requirements for a given application.

### Features

- 1 Form A (SPST-NO) and 1 Form C (SPDT).
- 8 amp rated current.
- Vertical or horizontal version.
- Single or bifurcated contacts.
- 4,000Vrms contact-to-coil dielectric.
- Washable (sealed) plastic case.

### Contact Data

**Arrangements:** 1 Form A (SPST-NO) and 1 Form C (SPDT), single or bifurcated contact.

**Material:** Silver-nickel 0.15, silver-nickel 20 or silver-cadmium oxide.

**Expected Mechanical Life:** 20 million operations.

#### Ratings:

**Current:** 8A; 5A with silver-nickel 0.15 contacts.

**Voltage:** 250VAC.

**Power (breaking):** 2,000 VA.

**Voltage (breaking):** 440VAC.

**Current (making, max. 4s at 10% duty cycle):** 15A.

#### Silver-nickel 0.15

4 amp resistive, 30VDC, 2 million ops

1 amp inductive L / R = 40 ms, 24VDC, 200,000 ops.

#### Silver-cadmium oxide

1 amp cosj = 0.4, 230VAC, 500,000 ops.

### Mechanical Data

**Termination:** Printed circuit terminals.

**Enclosure (94 V-0 rated):** Sealed (RTIII) plastic case.

**Weight:** 0.28 oz. (8 g) approximately.

### Contact Life

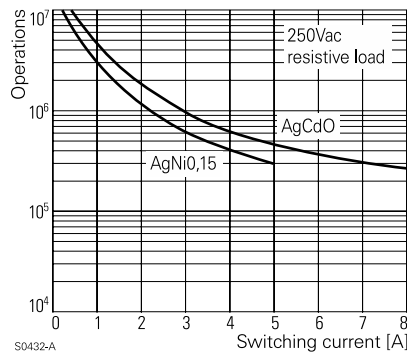

### Initial Dielectric Strength

**Between Open Contacts:** 1,000Vrms.

**Between Coil and Contacts:** 4,000Vrms.

**Creepage/Clearance:** 4/4mm.

### Coil Data DC @ 20°C

**Nominal Coil Power:** 450 - 500mW, dependent upon model.

Nominal Voltage VDC	DC Resistance in Ohms	Must Operate Voltage VDC	Drop-out Voltage VDC	Maximum Voltage VDC	Nominal Coil Current (mA)
6	80 ±10%	4.0	0.6	10.6	75.0
12	330 ±10%	8.0	1.2	21.5	36.4
24	1,200 ±15%	16.0	2.4	40.0	20.0
48	4,700 ±15%	32.0	4.8	79.0	10.2
60	7,200 ±15%	40.0	6.0	98.0	8.3

### Operate Data

**Must Operate Voltage:** See Coil Data table.

**Operate Time:** 7 ms.

**Release Time:** 3 ms.

**Bounce Time (N/O contact / N/C contact):** 0.5 ms / 3 ms.

**Switching Rate:** 3,600 ops./hr. max. at rated load.

### Environmental Data

**Temperature Range:**

**Operating:** -40°C to +70°C.

### Max. DC Load Breaking Capacity

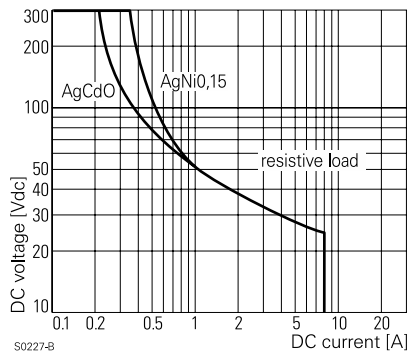

### Coil Operating Range

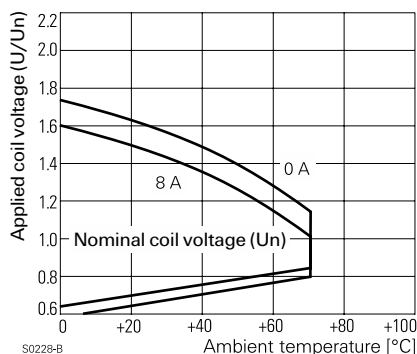

**Ordering Information**

Typical Part Number ▶

**V23057 -A 0 006 -A 1 01**

**1. Basic Series:**

V23057 = Card E miniature printed circuit board relay.

**2. Mounting Orientation:**

A = Horizontal. B = Vertical.

**3. Version:**

0 = Standard

**4. Coil Voltage:**

001 = 6VDC 002 = 12VDC 006 = 24VDC 013 = 48VDC 023 = 60VDC

**5. Contact Type:**

A = Single contact. B = Bifurcated contact (Not available on 1 Form A version).

**6. Contact Material:**

1 = Silver-nickel 0.15 2 = Silver-nickel 20 4 = Silver-cadmium oxide

**7. Contact Arrangement:**

01 = 1 Form C (SPDT) 02 = 1 Form A (SPST-NO)

**Our authorized distributors are more likely to stock the following items for immediate delivery.**

None at present.

**Outline Dimensions**

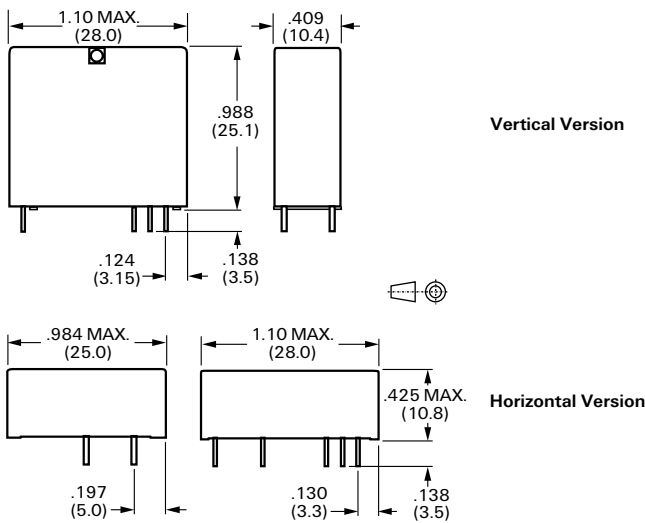

**Wiring Diagrams (Bottom Views)**

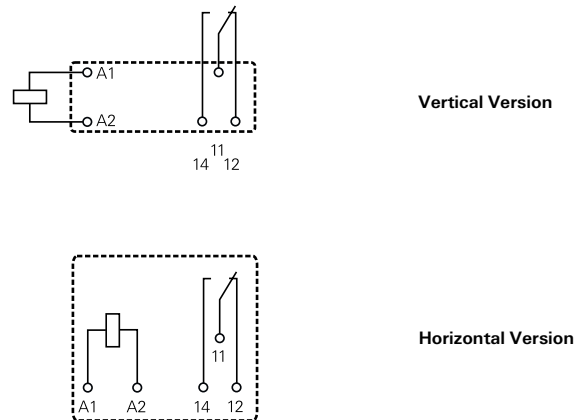

**PC Board Layouts (Bottom Views)**

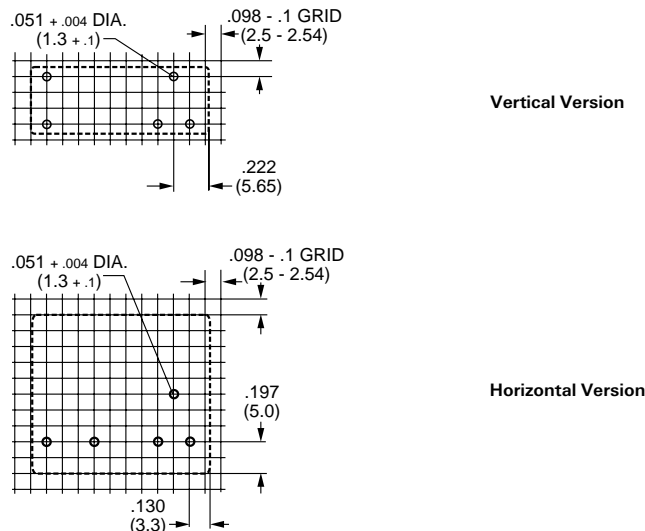



# RP II/2 series

## 8 Amp, 2 Pole PC Board Relay

UL File E214025



Users should thoroughly review the technical data before selecting a product part number. It is recommended that users also seek out the pertinent approvals files of the agencies/laboratories and review them to ensure the product meets the requirements for a given application.

### Features

- 2 Form A (DPST-NO) or 2 Form C (DPDT).
- 8 amp rating with terminals on 5 mm pin spacing.
- 4kV/8mm contact-to-coil.
- Sockets available.

### Environmental Data

**Temperature Range:**  
**Operating:** -40°C to +70°C.  
**Vibration (30-150 Hz.):** N/O: 11g; N/C: 1.5g.  
**Shock (destructive):** 100g.

### Contact Data

**Arrangements:** 2 Form A (DPST-NO) and 2 Form C (DPDT), single contact.  
**Material:** Silver-cadmium oxide or silver-nickel 0.15.  
**Expected Mechanical Life:** 20 million operations.

#### Ratings:

**Current:** 8A (UL: 10A)  
**Voltage:** 250VAC  
**Power (breaking):** 2,000VA  
**Voltage (breaking):** 440VAC  
**Make Current (max. 4s at 10% duty cycle):** 14A

#### Load/Life

Type	Load	Life (Ops.)
RP440	64A ON, 2A OFF, 250VAC	10,000
RP421	2A, 50VDC, resistive	2 million
RP421	1/10 HP, 240VAC, per contact	UL 508
RP421	3A, 380VAC, AC11	30,000
RP421	0.18A, 110VDC, DC11	100,000
RP420	0.6A, 220VAC, $\cos\phi = 0.8$ , single phase motor	1.3 million

### Mechanical Data

**Termination:** Printed circuit terminals.  
**Enclosure:** Flux-tight (RT II) plastic case or sealed (RT III) cover.  
**Weight:** .63 oz. (18 g) approximately.

### Contact Life

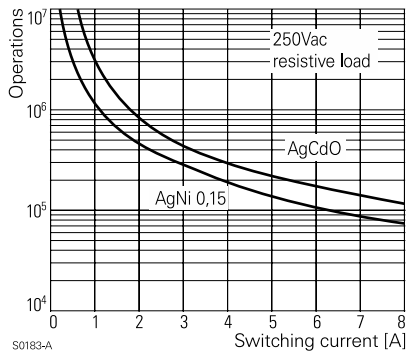

### Max. DC Load Breaking Capacity

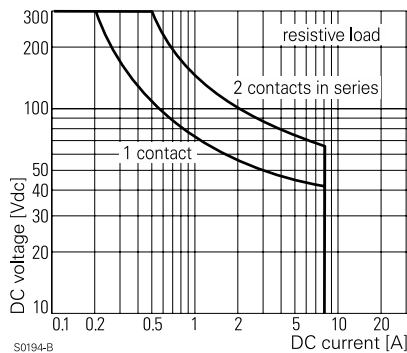

### Initial Dielectric Strength

**Between Open Contacts:** 1,000Vrms  
**Between Coil and Contacts:** 4,000Vrms.  
**Between Contact Sets:** 2,500Vrms.  
**Creepage/Clearance:** 8/8mm.

### Coil Data DC @ 20°C

**Nominal Coil Power:** 500mW.

Nominal Voltage VDC	DC Resistance in Ohms	Must Operate Voltage VDC	Drop-out Voltage VDC	Maximum Voltage VDC	Nominal Coil Current (mA)
5	54 ± 10%	3.5	0.5	9.0	92.6
6	68 ± 10%	4.2	0.6	10.8	88.2
12	270 ± 10%	8.4	1.2	21.6	44.4
24	1,100 ± 15%	16.8	2.4	43.2	21.8
48	4,400 ± 15%	33.6	4.8	86.4	10.9
60	6,540 ± 15%	42.0	6.0	108.0	9.2
110	23,100 ± 15%	77.0	11.0	198.0	4.8

### Operate Data

**Must Operate Voltage:** See Coil Data table.  
**Operate Time (typical):** 9 ms.  
**Release Time (typical):** 3 ms.  
**Bounce Time (typical):** N/O: 2 ms; N/C: 3 ms.  
**Switching Rate:** 6,000 ops./hr. max. at rated load.

### Coil Operating Range

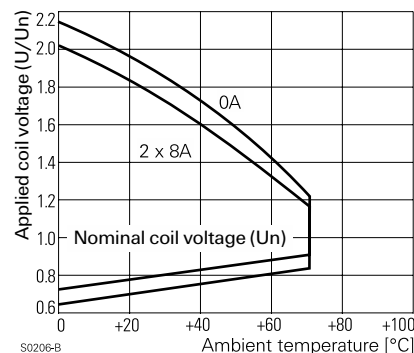

**Ordering Information**

Typical Part Number ▶

**RP 4 1 0 012**

**1. Basic Series:**

RP = Printed circuit board relay.

**2. Version:**

4 = 8A, flux-tight. 8 = 8A, sealed.

**3. Contact Arrangement:**

2 = 2 Form C (DPDT). 4 = 2 Form A (DPST-NO).

**4. Contact Material and Pin Spacing:**

0 = Silver-cadmium oxide, 5 mm pin spacing.  
1 = Silver-nickel 0.15, 5 mm pin spacing.

**5. Coil Voltage:**

005 = 5VDC      012 = 12VDC      048 = 48VDC      110 = 110VDC  
006 = 6VDC      024 = 24VDC      060 = 60VDC

**Our authorized distributors are more likely to maintain the following items in stock for immediate delivery.**

None at present.

**Outline Dimensions**

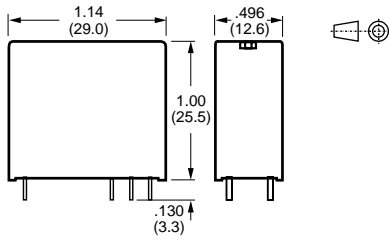

**Wiring Diagrams (Bottom Views)**

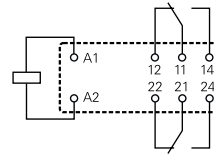

**2 Form C**

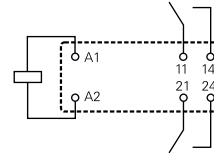

**2 Form A**

**PC Board Layout (Bottom View)**

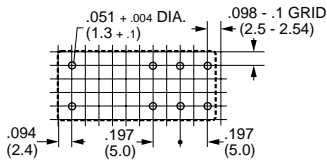



# RP II/1 series

## 8-16 Amp, 1 Pole PC Board Relay

UL File E214025



12A Version Only

Users should thoroughly review the technical data before selecting a product part number. It is recommended that users also seek out the pertinent approvals files of the agencies/laboratories and review them to ensure the product meets the requirements for a given application.

### Features

- 1 Form A (SPST-NO) or 1 Form C (SPDT).
- 8 and 12 amp models available with 3.5 or 5mm pin spacing.
- 16 amp models available with 5mm pin spacing.
- 4kV/8mm contact-to-coil.
- Sockets available.

### Environmental Data

**Temperature Range:**

**Operating:** -40°C to +70°C.

**Vibration (30-300 Hz.):** N/O: >10g; N/C: 2g.

**Shock (destructive):** 100g.

### Contact Data

**Arrangements:** 1 Form A (SPST-NO) and 1 Form C (SPDT), single contact.

**Material:** Silver-cadmium oxide or silver-nickel 0.15.

**Expected Mechanical Life:** 30 million operations.

#### Ratings:

	8A	12A	16A
<b>Current:</b>	8A	12A	16A
<b>Voltage:</b>	250VAC	250VAC	250VAC
<b>Power (breaking):</b>	2,000VA	3,000VA	4,000VA
<b>Voltage (breaking):</b>	400VAC	400VAC	400VAC
<b>Make Current:</b>	16A	20A	25A
<b>Material:</b>	AgNi 0.15	AgCdO	AgCdO

#### Load/Life

Type	Load	Life (Ops.)
RP410	12A, 250VAC, $\cos\phi = 1$ , 1200/h, 40% duty cycle	110,000
RP410	9.1A, 220VAC, $\cos\phi = 1$ , 360/h, 15% duty cycle	200,000
RP418	3.4A ON, 0.42A OFF, 220VAC, $\cos\phi = 0.6$	> 1.1 million
RP411	8A, 250VAC, $\cos\phi = 1$ , 50% duty cycle	100,000
RP412	8A, 250VAC, $\cos\phi = 1$ , 50% duty cycle	100,000
RP330	18.2A, 250VAC, $\cos\phi = 1$ , 600/h, 15% duty cycle	110,000
RP330	96A ON, 16A OFF, 250VAC, $\cos\phi = 0.6$ , 450/h	>30,000

### Mechanical Data

**Termination:** Printed circuit terminals.

**Enclosure:** Flux-tight (RT II) plastic case or sealed (RT III) cover.

**Weight:** .63 oz. (18 g) approximately.

### Contact Life

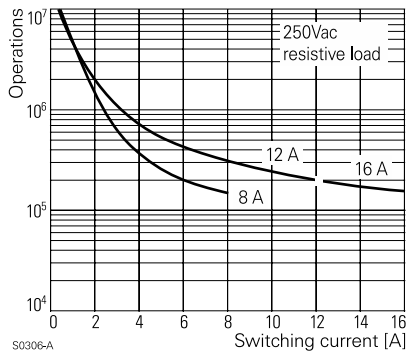

### Max. DC Load Breaking Capacity

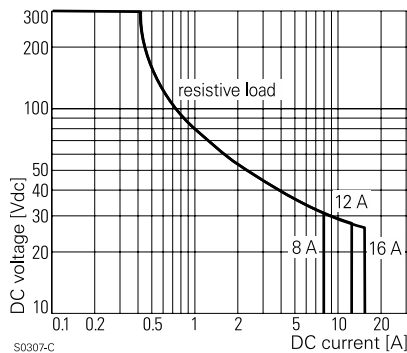

### Initial Dielectric Strength

**Between Open Contacts:** 1,000Vrms

**Between Coil and Contacts:** 4,000Vrms.

**Creepage/Clearance:** 8/8mm.

### Coil Data DC @ 20°C

**Nominal Coil Power:** 500mW.

Nominal Voltage VDC	DC Resistance in Ohms	Must Operate Voltage VDC	Drop-out Voltage VDC	Maximum Voltage VDC	Nominal Coil Current (mA)
5	54 ± 10%	3.5	0.5	9.0	92.6
6	68 ± 10%	4.2	0.6	10.8	88.2
12	270 ± 10%	8.4	1.2	21.6	44.4
24	1,100 ± 15%	16.8	2.4	43.2	21.8
48	4,400 ± 15%	33.6	4.8	86.4	10.9
60	6,540 ± 15%	42.0	6.0	108.0	9.2
110	23,100 ± 15%	77.0	11.0	198.0	4.8

### Operate Data

**Must Operate Voltage:** See Coil Data table.

**Operate Time (typical):** 8 ms.

**Release Time (typical):** 2 ms.

**Bounce Time (typical):** N/O: 2 ms; N/C: 4 ms.

**Switching Rate:** 6,000 ops./hr. max. at rated load.

### Coil Operating Range

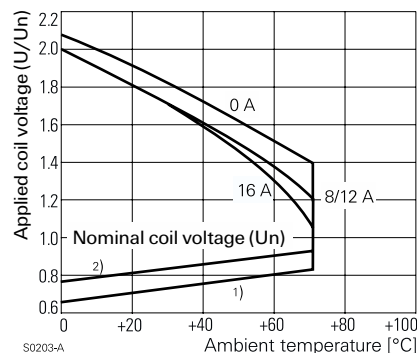

**Ordering Information**

<b>Typical Part Number ▶</b>				<b>RP</b>	<b>4</b>	<b>1</b>	<b>0</b>	<b>012</b>
<b>1. Basic Series:</b> RP = Printed circuit board relay.								
<b>2. Version:</b> 3 = 16A, flux tight.    4 = 8/12A, flux-tight.    7 = 16A, sealed.    8 = 8/12A, sealed.								
<b>3. Contact Arrangement:</b> 1 = 1 Form C (SPDT).    3 = 1 Form A (SPST-NO).								
<b>4. Contact Material and Pin Spacing:</b> 0 = Silver-cadmium oxide, 16A or 12A, 5 mm pin spacing.    2 = Silver-nickel 0.15, 8A, 3.5 mm pin spacing. 1 = Silver-nickel 0.15, 8A, 5 mm pin spacing.    8 = Silver-cadmium oxide, 12A, 3.5 mm pin spacing.								
<b>5. Coil Voltage:</b> 005 = 5VDC    012 = 12VDC    048 = 48VDC    110 = 110VDC 006 = 6VDC    024 = 24VDC    060 = 60VDC								

**Our authorized distributors are more likely to maintain the following items in stock for immediate delivery.**

None at present.

**Outline Dimensions**

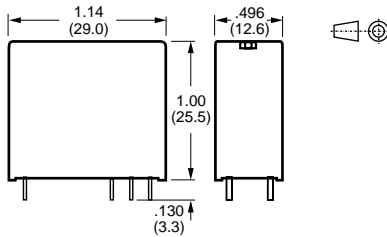

**PC Board Layouts (Bottom Views)**

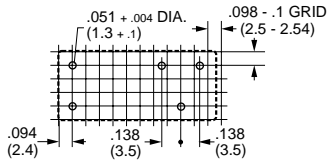

**8/12A, 3.5 mm Pin Spacing**

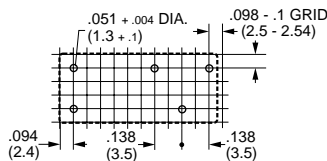

**8/12A, 5 mm Pin Spacing**

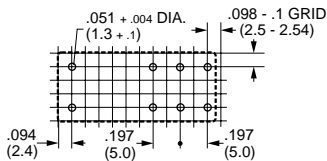

**16A, 5 mm Pin Spacing**

**Wiring Diagrams (Bottom Views)**

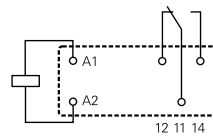

**1 Form C, 8/12A, 3.5 mm**

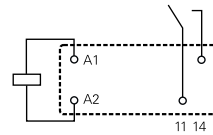

**1 Form A, 8/12A, 3.5 mm**

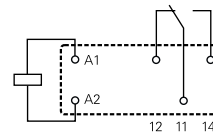

**1 Form C, 8/12A, 5 mm**

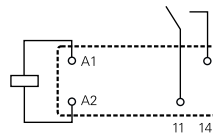

**1 Form A, 8/12A, 5 mm**

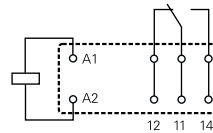

**1 Form C, 16A, 5 mm**

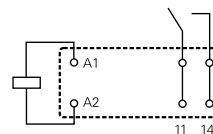

**1 Form A, 16A, 5 mm**



# RP 3 SL series

## 16 Amp, 1 Pole PC Board Relay for High Inrush Loads

US File E214025



Users should thoroughly review the technical data before selecting a product part number. It is recommended that users also seek out the pertinent approvals files of the agencies/laboratories and review them to ensure the product meets the requirements for a given application.

### Features

- 1 Form A (SPST-NO).
- 16 amp models handles up to 120A peak inrush current.
- 4kV/8mm contact-to-coil.
- Latching and non-latching types.

### Contact Data

**Arrangements:** 1 Form A (SPST-NO), single contact.

**Material:** Silver-tin oxide.

**Expected Mechanical Life:** 30 million operations.

#### Ratings:

**Current:** 16A

**Voltage:** 250VAC

**Power (breaking):** 4,000VA

**Voltage (breaking):** 440VAC

**Make Current (max 4s at 10% duty cycle):** 25A

**Peak Inrush Current:** 120A

#### Load/Life

12A, 250VAC,  $\cos\phi = 1$ ; 300,000 ops.

TV8; 25,000 ops.

2,500W, 230VAC, Halogen lamps; > 10,000 ops.

1,000W, 250VAC, Incandescent lamps; 230,000 ops.

3,000W, 250VAC, Incandescent lamps; 36,000 ops.

1,500VA, Fluorescent lamps, 163 $\mu$ F; 10,000 ops.

### Initial Dielectric Strength

**Between Open Contacts:** 2,000Vrms

**Between Coil and Contacts:** 4,000Vrms.

**Creepage/Clearance:** 8/8mm.

### Coil Data DC @ 20°C

**Nominal Coil Power:** Non-latching: 500mW.

Single-coil latching: 1.2 - 1.4W.

Dual-coil latching: 1.2 - 1.5W.

Nominal Voltage VDC	DC Resistance in Ohms	Must Operate Voltage VDC	Drop-out Voltage VDC	Maximum Voltage VDC	Nominal Coil Current (mA)
<b>Non-Latching Models</b>					
12	270 $\pm$ 10%	9.0	1.2	21.6	44.4
24	1,100 $\pm$ 15%	18.0	2.4	43.2	21.8
48	4,400 $\pm$ 15%	36.0	4.8	86.4	10.9
60	6,540 $\pm$ 15%	45.0	6.0	108.0	9.2
Nominal Voltage VDC	DC Resistance in Ohms	Must Operate Voltage VDC	Reset Voltage VDC	Reset R1 Ohms / W	Nominal Coil Current (mA)
<b>Single-coil Latching Models – Reset Voltage 70-110% of Nom.</b>					
5	21 $\pm$ 10%	3.7	3.6	39 / 0.5	238.1
12	115 $\pm$ 10%	9.0	8.7	220 / 0.5	104.3
24	460 $\pm$ 10%	18.0	16.7	820 / 0.5	52.2
<b>Dual-coil Latching Models – Reset Voltage 75-120% of Nom.</b>					
12	105 $\pm$ 15%	9.0	9.0	–	114.3
24	460 $\pm$ 15%	18.0	18.0	–	52.2

### Operate Data

**Must Operate Voltage:** See Coil Data table.

**Operate / Release Time (Non-latching, typical):** 8 ms / 2 ms.

**Operate / Reset Time (Latching, typical):** 6 ms / 2 ms.

**Bounce Time (typical):** 2 ms.

**Switching Rate:** 6,000 ops./hr. max. at rated load.

### Environmental Data

**Temperature Range:**

**Operating:** -40°C to +70°C.

**Vibration (30-300 Hz.):** 20g.

**Shock (destructive):** 100g.

### Mechanical Data

**Termination:** Printed circuit terminals.

**Enclosure:** Flux-tight (RT II) plastic case or sealed (RT III) cover.

**Weight:** .63 oz. (18 g) approximately.

### Contact Life

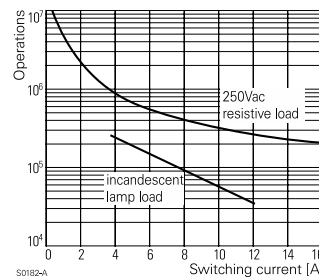

### Max. DC Load Breaking Capacity

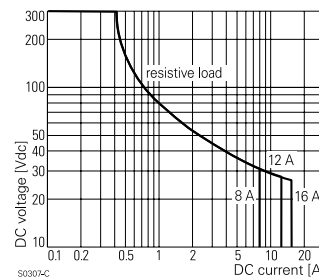

### Coil Operating Range

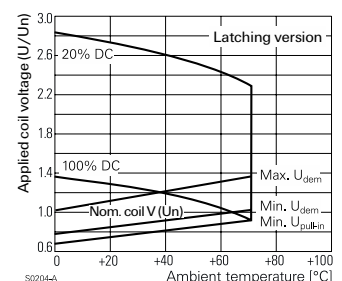
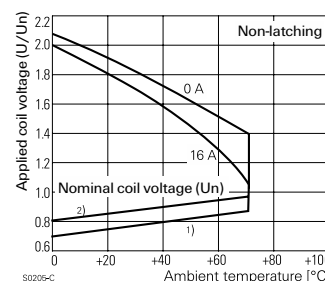

Non-Latching Models

Latching Models

**Ordering Information**

	Typical Part Number ▶	<b>RP</b>	<b>3</b>	<b>SL</b>	<b>F12</b>															
<p><b>1. Basic Series:</b> RP = Printed circuit board relay.</p> <p><b>2. Version:</b> 3 = Flux tight.      7 = Sealed.</p> <p><b>3. Contact Arrangement / Material:</b> SL = 1 Form A (SPST-NO), Silver-tin oxide.</p> <p><b>4. Coil Voltage:</b></p> <table border="0" style="width: 100%;"> <tr> <td>Non-Latching Models:</td> <td>012 = 12VDC</td> <td>024 = 24VDC</td> <td>048 = 48VDC</td> <td>060 = 60VDC</td> </tr> <tr> <td>Single-Coil Latching Models:</td> <td>A05 = 5VDC</td> <td>A12 = 12VDC</td> <td>A24 = 24VDC</td> <td></td> </tr> <tr> <td>Dual-Coil Latching Models:</td> <td>F12 = 12VDC</td> <td>F24 = 24VDC</td> <td></td> <td></td> </tr> </table>						Non-Latching Models:	012 = 12VDC	024 = 24VDC	048 = 48VDC	060 = 60VDC	Single-Coil Latching Models:	A05 = 5VDC	A12 = 12VDC	A24 = 24VDC		Dual-Coil Latching Models:	F12 = 12VDC	F24 = 24VDC		
Non-Latching Models:	012 = 12VDC	024 = 24VDC	048 = 48VDC	060 = 60VDC																
Single-Coil Latching Models:	A05 = 5VDC	A12 = 12VDC	A24 = 24VDC																	
Dual-Coil Latching Models:	F12 = 12VDC	F24 = 24VDC																		

**Our authorized distributors are more likely to maintain the following items in stock for immediate delivery.**

TBD

**Outline Dimensions**

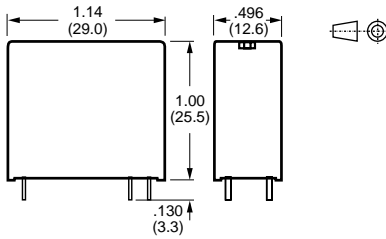

**Wiring Diagram (Bottom View)**

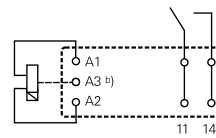

**Latching Versions:**  
Contact position shown results during or after Coil energization with reset voltage.

**Two-Coil Versions:**  
Operate: A2, A3  
Reset A1, A3

**Terminal b) only present on two-coil latching models**

**PC Board Layout (Bottom View)**

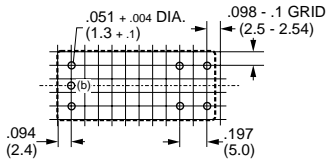

**Circuit Diagram for Single-Coil Latching Model**

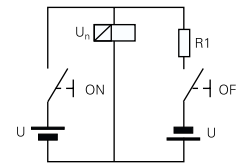

S0329-A



# 0409 series

## High Inrush (500A/10µs) Printed Circuit Board Relay

File E214025

Users should thoroughly review the technical data before selecting a product part number. It is recommended that users also seek out the pertinent approvals files of the agencies/laboratories and review them to ensure the product meets the requirements for a given application.

### Features

- 1 Form A (SPST-NO).
- Tungsten prerun contact and silver-cadmium oxide contact.
- 10 amp rated current, 500A/10µs inrush current.
- 4kV/8mm contact-to-coil, insulation to VDE 0631 and 0700.
- Non-latching and latching types.
- Well suited for lighting systems, motors, lamp loads.

### Contact Data

**Arrangements:** 1 Form A (SPST-NO), single contact.  
**Material:** Tungsten prerun contact and silver-cadmium oxide contact.  
**Expected Mechanical Life:** 30 million operations.

### Ratings:

- Current:** 10A.
- Current (making, max. 4s at 10% duty cycle):** 16A.
- Current (peak inrush 10µs):** 500A.
- Voltage:** 250VAC.
- Voltage (breaking):** 400VAC.

### Load/Life

- 10 amp resistive, 250VAC; 250,000 ops.
- 2,500W, incandescent lamps; 30,000 ops.
- 1,300W, fluorescent lamps (140µF); 30,000 ops.
- 1,000W, Dulux lamps (140µF); 30,000 ops.

### Initial Dielectric Strength

**Between Open Contacts:** 1,000Vrms.  
**Between Coil and Contacts:** 4,000Vrms.  
**Creepage/Clearance:** 8/8mm.

### Non-Latching Coil Data DC @ 20°C

**Nominal Coil Power: Non-latching:** 820mW.

Nominal Voltage VDC	DC Resistance in Ohms ±10%	Must Operate Voltage VDC	Drop-out Voltage VDC	Maximum Voltage VDC	Nominal Coil Current (mA)
6	80	4.2	0.4	12.0	75.0
12	300	8.4	0.9	24.0	40.0
24	1,200	16.8	1.8	48.0	20.0
48	4,825	33.6	3.6	96.0	10.0
60	7,500	42.0	4.5	120.0	8.0

### Latching Coil Data DC @ 20°C

**Nominal Coil Power: Latching:** 0.8 - 1W.  
**Minimum Energization Time:** 20 ms.

Nominal Voltage VDC	DC Resistance in Ohms ±10%	Must Operate Voltage VDC	Min. Reset Voltage VDC	Max. Reset Voltage VDC	Nominal Coil Current (mA)
12	118	8.9	0.7	2.5	40.0
24	457	18.0	1.3	5.0	20.0

### Operate Data

**Must Operate Voltage:** See Coil Data table.  
**Operate Time /Release Time (typical):** 10 ms / 3ms.  
**Bounce Time (typical):** 3 ms.  
**Switching Rate:** 9,000 ops./hr. max. at rated load.

### Environmental Data

**Temperature Range: Operating:** -20°C to +70°C.  
**Vibration (30-300 Hz.):** 20g.  
**Shock (destructive):** 100g.

### Mechanical Data

**Termination:** Printed circuit terminals.  
**Enclosure (94 V-0 rated):** Flux-tight (RTII) plastic case.  
**Weight:** 0.35 oz. (10 g) approximately.

### Coil Operating Range

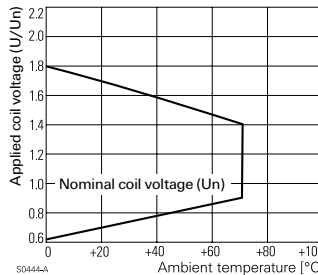

### Ordering Information

Typical Part Number ►

0409

47

031

001

#### 1. Basic Series:

0409 = Miniature printed circuit board relay for high inrush currents.

#### 2. Type:

47 = Non-latching                      67 = Latching

#### 3. Coil Voltage:

Non latching Coil: 031 = 12VDC      027 = 24VDC      024 = 48VDC      023 = 60VDC  
 Latching Coil: 032 = 12VDC      029 = 24VDC

#### 4. Contact Configuration:

001 = 1 Form A (SPST-NO)

**Our authorized distributors are more likely to stock the following items for immediate delivery.**

None at present.

### Outline Dimensions

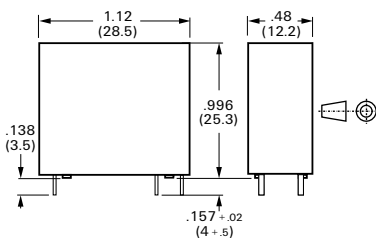

### PC Board Layout (Bottom View)

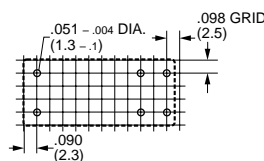

### Wiring Diagram (Bottom View)

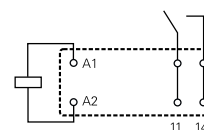



# V23077 (IF) series

## 16 Amp, Miniature Printed Circuit Board Relay

UL File E214025



Users should thoroughly review the technical data before selecting a product part number. It is recommended that users also seek out the pertinent approvals files of the agencies/laboratories and review them to ensure the product meets the requirements for a given application.

### Features

- 1 Form A (SPST-NO) and 1 Form B (SPST-NC).
- 16 amp rated current.
- Quick connect terminals for load.
- Ambient temperature up to 125°C.
- 4kV/8mm contact-to-coil, insulation to VDE 0631 and 0700.
- Flux-tight plastic case.

### Contact Data

**Arrangements:** 1 Form A (SPST-NO) and 1 Form B (SPST-NC), single contact.

**Material:** Silver-cadmium oxide.

**Expected Mechanical Life:** 30 million operations.

#### Ratings:

**Current:** 16A.

**Voltage:** 250VAC.

**Power (breaking):** 4,000 VA.

**Voltage (breaking):** 440VAC.

**Current (making, max. 4s at 10% duty cycle):** 25A.

#### 1 Form A Contacts

10 amp resistive, 400VAC, 125°C, 200,000 ops.

16 amp resistive, 250VAC, 125°C, 100,000 ops.

#### 1 Form B Contacts

10 amp resistive, 400VAC, 125°C, 50,000 ops.

16 amp resistive, 250VAC, 125°C, 50,000 ops.

### Initial Dielectric Strength

**Between Open Contacts:** 1,000Vrms.

**Between Coil and Contacts:** 4,000Vrms.

**Creepage/Clearance:** 8/8mm.

### Coil Data DC @ 20°C

**Nominal Coil Power:** 360mW.

Nominal Voltage VDC	DC Resistance in Ohms ±10%	Must Operate Voltage VDC	Drop-out Voltage VDC	Maximum Voltage VDC	Nominal Coil Current (mA)
6	100	3.8	0.6	16.9	60.0
12	400	7.5	1.2	33.8	30.0
24	1,600	14.9	2.4	67.7	15.0
48	6,400	30.0	4.8	135.3	7.5

### Operate Data

**Must Operate Voltage:** See Coil Data table.

**Operate Time:** 10 ms.

**Release Time:** 2 ms.

**Bounce Time (N/O contact / N/C contact) :** 1 ms / 2 ms.

**Switching Rate:** 3,600 ops./hr. max. at rated load.

### Environmental Data

**Temperature Range:**

**Operating:** -40°C to +125°C.

### Mechanical Data

**Termination:** Printed circuit terminals, plus quick connects for load.

**Enclosure (94 V-0 rated):** Flux-tight (RTII) plastic case.

**Weight:** 0.92 oz. (26 g) approximately.

### Contact Life

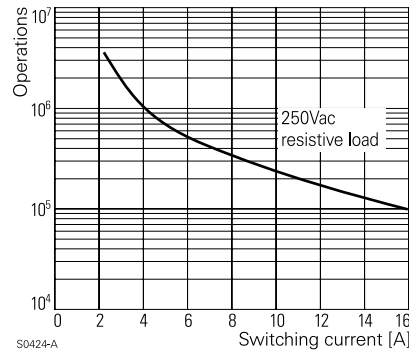

### Max. DC Load Breaking Capacity

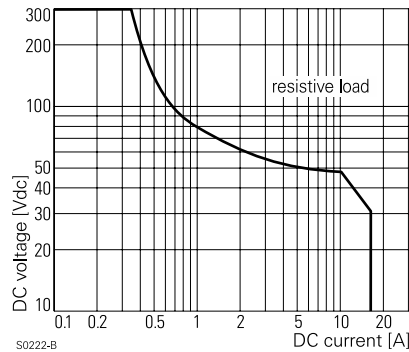

### Coil Operating Range

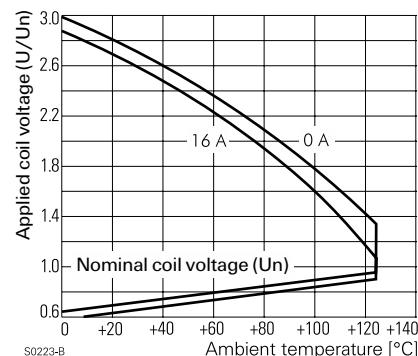

**Ordering Information**

Typical Part Number ▶

**V23077 -A 1 005 -A 4 03**

<b>1. Basic Series:</b> V23077 = IF 125°C miniature printed circuit board relay..
<b>2. Termination:</b> A = PC terminals for coil, .25" (6.35mm) quick connects for load.
<b>3. Version:</b> 1 = Standard.
<b>4. Coil Voltage:</b> 003 = 6VDC      005 = 12VDC      007 = 24VDC      009 = 48VDC
<b>5. Contact Type:</b> A = Single contact.
<b>6. Contact Material:</b> 4 = Silver-cadmium oxide.
<b>7. Contact Arrangement:</b> 02 = 1 Form A (SPST-NO).      03 = 1 Form B (SPST-NC).

**Our authorized distributors are more likely to stock the following items for immediate delivery.**

None at present.

**Outline Dimensions**

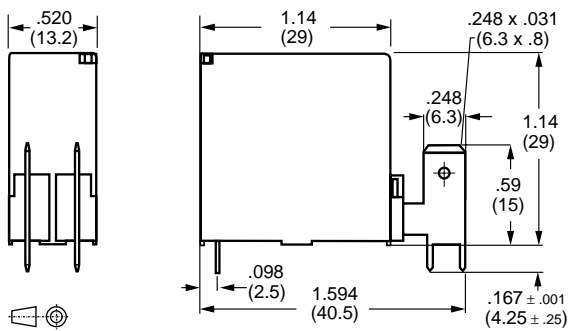

**Wiring Diagrams (Bottom Views)**

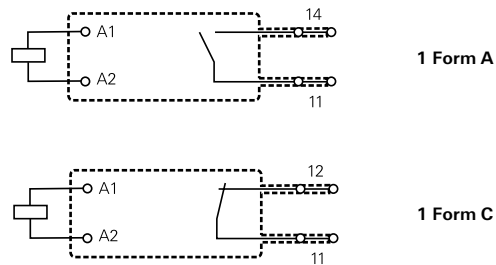

**PC Board Layout (Bottom View)**

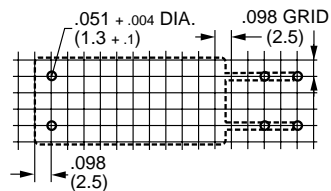



# 0410 series

## 16 Amp, Miniature Printed Circuit Board Relay

File E214025



NOTE: 0410 83 version is VDE only, not UL, CSA or SEMCO.

Users should thoroughly review the technical data before selecting a product part number. It is recommended that users also seek out the pertinent approvals files of the agencies/laboratories and review them to ensure the product meets the requirements for a given application.

### Features

- 1 Form A (SPST-NO), 1 Form B (SPST-NC) and 1 Form X (SPST-NO-DM).
- 16 amp rated current.
- Quick connect terminals for load.
- 410 63 types operate in ambient temperature up to 125°C.
- 4kV/8mm contact-to-coil, insulation to VDE 0631 and 0700.
- 410 83 version provides 3 mm contact gap.
- Flux-tight plastic case.

### Contact Data

#### Arrangements:

- 410 63:** 1 Form A (SPST-NO) and 1 Form B (SPST-NC), single contact.
- 410 83:** 1 Form X (SPST-NO-DM).

**Material:** 410 63: Silver-cadmium oxide.; 410 83: Silver-nickel.

**Expected Mechanical Life:** 10 million operations.

#### Ratings:

- Current:** 16A.
- Voltage:** 250VAC.
- Power (breaking):** 4,000 VA.
- Voltage (breaking):** 440VAC.
- Current (making, max. 4s at 10% duty cycle):**  
**410 63:** 25A.; **410 83:** 20A.

- 410 63 – 1 Form A Contacts**  
16 amp resistive, 250VAC, 125°C, 100,000 ops.  
12 amp resistive, 250VAC, 70°C, 450,000 ops.  
10 amp resistive, 400VAC, 125°C, 50,000 ops.  
12 amp  $\cos\phi = 0.6$ , 250VAC, 125°C, 50,000 ops.

- 410 63 – 1 Form B Contacts**  
16 amp resistive, 250VAC, 125°C, 150,000 ops.

- 410 83 – 1 Form X Contacts**  
16 amp resistive, 250VAC, 85°C, 30,000 ops.  
10 amp resistive, 250VAC, 85°C, 100,000 ops.  
10 amp resistive, 400VAC, 85°C, 10,000 ops.

### Initial Dielectric Strength

- Between Open Contacts:** 410 63: 1,000Vrms.; 410 83: 2,000Vrms.
- Between Coil and Contacts:** 4,000Vrms.
- Creepage/Clearance:** 8/8mm.

### Coil Data DC @ 20°C

**Nominal Coil Power:** 360mW.

Nominal Voltage VDC	DC Resistance in Ohms $\pm 10\%$	Must Operate Voltage VDC	Drop-out Voltage VDC	Maximum Voltage VDC	Nominal Coil Current (mA)
<b>410 63 models (1 Form A or 1 Form B)</b>					
6	100	3.8	0.6	16.9	60.0
12	400	7.5	1.2	33.8	30.0
24	1,600	14.9	2.4	67.7	15.0
48	6,400	30.0	4.8	135.3	7.5
<b>410 83 models (1 Form X with 3 mm contact gap)</b>					
6	100	3.6	0.45	16.9	60.0
12	400	7.3	0.9	33.8	30.0
24	1,600	14.6	1.8	67.7	15.0
48	6,400	29.2	3.6	135.3	7.5
60	10,000	36.5	4.5	135.3	6.0

### Operate Data

- Must Operate Voltage:** See Coil Data table.
- Operate Time (typical):** 410 63: 10ms.; 410 83: 14 ms.
- Release Time (typical):** 5 ms.
- Bounce Time (typical):** 3 ms.
- Switching Rate:** 6,000 ops./hr. max. at rated load.

### Environmental Data

#### Temperature Range:

**Operating:** 410 63: -20°C to +125°C; 410 83: -20°C to +85°C.

**Vibration:** (10 to 500 Hz.) 10g [410 83].

**Shock (functional):** 100g [410 83].

### Mechanical Data

**Termination:** Printed circuit terminals, plus quick connects for load.

**Enclosure (94 V-0 rated):** Flux-tight (RTII) plastic case.

**Weight:** 0.85 oz. (24 g) approximately.

### Contact Life

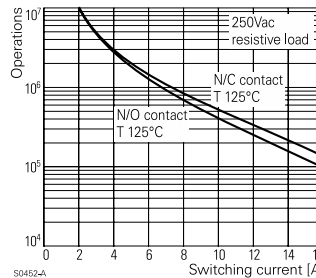

**410 63 Type**  
1 Form A or 1 Form C

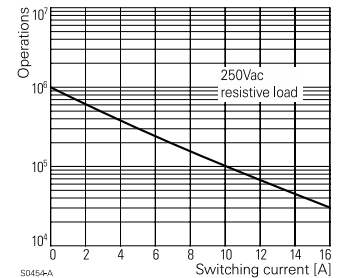

**410 83 Type**  
1 Form X, 3 mm Contact Gap

### Max. DC Load Breaking Capacity

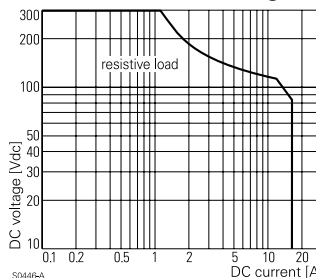

**410 63 Type**  
1 Form A or 1 Form C

### Coil Operating Range

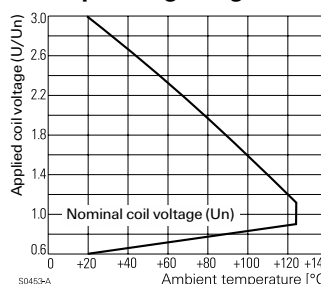

**410 63 Type**  
1 Form A or 1 Form C

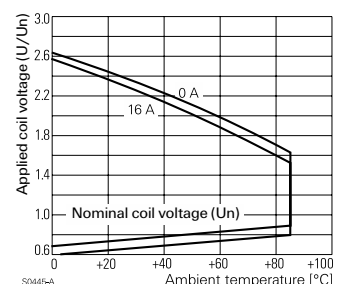

**410 83 Type**  
1 Form X, 3 mm Contact Gap

**Ordering Information**

<b>Typical Part Number ▶</b>	<b>0410</b>	<b>83</b>	<b>046</b>	<b>001</b>
<b>1. Basic Series:</b> 0410 = Miniature printed circuit board relay with quick connect terminals for load.				
<b>2. Version:</b> 63 = Model for ambient temperature up to 125°C. 83 = Model with 3 mm contact gap, for ambient temperature up to 85°C				
<b>3. Coil Voltage:</b> 054 = 6VDC      050 = 12VDC      046 = 24VDC      043 = 48VDC      042 = 60VDC (Note: 60VDC coil is not available with version 63)				
<b>4. Contact Arrangement:</b> 01 = 1 Form A (SPST-NO) on version 63; 1 Form X (SPST-NO-DM) on version 83. 02 = 1 Form B (SPST-NC), not available on version 83.				

**Our authorized distributors are more likely to stock the following items for immediate delivery.**

None at present.

**Outline Dimensions**

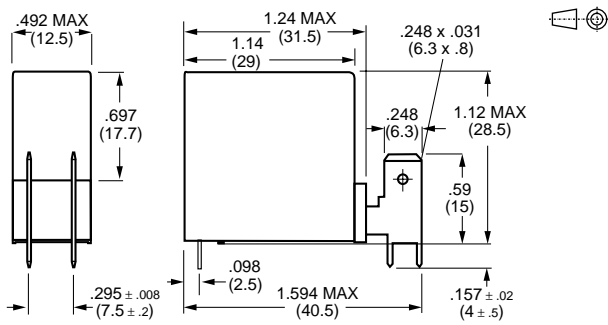

**Wiring Diagrams (Bottom Views)**



**410 63, 1 Form A**

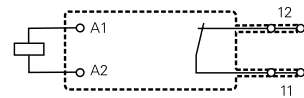

**410 63, 1 Form B**

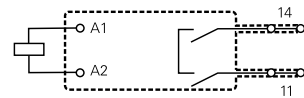

**410 83, 1 Form X**

**PC Board Layout (Bottom View)**

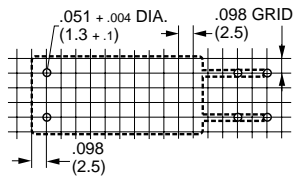



# PCG series

## 2 Pole Miniature Power PC Board Relay

Appliances, Audio Equipment, Office Machines

- UL File No. E82292
- CSA File No. LR48471
- SEMKO File No. 8744066
- SEV File No. 98110096

Users should thoroughly review the technical data before selecting a product part number. It is recommended that user also seek out the pertinent approvals files of the agencies/laboratories and review them to ensure the product meets the requirements for a given application.

### Features

- Meet UL Tungsten TV-5 rating.
- 2 Form A contact arrangements.
- Meet UL, CSA, SEMKO and SEV requirements.
- Meet 4,000V dielectric voltage between coil and contacts.
- Meet 10,000V surge voltage between coil and contacts (1.2 / 50µs).

### Contact Data @ 20°C

**Arrangements:** 2 Form A (DPST-NO).

**Material:** AgSnO.

**Max. Switching Rate:** 300 ops./min. (no load).  
30 ops./min. (rated load).

**Expected Mechanical Life:** 10 million operations (no load).

**Expected Electrical Life:** 100,000 operations (rated load).

**Minimum Load:** 100mA @ 5VDC.

**Initial Contact Resistance:** 100 milliohms @ 1A, 6VDC.

### Contact Ratings

**Ratings:** 5A @ 250VAC resistive, 100,000ops.  
8A @ 250VDC resistive, 50,000ops.  
TV-5 @ 120VAC Tungsten, 25,000ops.

**Max. Switched Voltage:** AC: 277V.  
DC: 30V.

**Max. Switched Current:** 10A.

**Max. Switched Power:** 1,250VA, 380W.

### Initial Dielectric Strength

**Between Open Contacts:** 1,000VAC 50/60 Hz. (1 minute).  
**Between Coil and Contacts:** 4,000VAC 50/60 Hz. (1 minute).  
**Surge Voltage Between Coil and Contacts:** 10,000V (1.2 / 50µs).  
**Surge Voltage Between Contact and other Pole:** 6,000V (1.2 / 50µs).

### Initial Insulation Resistance

**Between Mutually Insulated Elements:** 1,000M ohms min. @ 500VDCM.

### Coil Data

**Voltage:** 5 to 48VDC.  
**Nominal Power:** 540 mW  
**Coil Temperature Rise:** 50°C max., at rated coil voltage.  
**Max. Coil Power:** 130% of nominal.  
**Duty Cycle:** Continuous.

### Coil Data @ 20°C

Rated Coil Voltage (VDC)	Nominal Current (mA)	PCG		
		Coil Resistance (ohms) ± 10%	Must Operate Voltage (VDC)	Must Release Voltage (VDC)
5	106.4	47	4.00	0.25
6	88.0	68	4.80	0.30
9	58.0	155	7.20	0.45
12	44.4	270	9.60	0.60
24	21.8	1,100	19.20	1.20
48	11.0	4,400	38.40	2.40

### Operate Data

**Must Operate Voltage:** 80% of nominal voltage or less.  
**Must Release Voltage:** 5% of nominal voltage or more.  
**Operate Time:** 15 ms max.  
**Release Time:** 5 ms max.

### Environmental Data

**Temperature Range:**  
**Operating:** -30°C to +70°C  
**Vibration, Mechanical:** 10 to 55 Hz., 1.5mm double amplitude  
**Operational:** 10 to 55 Hz., 1.5mm double amplitude.  
**Shock, Mechanical:** 1,000m/s<sup>2</sup> (100G approximately).  
**Operational:** 100m/s<sup>2</sup> (10G approximately).  
**Operating Humidity:** 20 to 85% RH. (Non-condensing).

### Mechanical Data

**Termination:** Printed circuit terminals.  
**Enclosure (94V-0 Flammability Ratings):**  
**PCG-N:** Vented (Flux-tight) snap-on cover.  
**Weight:** 0.63 oz (18g) approximately.

**Ordering Information**

Typical Part Number ▶

**PCG -2 24 D 2 M N ,000**

**1. Basic Series:**

PCG = Miniature Power PC board relay.

**2. Termination:**

2 = 2 pole.

**3. Coil Voltage:**

05 = 5VDC      09 = 9VDC      24 = 24VDC  
06 = 6VDC      12 = 12VDC      48 = 48VDC

**4. Coil Input:**

D = Standard

**5. Contact Material:**

2 = AgSnO

**6. Contact Arrangement:**

M = 2 Form A, DPST-NO.

**7. Contact Rating:**

N = Vented (Flux-tight)\* snap-on cover.

**8. Suffix:**

,000 = Standard model      Other Suffix = Custom model

\* Not suitable for immersion cleaning processes.

**Our authorized distributors are more likely to maintain the following items in stock for immediate delivery.**

None at present.

**Outline Dimensions**

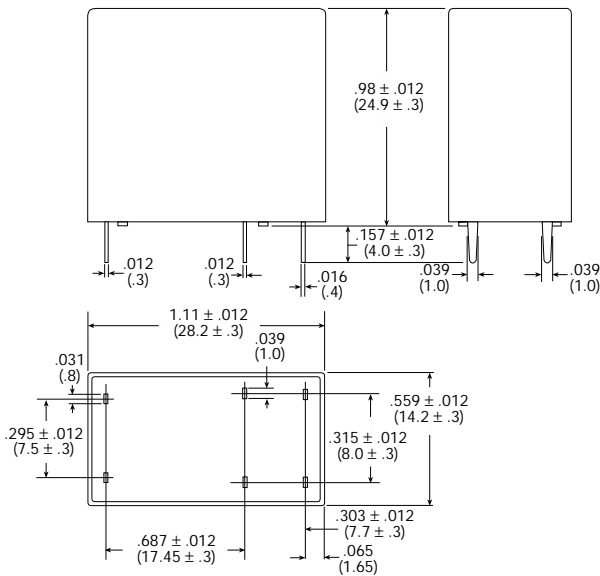

**Wiring Diagram (Bottom View)**

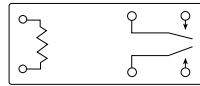

**PC Board Layout (Bottom View)**

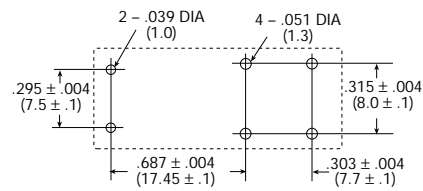

**Reference Data**

**Coil Temperature Rise**

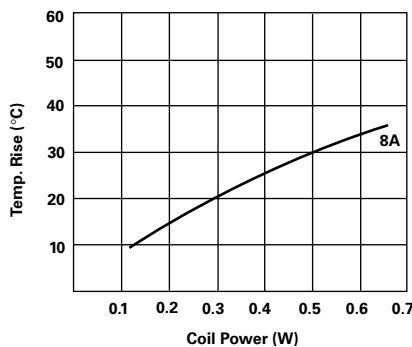

**Operate Time**

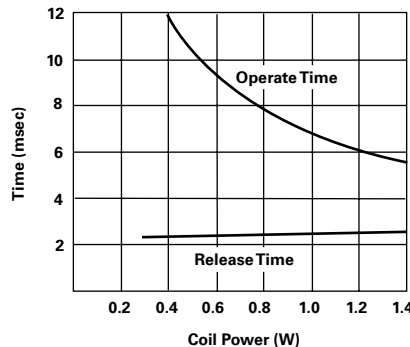

**Life Expectancy**

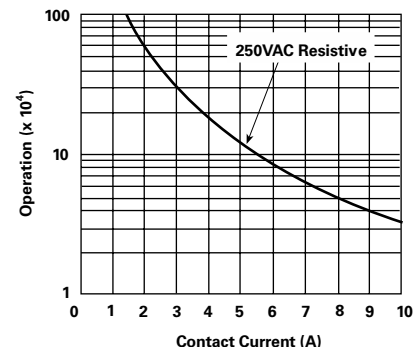



# 0430 series

## 10-16 Amp, 1 or 2 Pole PC Board or Panel Relay

File E214025  
UL

Users should thoroughly review the technical data before selecting a product part number. It is recommended that users also seek out the pertinent approvals files of the agencies/laboratories and review them to ensure the product meets the requirements for a given application.

### Features

- 1 Form A (SPST-NO) through 2 Form C (DPDT).
- 16 amp rated current (1 pole) or 10 amp (2 pole).
- Printed circuit or quick connect terminals.
- 4kV/8mm contact-to-coil.
- 3 mm contact gap version available.
- Optional magnetic blowout on 3mm contact gap version.
- PC board, bracket or panel mount.

### Contact Data

**Arrangements:** 1 Form A (SPST-NO), 1 Form B (SPST-NC), 1 Form C (SPDT), 2 Form A (DPST-NO), 2 Form B (DPST-NC), 2 Form C (DPDT).

**Material:** Silver-cadmium oxide or silver-copper 3.

**Expected Mechanical Life:** 250,000 operations.

#### Ratings:

**Current:** One pole: 16A; Two pole: 10A.

**Voltage:** 250VAC.

**Power (breaking):** One pole: 4,000 VA; Two pole: 2,500VA.

**Voltage (breaking):** 400VAC.

**Current (making, max. 4s at 10% duty cycle):**

One pole: 25A; Two pole: 15A.

**Load/Life – One Pole – Model with Standard Contact Gap**

16 amp resistive, 250VAC, 250,000 ops.

**Load/Life – One Pole – Model with 3mm Contact Gap**

16 amp resistive, 250VAC, 70°C, 150,000 ops.

10 amp resistive, 250VAC, 105°C, 150,000 ops.

**Load/Life – Two Pole**

10 amp resistive, 250VAC, 250,000 ops.

### Operate Data

**Must Operate Voltage:** See Coil Data table.

**Operate Time (typical):** Standard Contact Gap: 18 ms.  
3mm Contact Gap: 15 ms.

**Release Time (typical):** Standard Contact Gap: 3 ms.  
3mm Contact Gap: 8 ms.

**Bounce Time (typical):** Standard Contact Gap: 3 ms.  
3mm Contact Gap: 4 ms.

**Switching Rate:** 9,000 ops./hr. max. at rated load.

### Environmental Data

**Temperature Range:**

Operating: 410 63: -20°C to +70°C.

**Shock (destructive):** 100g.

### Mechanical Data

**Termination:** Printed circuit or quick connect terminals.

**Enclosure:** Plastic dust cover.

**Weight:** 1.13 oz. (32 g) approximately.

### Initial Dielectric Strength

**Between Open Contacts:** Standard Contact Gap: 1,000Vrms

3mm Contact Gap: 2,000Vrms.

**Between Coil and Contacts:** 4,000Vrms.

**Creepage/Clearance:** 8/8mm.

### Coil Data DC @ 20°C

**Nominal Coil Power:** DC Coil : 1W.; AC Coil: 1.8VA

Nominal Voltage VDC	DC Resistance in Ohms ±10%	Must Operate Voltage VDC	Drop-out Voltage VDC	Maximum Voltage VDC	Nominal Coil Current (mA)
<b>DC Coils</b>					
12	145	7.8	0.6	15.6	83.0
24	580	15.6	1.2	31.2	41.0
48	2,200	31.2	2.4	62.4	22.0
110	13,000	71.5	5.5	143.0	9.0
<b>AC Coils – Models with Standard Contact Gap</b>					
24	200	18.0	3.6	27.0	75.0
60	1,250	45.0	9.0	69.0	30.0
110	4,500	83.0	16.0	127.0	16.0
230	17,500	170.0	35.0	253.0	10.0
<b>AC Coils – Models with 3mm Contact Gap</b>					
24	145	18.0	3.6	27.0	75.0
60	950	45.0	9.0	69.0	30.0
110	3,100	83.0	16.0	127.0	16.0
230	11,400	170.0	35.0	253.0	9.0

### Contact Life

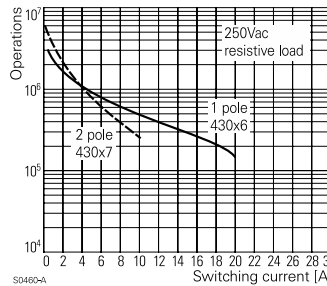

Models with Std. Contact Gap

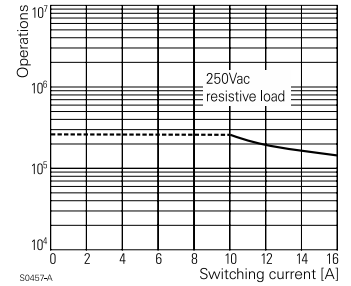

Models with 3mm Contact Gap

### Max. DC Load Breaking Capacity

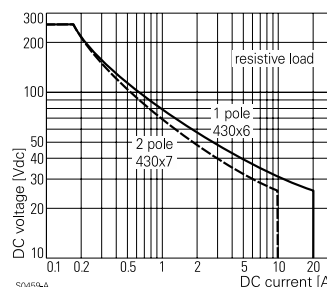

Models with Std. Contact Gap

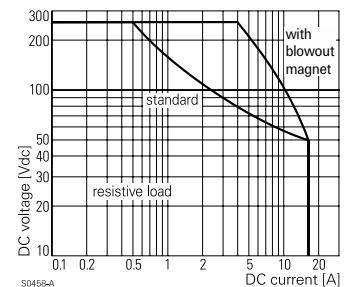

Models with 3mm Contact Gap

**Ordering Information**

<b>Typical Part Number ▶</b>		<b>0430</b>	<b>1</b>	<b>6</b>	<b>10</b>	<b>1</b>	<b>100</b>
<b>1. Basic Series:</b> 0430 = Miniature printed circuit board or panel mount relay.							
<b>2. Mounting:</b> 0 = PC board      1 = Mounting brackets      2 = Snap mounting      5 = DIN rail mounting							
<b>3. Version:</b> 4 = 1 pole, 3mm gap.      5 = 1 pole, 3mm gap, magnetic blowout.      6 = 1 pole, Std. gap.      7 = 2 pole, Std. gap.							
<b>4. Coil Voltage:</b> DC Coils for all Types:      09 = 12VDC      10 = 24VDC      11 = 48VDC      13 = 110VDC AC Coils for Std. Gap Types:      03 = 24VAC      05 = 60VAC      06 = 110VAC      07 = 230VAC AC Coils for 3 mm Gap Types:      23 = 24VAC      25 = 60VAC      26 = 110VAC      27 = 230VAC							
<b>5. Contact Material:</b> 0 = Silver-copper 3      1 = Silver-cadmium oxide.							
<b>6. Contact Arrangement:</b> 100 = 1 Form A (SPST-NO)      200 = 1 Form B (SPST-NC)      300 = 1 Form C (SPDT). 400 = 2 Form A (DPST-NO)      500 = 2 Form B (DPST-NC)      600 = 2 Form C (DPDT). Note: 2 pole forms not available with 3mm contact gap.							

**Our authorized distributors are more likely to stock the following items for immediate delivery.**

None at present.

**Outline Dimensions**

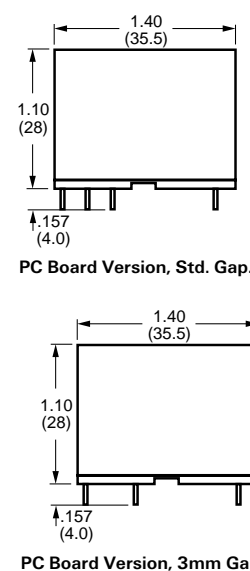
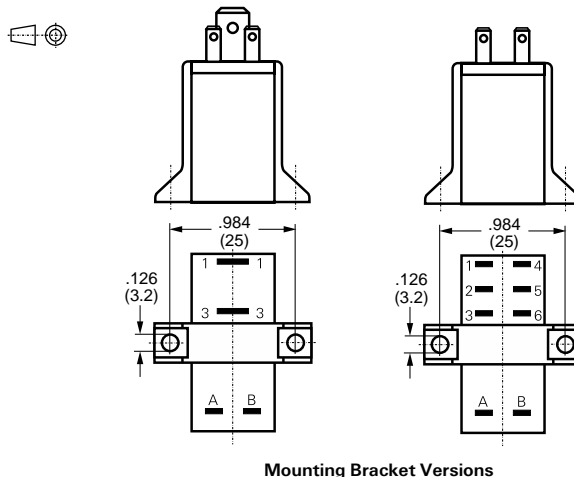
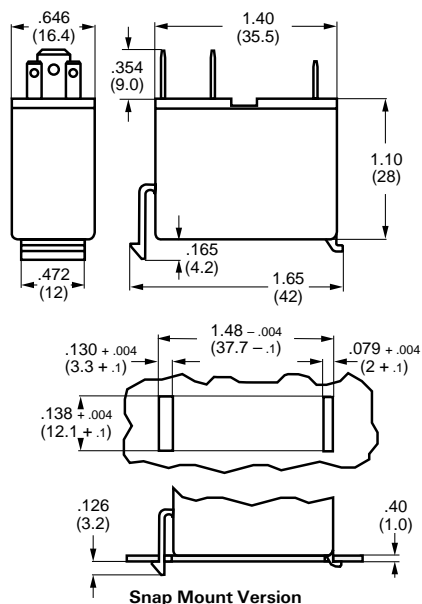

**PC Board Layouts (Bottom Views)**

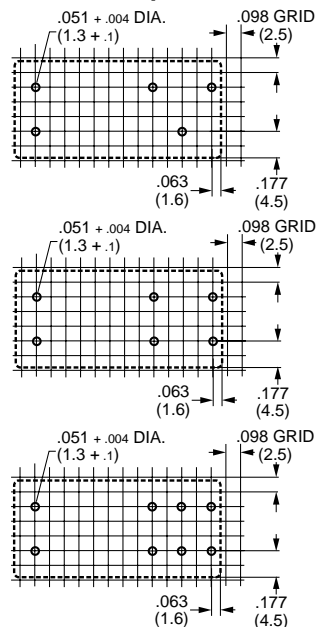

1 Form A, Standard Contact Gap

1 Form A, 3mm Contact Gap

2 Form A, Standard Contact Gap

**Wiring Diagrams (Bottom Views)**

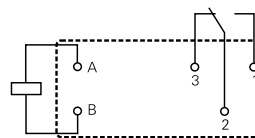

1 Form A, Standard Contact Gap

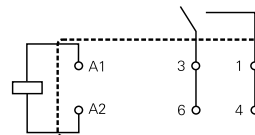

1 Form A, 3mm Contact Gap

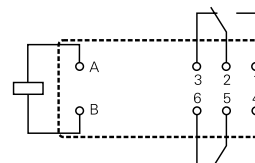

2 Form A, Standard Contact Gap



# 600 series

## 15 Amp Sensitive PC Board Relay

File E39006 and E42149  
File LR48569

Users should thoroughly review the technical data before selecting a product part number. It is recommended that users also seek out the pertinent approvals files of the agencies/laboratories and review them to ensure the product meets the requirements for a given application.

### Features

- Low power sensitive coil.
- 1 Form A, 1 Form B and 1 Form C contact arrangements.
- Various contact materials and types for ratings to 15 amps.
- Coil assembly rated 130°C, 94V-O.
- Applications include sensor and timer controls, emergency lighting, instrumentation, alarm systems, smoke and fire detectors, business equipment and vending machines.

### Contact Data

**Arrangements:** 1 Form A (SPST-NO), 1 Form B (SPST-NC) and 1 Form C (SPDT).

**Material and Type:** Gold-silver crossbar, silver-cadmium crossbar, palladium crossbar, gold-flashed silver cadmium, silver sadmium oxide, find silver, gold-flashed coin silver.

**Expected Mechanical Life:** 10 million operations, minimum.

**Expected Electrical Life:** 100,000 operations, minimum, at rated load.

### UL/CSA Ratings @ 25°C

Code	Contact Material	Rating
B	Au Flashed AgCd	75VA@24VAC Pilot Duty§ 1A@120VAC General Purpose 1.5A@50VDC Resistive 600W@277VAC Gen'l. Purpose SPST-NO Only 240W@277VAC Gen'l. Purpose SPST-NC Only 480VA@277VAC Pilot Duty SPDT Only 480VA@Ballast SPDT Only 1/10 HP@120VAC
G	Au Ag	3A@28VDC Resistive 125VA@120VAC Pilot Duty§ 1/8 HP@120/240 VAC
H	AgCdO	15A@150VAC Inductive 0.4 PF NO Only 10A@277VAC Resistive 15A@28VDC Resistive TV5@NO Contacts TV2@NC Contacts 600W@277VAC Tungsten SPDT-NO Only 240W@277VAC Tungsten SPDT-NC Only 480VA@277VAC Pilot Duty SPDT Only § 480VA@277VAC Ballast SPDT Only 1/3 HP@120/240VAC NO 1/6 HP@120/240VAC NC
K	Au Flashed Coin Ag	5A@240VAC Resistive 5A@28VDC 125VA@240VAC Pilot Duty § 125VA@125VAC Pilot Duty §
R	Fine Ag	15A@150VAC Resistive 15A@28VDC Resistive 10A@277VAC Resistive 480VA@240VAC Pilot Duty TV2@NC Contacts TV4@NO Contacts 480W@120VAC Tungsten NO 240W@120VAC Tungsten NC
S	Ag Cd	3A@240VAC Resistive 3A@28VDC Resistive
V	Palladium	2A@28VDC Resistive

§ Only when Code Y Electrical Spacing is specified.

Dimensions are shown for reference purposes only.

Dimensions are in inches over (millimeters) unless otherwise specified.

### Initial Dielectric Strength

**Between Open Contacts:** 500VAC, 60 Hz., 2 seconds.

**Between Coil and Contacts:** 1,000VAC, 60 Hz., 2 seconds.

### Coil Data @ 25°C

**Rated Voltage:** 3 to 48VDC.

**Maximum Voltage @ 85°C:** 120% of Rated Voltage.

**Nominal Power @ 25°C:** 110mW for 3A and 5A rated models;  
240mW for 15A rated models.

**Maximum Power @ 25°C:** 1W.

**Duty Cycle:** Continuous.

**Initial Insulation Resistance:** 10,000 megohms, min., at 25°C, 500VDC and 50% rel. humidity.

### Coil Data @ 25°C

Nominal Voltage VDC	DC Resistance in Ohms ±10%		Must Operate Voltage VDC	Must Release Voltage VDC
	3 A & 5A Types	15A Types		
003	82	38	2.25	0.3
006	327	150	4.5	0.6
009	736	338	6.75	0.9
012	1,309	600	9.0	1.2
018	2,945	1,350	13.5	1.8
024	5,236	2,400	18.0	2.4
028	7,127	3,267	21.0	2.8
048	20,945	9,600	36.0	4.8

### Operate Data @ 25°C

**Must Operate Voltage:** 75% of nominal.

**Must Release Voltage:** 10% of nominal.

**Operate Time:** 10 ms, typ.

**Release Time:** 10 ms, typ.

### Environmental Data

**Temperature Range:**

**Storage:** -55°C to +85°C.

**Operating:** -55°C to +85°C.

### Mechanical Data

**Termination:** Printed circuit terminals.

**Enclosures:** Unsealed dust cover or sealed plastic case.

**Weight:** 1.6 oz. (45g) approximately.

Specifications and availability subject to change.

www.tycoelectronics.com  
Technical support:  
Refer to inside back cover.

**Ordering Information**

<b>Typical Part Number ▶</b>	<b>60</b>	<b>3</b>	<b>- 24</b>	<b>V</b>	<b>Y</b>	<b>Q</b>
<p><b>1. Basic Series Type:</b>                  60 = Miniature, PC board relay rated 3A or 5A (Contact Material Code G, S, V or B only)                  61 = Miniature, PC board relay rated 15A (Contact Material Code H or R only)                  65 = Miniature, PC board relay rated 5A (Contact Material Code K only)</p>						
<p><b>2. Contact Arrangement:</b>                  1 = 1 Form A (SPST-NO)      2 = 1 Form B (SPST-NC)      3 = 1 Form C (SPDT)</p>						
<p><b>3. Coil Voltage:</b>                  003 = 3VDC      009 = 9VDC      018 = 18VDC      028 = 28VDC                  006 = 6VDC      012 = 12VDC      024 = 24VDC      048 = 48VDC</p>						
<p><b>4. Contact Material:</b>                  G = Au Ag crossbar, rated 3A (Only available with Basic Series Type 60).                  S = Au Cd crossbar, rated 3A (Only available with Basic Series Type 60).                  V = Pd crossbar, rated 3A (Only available with Basic Series Type 60).                  B = Au-flashed AgCd crossbar, rated 5A (Only available with Basic Series Type 60).                  H = AgCdO, rated 15A (Only available with Basic Series Type 61).                  R = Fine Ag, rated 15A (Only available with Basic Series Type 61).                  K = Au-flashed coin Ag, rated 5A (Only available with Basic Series Type 65).</p>						
<p><b>5. Electrical Spacing:</b>                  Leave Blank = 0.125 in (3.175 mm) Clearance and 0.125 in (3.175 mm) Creepage                  Y = 0.125 in (3.175 mm) Clearance and 0.250 in (6.35 mm) Creepage</p>						
<p><b>6. Enclosure Type</b>                  Leave Blank = Unsealed dust cover      Q = Sealed cover</p>						

**Our authorized distributors are more likely to stock the following items for immediate delivery.**

None at present.

**Outline Dimensions**

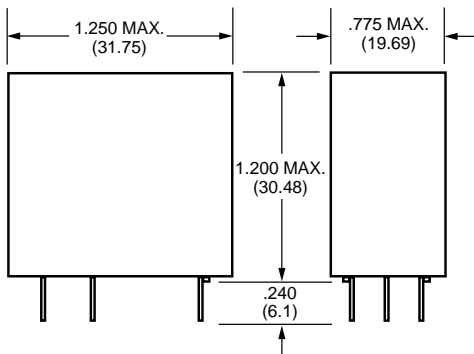

**PC Board Layout (Bottom View)**

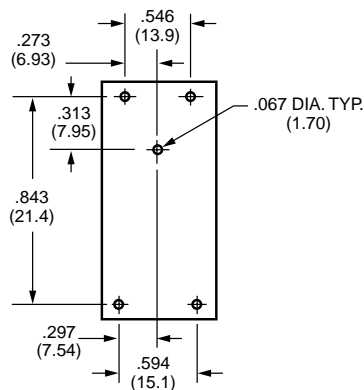

**Note:** On single throw models, only necessary terminals are present.

**Wiring Diagrams (Bottom Views)**

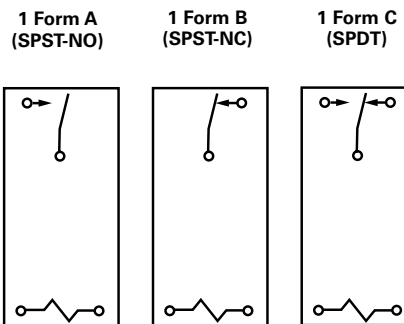

**Note:** On single throw models, only necessary terminals are present.